This is a reproduction of a library book that was digitized by Google as part of an ongoing effort to preserve the information in books and make it universally accessible.

Google™ books

<https://books.google.com>







THE
TELEGRAPH MANUAL:

A COMPLETE

HISTORY AND DESCRIPTION

OF THE

Semaphoric, Electric and Magnetic Telegraphs

OF

EUROPE, ASIA, AFRICA, AND AMERICA,

ANCIENT AND MODERN.

WITH SIX HUNDRED AND TWENTY-FIVE ILLUSTRATIONS.

Et non "eripuit calo fulmen,"
Fulguri mentem fudit, et orbem lumine cinxit.—PITILE.

BY TAL. P. SHAFFNER,
OF KENTUCKY.

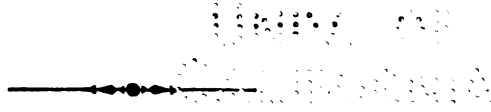

NEW YORK:
D. VAN NOSTRAND No. 192 BROADWAY.
1867.

Entered, according to Act of Congress, in the year 1859,

By TALLAFERRO P. SHAFNER,

In the Clerk's Office of the District Court of the United States, for the
District of Kentucky.

70 v. 100
1859.1.10

P R E F A C E.

IN the preparation of this volume, the author has not advanced theories, other than those which are founded upon demonstrated philosophy. It is to be understood, however, that many of the views expressed concerning questions in the sciences may, from time to time, be modified by new developments. In every instance, the opinions given are based upon the known sciences as manifested through the medium of the arts, and more particularly the electric telegraph.

I have reviewed the early semaphore telegraphs, and explained their respective modes of operation. These visual systems have, however, ceased to be employed by civilized nations, except for the marine service.

As preliminary to the consideration of the electric telegraph, I have introduced a few chapters explanatory of the sciences immediately blended in that art; such, for example, as static and voltaic electricities, magnetism, and electro-magnetism. These questions of philosophy the telegrapher should most carefully study. The data given are from the most reliable authorities.

In the collection of materials for this work I have spared neither labor nor expense. For nearly fifteen years I have made the subject-matter of this volume my most careful study. For the greater part of that time, practical telegraphing has been my sole vocation. I have instituted thousands of experiments, and have travelled over most of the civilized world "in search of light" upon this, the most important of all arts. The information herein imparted has cost me years of toil and

a heavy expenditure of money. Still, I cannot regret my devotion, either past or present, to the cause. In its study I have found new truths, serving to increase my admiration of that mysterious Providence who knoweth all things.

I have not written this book for gain. It has been to me a work of love. For several years I have been urged by friends to prepare a work on practical telegraphing, and I have in the present volume complied with that wish. I have not confined the work to the telegraph of any particular locality, but, on the contrary, I have grouped together the various systems of both hemispheres. Nearly every combination herein described I have witnessed in operation and most carefully studied. I may have failed to comprehend the full merits of each, and my descriptions of them, respectively, may be imperfect, though I have tried to make them clear and concise.

I have not attempted to arrange the various systems with regard to priority of invention, nor as to their relative efficiency. I have given dates wherever it was possible, and have refrained from exhibiting any preferences. I indulge the hope that the many inventors who have distinguished the age by the production of their respective contrivances, will not accuse me of an undue partiality. I have tried to be fair in the consideration of the merits of each discovery and each invention. If I have failed in accomplishing this desideratum, the fault lies, not with the heart, but with the judgment.

Notwithstanding that this volume has been greatly extended, I have been compelled to omit several important chapters; such, for example, as the organizations for generating magneto-electricity, the aurora-borealis, the fire-alarm and railway telegraphs, repeating apparatuses, &c. These will be duly considered in some subsequent edition, together with such emendations and additions to the present work as shall be found necessary.

To M. Blavier and his publishers in Paris, to the publishers of Noad's "Electricity," the "Illustrated London News," and others who have given me full permission to copy from their respective works, I am especially indebted. On the other

hand, some authors and publishers have refused me that permission; and although I could have copied whatever I might have wanted from any foreign work without legal liability, yet I have not done so, knowingly, in a single case where the privilege was refused me.

I cannot conclude this review of my labors, without expressing my most profound thanks to my very able and accomplished friend George Jaques, of Worcester, Massachusetts, for his aid in translating from the various languages of the Old World, and in searching for new light and authorities. For the services thus rendered, I cannot but feel the highest appreciation, and a sincere desire that his future life may be blessed with that which will enable him to fill the measure of his creation, and that his fireside may be surrounded with those jewels which are more brilliant than the pearls and gems that sparkle from and adorn the imperial crown.

In preparing this work I have made copious extracts from various publications, among which may be particularly mentioned, Noad's Manual of Electricity, Highton's History of the Electric Telegraph, Dr. O'Shaughnessy's Electric Telegraph, Bakewell's Manual of Electricity, Moigno's *Traité de Télégraphie Electrique*, Blavier's *Cours Théorique et Pratique de Télégraphie Electrique*, Davis's Manual of Magnetism, Walker's Electric Telegraph Manipulation, Shaffner's Telegraph Companion, Dr. Schellen's *Electro-magnetische Telegraph*, Vail's Electric Telegraph, Dr. Trumbull's Electric Telegraph, Shaffner's Telegraph Tariff Scale, Smithsonian Reports, American and European Patent Reports, &c., &c. I have not, in all cases, particularly marked the extracts taken, because, in many of them, I have blended new matter, and, to a greater or less extent, expressed their ideas in different language. In justice, however, to the respective authorities I make this general acknowledgment.

To the respective governments of Europe I feel deeply grateful, especially to the French, Belgian, Prussian, Danish, Swedish, Norwegian, and Russian. For the facilities given, and the vast amount of material placed at my command on

my visits to them respectively, and for the documents from time to time transmitted, I have been placed under lasting obligations. To M. Chauvin, director-general of the Royal Prussian Telegraphs, I have to express my sincere thanks for recent valuable documents; though their reception was too late for the present edition, they will serve a good end in the future.

It is my purpose to continue this work by subsequent editions, and embrace the improvements continually making in the art of telegraphing. Should the reader find any errors in this volume of either omission or commission, he will serve a good end by informing me of the fact. It is very desirable to promulgate truths well sustained by practical demonstrations; and if there be anything in this volume otherwise, it is for the weal of the enterprise that the false doctrines should be at the earliest moment suppressed.

In conclusion, I would add, that I have been compelled to write this volume piecemeal, on the steamboat, on the railway, at various hotels, and at places thousands of miles apart. All this I have had to do within the past six months. And while, in obedience to other duties, it has not been possible for me to give that personal attention to its passage through the press I should have wished, the novel and technical character of its contents rendered more difficult the labors of the correctors of the press, to whose care it was necessarily left.

With these explanations, I submit the "Telegraph Manual" to the generous and impartial consideration of the telegraphers throughout the world.

TAL. P. SHAFFNER.

NEW-YORK, *July*, 1859.

CONTENTS.

CHAPTER I.

THE TELEGRAPH.

The meaning of the term Telegraph—Divine Telegraph—Telegraphs mentioned in the Classics and Ancient History—The Telegraph invented by Polybius—Agamemnon's Telegraph, B. C. 1084—North American Aboriginal Telegraph—The American Revolutionary Army SignalsPAGE 17

CHAPTER II.

THE SEMAPHORE TELEGRAPH.

Origin of the Semaphore Telegraph—Its Adoption by the French Government—Its Extension over Europe—A German Telegraph Station—Russian Telegraph..... 27

CHAPTER III.

THE CHAPPE TELEGRAPH, ETC.

Description of the Chappé Telegraph—Organization of the Signal Alphabet—Process of Manipulation—Its Celerity in Sending Dispatches..... 32

CHAPTER IV.

OTHER SEMAPHORE TELEGRAPHS.

The Prussian Semaphore Telegraph—The English Semaphore—The Gonon, Chappé, Guyot, and Treutler's Improvements on the Chappé Telegraph..... 46

CHAPTER V.

STATIO ELECTRICITY.

Static Electricity Explained—Conductors and Non-Conductors—Vitreous and Resinous Electricity—Discovery of the Leyden Jar—Franklin's Electrical Theories—Coulomb's Theories of Electro-Statics—Franklin's Reasons for believing that Lightning and Electricity were Identical—Identity of Lightning and Electricity Demonstrated—The Franklin Kite Experiment—Distribution of Electricity—Phenomena of Resistance to Induction—Phenomena of Attraction and Repulsion—Igniting Gas with the Finger—The Leyden Jar Experiments 51

CHAPTER VI.

VOLTAIC ELECTRICITY.

Electrical Phenomena Discovered by Galvani—Origin of the Voltaic Pile—Science of the Voltaic Battery—Ohm's Mathematical Formulæ—Chemical and Electrical Action of the Battery—The Daniell, the Smee, the Bunson, the Grove, and the Chester Voltaic Batteries—Comparative Intensity and Quantity of the Grove, Daniell, and Smee Batteries	77
--	----

CHAPTER VII.

MAGNETISM.

Native Magnetism of the Load-Stone—Attractive and Repulsive Forces of Permanent Magnets—Component parts of the Magnet—Induced Magnetism.....	105
--	-----

CHAPTER VIII.

ELECTRO-MAGNETISM.

Discovery of Electro-Magnetism by Ersted—Discoveries of Schweigger, Arago, and Ampère—Discoveries of Sturgeon and Henry—Recapitulation of the Discoveries on Electro-Magnetism—English Telegraph Electrometers—Magnetometers—The De La Rive Ring and other Experiments	114
--	-----

CHAPTER IX.

EARLY ELECTRIC TELEGRAPHS.

Suggestions of Science—The Telegraph of Lomond—Reizen's and Dr. Salva's Electric Spark Telegraph—Baron Schilling's, Gauss and Weber's, and Alexander's Telegraphs	132
---	-----

CHAPTER X.

SOEMMERING'S ELECTRO-CHEMICAL TELEGRAPH.

Soemmering's Electric Telegraph of 1809—The Apparatus and Manipulation Described—Signal Keys for opening and closing the Circuits.....	142
--	-----

CHAPTER XI.

RONALD'S ELECTRIC TELEGRAPH.

Invention of Ronald's Electric Telegraph—Experiments and Description of the Apparatus—Description of an Electrograph	147
--	-----

CHAPTER XII.

STEINHEIL'S ELECTRIC TELEGRAPH.

Experiments and Discovery of the Earth Circuit—The Electric Telegraph as Invented—The Electric Conducting Wires—Conductibility of the Earth Circuit—Apparatus for Generating the Electric Current—The Indicating Apparatus—Construction of the Apparatus—Application of the Apparatus to Telegraphing—The Alphabet and Numerals—The Discovery and Invention of Steinheil	157
--	-----

CHAPTER XIII.

HISTORY OF THE ENGLISH ELECTRIC TELEGRAPH.

William Fothergill Cooke and the Telegraph—Möncke's Electrometer Experiments—The English Electric Telegraph invented—Invention of the Alarum—The Mechanical Telegraph—The Escapement Apparatus—Mr. Cooke's Efforts to put his Telegraph in Operation—The Second Mechanical Telegraph—Wheatstone's Permutating Key-Board—Messrs. Cooke and Wheatstone become associated—The Secondary Circuit invented—Mr. Cooke improves his Original Telegraph—All the Improvements combined—Description of the Apparatuses—Improvements patented in 1838—Wheatstone's Mechanical Telegraph—Further Improvements by Mr. Cooke. 179

CHAPTER XIV.

THE ENGLISH ELECTRIC TELEGRAPH.

English Telegraph, and Description of its Electrometer—The Single-Needle Apparatus—Formation of the Alphabet—Single-Needle Instrument and Voltaic Circuit—The Double-Needle Instrument, Alphabet, and Manipulation—The Alarum Apparatus—Combining and Arranging of Circuits. 216

CHAPTER XV.

INTERIOR OF THE ENGLISH TELEGRAPH STATIONS.

Interior Arrangements of a Station—Rate of Signalling—The Strand Telegraph Station—The Public Receiving Department—Blank Forms of the English Telegraphs . . 233

CHAPTER XVI.

DAVY'S ELECTRO-CHEMICAL TELEGRAPH.

Nature of the Invention described—The Transmitting Apparatus—The Receiver—The Instruments combined—The Manipulation—The Signal Alphabet 255

CHAPTER XVII.

BAIN'S PRINTING TELEGRAPH.

Description of the Printing Telegraph Apparatus. 269

CHAPTER XVIII.

THE BRETT PRINTING TELEGRAPH.

Brett's Printing Telegraph—Description of the Composing Apparatus—The Printing Apparatus and Manipulation—The Compositor or Commutator described—Mr. Brett's Last Improvement. 273

CHAPTER XIX.

THE MAGNETO-ELECTRIC TELEGRAPH.

Application of Magneto-Electricity to Telegraphing—Its Advantages—Description of Henley's Apparatus—The Bright's Apparatus—Its Comparative Celerity 286

CHAPTER XX.

HIGHTON'S ELECTRIC TELEGRAPHS.

High Tension Electric Telegraph—Gold Leaf Instruments—Single and Double Pointer Needle Apparatus—Revolving Pointer—Improvements in Batteries and Insulation 295

CHAPTER XXI.

BAKEWELL'S ELECTRIC COPYING TELEGRAPH.

Manipulation of the Electric Copying Telegraph of F. C. Bakewell of England—The Apparatus Described—Secrecy of Correspondence, its Advantages and Disadvantages..... 304

CHAPTER XXII.

NOTT'S ELECTRIC TELEGRAPH.

Description of the Apparatus 310

CHAPTER XXIII.

SEIMENS AND HALSKIE'S GERMANIC TELEGRAPH.

Description of the Telegraph Apparatus—The Alarm Bell—Electric Circuits and Manipulation—The Transmitter and its Application..... 313

CHAPTER XXIV.

FRENCH ELECTRIC TELEGRAPH.

The Nature and Origin of the System—The Receiving Apparatus—The Manipulating Apparatus—The Process of Sending Signals—The Formation of the Alphabet .. 325

CHAPTER XXV.

THE FRENCH RAILWAY ELECTRIC TELEGRAPH.

Principles of the French Railway Telegraph—Description of the Receiving Instrument—The Manipulating Apparatus—Process of Manipulation between Stations—Portable Apparatus for Railway Service—Breguet's Improvement..... 334

CHAPTER XXVI.

ELECTRIC TELEGRAPH BELL APPARATUS.

The French Telegraph Bell Instruments—Vibratory Bell Apparatuses—Use of Bells in Telegraph Offices 346

CHAPTER XXVII.

THE ELECTRO-CHEMICAL TELEGRAPH.

Bain's Electro-Chemical Telegraph—Apparatus and Manipulation—Smith and Bain's Patented Invention—Bain's Description and Claims—Morse's Electro-Chemical Telegraph—Westbrook and Rogers' Electro-Chemical Telegraph 354

CHAPTER XXVIII.

FROMENT'S ALPHABETICAL AND WRITING TELEGRAPHS.

Alphabetical Apparatus and Manipulation—The Writing Apparatus 373

CHAPTER XXIX.

VAIL'S PRINTING TELEGRAPH.

Description of the Telegraph Apparatus—Manipulation and Celerity of Communicating—Arrangement of the Alphabet 382

CHAPTER XXX.

THE HOUSE PRINTING TELEGRAPH.

Early History of the House Telegraph—The Composing and Printing Apparatuses—The Axial Magnet—The Air Valve and Piston—The Manipulation—The Patented Claim 391

CHAPTER XXXI.

HISTORY OF THE AMERICAN ELECTRO-MAGNETIC TELEGRAPH.

Invention of the Telegraph—The First Model of the Apparatus—Specimen of the Telegraph Writing—The Combined Circuits Invented—Favorable Report of the Committee on Commerce in Congress—Construction of the Experimental Line—Invention of the Local Circuit—Improvements of the Apparatus—Administration of the Patents, by Hon. F. O. J. Smith, and Hon. Amos Kendall—Extension of Lines in America . . . 402

CHAPTER XXXII.

THE MORSE TELEGRAPH APPARATUSES.

The Early Telegraph Instruments—Modern Lever Key—The Early Circuit Changer—Modern Circuit Closers—Nottebohn's Circuit Changer—Binding Connections—The Electro-Magnet of 1844—The Modern Relay Magnet—The Receiving Register—The Sounder 422

CHAPTER XXXIII.

INTERIOR OF AN AMERICAN TELEGRAPH STATION.

Receiving Department of a Telegraph Station—The Operating or Manipulating Department—Receiving Dispatches by Sound—Incidents of the Station—Execution of an Indian Respited by Telegraph 458

CHAPTER XXXIV.

THE MORSE TELEGRAPH ALPHABET.

Composition of the American Morse Alphabet—The Alphabet, Numerals, and Punctuation—The Austro-Germanic Alphabet of 1854—European Morse Alphabet of 1859 469

CHAPTER XXXV.

TELEGRAPH ELECTRIC CIRCUITS.

Electric Circuits on European Lines—Circuit of the Main Line described—Adjustment of the Line Batteries—Early Experimental Circuits—The Stager Compound Circuits—Combining of Electric Circuits..... 480

CHAPTER XXXVI.

ELECTRIC CURRENTS.

Electric Currents Explained—Electric Circuits—Quantity and Intensity Currents—Phenomena of the Return Current—Retardation of the Current Illustrated—Estimated Velocity of the Current—Working of the Mediterranean Telegraphs—Scale of the Velocity of the Current on Subaqueous Conductors..... 496

CHAPTER XXXVII.

ELECTRIC TELEGRAPH CONDUCTORS.

Composition of Telegraph Circuits—Conductibility of Metals and Fluids—Conducting Power of different sizes of Copper Wire—Conducting Power of Telegraph Wires—Advantage of Zinc-Coated Wires—Conductors composing a Voltaic Circuit—Strength of Telegraph Wires—Scale and Weight of Telegraph Wires 513

CHAPTER XXXVIII.

GUTTA-PERCHA INSULATION.

Application of Gutta-Percha as an Insulation—Discovery of Gutta-Percha, its Nature, Qualities, and Chemical Properties 524

CHAPTER XXXIX.

TELEGRAPH INSULATION.

English Telegraph Insulators—The American, the French, the Sardinian, the Bavarian, the Holland, the Baden, the Austrian, the Siemens and Halskie's, and the Hindostan Insulators—Tightening the Wires in Asia, England, and on the Continent 529

CHAPTER XL.

PARATONNERRE, OR LIGHTNING ARRESTER.

Lightning on the Telegraph—Highton's Paratonnerre—Beid's American Paratonnerre—Various Apparatuses on American Lines—Attachment of Paratonnerres at River Crossings—Incidents of Lightning striking the Line—Steinheil's, Fardley's, Meisner's, Nottebohn's, Breguet's, the French, and Walker's Paratonnerres 564

CHAPTER XLI.

SUBTERRANEAN TELEGRAPHS.

Subterranean Lines in America, Prussia, Russia, Denmark, and France—Lines in Great Britain—Underground Lines in Hindostan—Mode of Testing Subterranean Telegraphs Repairing the Insulated Wires..... 587

CHAPTER XLII.

AMERICAN SUBMARINE TELEGRAPHS.

Disasters to Mast Crossings over Rivers—Adoption of Submarine Cables—Submarine Cables Perfected—Submerging of the Cable—Bishop's Submarine Cables—Chester's Cable Manufactory—Leaden-Covered Telegraph Wires..... 599

CHAPTER XLIII.

EUROPEAN SUBMARINE TELEGRAPHS.

The English and French Cables—Mode of Shipping and Submerging Cables—Holyhead and Howth Telegraph—The Irish Channel Cable of 1852—The English and Belgian Submarine Telegraph—Donaghadee and Port Patrick Submarine Line—English and Holland Submarine Cable—Prince Edward's Island Cable—Danish Baltic Sea Telegraph—The Gulf of St. Lawrence Telegraph—The Balize, Hudson, and Zuyder Zee Cables—The Black Sea Telegraphs—The Mediterranean Submarine Telegraph Lines..... 607

CHAPTER XLIV.

ATLANTIC OCEAN TELEGRAPHY.

The Atlantic Telegraph Company Organized—Principles of Philosophy Presumed by the Company—The Expedition for Laying the Cable in 1857—The First Expedition of 1858—The Second Expedition of 1858—Working of the Telegraph Cable—Cause of the Failure of the Cable to operate..... 622

CHAPTER XLV.

OCEAN TELEGRAPHY.

The Depths of the Ocean—Description of the Brooks Lead—The Elements of the Ocean—Maury's View of a Deep Sea Cable—Atlantic Telegraphs Projected... 649

CHAPTER XLVI.

TELEGRAPH CROSSINGS OVER RIVERS.

Telegraph Crossings in Europe—The Great Crossing over the River Elbe—Wide Spans of Wire on the Continent—River Crossings in America—Description of the Great Mast on the Ohio River—Suspension of the Wire over the Masts—A Western Frontier Telegraph Crossing 657

CHAPTER XLVII.

CONSTRUCTION OF THE AMERICAN LINES.

Organization for Digging the Holes—Erection of the Poles—Suspension of the Wire—Insulating the Poles..... 668

CHAPTER XLVIII.

THE TIMBER AND PREPARATION OF TELEGRAPH POLES.

- The Size, Preparation, and Durability of Telegraph Poles, including the Red-Cedar, White-Cedar, Walnut, Poplar, White-Oak, Black-Oak, Post-Oak, Chestnut, Honey-Locust, Cotton-Wood, Sycamore, and other Timbers 681

CHAPTER XLIX.

POLES ON THE FRENCH TELEGRAPH LINES.

- Preparation of Poles on the French Lines—Injection with Sulphate of Copper—Size Cost, and Durability of different Kinds of Wood 688

CHAPTER L.

POLES ON THE ENGLISH AND OTHER EUROPEAN LINES.

- Baltic Squared Timber—Saplings of Larch, Pine, Spruce, &c.—Poles on the Hindostan Line—Bamboo, Iron-Wood, Teak, Saul, and other Timbers—Their Preparation and Durability 696

CHAPTER LI.

REPAIRING OF TELEGRAPH LINES.

- Qualification and Duties of Repairers—Continuous and Uniform Metallic Conductors—The Joining of Telegraph Wire—Repairing a Break of the Line Wire—The Interruption of the Line by the Falling of Trees—The Great Sleet of 1849, and the Telegraph Lines—Destruction of the Telegraph Lines by Lightning—A Silk Cord Splice found in the Line—Novel Cases of Repairing the Line—Removal from the Line of all Foreign Conductors—To preserve the Insulation of Wire—To Secure the Permanency of the Structure of the Line 701

CHAPTER LII.

IMPROVEMENTS IN TELEGRAPH APPARATUS.

- Kirchhof's, Farmer's, Hughes', Partridge's, Baker's, Coleman's, Channing's, Smith's, Clay's Woodman's, Humaston's, and Wesson's, Patented Improvements in Telegraphing 718

CHAPTER LIII.

ELECTRIC TIME-BALL.

- Utility of Electric Time-Balls for Correction of Chronometers—Nelson's Monument and Time-Ball 741

CHAPTER LIV.

ORGANIZATION AND ADMINISTRATION OF AMERICAN TELEGRAPHS.

- Organization of Telegraph Lines—Organization of Companies—Charter—By-Laws—Office Regulations—Rules for Sending and Receiving Messages—Lines in British Provinces—Patent and Parliamentary Monopolies 745

CHAPTER LV.

ADMINISTRATION OF AMERICAN TELEGRAPHS.

Tariff on Dispatches in America—Words Chargeable and Free—Arrangement of Local Tariffs—Qualifications of Employés—Protection of the Telegraph—Secrecy of Dispatches—Penalty for Refusing to Transmit Despatches—Patent Franchise Inviolable—The Right of Way for Telegraphs 768

CHAPTER LVI.

ORGANIZATION AND ADMINISTRATION OF EUROPEAN TELEGRAPHS.

The Telegraph in France—Decreets permitting the Public to Telegraph—Regulations on receiving and transmitting Dispatches—Conditions of Admission of Supernumeraries—Programme of Preparatory Education required of Candidates 768

CHAPTER LVII.

ADMINISTRATION OF RUSSIAN TELEGRAPHS.

Russian Government Telegraph—Categorical Arrangement of Dispatches—Regulation for Receiving and Sending Dispatches—Classification and Tariff of Charges—Regulation of the Clocks 777

CHAPTER LVIII.

EUROPEAN INTERNATIONAL TARIFFS.

European International Tariff—English International Tariff—Rules and Regulations—The French Range 784

CHAPTER LIX.

ORGANIZATION AND ADMINISTRATION OF ASIATIC TELEGRAPHS.

History of the Telegraph in Hindoestan—Rules and Regulations on the Bengal Lines—Classification and Qualification of Employés 799

APPENDIX.

BIOGRAPHICAL SKETCHES OF EMINENT TELEGRAPHERS,

SAMUEL F. B. MORSE, OF NEW-YORK 808
 AMOS KENDALL, OF THE DISTRICT OF COLUMBIA 808
 FRANCIS O. J. SMITH, OF MAINE 811
 WILLIAM M. SWAIN, OF PENNSYLVANIA 822
 WILLIAM TANNER, OF ALABAMA 825
 JOHN J. SPEED, JR., OF MICHIGAN 829
 JEPHTHA H. WADE, OF OHIO 831
 LEVI L. SADLER, OF MASSACHUSETTS 833
 ANSON STAGER, OF OHIO 837
 TALLAFERRO P. SHAFFNER, OF KENTUCKY 840

TELEGRAPH CHESS-BOARD

57	58	59	60	61	62	63	64
56	55	54	53	52	51	50	49
41	42	43	44	45	46	47	48
40	39	38	37	36	35	34	33
25	26	27	28	29	30	31	32
24	23	22	21	20	19	18	17
9	10	11	12	13	14	15	16
8	7	6	5	4	3	2	1

THE TELEGRAPH.

CHAPTER I.

The meaning of the term Telegraph—Divine Telegraph—Telegraphs mentioned in the Classics and Ancient History—The Telegraph invented by Polybius—Agamemnon's Telegraph, B. C. 1084—North American Aboriginal Telegraph—The American Revolutionary Army Signals.

THE MEANING OF THE TERM TELEGRAPH.

TELEGRAPH—Greek, $\tau\eta\lambda\epsilon$, at a distance, and $\gamma\rho\acute{\alpha}\phi\omega$, to write.

The original meaning of the word, as taken from the Greek, is to perform the act of writing at a distance. In its modern application it means the art of "communicating at a distance." For example, the semaphore telegraph, composed of angles, communicated intelligence by certain mechanical contrivances, which had to be seen and understood by the operator miles distant. Also the needle systems of the electric telegraphs of Europe: they do not write, yet they communicate to points far distant. The term has been applied to any and all systems of transmitting information by signs or sounds to another beyond the reach of speech.

The art of conveying intelligence by the aid of signals has been practised for centuries, and for aught we know since Adam and Eve commenced their pioneer career in the Garden of Eden.

I have searched the Bible in vain for some tangible mode of signaling among the early nations. The most definite reference to communicating by signals mentioned in the Old Testament is to be found in chapter vi., verse 1, of the prophet Jeremiah, viz.: "O, ye children of Benjamin, gather yourselves to flee out of the midst of Jerusalem, and blow the trumpet in Tekoa, and set up a *sign of fire* in Beth-haccerem; for evil appeareth out of the north, and great destruction!"

The writings of Jeremiah date 588 years before Christ, and the above reference to communicating intelligence to others by the "*sign of fire*," or by any means of signaling is the earliest on reliable record.



DIVINE TELEGRAPH.

In the New Testament there is nothing more potent and more sublime than the signal placed in the heavens to indicate that the Son of God was born. The humble shepherds in the open fields of Judea, while guarding their flocks, beheld in the vaulted firmament a **STAR**, the brilliancy of which had no twin. It was a signal—a Divine signal—communicating to man the glad tidings of the birth of the Prince of Peace.



The Gospel of St. Matthew teaches that the signal light suspended in the heavens by the hand of the Creator was seen by the wise men of the east :

“Now when Jesus was born in Bethlehem of Judea, in the days of Herod the king, behold, there came wise men from the east to Jerusalem,

“Saying, Where is he that is born King of the Jews? for we have seen his star in the east, and are come to worship him.”

TELEGRAPHS MENTIONED IN THE CLASSICS AND ANCIENT HISTORY.

In profane history and the classics, various methods of communicating by signals are mentioned.

Homer is the first who mentions the telegraphic art. He compares the lambent flame which shone round the head of Achilles, and spread its lustre all round, to the signals made in besieged cities by clouds of smoke in the daytime, and by bright fires at night, as certain signals calling on the neighboring states for assistance, or to enable them to repel the powerful efforts of the enemy.

Julius Africanus minutely details a mode of spelling words by a telegraph. It appears that fires of various substances were the means made use of. He says the Roman generals had recourse to such media of distant communication. In Livy, in Vegetius, and in the life of Sertorius, by Plutarch, it is mentioned that these generals frequently communicated by telegraphs.

In book iv., page 238, of Brumoi's account of the *Theatres of the Greeks*, it is stated that fire signals were used to communicate the events of wars, and likewise to direct the commencement of battles. This description of signals was anterior to the use of trumpets. A priest, crowned with laurels, preceded the army, and held a lighted torch in his hand. He was respected and spared by the enemy, even in the heat of battle. Hence the old proverbial expression for a complete defeat, that *even the very torch-bearer had not been spared*. Hence, also, it is highly probable that the usage arose of representing discord with inflamed torches.

The Chinese, like the ancient Scythians, communicated intelligence by lighting fires or raising a cloud of smoke at different stations. Polybius gives the general appellation of *Pyrusia* to the telegraphic modes then practised; indicating that *fires* were the principal means made use of. An ingenious though limited species of telegraph was invented by Æneas, who lived in the time of Aristotle, and who wrote on the duties of a general. Two oblong boards had various sentences written on

their surfaces, as, "*The enemy have entered the country,*" "*The invasion has been repelled,*" "*The enemy are in motion,*" &c., &c. These boards were fixed perpendicularly in pieces of cork which fitted very nearly the mouth of two similar circular vessels filled with water, and having a cock adapted to each vessel. One of the vessels was stationed where the intelligence *originated*, and the second at the place to which it was to be *conveyed*. A person, as at present, was always on the lookout; and when he perceived one or more torches raised up at the primary station, he understood that intelligence was about to be communicated. On observing a second torch raised, he *instantly* answered the signal and opened or turned the cock of the vessel he was in charge of; the cock of the vessel at the primary station having been turned immediately on raising up the second torch at that station and on observing this signal answered. As the cocks were opened *simultaneously* at both stations, the circular corks with the board standing perpendicular to their respective centres, would descend in the vessels *equally*, as the water *subsided*. At the *instant* when the sentence to be communicated descended or sunk to the level of the edge of the vessel at the primary station, the person in charge there raised a torch. The person at the second station, on observing this, *instantly* answered this signal, and turned the cock of his vessel, and thus stopped the flowing of the water, reading at the same time the sentence then level with the edge of the vessel, such sentence, on account of the equal flow of the water, corresponding to the one, similarly situated at the original station.

TELEGRAPH INVENTED BY POLYBIUS—PUNIC WAR, B. C. 264.

Polybius writes, in his history of the Punic wars, that he improved a mode of communicating ideas by the letters of the alphabet applied to a telegraph invented by Cleoxenus, or according to some authors, by Democlitus. The letters of the Greek alphabet were divided into five parts, and those in each division were inscribed on a board fixed perpendicularly to an upright post for each of those divisions of the alphabet. These posts stood in an opening between two walls about ten feet by six, and situated on each side of the posts. Two long tubes (a dioptical instrument) were fixed in one position or direction. The telegraph workers could readily perceive through these tubes, which excluded all lateral rays, the right or left of the station viewed, and what number of torches might be raised above the top of the wall, either on the right or left of the station looked to. Things being thus prepared at the primary

and second station, the person in charge at the primary station would raise up two torches as a commencing signal that intelligence was about to be conveyed.

The looker-out at the other station would, on perceiving this, hold up a couple of torches, thus indicating that he was prepared. The ideas to be communicated were reduced previously to as few words as possible. The posts on which the letters were, being numbered 1, 2, 3, 4, and 5, one or more torches raised up above the left-hand wall, would indicate to the person at the second station, on what post was situated the first letter of the sentence to be communicated. The person at the second station, on observing through one of his tubes the torch or torches held up, would immediately raise torch or torches corresponding to the display exhibited. The person at the primary station, seeing his signal taken up, would lower his torch or torches, which would at once disappear on sinking under the level of the top of the wall. The column on which the letter was, being thus ascertained, the person at the primary station would hold up from behind the right-hand wall, a torch or torches, indicating the position of the letter on the post already pointed out. For instance, if it was the first letter at the top of the column, he would hold up one torch, and if the second, two torches, and so on to the fifth letter on the column. The person at the second station would exhibit a corresponding number, to make it appear that he understood the signal. Every letter in each word would be communicated in this manner; and we are to suppose that an agreed-on signal would be made to indicate the termination of a word and of a sentence. It is further evident that information could be conveyed along *any number* of stations, on the principle of the modern telegraph of *keeping up* every signal until *taken up* at the succeeding station. But in this case two parallel walls would be requisite on each side of the posts, in order that the torches, when depressed, might disappear to the two contiguous stations at the same instant. This was a night telegraph; but it could obviously and readily have been converted into a *day telegraph* by substituting *flags* in lieu of *torches*.

AGAMEMNON'S TELEGRAPH, B. C. 1084.

Æschylus, who was born five hundred and twenty-five years before Christ, wrote a tragedy in which he gave an account of the fall of Troy, which occurred 1084 years before the Christian era. For ten years the city had been besieged by Agamemnon. The news of the memorable event was signaled to his queen, Clytæmnestra. The following is from Æschylus:

“WATCHMAN. I pray the gods a deliverance from these toils, a remedy for my year-long watch, in which, couching on my elbows on the roofs of the Atreidæ, like a dog, I have contemplated the host of the nightly stars, and the bright potentates that bear winter and summer to mortals, conspicuous in the firmament. And now I am watching for the signal of the beacon, the blaze of fire that brings a voice from Troy, and tidings of its capture; for thus strong in hope is the woman’s heart, of manly counsel. Meanwhile I have a night-bewildered and dew-drenched couch, not visited by dreams, for fear, in place of sleep, stands at my side, so that I cannot firmly close my eyelids in slumber. And when I think to sing or whistle, preparing this the counter-charm of song against sleep, then do I mourn, sighing over the sad condition of this house, that is not, as of yore, most excellently administered. But now, may there be a happy release from my toils as the fire of joyous tidings appears through the gloom. Oh hail! thou lamp of night, thou that displayest a light as like the day, and the marshalling of many dances in Argos on account of this event. Ho! ho! I will give a signal distinctly to the wife of Agamemnon, that she, having arisen with all speed from her couch, may raise aloud a joyous shout in welcome to this beacon, if indeed the city of Ilion is taken, as the beacon light stands forth announcing; and I myself will dance a prelude. For I will count the throws of my lord that have fallen well; mine own, since this kindling of the beacon light, has cast me thrice six. May it then befall me to grasp with this hand of mine the friendly hand of the sovereign of this palace on his arrival.

* * * * *

CHORUS. But thou, daughter of Tyndarus, Queen Clytæmnestra, what means this? What new event? What is it that thou hast heard? and on the faith of what tidings art thou burning incense sent around? And the altars of all our city-guarding gods, of those above and those below, gods of heaven and gods of the forum, are blazing with offerings; and in different directions different flames are springing upward, high as heaven, drugged with the mild, unadulterated cordials of pure ungent, with the royal cake, brought from the inmost cells. Concerning these things, tell one both what is possible and lawful for thee to say, and become thou the healer of this distracting anxiety, which now, one while, is full of evil thought, but at another time, because of the sacrifices, hope blandly fawning upon me repels the insatiate care, the rankling sorrow that is preying upon my heart. * * *

I have come revering thy majesty, Clytæmnestra; for right

it is to honor the consort of a chieftain hero, when the monarch's throne has been left empty. And gladly shall I hear whether thou, having learned aught that is good or not, art doing sacrifice with hopes that herald gladness—yet not if thou countest silent will there be offence.

CLYTEMNESTRA. Let morning become, as the adage runs, a herald of gladness from its mother night; and learn thou a joy greater than thy hope to hear, for the Argives have taken the city of Priam.

CH. How sayest thou? thy word escaped me from its incredulity.

CLYT. I say that Troy is in the power of the Argives—speak I clearly?

CH. Joy is stealing over me, that calls forth a tear.

CLYT. Ay, for thy countenance proves thy loyalty.

CH. Why, what sure proof hast thou of these things?

CLYT. I have a proof—why not?—unless the deity hath deluded me.

CH. Art thou then reverencing the vision of dreams that win easy credence?

CLYT. I would not take the opinion of my soul when sunk in slumber.

CH. But did some wingless rumor gladden thy mind?

CLYT. Thou sharply mockest my sense as that of a young girl.

CH. And at what time hath the city been sacked?

CLYT. I say in the night that hath now brought forth this day.

CH. And what messenger could come with such speed?

CLYT. Vulcan, sending forth a brilliant gleam from Ida; and beacon dispatched beacon of courier-fire hitherward. Ida, first, to the Hermæan promontory of Lemnos, and third in order Athos, mount of Jove, received the great torch from the isle, and passing o'er so as to ridge the sea, the might of the lamp as it joyously travelled, the pine-torch transmitting its gold-gleaming splendor, like a sun, to the watch towers of Macistus. And the watchman omitted not his share of the messenger's duty, either by any delay, or by being carelessly overcome by sleep; but the light of the beacon coming from afar to the streams of the Euripus gives signal to the watchmen of Messapius, and they lighted a flame in turn and sent the tidings onward, having kindled with fire a pile of withered heath. And the lamp in its strength not yet at all bedimmed, bounding over the plain of the Asopus, like the bright moon to the crag of Cithæron, aroused another relay of the courier fire. And

the watch refused not the light that was sent from afar, lighting a larger pile than those above mentioned; but it darted across the lake Gorgopis, and having reached mount Ægiplanctus, stirred it up that the rule of fire might not be stint, and lighting it up in unscanting strength, they send on a mighty beard of flame, so that it passed glaring beyond the headland that looks down upon the Saronic frith, then it darted down until it reached the Arachnæan height, the neighboring post of observation, and thereupon to this roof of the Atreidæ here darts this light, no new descendant of the fire of Ida. Such, in truth, were my regulations for the bearers of the torch fulfilled by succession from one to another; and the first and the last in the course surpass the rest. Such proof and signal do I tell thee of my husband having sent me tidings from Troy.

CH. To the gods, my queen! I will make prayer hereafter, but I could wish to hear and to admire once more, at length, those tidings as thou tellest them.

CLYT. On this very day the Greeks are in possession of Troy. I think that a discordant clamor is loud in the city. If you pour into the same vessel both vinegar and oil, you will pronounce that they are foemen, and not friends. So you may hear the voices of the captured and the conquerors distinct because of a double result; for the one party having fallen about, the corpses of men, both those of brothers, and children those of their aged parents, are bewailing, from a throat that is no longer free, the death of those that were dearest to them. But the other party, on the contrary, is hungry, fatigued from roaming all the night after the battle, arranging at meals of such things as the city furnishes, by no fixed law in the distribution, but as each hath drawn the lot of fortune. Already are they dwelling in the captured houses of the Trojans, freed from the frost beneath the sky, and from the dews, thus will they, poor wretches, sleep the whole night through without sentries."

NORTH AMERICAN ABORIGINAL TELEGRAPH.

The most remarkable signaling records are to be found on various parts of the North American continent. The aborigines, or a race of people centuries since extinct, had their signal stations or mounds. Upon the loftiest summits beacon fires were built, and the rising smoke by day and the red flame by night communicated intelligence to others far distant. These mounds, these beacon remains, are still to be seen in different parts of America. An eminent author upon this subject says, that the most commanding positions on the hills bordering the



valleys of the west, are often crowned with mounds, generally intermediate, but sometimes of large size; suggesting at once the purposes to which some of the *cairns* or hill-mounds of the Celts were applied, namely, that of signal or alarm posts. Ranges of these mounds may be observed extending along the valleys for many miles. Between Chillicothe and Columbus, on the eastern border of the Scioto valley, not far apart, some twenty may be selected, so placed in respect to each other, that it is believed, if the country was cleared of the forest, signals of fire might be transmitted in a few minutes along the whole line. On a hill opposite Chillicothe, nearly six hundred feet in height, the loftiest in the entire region, one of these mounds is placed. A fire built upon it would be distinctly visible for fifteen or twenty miles up, and an equal distance down the valley.

In the Miami valley similar works are found. Upon a hill three hundred feet in height, overlooking the Colerain work, and commanding an extensive view of the valley, are placed two mounds, which exhibit marks of fire on and around them. Similar mounds occur at intervals along the Wabash and Illinois, as also on the Upper Mississippi, the Ohio, the Miamis, and Scioto. On the high hills, overlooking Portsmouth and Marietta, mounds of stone are situated; those of the former place exhibit evident marks of fire.

These mounds, or beacon hills, are to be found in different parts of the continent. The remains of these beacon fires are silent records left by a people, long since gone. Above the cinders have grown stately oaks, and upon the surface of the earth nothing but the new soil is to be seen. On removing the

earth some few feet, the charcoal and ash beds are found. How many centuries they have been there no human being can divine. It remains a sealed history to the world.

The savage Indians, that rove in the wild regions of America, have their means of communicating by beacons and other modes of signaling. When Lieut. Fremont penetrated into the fastnesses of Upper California, his appearance created an alarm among the Indians. He there observed the primitive telegraph communicating his presence to tribes far distant. In his report, he says: "Columns of smoke rose over the country at scattered intervals—signals, by which the Indians, here, as elsewhere, communicate to each other, that enemies are in the country. It is a signal of ancient and very universal application among barbarians."

AMERICAN REVOLUTIONARY ARMY SIGNALS.

During the American Revolutionary war, the people had their modes of signaling to each other the movements of the enemy, and especially when they were approaching. Among the different plans of communicating between the divisions of the army, was the next representation, of a barrel at the head of a mast, a flag below it, and the basket hanging to a cross-beam. This mast was moveable. The parts were moveable, and any arranged system of signaling could be carried out by this simple contrivance. For example, suppose the enemy was approaching, the pole might be left bare, so that there would be no reason for the enemy to suspect the objects of its use. The basket or either of the others, alone or combined, or any transposition, could be made to communicate a variety of information.

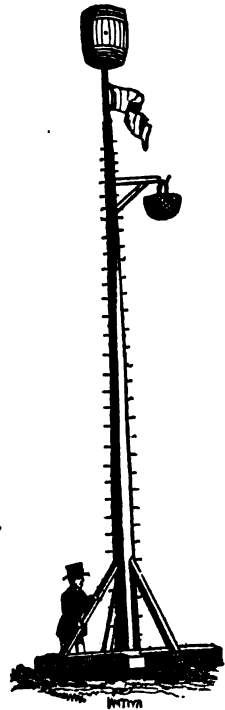

THE SEMAPHORE TELEGRAPH.

CHAPTER II.

Origin of the Semaphore Telegraph—Its Adoption by the French Government—Its Extension over Europe—A German Telegraph Station—Russian Telegraph.

ORIGIN OF THE SEMAPHORE OR AERIAL TELEGRAPH.

THE visual telegraph system, of late in universal use over Europe and a part of Asia, has been superseded by the electric system. Notwithstanding it has passed away, yet a description of its beautiful mechanism must ever be of interest to the telegrapher. The most perfect aerial telegraph was that invented by the Messrs. Chappé, and first adopted in France.

There were three brothers Chappé, nephews of the celebrated traveler, Chappé d'Auteroche, who were students—one at the Seminary d'Angers, and the other two were at a private school about a half league from the town. Claude Chappé, the pupil of the seminary, wishing to alleviate the separation with his brothers, contrived the following means by which they might correspond one with the other.

He placed at the two ends of a bar of wood two wing pieces of wood, to be moved at pleasure, by means of which he was enabled to produce 192 signals, which were distinctly visible by means of a spy-glass. He conceived the idea of making words of these signals, and he communicated the same to his two brothers. This took place a few years before the French revolution in 1793. His invention was first tried in 1791, but, like all inventors, Chappé met with great opposition and discouragement. The people were opposed to the use of the telegraph at all, and his first telegraphs and the stations were destroyed by the populace. His second telegraph shared the same fate, and was burnt to the ground, and poor Chappé narrowly escaped with his life; the people threatened to burn him with his telegraph. Not daunted by these misfortunes he renewed his efforts for government aid, with increased zeal, until success crowned his efforts.

ADOPTION OF THE SEMAPHORE TELEGRAPH IN FRANCE.

Continuing his efforts with the zeal common to great inventors, he finally succeeded in getting the government to favor his project, and a commissioner was appointed to examine into it. The commissioner reported favorably, and his system was adopted, and Chappé was honored with the appointment of telegraphic engineer to the French government.

Fortunately, before the presentation of the invention to the government, the Chappé brothers perfected the system entire, and in the preparation of the signals they had the aid of Leon Delaunay, who had formerly been consul, and who was well acquainted with the cipher language of diplomacy. In this perfect state it was presented to the convention, adopted and subsequently executed. Circumstances favored these inventors remarkably; for their telegraph, after it had been once adopted by the government, it was fortunately inaugurated by the announcement of a victory. The following was the first dispatch, having been transmitted by the telegraph from the frontier of France to Paris, viz. :

"CONDE IS TAKEN FROM THE AUSTRIANS."

To which the convention, then in session, responded as follows, viz. :

"THE ARMY OF THE NORTH DESERVES THE GRATITUDE OF THE
COUNTRY."

These two dispatches ran like an electric shock through the convention, and soon thereafter throughout Paris. The Chappé telegraph was then the pride of the nation! The telegraph and the victory were rejoiced over as twin-sisters in French glory. From this time the telegraph spread with wonderful rapidity to all parts of France, and thence to the other governments of Europe. The line from Paris to Lille was constructed in 1794, and two minutes only were occupied in the transmission of a dispatch.

In the perfection of the beautiful mechanism for the production of the signals, Chappé had the invaluable assistance of that most ingenious mechanic, M. Breguet, whose fame as a watch-maker had spread throughout Europe

EXTENSION OF THE SEMAPHORE TELEGRAPH OVER EUROPE.

After the perfection of the semaphore telegraph in France, its usefulness was observed by the other governments of Europe. In 1802, a modified system was adopted in Denmark. About the same time it was adopted in Belgium. About 1795, it was

adopted in Sweden, with some improvements over the Chappé system of that time. Soon after the establishment of the lines in France, the telegraph was erected in some parts of Germany. But the mechanism of the stations of that day was not so perfect as it has since been made by the brothers Chappé, and as will be described hereafter. In 1823, the visual telegraph was established between Calcutta and the fortress of Chunore, in Asia. A year later it was erected between Alexandria and Cairo, in Egypt, by Mohammed Ali. In some form or other it has spread mostly over the inhabited globe.

Fig. 1.

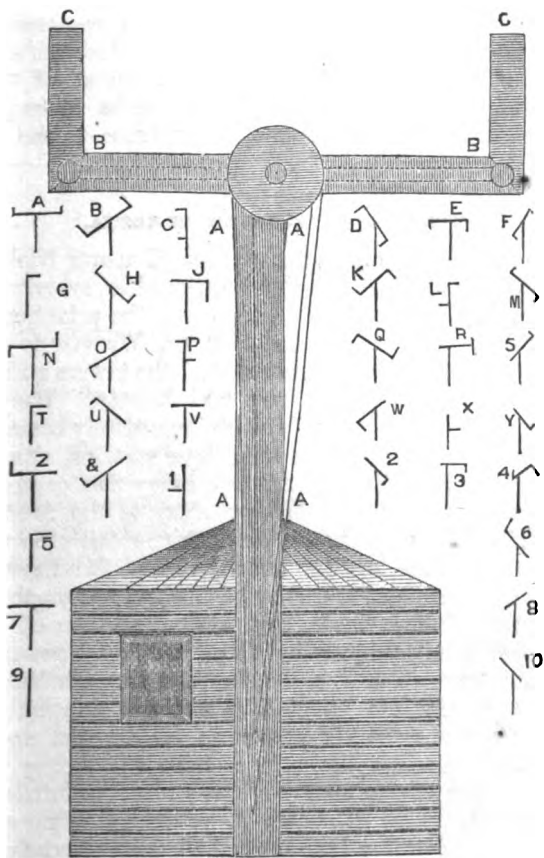

German Telegraph Station, 1798.

THE GERMAN TELEGRAPH STATION.

While at Frankfort on the Main, Germany, in 1854, I found a drawing of the ancient semaphore telegraph, used in that country more than a half century ago. The house or station was a plain hut, and the mechanism for manipulation very simple, as will be seen in figure 1. The ropes were drawn by the hand, moving the regulator *B B*, and the indicators *B C*, as desired. The position of the regulator and the indicators, in the figure above, forms the letter *A*. Suppose the indicators *A C* were let down so as to hang below *B B*, the position then would form the letter *E*. The different angles assumed by the regulator and the indicators form letters, as illustrated by the alphabet given in figure 1. *A A* is an upright post made permanent in the earth or to the house. The descending cords move *B B* and *B C* separately. The organization of the mechanism, and the mode of manipulation, will be more particularly described in the next chapter, in reference to the Chappé telegraph.

THE SEMAPHORE TELEGRAPH IN RUSSIA.

It was not until the reign of the great Emperor Nicholas I., that Russia organized a complete telegraphic system, which was executed in the most gigantic style in the principal directions required by the government. From Warsaw to St. Petersburg, to Moscow, and on other routes, the towers and houses were constructed for permanency and beauty. They were neatly painted, and the grounds were beautifully ornamented with trees and flowers. I have seen these stations, situated on eminences along the routes mentioned, every five or six miles, and the towers were in height according to the face of the country, and sufficiently high to overlook the tall pine so common in Russia. The system employed was, like those of all the other governments of Europe, the Chappé telegraph.

The erection of these towers cost several millions of dollars, and the expense of maintaining them was very great. The line from the Austrian or Prussian frontier, through Warsaw to St. Petersburg, required about 220 stations, and at each of these stations were some six employés, making an aggregate of 1,320 men. Besides these, there were managing men at different localities having charge of the general administration.

That great Emperor Nicholas I.—ever watchful and progressive—at an early day inaugurated the semaphore telegraph in a manner commensurate with the vastness of his government and its wants; and, notwithstanding the immense cost that it had been to the government, as soon as he saw a superior tele-

graph he adopted it, and bade farewell to the visual signals which had served him so faithfully for a quarter of a century. It was a noble example to the fixedness of the bureau departments of other governments. These stations are now silent. No movements of the indicators are to be seen. They are still upon their high positions, fast yielding to the wasting hand of time. The electric wire, though less grand in its appearance, traverses the empire, and with burning flames inscribes in the distance the will of the emperor to sixty-six millions of human beings scattered over his wide-spread dominions.

Fig. 2.

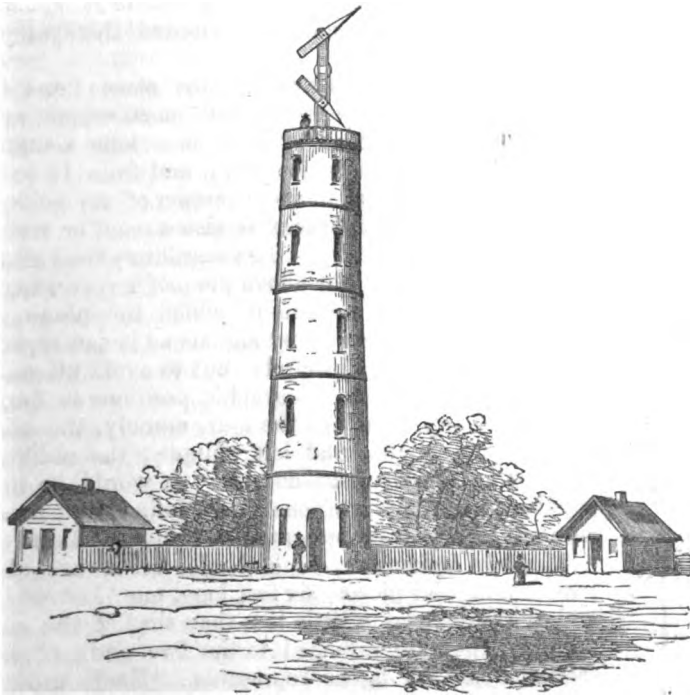

Russian Telegraph Station, 1858.

CHAPTER III.

Description of the Chappé Telegraph—Organization of the Signal Alphabet—
Process of Manipulation—Its Celerity in Sending Dispatches.

DESCRIPTION OF THE CHAPPE SEMAPHORE TELEGRAPH.

I WILL now proceed to describe the Chappé sempahore telegraph according to the modern mode of operating it. The description is from the best authorities, and I presume it will be sufficiently clear, to enable any one to understand the system in its most complete sense.

The Chappé telegraph is composed of three pieces: one is large and called a regulator, and two small ones, which are called indicators. The regulator *A B*, fig. 1, is a long rectangular piece, 13 inches wide and 14 feet long, and from $1\frac{1}{2}$ to 2 inches thick. At its centre, and in the direction of its centre, it is traversed by an axis, which traverses also a mast or vertical post *D D* at its upper extremity. The regulator, thus situated and elevated little over 14 feet above the roof *T T*, can turn freely on its axis, and describe a circle of which the plane is vertical. It can therefore give as many signals as it can represent distinguishable diameters of a circle; but to avoid all confusion Chappé wisely reduced its telegraphic positions to four, and it can never take any other but the four, namely, the vertical, horizontal, right oblique, and left oblique; the oblique

Fig. 4. forming an angle of 45 degrees. It would be impossible to find four positions better defined and more distinct. They are represented in figs. 2, 3, 4 and 5.



Fig. 5.

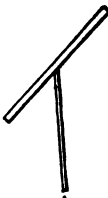

The two indicators *A C* and *B C*, fig. 1, are also two rectangular pieces, six feet long, one foot wide, and of a thickness a little less than that of the regulator. They are attached to the two ends of the regulator as the figure represents. Each indicator has at its extremity *A* and *B* an axis which traverses the regulator at the same point. The extremity *C C* is free and moveable, each indicator can therefore describe a circle, of which the plane is parallel to the plane of the circle, which the regulator may describe; thus, in this manner, all the signals are made in the same way, vertical and perpendicular to the line of vision.

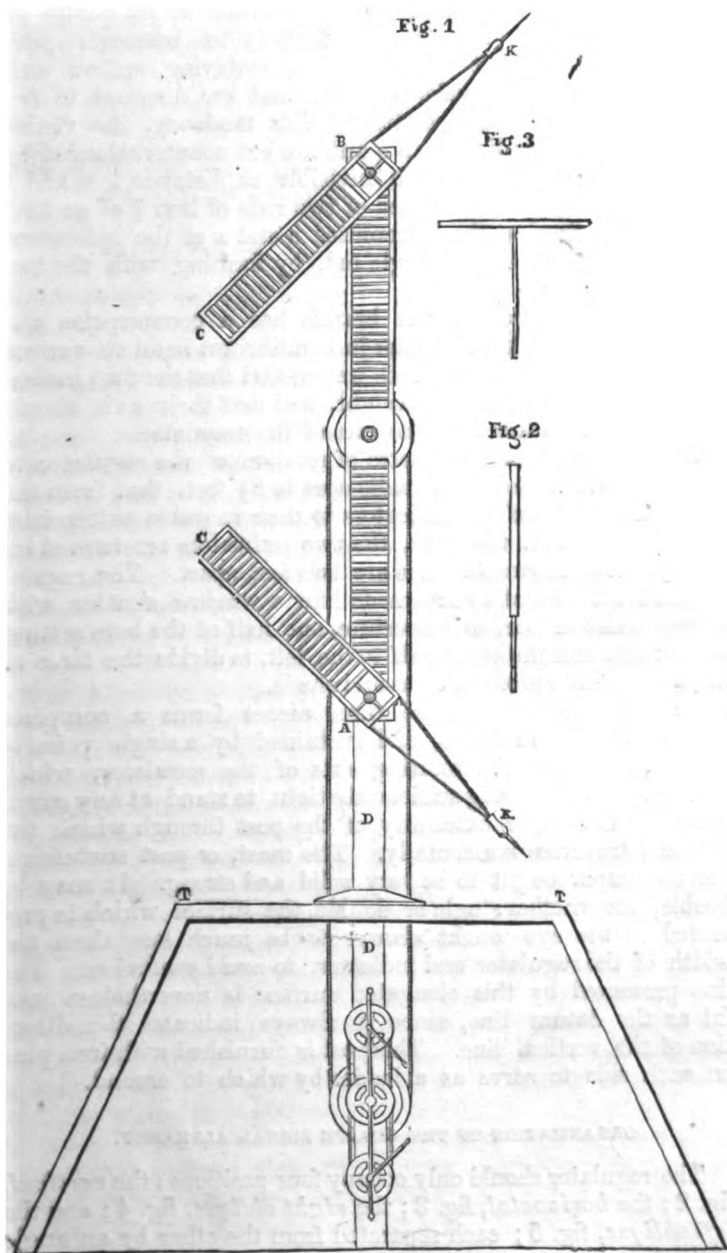

The regulator having its axis of rotation at its centre of form and gravity, remains indifferently in whatever position it is put; but the indicator, revolving on an axis placed at one of the ends, are free, and are disposed to fall toward the earth. To counteract this tendency, the visible branches of the indicators *bc* and *ac* are counterbalanced by a weight placed on a branch invisible at distance *ak* and *bk*. This branch at first formed of two rods of iron $\frac{3}{4}$ of an inch in diameter, fixed at the extremities *b* and *a* of the indicators, was soon changed into a single rod, by forming with the two an acute angle.

Toward its extremity the branch has a counterpoise *k* of lead, which keeps the indicator in equilibrium in all its various positions around its axis. It is understood that the two indicators should be of the same weight, and that their axis should be at equal distances from the axis of the regulator.

The distance from the centre of rotation of the regulator to the centre of rotation of the indicators is $6\frac{1}{2}$ feet, that from the centre of rotation of the indicators to their movable extremities is $5\frac{1}{2}$ feet; when, therefore, the two indicators are turned inwardly, their moveable ends are two feet apart. The regulators and the indicators are made like a window shutter with alternate slot or bar, and aperture, one half of the bars setting to the right and the other half to the left, to divide the force of the wind, and to produce light and shade.

The assemblage of these three pieces forms a complete whole, elevated in space, and sustained by a single point of support, namely, the rotating axis of the regulator, which axis turns with a hug sufficiently tight to stand at any given point, at the upper extremity of the post through which the said axis traverses horizontally. The mast, or post sustaining the telegraph, ought to be very solid and strong. It may be double, but whether single or double, the surface which is presented to the eye ought always to be much less than the width of the regulator and indicator, to avoid confusion. The line presented by this elongated surface is nevertheless useful as the datum line, since it always indicates the direction of the vertical line. This post is furnished with iron pins on each side to serve as a ladder by which to ascend.

ORGANIZATION OF THE CHAPPE SIGNAL ALPHABET.

The regulator should only occupy four positions: the *vertical*, fig. 2; the *horizontal*, fig. 3; the *right oblique*, fig. 4; and the *left oblique*, fig. 5; each separated from the other by an angle of 45 degrees.

Let us now suppose the regulator placed in a horizontal position, and having a single indicator BE , describe a circle around its axis B , and by stopping it at every 45 degrees we thus give to it 8 different positions in regard to the regulator BA . Of these 8 positions, 6 are angular BL , BM , BN , BF , BE , and BD . Two are parallel BC and BO . This last position has been abandoned, because as it is merely a prolongation of the regulator, it is not seen distinctly.

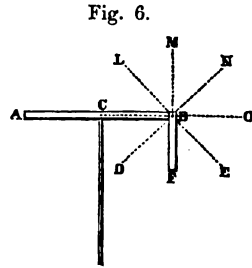

Fig. 6.

The 7 relative positions of the indicator and of the regulator thus give 7 distinct indexes, all combining to form the desired signals. For whatever be the position of the regulator, the indicator is always placed in a horizontal, or vertical, or right oblique, or left oblique position, respectively. Of these seven signals, one, CB , confounds itself with the regulator, and is called zero. Two, BL and BD , form with the regulator an angle of 90 degrees, and two, BN and BF , an angle of 135 degrees. It is necessary, therefore, to find simple means of distinguishing them. In the method adopted for the formation of signals, the indicator in the positions BL , BM , and BN , has always its free extremity turned toward the sky, and its other extremity toward the earth, in the positions BF , BE , and BD . In designating angles, the words sky and earth will be used to avoid prolixity. On the other hand, it would be tedious to say 45 degrees sky, 90 degrees sky, 135 degrees sky or earth. These different terms have been adopted to economize in the language. The terms used are zero, 5 sky, 10 sky, 15 sky, 15 earth, 10 earth, 5 earth, and they are written as indicated in fig. 7.

The regulator being fixed in any Fig. 7 — — — — —
of the four positions which it can
take, a single indicator produces with it 7 distinct and separate signals. It is evident that the indicator placed at the left of it, will produce the same number, and these are called the same, except they are described as at the left of the indicator as seen in fig. 8.

Now, if we consider the signals which may result from the combination of the seven signals of one indicator with the seven signals of the other indicator, we shall see that if one of the indicators is placed at zero, and the other is passed through its seven positions, we shall obtain, in the first place, the double

horizontal, or rather the *horizontal closed line*, then, zero 5 sky, zero 10 sky, zero 15 sky, zero 15 earth, zero 10 earth, and zero 5 earth, as seen in fig. 8.

Elevating and keeping at "5 sky" one of the indicators, we shall have 5 sky zero, two 5 sky, 5 and 10 sky, 5 and 15 sky, 5 sky and 15 earth, 5 sky and 10 earth, 5 sky and 15 earth, which makes 7 other signals, as seen in fig. 9.

Elevating and keeping at "10 sky" one of the indicators, we will obtain seven more signals, and so on, until the seven signals of one indicator have been combined with each of the seven signals of the other, giving in all 49 signals, without changing the position of the regulator; but the regulator takes four different positions, giving four different values to the 49 signals, and raising the whole number of possible signals to 196, furnished by the Chappé semaphore telegraph. These signals are clear, simple, and easy to name and to write. It is impossible to commit an error, on a clear day, in seeing, designating, or writing them. One grave difficulty, however, presented itself in communicating, that is, how to designate to the neighboring station that the signals formed were correct, and how to indicate the time to repeat them.

The brothers Chappé decided that no signals should be formed, with the regulator in a horizontal or perpendicular position; that all signals should be formed on the *right oblique* or *left oblique*. They also decided that no signal should have value until the regulator should be returned to a vertical or horizontal position.

In this way the operator who sees a signal formed on the right or left oblique, notices, and prepares himself to repeat it back to the station; but he does not record it. As soon as he sees it carried to the horizontal or vertical position, he knows it to be correct, and he immediately writes it down, and then repeats it to the same station. This manœuvre is called "verifying the signal." From that time each signal formed on each oblique takes a double value. Since it may be carried to the horizontal or vertical line, 49 signals, there can be received 98 significations in passing from the right oblique to the horizontal or vertical line; and the same for the left oblique, in all 196 signals. Nevertheless, the signals of the two obliques would not be intelligible if the signals of the right oblique were not different from those of the left oblique; for both being brought to the horizontal or vertical line, they being in all respects similar, would really represent only 98 signals, unless we noticed the direction in which they are moved to a horizontal or vertical position.

As the necessity of the telegraph requires a great portion of the signals for the purposes of regulation and police of the line, the rest of the signals being devoted exclusively to the transmission of dispatches, these two classes of signals, being perfectly distinct, cannot be placed in the same journal of business. The signals formed on one oblique are, therefore, devoted to the administration of the line, and those on the other oblique are devoted to the correspondence. There are thus 98 regulation signals, and 98 dispatch signals, which are all written on horizontal and vertical lines, but written separately in the journal book, marked out for the registration of the respective services. The signals take their names

when they are formed on the obliques, as seen in fig. 10, and it is important to remark that the designation of a signal must commence always from the upper extremity of the regulator. The signals are never written as in the table, fig. 10, but always as in the horizontal lines, as in fig. 11, or in the vertical line, as in table, fig. 12. The station master writes them as he sees them, but never until he is sure they are correctly understood. It

now remains to be explained how the mechanism which produces these signals is operated. To one not familiar with signaling, the process may seem surrounded with complications, and tardiness of action. Such, however, is not the case; and a knowledge of the more modern electric needle system of telegraphing would prove the error. But as to the rapidity in transmission, the facts hereafter stated will more fully demonstrate that the Chappé telegraph is not a slow process of communicating intelligence, but that it has subserved well the purposes contemplated by its patriotic and enthusiastic founder.

Fig. 10.

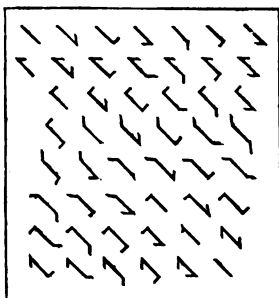

Fig. 11.

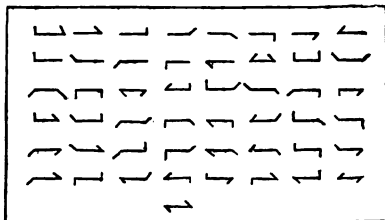
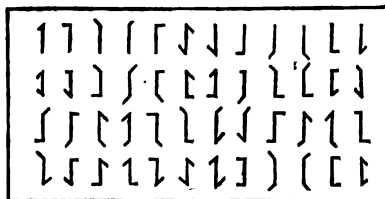

Fig. 12.



THE PROCESS OF MANIPULATING THE CHAPPE TELEGRAPH.

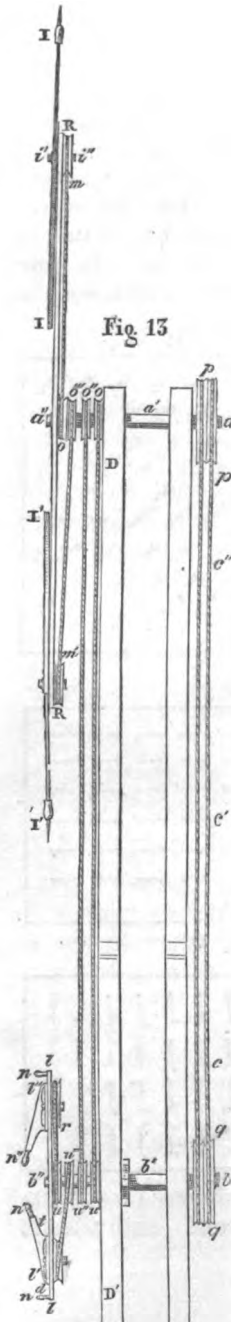

Fig. 13

The axis $a \ a' \ a''$, fig 13, which commands the regulator, is turned by a pulley, p , fixed at its extremity, a , opposite to that of a'' , which carries the regulator; this pulley, from 16 to 18 inches in diameter, contains two deep grooves, and under this pulley in the interior of the post about three feet from the ground is another similar one, q , which also has two grooves. The second pulley, q , is also fixed at the extremity b , of an axis $b \ b' \ b''$, which traverses horizontally the interior prolongation of the post $D \ D'$, figures 1 and 13. In order to receive upon a square b'' , a double lever $l \ l$, which serves to place it in rotation, as well as the pulley fixed at its other extremity. This lever, or double right-hand crank, is about three-and-a-half feet long, and is terminated by two wooden handles situated at right angles from each other, $tn \ tn$. Let us suppose now that the lever which represents a diameter, and describes a circle, the plane of which parallel is to that of the circle described by the regulator; let us suppose, I say, that this lever is fixed, in the first place, parallel with the regulator, and at the moment we transmit to the pulley p the rotatory movement, which it will give to the pulley q by means of two tightly-strained bright wire cords, of which one passes to the right of the two pulleys in one of their two grooves, and the other to the left in the other groove. Suppose now that the free extremities of these two cords are fastened at the bottom of their respective grooves, after having surrounded the upper and lower pulleys by at least half the circumferences, it is evident that the movement described by the lever $l \ l$ will be transmitted by the axis $b \ b' \ b''$ to the pulley q , which will transmit it exactly by means of the two cords $c \ c' \ c''$ to the pulley p ; and that this latter will trans-

mit by the axis $a a' a''$ to the regulator $R R$, and to all the parts which it carries, and that the regulator will also follow the movement of the lever $l l$, and remain perfectly parallel with it. It is also evident that the lever and the regulator may describe at least a circle, because the cords are wound upon each pulley for each half of a circumference at each extremity. As a substitute for the cords, and to give them easily the proper tension which the movement causes them to lose, the middle portion of them, which is never required to pass over the pulley, are iron rods with screws, by which they may be lengthened or shortened at pleasure. These rods are terminated above and below by hooks which hold the cords by a single ring in the end of the cord. The extremity of the cords which answer to the pulleys, traverses the bottom of the groove, through a hole made for that purpose, and is attached to a spoke of the pulley which is shortened or lengthened by means of a screw. By this very simple system a station-master may change very rapidly the cords or the rods, and lengthen or shorten them at pleasure. The rods or cords pass through the roof of the house, through holes, in such a way as to avoid friction as much as possible.

To communicate movement to the indicators, the mechanism is the same as above described, only a little more complicated or extended, because there must be two return cords, one from the extremities, the lever $l l$ at its axis b'' and the other from the axis of the regulator a'' to its extremities $R R$. In the second place the rotary movement must be transmitted to two different and independent circles. Let us consider in the first place, the transmission of the movement to a single indicator.

The indicator is governed by an axis $i' i''$, which also governs the pulley with two grooves m ; this pulley is fastened to the pulley o' by two metallic cords, which renders all their movements dependent and identical; the pulley o' forms a single piece with the pulley o ; these two pulleys are united by a hollow axis traversed by the axis of the regulator $a a' a''$, around which it turns freely. The pulley o , and consequently the pulley o' receives all its movements from the pulley u' , which receives them from the pulley u , to which it is connected by a hollow axis, which turns upon the axis $b b' b''$ of the lever; the pulley u receives its movement from the pulley r ; this last pulley is controlled by an axis which traverses the lever $l l$, in which it turns; the extremity l'' of this axis is fixed to one lever forming the ray $l'' u''$; this lever, or handle or hand, in describing a circle, causes the pulley r to describe a circle in the same

direction, which causes the same result to the pulley u , which in its rotation draws the pulley u' , and this rotation is transmitted to the pulley o , which communicates it to the pulley o' , and this latter causes the pulley m to turn, which causes the regulator r to describe a complete circle in the same direction as the hand $l' n'$ has done. By causing this hand to describe a circle, in an opposite direction, it is easily seen that the indicator will do the same thing. Let us now follow the transmission of the movement to the second indicator.

By causing the hand $l' n'$ to turn, the pulley r is made to turn, which causes the pulley u''' to turn. This pulley forms a single piece with its neighboring pulley u'' , and both turn by means of one common hollow axis; around the common hollow axis of the two pulleys $u u'$, the pulley u'' transmits the movement to the pulley o'' , united by a hollow axis to its neighbor o''' . This hollow axis turns, also, around the hollow axis common to the pulleys o' and o . The pulley o''' puts in rotation the pulley m'' , which makes the indicator $i' i''$ describes identically the same movement which the hand $l' n'$ had made.

If we observe, now, that the large lever $l l$ makes the regulator describe movements similar to its own, and that it draws by these movements the rays $l' n' l'' n''$, without changing the relations established between them and itself, and that the indicators cannot change their relative positions with the regulators, but by change of relation with the said rays of the grand lever, without changing the relation of the said rays to the grand lever, we shall easily understand.

1st. That the rays $l' n' l'' n''$, making any angle with the diameter $l l$, the indicators $i i' i''$ will make precisely the same angles with the regulator $r r$.

2d. Whatever be the horizontal, vertical, right oblique, or left oblique, in which we put the lever $l l$, the regulator will take the same position; and, as this same movement affects no change in the value of the angles formed by $l' n' l'' n''$ with $l l$, the indicators will also remain invariably in their angles with the regulator.

Thus the interior mechanism gives a constant and exact image of the exterior mechanism, and the signals are always reproduced with precision before the eyes of the operator.

In order that the angles of the indicators and of the regulators should be invariably fixed, the hands $l' n' l'' n''$ are furnished with a spring and a tooth. This spring is designed to make the tooth t enter into the notches of the steel dividing circle d . These divisions are seven in number, of 45 degrees

each. The axis of the large lever also carries a divisor of 8 notches; but while the divisors of the two hands are fixed in relation to the axis which traverses them, said divisor of the large lever is fixed upon the axis and turns with it. When we wish to hold the regulator on account of high wind, or for other cause, we place a kind of bolt fixed in the post to enter one of these notches, and this bolt stops all movements of the regulator.

As the indicator ought always to remain motionless, when the regulator is moved after a signal is made, the spring above mentioned always holds the tooth of the hand fixed in the notch of the divisor when said hand has been placed in such a way that the operator is obliged, when he wishes to change the position of an indicator, to draw the hand toward himself in order to disengage the tooth, and to let go of the hand when the tooth has arrived opposite the new notch in which the tooth is to be fixed. From these facts it will be seen that the mechanism of the Chappé telegraph is a model of simplicity and precision. It fulfills the conditions of rapidity, clearness, and variety in execution.

Let us suppose that the telegraph is at rest in the position represented in fig. 13, which position is called the *vertical closed*, and that the operator enters his office in the morning; he commences by applying his eye alternately to first one, and then the other of his neighboring telegraph stations, to see if either of them are giving a signal, and, in the meantime, he arranges on his desk, pen, ink, and record-book.

As soon as he sees one of the two stations move, he draws the bolt which holds the large axis at rest, and puts one hand upon the upper handle of the great crank, and then looks at the signal which has been formed.

If the regulator is to be carried to the right oblique, or left oblique, which is indispensable, he pushes the upper extremity of the handle to the right or left, aiding the movement at the same time by pushing the lower extremity with his leg, at the same time he puts his other hand upon the small lower crank *l' n'* in order to commence moving the indicator; the regulator being once set in motion, he lets go the upper handle in order to take hold of the handle *l'' n''*, and move the second indicator, thus the signal being formed, he stops it on the oblique which belongs to it. He thus looks through his telescope to the station whence the signal came, to see if said signal has been carried to the horizontal or to the vertical. If it has been carried, he knows it to be correct, and accordingly records it as he sees it horizontal or vertical in the square

of signals of correspondence ; if it has been formed on the other oblique, he records the hour and minute at which the labor commences ; and lastly, he makes his own signal, and watches to see if the station to which he communicates the dispatch repeats and carries it correctly. If he is sure that the signal has been well understood and properly reproduced, he turns to the first telescope, repeats the signal which he sees on the oblique, waits till it is carried to the horizontal or vertical, in order to record it, repeats it in his turn, watches if it is correctly taken by the other station, and the operation thus continues indefinitely.

CELERITY OF DISPATCHING BY THE CHAPPE TELEGRAPH.

The greatest speed which can be attained in the passage of signals without producing confusion, is three signals a minute, whence it follows that 20 seconds is necessary to execute all the steps of a signal, to record it, and to verify it. All the signals, however, do not require this period of time, as there are half signals. These half signals are four in number—the double zero or vertical closed, the closed or double horizontal zero, the right oblique closed and left oblique closed. These are all made in their place, and it is only necessary to fold in the two indicators. These demi-signals are very useful, because they serve to distinguish groups of signals ; and, because, being frequently necessary, they waste less time than a signal execution, of which requires several steps and movements. The movements of the regulator are so easy, when the machine is in good order, and there is no wind, that generally the operator can, by using the two hands to develop the indicators, at the same time bring the regulator to the position which it is to occupy.

The complete operation of a signal is as follows : 1st. Observe the signal which is formed on the oblique. 2d. Form it. 3d. Observe if it is carried to the horizontal or to the vertical. 4th. Carry it in a corresponding manner. 5th. Record it. 6th. See if the next station reproduces it exactly. These six steps ought to be equal in duration of time ; if it were otherwise a signal would be badly observed by the two stations corresponding. We also remedy inequalities of strength and of agility, in the operators, by directing that there must never be a change of a signal carried, before the station to which it is communicated has also carried it.

Suppose a passage of 3 signals a minute, the different steps ought to be thus divided : for observing, 4 seconds ; forming on the oblique, 4 seconds ; observing the carrying, and carrying,

4 seconds; recording, 4 seconds; and verifying with the next station, 4 seconds: total, 20 seconds.

This rapidity of three signals a minute is far from being constant. It can only be depended upon when the weather is fine, when the operators are well disposed, experienced, and faithful.

Chappé said, that when the weather was fine, and the fogs and haziness of the atmosphere are not a hindrance to vision, the first signal of a communication ought not to occupy more than 10 or 12 minutes in passing from Toulon to Paris, cities situated 215 leagues or 475 miles apart, and connected by a telegraph line of 120 stations; but Chappé added, that if we suppose a continuous correspondence between Paris and Toulon, there would ordinarily arrive at Toulon but one signal a minute.

To recapitulate, the Chappé telegraph gives 98 primitive signals for the correspondence, and 98 primitive regulating and indicating signals. These two classes of signals, although alike, must not be confounded, because they are formed one on the left oblique, and the other on the right oblique; and because they are recorded one in the regulation column, and the other in the column of correspondence. This record I have arranged in the following form, viz.:

No. of Signals.	REGULATIONS AND OFFICE SIGNALS.		SIGNALS OF CORRESPONDENCE.	
	Right Oblique.	Left Oblique.	Right Oblique.	Left Oblique.
	<i>How Carried.</i>	<i>How Carried.</i>	<i>How Carried.</i>	<i>How Carried.</i>

These signals may succeed each other with the rapidity of 3 per minute. They form figures easy to observe, easy to record, and without an effort of the mind; the machine is solid, light, and elegant. A man of moderate intelligence is entirely competent to manage the correspondence.

To show the immense superiority of the Chappé telegraph over all other aerial telegraphs which have been devised or temporarily established, either before or since his time, it would be sufficient to describe them and notice their resources; and

we shall see that none of them, if we except the Swedish telegraph invented by Edelerantz, can be said to have subserved the purposes of science or telegraphic art. In France, where the most perfect model has been before their eyes, all efforts made previous to the time of Chappé were but rude approaches to the Chappé system, and but one of those efforts still in existence. The system of Chappé produced, as a first and inevitable result, a diminution of just one third in rapidity of the signals. By analyzing its movements it is easy to anticipate such a result; but it is more easy to be convinced of it by taking such a position as to have a view of the towers of St. Sulpice. Upon one of these towers is the Chappé telegraph, and upon the other, the telegraph devised by Mr. Flocon, the third administrator of the telegraph. By watching these two telegraphs for an hour, and counting exactly the number of the signals, it will be seen that the Chappé telegraph gives exactly three signals, while the other gives two. A second objection to Mr. Flocon's telegraph is, that it requires a greater degree of intelligence to operate it; consequently it is more liable to fault in transmitting correspondence and in recording them. The regulator is placed upon a vertical mast or post, and the indicators are attached to the extremities of a fixed horizontal bar; all the signals are therefore given horizontally. We must observe the regulator separately, in order to know if we understand whether the signals belong to the right oblique or to the left oblique, and we must record them vertically or horizontally. If they are to be recorded vertically, we must then make an abstract of what we have seen, and after arranging the figure in the head, then make a draft of it. The telegraph, modified by Mr. Flocon, nevertheless offers one advantage, that of being less difficult to operate when the wind is light; but, it is said that it is not by means of new machines, or retrenchments, or additions to them, as perfected by Chappé, that the aerial telegraphing can be improved. The true and only way of progress in semaphore telegraphing is to find the means of multiplying the number of primitive signals; to combine these signals in such a way as to express, with the least motion and in the shortest time possible, the greatest quantity of numbers; to represent by these numbers as many ideas as possible, and to double the period of correspondence by continuing it through the night.

The greatest effort and the most active inventive talent have been thwarted in every effort to make an aerial telegraph effective at night, and even Chappé admitted its impracticability after the most arduous labors to consummate the object. Like

result has followed the labors of others down to the present time.

“We may at present,” says Mr. Jules Guyot, from whom much of this description has been copied, “without changing anything in the exactitude of the signals, and without changing anything in the mechanism that produces them, double their number. We may raise them to 82,944 words; parts of, or the whole of phrases, by two signals expressed by 4, 5 and 6 movements; and we may devise plans to establish the Chappé telegraph by night as it is by day. Thus the resources of the telegraphic art are far from being exhausted, and to accomplish these ends the inventive mind can be directed.”

CHAPTER IV.

The Prussian Semaphore Telegraph—The English Semaphore—The Gonon, Chappé, Guyot, and Treutler's Improvements on the Chappé Telegraph.

THE PRUSSIAN SEMAPHORE TELEGRAPH.

Fig. 1.

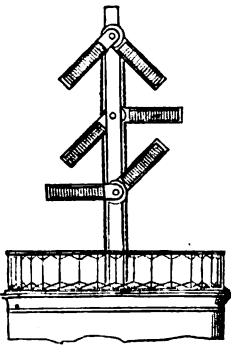

THE Prussian telegraph, represented by fig. 1, was introduced into Prussia in the year 1832, when the government appropriated 170,000 thalers for the establishment of a line of stations between Berlin and Trèves, passing through Potsdam, Magdeburg, Cologne, and Coblenz. The mechanism of the apparatus differs essentially from that of the Chappé. A vertical post traverses the platform of the station, and rises to the height of 20 feet. The post bears three pairs or couples of wings moveable around their extremities. The wings are 4 feet long, and $1\frac{1}{4}$ feet wide. Each wing is fixed to a pulley, over which passes a cord. This cord, in the room of the station-master, passes around a second pulley, to which a handle is attached. The rotation of the handle causes each wing to describe a semi-circle; but only four of these positions are used, those which the wing forms with the vertical angles 0° , 45° , 90° , and 135° . While one of the upper wings remains in the same position, the second wing may take four different positions, so that each pair of wings furnishes 16 signals. One of these signals being given, the second or middle pair of wings may, in their turn, take 16 relatively different positions, and consequently the first two wings give together $16 \times 16 = 256$ signals. This product multiplied by the sixteen signals of the third pair, gives a total of 4,096. Such is the number of signals at command by the Prussian telegraph.

The Prussian telegraph was perfected and extended over the kingdom with a degree of enterprise highly commendable to the nation. Experts were called into the service, and nowhere could be found a system more admirably conducted. Wherever improvements could be made, they were promptly adopted, and, at an early day after the establishment of the semaphore in Prussia, it was materially simplified.

THE ENGLISH SEMAPHORE TELEGRAPH.

Fig. 2.

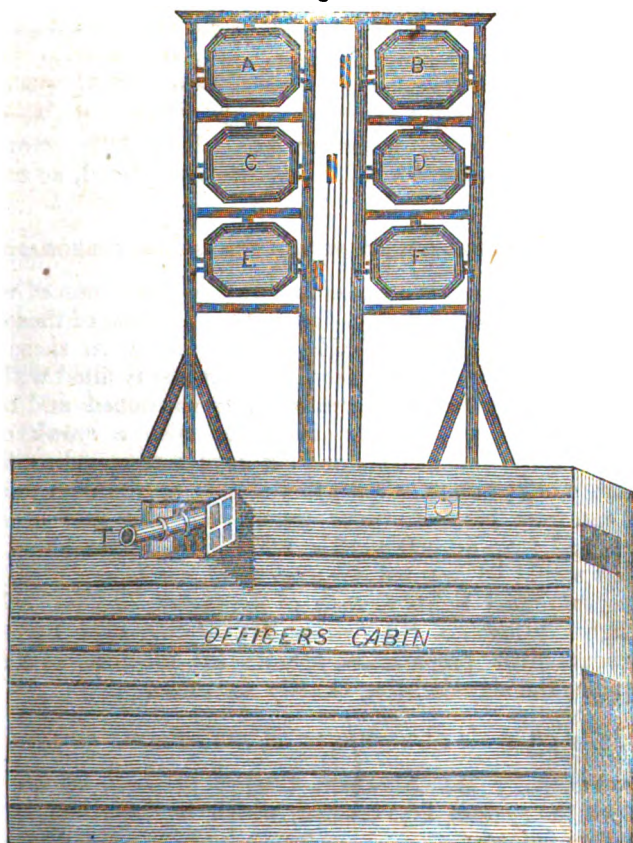

English Telegraph Station.

The English telegraph is represented in fig. 2. It consists of a quadrangular frame, in which six octagonal plates or panels turn around a horizontal axis. These six panels are divided into two groups, each formed of three plates, placed vertically above each other. A simple mechanism of pulleys and cranks enables the operator to exhibit each pan-

Fig. 3.

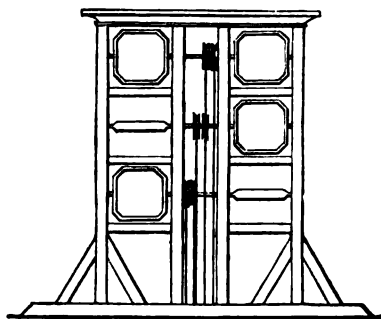

nel either its face or edge, and as each panel takes two different positions the whole will give 64 very distinct signals. This telegraph was introduced into England in 1795, and has performed much valuable service for the government and commerce. In searching for facts upon this subject in the British Museum in London, some years since, I found the above drawings. They represent their erection close to the earth, as was the case some half a century ago. High hills were then chosen, and upon them a rude structure was placed, as seen in fig. 2.

THE GONON IMPROVEMENT OF THE SEMAPHORE TELEGRAPH.

This improvement is composed of two columns, one of which is 33 feet, and the other 28 feet high. To each of these two columns are fitted two moveable arrows. Between these four arrows the distance is nine feet, which space is filled with six windows or openings, arranged so as to be opened and closed at pleasure. There are four dial plates with a crank corresponding to the four arrows, and six keys corresponding to the six sashes or openings. With this simple mechanism the operator can from his room move the arrows, shut and open the sashes, and form 40,960 signals, which Mr. Gonon found was all that would be wanted for a general correspondence. By adding two fixed lights to each of the sashes, and two moveable lights to each of the arrows, Mr. Gonon said he could, after some little preparation, operate his machine as a night telegraph, the signals being exactly the same.

ABRAHAM CHAPPE'S IMPROVEMENT ON THE ORIGINAL SEMAPHORE.

More recently Mr. Abraham Chappé proposed an improvement on the system first erected, which he described in substance, as follows :

Fig. 4.  Fig. 5.  "In my new system of numeration and combination of signals, all the official signals are given on the horizontal line as represented in fig. 4. During the entire dispatch the indicator alone moves. Each indicator, in describing its circle, stops as heretofore described at the six positions, marked in fig. 4, that is, 5, 10, and 15 sky ; 5,

Fig. 6. 

10, and 15 earth. Each angle of fig. 5, of an indicator, signifies a single number, and each corresponding angle of the opposite indicator represents the same number. The closed alone represent nothing.

"Inclosing the left indicator and opening successively the right indicator under its six angles, I shall have in the same order the number 1, 2, 3, 4, 5, and 6, by the signals represented in fig. 5. In developing both indicators at once, I shall obtain 36 combinations of two figures each, as seen in fig. 6. The numbers given by these 36 combinations are 216 series, and combining signals sufficient to represent 58,190 more than was used by the older system."

GUYOT'S IMPROVEMENT OF THE SEMAPHORE TELEGRAPH.

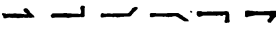
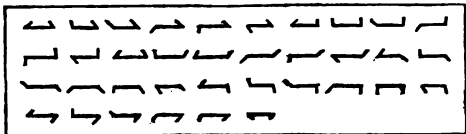
Mr. Jules Guyot proposed an improvement which is thus described. At distances of two to three miles a post was fixed about 30 feet high, strongly fastened at the foot. The upper extremities were stayed by guys of four iron cords. A station-house, some eight feet square at the foot, was erected for manipulating. The posts were fitted with ladder pins, by which they could be ascended at pleasure. Each pole, or mast, bore near its upper end a fixed axis parallel to the line, upon which a needle or indicator turned in a vertical plane. Fifteen feet lower was a second and a similar axis and indicator, and between these two axes was a moveable piece or regulator which could raise as high as the upper axis, or descend to the lower one.

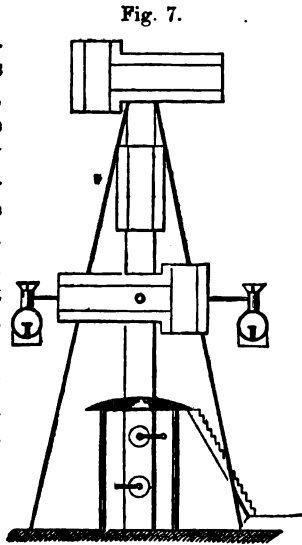
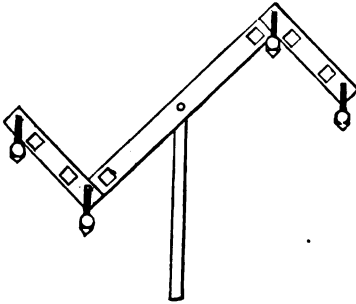

Fig. 7.

They were about nine feet long, and about three feet wide at the smaller end, and about four feet at the widest end. They were constructed with slats as the window blind, painted a heavy black through the centre, and white on the lateral bands. This ingenious contrivance of Mr. Guyot's was never practically established, but it unquestionably possessed very great merit.

The night telegraph, proposed by Mr. Guyot, was constructed with two liquid hydrogen lanterns, suspended at the

Fig. 8.



lower indicator of the day telegraph, so as to give a light in both directions. He also proposed to use lanterns on the Chappé telegraph, by placing two white lights at each extremity of the regulator, and two bright green lights at the extremity of the indicators. By means of an arrangement of these lights the Chappé telegraph was made to serve for the night. Fig. 8 represents

the signals on the right oblique indicating signals 10 earth, and 10 sky, and in which all the lanterns are outside of the mechanism, illustrating the day telegraph transformed into the night.

Fig. 9.

THE TREUTLER IMPROVEMENT IN SEMAPHORE TELEGRAPHING.

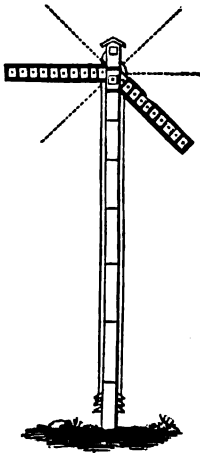

Mr. Treutler, of Berlin, constructed a semaphore telegraph to be used principally in the railway service. Fig. 9 represents the whole mechanism invented by him. It was a mast with a single pair of wings. These moveable wings were furnished with two series of mirrors as represented in fig. 10, designed to reflect the parallel to the line, and in two opposite directions.

Fig. 10.

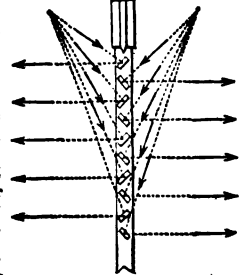

STATIC ELECTRICITY.

CHAPTER V.

Static Electricity Explained—Conductors and Non-Conductors—Vitreous and Resinous Electricity—Discovery of the Leyden Jar—Franklin's Electrical Theories—Coulomb's Theories of Electro-Statics—Franklin's Reasons for believing that Lightning and Electricity were Identical—Identity of Lightning and Electricity Demonstrated—The Franklin Kite Experiment—Distribution of Electricity—Phenomena of Resistance to Induction—Phenomena of Attraction and Repulsion—Igniting Gas with the Finger—The Leyden Jar Experiments.

STATIC ELECTRICITY EXPLAINED.

THE name, *electricity*, is derived from the Greek word *ἤλεκτρον*, which signifies *amber*, the first substance upon which, electrical properties were seen.

Since the discovery of this mysterious phenomenon in nature, the whole world has been startled from time to time, by its extraordinary developments. It was unknown to the ancients, and as a science, it dates with the eighteenth century.

I do not propose to discuss the intricacies of this science, except in general terms, and to a very limited extent. The facts herein mentioned, are from many standard works.

Static electricity is more commonly called frictional electricity. The term "static" is applied, to distinguish the action of the force excited by friction, from that excited by chemical action. Frictional, or static electricity, exhibits itself in a state of equilibrium, and remains comparatively at rest, except during the instant of discharge; while voltaic, or chemical electricity, appears to be constantly in motion, from one pole of the voltaic battery to the other, and has hence been called current electricity. Static electricity is sometimes called "electricity at rest," and voltaic, or current, is called "electricity in motion."

The subject-matter, considered in this chapter, will be "static

electricity," and in another chapter will be explained the different elements organized, to generate voltaic or "electricity in motion," as applied for telegraphic purposes.

It is supposed that electricity, in some form or other, exists in all nature, nevertheless, some substances manifest a greater degree of its presence than others.

CONDUCTORS AND NON-CONDUCTORS.

The metals were found to rank highest in this property. It has been subsequently discovered that all bodies *are conductors* of electricity more or less. No substance is at present known which is an absolutely perfect non-conductor. With all bodies, the passage through them of a *definite amount* of electricity is but a question of *time*.

The great object to be maintained in the construction of an electric telegraph is, to give the greatest possible facility for the passage of the power to a particular distant station, and to throw every possible obstacle in the way of the escape of any portion of the power in any other direction than the one desired.

For such purpose, the most perfect conductors are used for the conveyance of the power, and the most perfect insulators made to surround such conductors.

The following table exhibits the conducting power of several bodies with respect to electricity. It begins with the most perfect conductors, and ends with those which are the least perfect conductors. The properties, therefore, of these latter bodies, approximate most closely to that of non-conductors or insulators. The exact order, however, is by no means fully substantiated as yet, and the table must therefore only be taken as a general guide.

All the metals, viz. :

Silver,	Metallic ores,	Moist earths and stones,
Copper,	Animal fluids.	Powdered glass,
Gold,	Sea-water,	Flour of sulphur,
Brass,	Spring-water,	Dry metallic oxydes,
Zinc,	Rain-water,	Oils—heaviest the best,
Tin,	Ice above 13° Fahr.	Ashes, vegetable bodies,
Platinum,	Snow,	Ashes of animal bodies,
Palladium,	Living vegetables,	Many transparent crystals, dry,
Iron and	Living animals,	Ice below 13° Fahr.,
Lead,	Flame,	Phosphorus,
Well-burnt Charcoal,	Smoke,	Lime,
Plumbago,	Steam,	Dry chalk,
Concentrated acids,	Salts soluble in water,	Native carbonate of bar-rytes,
Powdered charcoal,	Rarefied air,	Lycopodium,
Dilute acids,	Vapor of alcohol,	
Saline solutions,	Vapor of ether,	

Gum elastic,	Parchment,	Mica,
Camphor,	Dry paper,	All vitrifications,
Some silicious and argil- laceous stones,	Feathers,	Glass,
Dry marble,	Hair,	Jet,
Porcelain,	Wool,	Wax,
Dry vegetable bodies,	Dyed silk,	Sulphur,
Baked wood,	Bleached silk,	Resins,
Dry gases and air,	Raw silk,	Amber,
Leather,	Transparent gems,	Shellac.
	Diamond,	

Gutta-percha, has recently been discovered, and it is found in practical service to be a better non-conductor than glass, and possibly than shellac. It has proved of wonderful utility in the art of telegraphing.

VITREOUS AND RESINOUS ELECTRICITY.

The celebrated philosopher, Dufaye, discovered that there were two distinct kinds of electricity, one of which he called *vitreous*, or that of glass, rock-crystal, precious stones, hair of animals, wool, and many other bodies; and the other *resinous*, that of amber, copal, gum-lac, silk-thread, paper, and a vast number of other substances. He showed that bodies having the same kind of electricity repel each other, but attract bodies charged with electricity of the other kind; and he proposed that test of the state of the electricity of any given substance which has ever since his time been adhered to, viz.: to charge a suspended light substance with a known species of electricity, and then to bring near it the body to be examined. If the suspended substance was repelled, the electricity of both bodies was the same; if attracted, it was different.

DISCOVERY OF THE LEYDEN JAR.

It was in the year 1746, that those celebrated experiments, which drew for many succeeding years the almost exclusive attention of men of science to the new subject, and which led the way to the introduction of the Leyden vial—were made by Muschenbroek, Cuneus, and Kleist. Professor Muschenbroek and his associates, having observed, that electrified bodies, exposed to the atmosphere, speedily lost their electric virtue, conceived the idea of surrounding them with an insulating substance, by which they thought that their electric power might be preserved for a longer time. Water contained in a glass bottle was accordingly electrified, but no remarkable results were obtained, till one of the party, who was holding the bottle, attempted to disengage the wire communicating with the prime conductor of a powerful machine; the conse-

quence was, that he received a shock, which, though slight, compared with such as are now frequently taken for amusement from the Leyden vial, his fright magnified and exaggerated in an amusing manner. In describing the effect produced on himself, by taking the shock from a thin glass bowl, Muschenbroek stated in a letter to Réaumer, that "he felt himself struck in his arms, shoulders, and breast, so that he lost his breath, and was two days before he recovered from the effects of the blow and the terror," adding, "he would not take a second shock for the kingdom of France." M. Allamand, on taking a shock, declared, "that he lost the use of his breath for some minutes, and then felt so intense a pain along his right arm, that he feared permanent injury from it." Winkler stated, that the first time he underwent the experiment, "he suffered great convulsions through his body; that it put his blood into agitation; that he feared an ardent fever, and was obliged to have recourse to cooling medicines!" The lady of this professor took the shock twice, and was rendered so weak by it, that she could hardly walk. The third time it gave her bleeding at the nose. Such was the alarm with which these early electricians were struck, by a sensation which thousands have since experienced in a much more powerful manner, without the slightest inconvenience. It serves to show how cautious we should be in receiving the first accounts of extraordinary discoveries, where the imagination is likely to be affected.

After the first feelings of astonishment were somewhat abated, the circumstances which influenced the force of the shock were examined. Muschenbroek observed that the success of the experiment was impaired if the glass was wet on the outer surface. Dr. Watson showed, that the shock might be transmitted through the bodies of several men touching each other, and that the force of the charge depended on the extent of the external surface of the glass in contact with the hand of the operator. Dr. Bevis proved that tin-foil might be substituted successfully for the hand outside, and for the water inside the jar; he coated panes of glass in this way, and found that they would receive and retain a charge; and lastly, Dr. Watson coated large jars inside and outside with tin-foil, and thus constructed what is now known as the Leyden vial.

FRANKLIN'S ELECTRICAL THEORIES.

It was in the year 1747, that, in consequence of a communication from Mr. Peter Collinson, a Fellow of the Royal Society of London, to the Literary Society of Philadelphia, Franklin first directed his attention to electricity; and from that period,

till 1754, his experiments and observations were embodied in a series of letters, which were afterward collected and published. "Nothing," says Priestley, "was ever written upon the subject of electricity, which was more generally read and admired in all parts of Europe, than these letters. It is not easy to say, whether we are most pleased with the simplicity and perspicuity with which they are written, the modesty with which the author proposes every hypothesis of his own, or the noble frankness with which he relates his mistakes when they were corrected by subsequent experiments." The opinion adopted by Franklin with respect to the nature of electricity differed from that previously submitted by Dufaye. His hypothesis was as follows: "All bodies in their natural state are charged with a certain quantity of electricity, in each body this quantity being of definite amount. This quantity of electricity is maintained in equilibrium upon the body by an attraction which the particles of the body have for it, and does not therefore exert any attraction for other bodies. But a body may be invested with more or less electricity than satisfies its attraction. If it possesses more, it is ready to give up the surplus to any body which has less, or to share it with any body in its natural state; if it have less, it is ready to take from any body in its natural state a part of its electricity, so that each will have less than its natural amount. A body having more than its natural quantity is electrified *positively* or *plus*, and one which has less is electrified *negatively* or *minus*. One electric fluid is thus supposed to exist, and all electrical phenomena are referable either to its accumulation in bodies in quantities more than their natural share, or to its being withdrawn from them, so as to leave them *minus* their proper portion. Electrical excess then represents the vitreous, and electrical deficiency the resinous electricities of Dufaye: and hence the terms *positive* and *negative*, for *vitreous* and *resinous*." The application of this theory to the explanation of the Leyden vial will appear in its proper place.

Besides this theory, we are indebted to Franklin for the discovery of the identity of lightning and electricity, for the invention of paratonnerres, and for the discovery of induction, which latter principle was immediately taken up, and pursued through its consequences by Wilke and Æpinus, and soon led to the invention of an instrument, which in the hands of Volta, became the *condenser*, now so useful in electroscopical investigations.

Franklin's hypothesis was investigated mathematically by Æpinus and Mr. Cavendish, between the years 1759 and 1771.

About the same time the electrophorus was constructed by Volta; Watson and Canton fused metals by electricity, and Beccaria decomposed water, although at the time he had no idea he had done so, supposing it to be a simple elementary substance.

COULOMB'S THEORIES OF ELECTRO-STATICS.

In the year 1785, the foundation of *electro-statics* was laid by Coulomb, a most profound philosopher, who reduced electricity, the most subtle of all physical agents, to the rigorous sway of mathematics, and caused it to become a branch of mathematical physics. By means of his torsion electrical balance, he made three valuable additions to the science; establishing—1st, That electrical forces, viz., attraction and repulsion, vary *inversely as the square of their distances*, following, it will be observed, the same law as gravitation;—2d, That excited bodies, when insulated, gradually lose their electricity free from two causes; from the surrounding atmosphere being never free from conducting particles, and from the incapacity of the best insulators to retain the whole quantity of electricity with which any body may be charged, there being no substance known altogether impervious to electricity—Coulomb determined the effect of both these causes;—3d, That when electricity is accumulated in any body, the whole of it is deposited on the surface, and none penetrates to the interior. A thin hollow sphere may contain precisely as much electricity as a solid of the same size. Hence, accumulation is not a consequence of attraction for mass of matter, but on the contrary, is solely due to its repulsive action. These observations of Coulomb on the distribution of the electric fluid on the surfaces of conductors, illustrated satisfactorily the doctrine of points which formed so prominent a part of Franklin's researches.

FRANKLIN'S REASONS FOR BELIEVING THAT LIGHTNING AND ELECTRICITY WERE IDENTICAL.

It was in the year 1749, that the celebrated American philosopher, Franklin, in a letter to Mr. Collinson, stated fully his reasons for considering the cause of electricity and lightning to be the same physical agent, differing in nothing, save the intensity of its action. "When," says he, "a gun-barrel, in electrical experiments, has but little electrical fire in it, you must approach it very near with your knuckle before you can draw a spark; give it more fire and it will give a spark at a greater distance. Two gun-barrels united, and as highly electrified, will give a spark at a still greater distance. But if two gun-barrels electrified will strike at two inches distance, and

make a loud snap, to what a great distance may ten thousand acres of electrified cloud strike, and give its fire, and how loud must be that crack ?” He next states the analogies which afford presumptive evidence of the identity of lightning and electricity. The electrical spark is zig-zag, and not straight; so is lightning. Pointed bodies attract electricity; lightning strikes mountains, trees, spires, masts, and chimneys. When different paths are offered to the escape of electricity, it chooses the best conductor; so does lightning. Electricity fires combustibles: so does lightning. Electricity fuses metals: so does lightning. Lightning rends bad conductors when it strikes them; so does electricity when rendered sufficiently strong. Lightning reverses the poles of a magnet; Electricity has the same effect. A stroke of lightning when it does not kill, often produces blindness. Lightning destroys animal life, and so do electrical shocks.

In his memorandum-book of November 7th, 1749, Franklin wrote the following reasons, which induced him to believe, that the lightning and electricity were identical :

“ Electric fluid agrees with lightning in these particulars: 1, giving light; 2, color of the light; 3, crooked direction; 4, swift motion; 5, being conducted by metals; 10, melting metals; 11, firing inflammable substances; 12, sulphurous smell. The electric fluid is attracted by points. We do not know whether this property is in lightning, but since they agree in all the particulars in which we can already compare them, is it not probable they agree likewise in this? Let the experiment be made.”

From the effect of points on electrified bodies, Franklin inferred that lightning might also be drawn silently and safely from the clouds, by a metallic point fixed at a great elevation, and he waited with considerable anxiety the completion of a spire at Philadelphia, to enable him to try the experiment. In the meantime, he published his discoveries, and suggested to others to make the necessary experiment.

He published to the world the following plan :

“ To determine this question, whether the clouds that contain lightning be electrified or not, I would propose an experiment to be tried, where it may be done conveniently. On the top of some high tower or steeple, place a kind of sentry-box, big enough to contain a man and an electrical stand. From the middle of the stand let an iron rod rise, and pass, bending out of the door, and then upright twenty or thirty feet, pointed very sharp at the end. If the electrical stand be kept clear and dry, a man standing on it, when such clouds are passing low, might be electrified, and afford sparks, the rod drawing

fire to him from a cloud. If any danger to the man be apprehended, let him stand on the floor of his box, and now and then bring near to the rod the loop of a wire that has one end fastened to the leads, he holding it by a wax handle; so the sparks, if the rod is electrified, will strike from the rod to the wire, and not affect him."

IDENTITY OF LIGHTNING AND ELECTRICITY DEMONSTRATED.

In accordance with the above suggestions, two Frenchmen, M. Dalibard and M. Delor, each erected an apparatus for the purpose of drawing from the clouds the lightning. M. Dalibard constructed his at Marly-la-ville, about six leagues from Paris, and M. Delor had his on a high part of Paris.

M. Dalibard's apparatus consisted of an iron pointed rod, forty feet long, the lower end of which was inserted in a sentry-box, protected from rain, and on the outside it was fastened to three wooden posts by silk cords, also defended from the rain. It was this rod that first attracted electricity from the clouds. M. Dalibard was absent from Marly at the time, and had left the apparatus in charge of an old soldier, named Coiffier, who was at the time engaged as a carpenter. On the 10th of May, 1752, between two and three o'clock in the afternoon, a sudden clap of thunder made Coiffier hurry to his post, and, according to the instructions given him, he presented a vial furnished with a brass wire to the rod, and immediately saw a bright spark, accompanied by a loud snapping noise. After having taken another spark stronger than the first, he called in the neighbors, and sent for the curé. The latter ran to the spot with all speed, and his parishioners seeing him running, followed at his heels, expecting that Coiffier had been killed by lightning; nor were they prevented from hastening to the spot, notwithstanding a violent hail-storm. The curé was equally successful in drawing sparks from the iron rod, and instantly dispatched an account of the important event to M. Dalibard. The curé stated that the sparks were of a blue color, an inch and a half long, and smelt strongly of sulphur. He drew sparks at least six times in about four minutes, and in the course of these experiments he received a shock in the arm, extending above the elbow, which he said left a mark, such as might have been made by a blow with the wire on the naked skin.

Eight days after this experiment, the rod erected by M. Delor, which was ninety-nine feet high, yielded electric sparks; and the same phenomenon was afterward exhibited to the French king, and to members of the nobility.

Fig. 1.



THE FRANKLIN KITE EXPERIMENT.

The experiment made by Franklin was in June, 1752; the description of which will be found in the following :

Fig. 2.



“ He prepared his kite by making a small cross of two light strips of cedar, the arms of sufficient length to extend to the four corners of a large silk handkerchief stretched upon them; to the extremities of the arms of the cross he tied the corners of the handkerchief. This being properly supplied with a tail, loop, and string, could be raised in the air like a common paper kite; and being made of silk, was more capable of bearing rain and wind. To the upright arm of the cross was attached an iron point, the lower end of which was in contact with the string by which the kite was raised, which was a hempen cord. At the lower extremity of this cord, near the observer, a key was fastened: and in order to intercept the electricity in its descent, and prevent it from reaching the person who held the kite, a silk ribbon was tied to the ring of the key, and continued to the hand by which the kite was held.

Furnished with this apparatus, on the approach of a storm, he went out upon the commons near Philadelphia, accompanied by his son, to whom alone he communicated his intentions, well knowing the ridicule which would have attended the report of such an attempt should it prove to be unsuccessful. Having raised the kite, he placed himself under a shed, that the ribbon by which it was held might be kept dry, as it would

become a conductor of electricity when wetted by rain, and so fail to afford that protection for which it was provided. A cloud, apparently charged with thunder, soon passed directly over the kite. He observed the hempen cord; but no bristling of its fibres was apparent, such, as was wont to take place when it was electrified. He presented his knuckle to the key, but not the smallest spark was perceptible. The agony of his expectation and suspense can be adequately felt by those only who have entered into the spirit of such experimental researches. After the lapse of some time, he saw that the fibres of the cord near the key bristled, and stood on end. He presented his knuckle to the key and received a strong bright spark. *It was lightning.* The discovery was complete, and Franklin felt that he was immortal.

A shower now fell, and wetting the cord of the kite improved its conducting power. Sparks in rapid succession were drawn from the key; a Leyden jar was charged by it, and a shock given: and, in fine, all the experiments which were wont to be made by electricity were reproduced, identical in all their concomitant circumstances."

Franklin afterward raised an insulated metallic rod from one end of his house, and attached to it a chime of bells, which, by ringing, gave notice of the electrical state of the apparatus.

These interesting experiments were eagerly repeated in almost every civilized country, with variable success. In France, a grand result was obtained by M. de Romas: he constructed a kite seven feet high, which he raised to the height of 550 feet by a string, having a fine wire interwoven through its whole length. On the 26th of August, 1756, flashes of fire, ten feet long, and an inch in diameter, were given off from the conductor. In the year 1753, a fatal catastrophe from incautious experiments upon atmospheric electricity, occurred to Professor Richmann, of St. Petersburg; he had erected an apparatus in the air, making a metallic communication between it and his study, where he provided means for repeating Franklin's experiments: while engaged in describing to his engraver, Sokoloff, the nature of the apparatus, a thunder-clap was heard, louder and more violent than any which had been remembered at St. Petersburg. Richmann stooped toward the electrometer to observe the force of the electricity, and "as he stood in that posture, a great white and bluish fire appeared between the rod of the electrometer and his head. At the same time a sort of steam or vapor arose, which entirely benumbed the engraver,

and made him sink on the ground." Several parts of the apparatus were broken in pieces and scattered about: the doors of the room were torn from their hinges, and the house shaken in every part. The wife of the professor, alarmed by the shock, ran to the room, and found her husband sitting on a chest, which happened to be behind him when he was struck, and leaning against the wall. He appeared to have been instantly struck dead; a red spot was found on his forehead, his shoe was burst open, and a part of his waistcoat singed; Sokoloff was at the same time struck senseless. This dreadful accident was occasioned by the neglect on the part of Richmann to provide an arrangement by which the apparatus, when too strongly electrified, might discharge itself into the earth.

DESCRIPTION OF ELECTRICAL MACHINES.

I have, now, sufficiently explained to the reader the wonderful experiments of Franklin, and those in France, made in the month of May, 1752, in accordance with the plans published by him. I will proceed to notice the means of manifesting

Fig. 8.

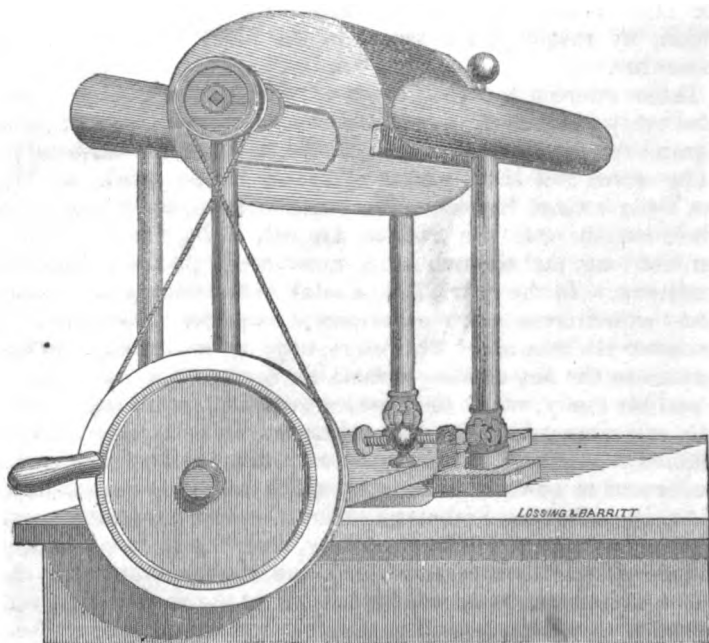

frictional electricity, commonly known as *static*, in contradistinction to that generated by chemical action. Static electricity, as I have already stated, is sometimes called "electricity at rest," and a voltaic current, is called "electricity in motion." The former remains comparatively at rest, excepting during the instant of discharge.

The following are descriptions of electrical machines, viz. : There are two kinds of electrical machines in general use—the cylindrical, and the plate machine. The former is shown in fig. 3. It consists of a hollow cylinder of glass, supported on brass bearings, which revolve in upright pieces of wood attached to a rectangular base ; a cushion of leather stuffed with horse-hair, and fixed to a pillar of glass, furnished with a screw to regulate the degree of pressure on the cylinder ; a cylinder of metal or wood covered with tin-foil, mounted on a glass stand, and terminated on one side by a series of points to draw the electricity from the glass, and on the other side by a brass ball. A flap of oiled silk is attached to the rubber to prevent the dissipation of the electricity from the surface of the cylinder before it reaches the points. On turning the cylinder, the friction of the cushion occasions the evolution of electricity, but the production is not sufficiently rapid or abundant without the aid of a more effective exciter, which experience has shown to be a metallic substance. The surface of the leather cushion is therefore smeared by certain amalgams of metals, which thus become the real rubber. The amalgam employed by Cānton, consisted of two parts of mercury, and one of tin, with the addition of a little chalk. Singer proposed a compound of two parts by weight of zinc, and one of tin, with which in a fluid state six parts by weight of mercury are mixed, and the whole shaken in an iron, or thick wooden box, until it cools. It is then reduced to a fine powder in a mortar, and mixed with lard in sufficient quantity to reduce it to the consistency of paste. This preparation should be spread cleanly over the surface of the cushion, up to the line formed by the junction of the silk flap with the cushion ; but care should be taken that the amalgam should not be extended to the silk flap. It is necessary occasionally to wipe the cushion, flap, and cylinder, to cleanse them from the dust which the electricity evolved upon the cylinder always attracts in a greater or less quantity. It is found that from this cause, a very rapid accumulation of dirt takes place on the cylinder, which appears in black spots and lines upon its surface. As this obstructs the action of the machine, it should be constantly removed.

which may be done by applying to the cylinder, as it revolves, a rag wetted with spirits of wine. The production of electricity is greatly promoted by applying, with the hand to the cylinder, a piece of soft leather, five or six inches square, covered with amalgam. This is, in fact, equivalent to giving a temporary enlargement to the cushion.

The use of the oiled silk flap is to prevent the dissipation of the electricity evolved on the glass by contact with the air; it is thus retained on the cylinder till it encounters the points of the prime conductor, by which it is rapidly drawn off. It is usual to cover with a varnish of gum lac, those parts of the glass beyond the ends of the rubber, with a view of preventing the escape of the electricity through the metallic caps at the extremities of the cylinder, and the inside of the flap is also sometimes coated with a resinous cement, consisting of four parts of Venice turpentine, one part of resin, and one of bees' wax, boiled together for about two hours in an earthen pipkin over a slow fire.

Fig. 4.

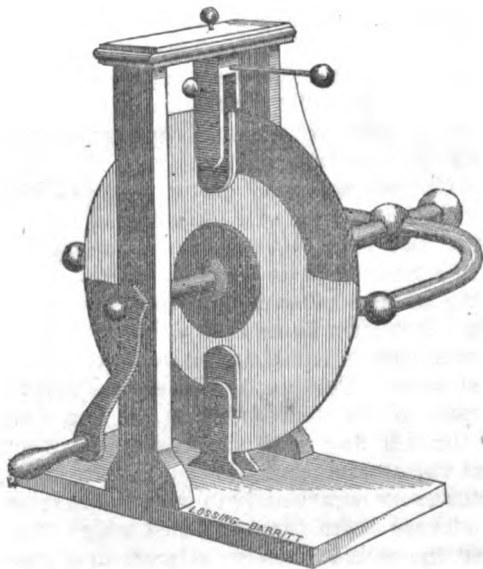

When the cylindrical machine is arranged for the development of either positive or negative electricity, the conductor is placed with its length parallel to the cylinder, and the points

project from its side, as in the machine shown in the figure. The *negative* conductor supports the rubber, and receives from it the negative electricity, not by induction, as is the case with the positive conductor, but by *communication*. If it be required to accumulate positive electricity, a chain must be carried from the negative conductor (which of course is insulated) to the ground. If on the other hand, negative electricity be required, then the conductor must be put in communication with the earth, and the rubber insulated.

The plate electrical machine is shown in fig. 4. It consists of a circular plate of thick glass, revolving vertically by means of a winch between two uprights: two pairs of rubbers, formed of slips of elastic wood, covered with leather, and furnished with silk flaps, are placed at two equi-distant portions of the plate, on which their pressure may be increased or diminished by means of brass screws. The prime conductor consists of hollow brass, supported horizontally from one of the uprights; its arms, where they approach the plate, being furnished with points.

With respect to the merits of these two forms of the electrical machine, it is difficult to decide to which to give the preference. For an equal surface of glass, the plate appears to be the most powerful; it is not, however, so easily arranged for negative electricity, in consequence of the uninsulated state of the rubbers, though several ingenious methods of obviating this inconvenience have been lately devised.

DISTRIBUTION OF ELECTRICITY.

When a substance becomes charged with electricity, it is extremely probable, in the opinion of philosophers, that the fluid is confined to its surface, or, at any rate, that it does not penetrate

into the mass to any extent. This is a question difficult to demonstrate, and my observations have induced me to believe, that in the case of voltaic currents the electricity moves upon or at the surface, but that the interior of the metallic conductor is under the influence of the fluid, though in a state of rest.

Experiments have been made with static or frictional electricity by Biot, and the following facts were arrived at: A ball

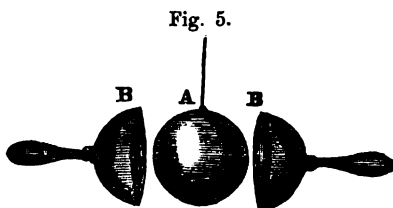

formed of any kind of material, will be equally electrified whether it be solid or hollow, and if it be hollow, the charge which it receives will be the same whether the shell of matter of which it is formed be thick or thin.

A sphere of conducting matter, Λ , is insulated by a silk thread, and two thin hollow hemispheres, $B B$, made of metallic foil or gilt paper, and provided with glass handles, corresponding with the shape and magnitude of the conductor. The sphere Λ , is electrified, and the covers are then applied, being held by the glass handles. After withdrawing them from Λ , they are found to be charged with the same kind of electricity as was communicated to Λ , and the ball will be found to have lost the whole of its charge, proving that the electricity resided on the surface only.

Fig 6.

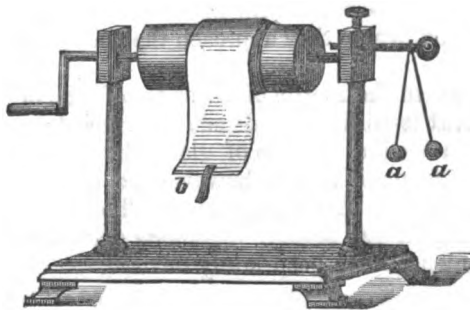

To further demonstrate that the electricity holds its position on the surface, fig. 6 is to illustrate. At the ends of the cylinder, are attached an electroscope, composed of two elder-pith balls, suspended to linen threads. The whole is to be electrified, and the pith-balls, $a a$, will diverge as seen in the figure. In this state take hold of the silken thread at b , and then unroll the metallic ribbon b . When it is unrolled, the pith-balls will come into or near a contact. Replace the ribbon, and the balls diverge again. When the metallic ribbon is taken off, it carries from the cylinder the whole of the electric charge. The outer layer of the metallic ribbon, when around the cylinder, is charged plus, as compared with the inner layer, but as soon as the ribbon has been taken from its circular position, the electricity immediately distributes itself equally throughout the ribbon's surface. Restore the ribbon around the cylinder, and the plus will be found on the exterior surface.

Figure 7 is another illustration of the diffusion of electricity on the outside of vessels. This is a cylinder made of wire-gauze. Let the insulated *b* be lowered into a wire-gauze cylinder, *A*, fig. 7, when electrified and mounted on an insulating stand. It may touch every part of the interior without receiving any portion of the electricity, with which the exterior surface is charged, though the slightest touch on the other side of the open wire mesh communicates electricity to the ball.

I am fully sensible of the fact, that this important principle in philosophy has not been clearly demonstrated in the foregoing, but the room allowed in this work renders further explanations impossible, and the reader must refer to the standard works on electricity for fuller information in the premises.

Fig. 7.



PHENOMENA OF RESISTANCE TO INDUCTION.

Fig. 8.

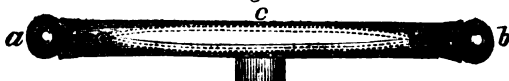
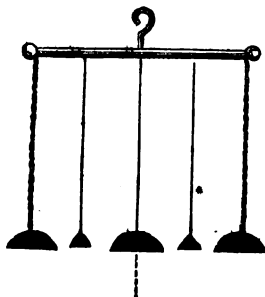

Figure 8 represents the resistance to induction and discharge offered by any given media, such as atmospheric air, &c. The glass tube, *a b*, two feet long, is furnished at either end with a brass ball projecting into its interior, and carefully exhausted of its air by means of an air-pump; on connecting the end *a*, with the prime conductor, and the end *b*, with the earth, when the machine is turned, *a* becomes positive, and induces the contrary state on the ball *b*; induction taking place with facility, in consequence of the atmospheric pressure being removed—and is followed by a discharge of the two electricities in the form of a beautiful blue flame filling the whole tube, and closely resembling the aurora borealis.

Fig. 9.

PHENOMENA OF ATTRACTION AND REPULSION.

The phenomena of attraction and repulsion are well illustrated by the apparatus known as the electric bells, fig. 9. They are suspended from the prime conductor by means of the hook; the two outer bells are suspended by brass chains, while the central, and the two clappers, hang from silken strings; the



middle bell is connected with the earth by a wire or chain; on turning the cylinder, the two outside bells, become positively electrified, and by induction the central one becomes negative, a luminous discharge taking place between them, if the electricity be in too high a state of tension. But if the cylinder be slowly revolved, the little brass clappers will become alternately attracted and repelled by the outermost and inner bells, producing a constant ringing as long as the machine is worked.

Fig. 10.



Another experiment is often given with the toy-head. When attached to the prime conductor of the machine, the hairs stand erect, presenting an exaggerated representation of fright, as seen by fig. 10.

Figure 11 represents an experiment with the dancing toys. A brass plate is suspended from the prime conductor, and under it is placed a sliding stand, on which is laid a little bran or sand, or little figures made of pith: on turning the machine, the bran, or sand, or figure is attracted and repelled by the upper plate with such rapidity, that the motion is almost imperceptible, and appears like a white cloud between the plates, and the little figures appear to be animated, dance, and exhibit very singular motions, dependent on inductive action.

Fig. 11.

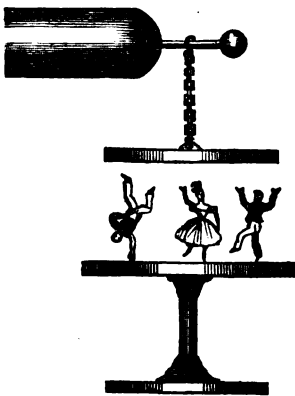
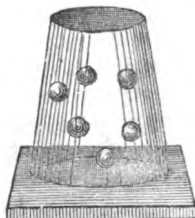

Figure 12, represents an inverted tumbler, wiped thoroughly dry, warmed, and the inside charged by holding it in such a direction that a wire proceeding from the prime conductor of a machine in action, shall touch it nearly in every part; then invert it over a number of pith-balls; they will be attracted and repelled backward and forward, and effect the discharge of the electricity which induces from the interior toward the plate. They will then remain at rest; but, if the electricity which has been disengaged on the outside, toward surrounding objects be removed by a touch of the hand, a fresh portion will be set free on the

interior, and the attraction and repulsion of the balls will again take place, and thus for many times successively the action will be renewed until the glass returns to its natural state.

Fig. 12.



IGNITING GAS WITH THE FINGER.

A very interesting experiment is represented by figure 13, showing the lighting of gas with an electric spark from the finger. In my apartments, it has been the mischievous practice of my son, to pass several times around a room, rubbing or sliding his shoes on the carpet, charging his body with electricity, in the same manner as produced by the machine. The body being fully electrified in

Fig. 13.

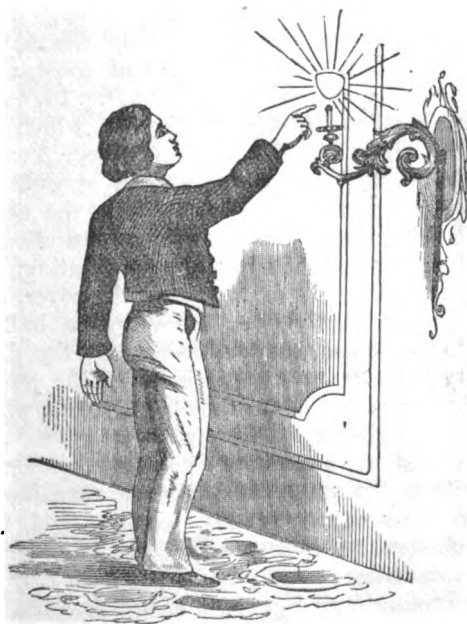

this manner, he would point his finger within a few inches of the nose of some one present; the spark would pass with a noise from the finger to the nose, giving the recipient a sensible shock, unpleasant to the nose, but amusing to others present.

In this manner he frequently lighted the gas. It is a very simple amusement, and any one can, in like manner, at their own homes perform the experiment. The room must be warm, the carpet must have a nap, and the shoes must be perfectly dry.

THE LEYDEN JAR EXPERIMENTS.

The principles of the Leyden jar have become more or less interesting to the telegrapher, particularly with reference to submarine and subterranean lines. The following, from Bakewell, contains a concise description of the principles of this important apparatus. It is called a Leyden jar because it was first constructed by Muschenbroek and his friends, at Leyden, Holland, in the year 1746.

“The power of accumulating electricity by means of the Leyden jar has placed in the hands of electricians a force of almost unlimited extent. In our sketch of the history of electric science, we have already adverted to the nature of the apparatus. As at present constructed, it consists of a thin glass jar *A*, fig. 14, coated within and without with tin-foil, which reaches to about three inches from the top. A wooden cover, *B*, serves as a support to a straight thick brass wire, *c*, that passes through the centre of the cover, and has a metallic connection by a chain or wire with the interior coating. This wire rises a few inches above the cover, and is surmounted by a hollow brass ball, which is

Fig. 14.



screwed on to the top of the wire to prevent the dispersion of the electricity from the end. The sizes of the jars vary from half a pint to ten gallons. One holding about a pint will give a shock as strong as most persons like to receive.

To charge a jar with positive electricity, connect its small brass ball with the prime conductor of the machine, and make a connection between the outside coating and the ground. When fully charged it will give indications of its electrical condition by a muttering sound; and in the dark, rays of light will be seen issuing from the edges of the tin-foil and from the ball. The notion of Muschenbroek, which led to the discovery of the Leyden jar, was to collect electricity within a phial to prevent its dispersion, and thereby to store up an increased quantity of the electric fluid; but it is now ascertained that a jar when highly charged does not contain more electricity than it did before it was applied to the conductor. The effect pro-

duced by charging is not to increase the quantity, but only to disturb the natural electricity previously present in a latent state on the inside and outside of the glass. There is injected into the inside, by connection with the electrical machine, an amount of positive electricity, while an equal amount of negative electricity is driven from the outside by the force of electrical induction; and unless the electricity on the outer surface of the glass can be thus driven off by affording it a connection with the ground, the inside cannot receive a charge.

Let a Leyden jar be insulated from the earth by placing it on a glass stand, and it will receive scarcely any electricity from the conductor; not more than equal to the quantity which can escape from the outside to the surrounding air. If the knob of another insulated jar be connected with the ground, and the outside coatings of the two jars be brought near together, sparks will then pass rapidly from the prime conductor to the knob of the first, and they will also pass as rapidly between the outside coatings of the two jars. In this manner both the Leyden jars become charged, and it will be found that they are charged equally, but with electricity of opposite kinds. The first one, that derived its electricity directly from the prime conductor, will be charged positively; the second, that derived its charge from the electricity escaping from the knob to the ground, will be negative. Place the two jars on the table, and suspend between them a pith ball, *B*, or other light substance, and it will be attracted alternately from one to the other in rapid vibrations, clearly showing that the electricity in the two jars is of opposite kinds.

The phenomena that occur during the charge of a Leyden jar have been adduced as evidence in support of the Franklinian theory of a single electric fluid, the outside being supposed to be in a *minus* state after parting with its natural quantity to the other jar. But the phenomena are explicable also on the hypothesis of two fluids, it being assumed that they are separated from their neutral state by the coercing force of the free electricity communicated to the inside of the jar.

Fig. 15.

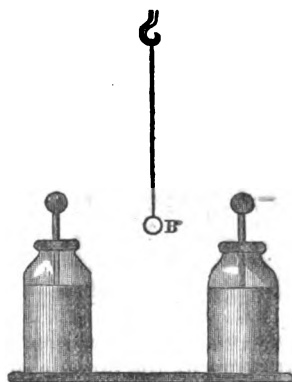

Franklin attempted to apply practically the charging of one jar from the escaping electricity of another. He inferred, that, if a series of insulated jars were arranged with the outside coatings and knobs alternately touching, the coating of the last one being connected with the ground, by this arrangement the positive electricity expelled from the outside of the first jar would charge the second; that the electricity from the outside of the second would charge the third positively, and so on to any number; and that an immense electric force might be thus accumulated from the same quantity of electricity that is required to charge a single jar.

Let *A B C* represent a series of three jars, *A* and *B* being mounted on insulating glass stands, fig. 16.

Fig. 16.

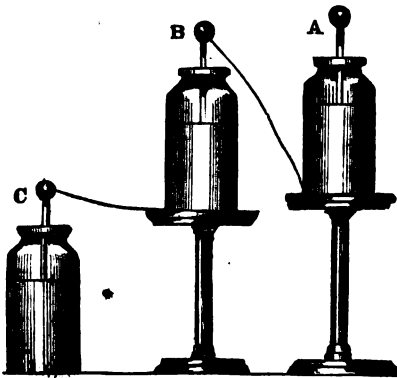

On making connection from the prime conductor of an electrical machine to the knob of *A*, that jar will be charged positively, and an equal amount of electricity will be expelled from the outside into *B*, which will also be positively charged. The third jar, *C*, will in like manner be charged from the outside of *B*, and the electricity which was expelled from *A*, on arriving at the outside of the last jar of the series, will be conducted to the earth.

To effect the discharge of a jar, it is requisite that a connection be made between the positive electricity within and the negative electricity without, so that the equilibrium may be restored. Now if a metallic connection be made from the knob of *B* to the knob of *A*, there will be a discharge of the first jar only; for though the connection is made with the knob of *B*, none of the positive electricity within can be discharged, for it is restrained by the coercing force of the opposite electricity on the outside. If metallic connection be made between the outside of *B* and the knob of *A*, both those jars will be discharged, and the third will remain charged; but by bringing a wire from the outside of *C* to the knob of *A*, the three jars will be at once discharged.

The phenomena exhibited in charging the Leyden jar has

been explained ; the cause of its accumulating electricity, and discharging the force instantaneously, will be next considered. We have stated that the cause depends on inductive action operating through the substance of the non-conducting glass. Exemplifications of this action through glass have been previously given. A pane of glass when excited by friction on one side has negative electricity induced on the other, and a glass tumbler may be charged with electricity by exposing the inside to the influence of an electrified point, while the outside is grasped by the hand. The electricity thus collected on the surfaces of the pane of glass and the tumbler is sluggish in its action, and is dissipated by slow degrees, on account of the non-conducting property of the glass surfaces ; but if metal plates be applied on each side of the pane of glass, the electricity is instantly concentrated at any point, and on connecting the two surfaces with a wire, a discharge takes place, exactly as in the Leyden jar. The charged tumbler might also be converted into a Leyden jar by the application of interior and exterior casings of metal foil, to serve as conductors, to concentrate at any point the electricity distributed over the surface of the glass.

To prove most conclusively that the charge of a Leyden jar is retained on the surface of the glass, and not in the metallic coatings, Leyden jars are made with tin inside and outside casings, so contrived that they may be easily removed. A jar of this kind, when charged and placed on an insulating stand, may have the metal casings removed and others substituted for them ; yet after this change the jar will be found to retain its charge. The metal serves only to conduct the electricity simultaneously from all parts of the glass.

A plate of glass affords the most convenient mode of illustrating that the electrical charge is retained by the glass and not by the metal. Let a pane of glass, about one foot square, be covered on one side with tin-foil, and laid horizontally on the table. To the other side apply the insulated metal disk of an electrophorus ; connect the disk with the prime conductor, and a few turns of the machine will charge the glass. Remove the disk by the insulating handle, and it will manifest scarcely any trace of electricity. Let the same or another disk be again applied to the surface of the glass, and on making connection between the metals on the opposite sides a strong discharge will take place. A moveable metal disk might be applied to each surface of the glass with similar results ; but the arrangement indicated is more convenient.

When a more powerful charge of electricity is required than

a single jar will retain, several are combined to form an electrical battery. For convenience, the jars are placed in a box with divisions, the bottom being lined with tin-foil, to make connection with all the exterior coatings. The knobs of the jars are connected together by wires, as represented in fig. 16; and there is a metal hook projecting from the side of the box connected with the tin-foil lining. Thus all the interior

Fig. 17.

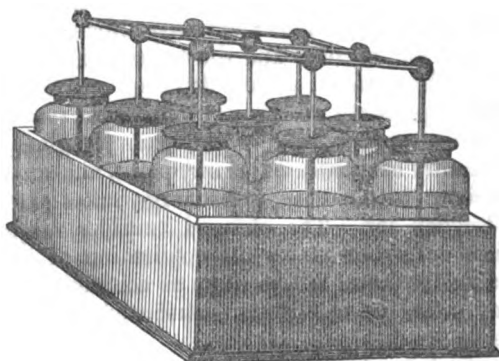

and all the outside coatings of the jars are connected; and when communication is made between the prime conductor and any of the knobs of the jars, the whole are simultaneously charged. They are also discharged simultaneously by making connection between the projecting hook and any one of the knobs.

The combination of several small jars is found better than having a smaller number of large ones, because the thickness of the glass necessary in jars of large size obstructs induction through it. By an arrangement of many jars, an amount of electric force may be accumulated that would almost equal the destructive power of lightning. The battery used by Faraday in his experiments consisted of fifteen equal jars, coated eight inches upward from the bottom, and twenty-three inches in circumference; so that each contained one hundred and eighty-four square inches of glass coated on both sides, independently of the bottoms of the jars, which were of thicker glass, and contained each about fifty square inches. The total coated surface of the battery consequently comprised three thousand five hundred square inches of coated surface. The electrical battery at the Polytechnic Institution exposes a coated surface of nearly eighty square feet. To receive the full charge of such a battery would be instant death. A battery of nine

quart jars is sufficient to exhibit the deflagrating effects of electricity on a small scale; nor would it be safe to receive a shock from a battery of that size.

It is a fact deserving consideration that the accumulation of quantity diminishes the intensity of electricity. For instance, an electrical machine when in good action will emit sparks four inches long. When a Leyden jar is charged with twelve such sparks, the accumulated electricity will not force its passage through more than a quarter of an inch; and if the same quantity be distributed among the jars of an electrical battery, the discharge will not take place through the eighth of an inch. The quantity of electricity is in each case the same, but the state of intensity diminishes in proportion to the surface over which it is diffused. The difference between quantity and intensity is still more remarkably manifested in the different conditions of frictional and voltaic electricity, as will be subsequently noticed.

One of the peculiar phenomena of the electrical battery is the *residual charge*. When communication is made between the inside and outside coatings of a battery consisting of several jars, the whole of the electricity is not immediately discharged. On again making connection between the inside and outside coatings, after a short interval, a second discharge will occur, which, though comparatively feeble, might occasion a disagreeable shock. The cause of this residual charge is partly attributable to the accumulation of electricity on those parts of the jar just above the metallic coating; which portions, not being in direct contact with the metal, are not conducted with equal rapidity. Part of the charge also enters into the pores of the glass, and is thus removed from immediate contact with the metal.

The simplest kind of instrument employed for discharging a Leyden jar or an electrical battery is a thick curved piece of brass wire, fitted with a small ball at each end. One of these balls is applied to the outside coating, and when the other is brought near to the knob of the jar the electricity instantly passes through the wire with a smart snap or report, connection being thus made between the two charged surfaces of the jar. When, however, a discharger of this kind is employed for an electrical battery a slight shock is felt, owing to what is termed the *lateral discharge*; therefore, to avoid the inconvenience and the danger that might arise from holding the wire in the hand, an insulated wire is generally employed. Its form is represented in fig. 18, as applied in discharging a Leyden jar. Two thick brass wires, *a a*, of equal lengths, and terminated

with brass balls, are jointed together at *c* for the convenience of adjustment, and are cemented to a glass handle, *b*, which serves to insulate the wires from the hand, and prevents the

Fig. 18.

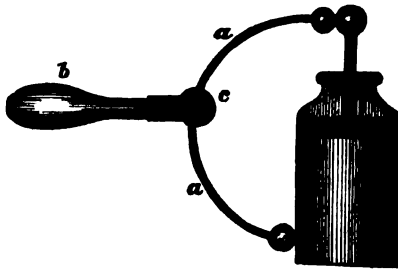

liability of any perceptible portion of the charge being received by the operator.

There has been much discussion among electricians on the subject of lateral discharges, in reference more particularly to the safety of lightning-conductors; we shall therefore notice in this place the cause of the phenomenon.

It is the case with electricity, even to a greater extent than with all fluid bodies, that it will discharge itself into every channel that is open to it. Thus, as in a mountain torrent some portion of the water will deviate from the straight and broad course into circuitous and narrow crevices, so will the highly tensive electric fluid force its passage through every conducting medium. Thus when a Leyden jar is discharged with an insulated wire, a small part of the charge passes through the circuitous and comparatively obstructive course offered by the body of the operator, by the floor, and by the table whereon the jar is placed. In the case of a single jar, the quantity of electricity that passes in that direction is imperceptibly small; but when several jars are combined, the lateral discharge may become unpleasantly strong, especially if the wire of the discharging-rod be not very thick. Even when an insulated discharging-rod is employed, it may be inferred that some portion of electricity will force its way along the glass; but it is so infinitesimally small as to be inappreciable.

Applying the experience and inferences deducible from experiments with the electrical battery to the more powerful effects of lightning, we are led to consider that every flash of lightning must be accompanied by lateral discharge, and that the quantity thus diverted from the direct and easiest path between the clouds and the earth will depend on the amount of resistance which that direct course offers. Therefore, though lateral discharge must, to some extent always occur, it may be rendered entirely innocuous by a sufficiently thick and unbroken lightning conductor.

VOLTAIC ELECTRICITY.

CHAPTER VI.

Electrical Phenomena Discovered by Galvani—Origin of the Voltaic Pile—Science of the Voltaic Battery—Ohm's Mathematical Formulæ—Chemical and Electrical Action of the Battery—The Daniell, the Smee, the Bunson, the Grove and the Chester Voltaic Batteries—Comparative Intensity and Quantity of the Grove, Daniell. and Smee Batteries.

ELECTRICAL PHENOMENA DISCOVERED BY GALVANI.

THAT remarkable form of electricity, known by the name of *Galvanism* or *Voltaism*, owes its origin to an accidental circumstance connected with some experiments on animal irritability, which were being carried on by Galvani, a professor of anatomy at Bologna, in the year 1790. It happened that the wife of the professor, being consumptive, was advised to take as a nutritive article of food, some soup, made of the flesh of *frogs*: several of these animals, recently killed and skinned, were lying on a table in the laboratory, close to an electrical machine, with which a pupil of the professor was making experiments. While the machine was in action, he chanced to touch the bare nerve of the leg of one of the frogs with the blade of a knife that he held in his hand, when, suddenly, the whole limb was thrown into violent convulsions. Galvani was not himself present when this occurred; but received the account from his wife, and being struck with the singularity of the phenomenon, he lost no time in repeating the experiment, and investigating the cause: he found that it was only when a spark was drawn from the prime conductor, and when the knife or any other good conductor was in contact with the nerve, that the contractions took place; and pursuing the investigation with unwearied industry, he at length discovered that the effect was independent of the electrical machine, and might be equally

well produced by making a metallic communication between the *outside muscle* and *crural nerve*. He did not for one moment suppose that the manifestation of electricity was the result of the chemical action upon the metals.

Galvani had previously entertained notions respecting the agency of electricity, in producing muscular action: these new experiments, therefore, as they seemed to favor his views, had with him more than ordinary interest. He immediately ascribed the convulsive movement in the limb to electrical agency, and explained them by comparing the muscle of an animal to a Leyden vial, charged by the accumulation of electricity on its surface, while he imagined that the nerve belonging to it performed the function of a wire, communicating with the interior of the vial, which would, of course, be charged *negatively*. In this state of things, if a communication by a good conductor were made between the muscle and nerve, a restoration of the electric equilibrium, and a contraction of the fibres, would ensue.

It is curious to notice how frequently the progress of discovery in the sciences is influenced by fortuitous circumstances, and in no case is it more striking than in the present. Had Galvani been as good an electrician as he was anatomist, it is probable that the convulsions of the frog would have occasioned him no surprise; he would immediately have seen that the animal formed part of a system of bodies under *induction*, and he would have considered the movements of the limbs of the frog, as evidence of nothing more than a high electroscopic sensibility in its nerves.

To perform the experiment with the frog's legs successfully, the legs of the frog are to be left attached to the spine by the crural nerves alone, and then a copper and a zinc wire being either twisted or soldered together at one end, the nerves are to be touched with one wire, while the other is to be applied to the muscles of the leg. Figure 1 shows the arrangement. There are several ways of varying this experiment. If a piece of copper, as a penny, be laid on a sheet of zinc, and if a common garden snail be put to crawl on the latter, he will be observed to shrink in his horns and contract his body whenever he comes into contact with the penny: indeed, after one or two contacts he will be observed to avoid the copper in his journey over the zinc.

The experiments of Galvani excited much attention among the men of science of that period: they were repeated and varied in almost every country in Europe, and ascribed to various causes. Some imagined them the effect of a new and

unknown agent: others adopted the views of the discoverer, and recognized them as peculiar modifications of electricity. The hypothetical agent which passed under the name of the

Fig. 1.

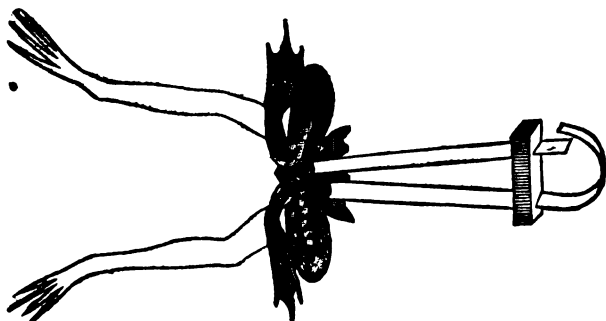

“nervous fluid,” now gave way to electricity, which, for a time, reigned as the *vital principle*, by which “the decrees of the understanding, and the dictates of the will, were conveyed from the organs of the brain to the obedient member of the body;” and this theory for a time so fascinated physiologists, that it was with difficulty that the explanations of *Volta*, viz. that the electric excitement is due to the mutual contact of two dissimilar metals—that by the contact the natural electricity was decomposed, the positive fluid passing to one metal, and the negative one to the other—and that the muscle of the frog merely played the part of a conductor—obtained assent.

ORIGIN OF THE VOLTAIC PILE.

It is to Professor Volta, of Pavia, that we are indebted for the first galvanic or voltaic instrument, viz. the *voltaic pile*; it was described by him in the Philosophical Transactions of 1800, and to him, therefore, the merit of laying the foundation of this highly interesting branch of science is due. The main difference between common and voltaic electricity (which are modifications of the same force) will be found to be this: the first produces its effects by a comparatively small quantity of electricity, insulated, in a high state of *tension*, having remarkable attractive and repulsive energies, and power to force its way through obstructing media: the latter is more intimately associated with other bodies, is in *enormous quantity*, but rarely attains a high state of tension, and exhibits its effects while flowing in a continuous stream along conducting bodies.

Galvani was an anatomist and not an electrician. He was firmly impressed with the idea that the convulsion of the frog's limb was owing to muscular action caused by animal electricity. He advocated this theory with the utmost zeal, and his whole efforts were directed toward maintaining this error. Electricians doubted the correctness of Galvani's philosophy, and on the other hand physiologists gave countenance to his notions, and throughout the continent they contended that the convulsions were produced by animal electricity.

The extraordinary zeal that was displayed by Galvani and his friends to maintain their physiological theory, caused electricians to investigate its correctness, and among them was Volta, of Pavia. In this state of the question Galvani died, at the close of the year 1798.

Two years after the death of Galvani, Volta produced his "pile" which demonstrated the correctness of his theory, as mainly advocated by him for several years previous. The electricians rejoiced over the practical illustration exhibited by the voltaic pile. It dispelled all faith in the erroneous reasonings of Galvani and his friends, that the motion of the frog was by animal electricity. Volta's triumphant success in demonstrating that the convulsions were produced by chemical action of the metals, was received with great joy by the electricians. It was a contest between anatomists and electricians, and the latter were the victors. The most strange part of the history was, that the achievement of Volta, was called *Galvanism* instead of *Voltaism*, as more modernly termed.

The original instrument of Volta is shown in fig. 2. It consists of a series of silver and zinc plates, arranged one above the other,

Fig. 2.

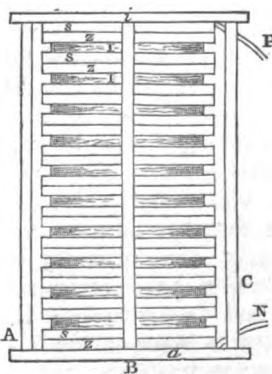

with moistened flannel or pasteboard between each pair. A series of thirty or forty alternations of plates, four inches square, will cause the gold leaf electroscope to diverge; the zinc end with the positive, and the silver with the negative electricity; a shock will also be felt on touching the extreme plates with the finger, when moistened with water. This latter effect is much increased when the flannel, or pasteboard, is moistened with salt and water;

in this case a small spark will be decomposed; from this we learn that the increase of chemical action, by the addition of

the salt, materially increases the *quantity* of electricity set in motion; but the pile will not in any sensible manner increase the divergence of the gold leaves,—its *intensity*, therefore, is not materially augmented.

The pile, represented by fig. 2, is connected at each end with a wire; *A B C* is the frame to hold the plates; *s s* are the silver plates, and *z z* are zinc plates; *ii* are the moistened flannels, and *i i* the top and bottom end boards; *P*, the positive pole, is connected with the wire at the top, and at the bottom *N*, the negative, to the wire. This was the voltaic pile as originally introduced by that distinguished philosopher Volta, of Pavia, in the year 1800.

In order to increase the *intensity* of the voltaic or electric current, it is necessary to increase the number of the plates; and to develop the greater *quantity* current, it is attained by the increase of the size of the plates. The centre of the battery or column is *neutral*, but the ends are in opposite electrical states; the zinc extremity negative, and the gold, silver, platinum or other metallic applications, positive.

THE SCIENCE OF THE VOLTAIC BATTERY.

The action of the voltaic pile gradually diminishes from the time it is first put together, until at length the effect appears to cease. This diminution of power is more rapid in proportion to the energy given to the pile in the first instance by the larger quantity of acid mixed with the water. To restore the original energy, it is necessary to decompose the pile, to clean the zinc and copper disks, and to moisten the cloths again. Such an apparatus is therefore attended with much trouble. To obviate it, Volta contrived another arrangement, which he called *à couronne de tasses*. He connected a piece of zinc to a piece of copper by soldering to them a short length of bent copper wire. Having procured a number of such connected plates, he put them into a row of glasses containing acidulated water, taking care so to dispose them that the zinc and the copper connected together should be in separate glasses, in the manner represented in figure 3.

To the copper plate in glass 1, a wire is attached to serve as a conductor for forming connection. In the same glass there is a zinc plate connected with the copper immersed in glass 2. In this manner each glass contains a zinc and copper plate connected by a wire, which are kept apart in the fluid, and the series may be continued to any extent. By bringing the wire attached to the first plate in connection with a similar wire

soldered to the zinc plate in the last glass of the series, the action immediately commences, and it is more or less intense according to the number of plates. This arrangement is, in

Fig. 3.

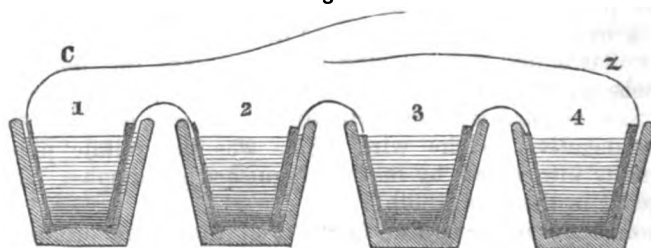

many respects, very superior to the pile. A much larger quantity of fluid can be brought to act on each plate, consequently the effect does not so rapidly diminish; the plates can be readily removed when the apparatus is not wanted, and the acidulated water may remain ready for the immersion of the plates when experiments are renewed.

The arrangement *à couronne de tasses*, as invented by Volta, continues, with some modifications for convenience in use, to form the voltaic battery that is most generally employed. A series of this kind, consisting of one hundred plates of copper and zinc four inches square, will generate electricity in sufficient quantity to exhibit in a powerful manner most of the phenomena of frictional electricity.

The metals that excite electricity by their mutual actions are ranged in the following order; those placed first acting in reference to those beneath as copper does to zinc.

Platinum.	Mercury.	Tin.
Gold.	Copper.	Iron.
Silver.	Lead.	Zinc.

Any two of the foregoing series will constitute what is termed a voltaic circuit. Thus zinc will excite voltaic action in combination with iron; iron will take the place of zinc when combined with tin; and tin will take the place of iron when combined with copper. The energies of these combinations increase as the metals are more distant from each other in the scale, the most powerful practical combination being zinc and platinum, the most incorrodible of all metals.

Though two plates are necessary in such an arrangement, only one of them is active in the excitement of electricity, the other plate serving merely as a conductor to collect the force generated. A metal plate is generally used for that purpose,

because metals conduct electricity much better than other substances exposing an equal surface to the fluids in which they are immersed; but other conductors may be used, and when a proportionately larger surface is exposed to compensate for inferior conducting power, they answer as well, and in some instances even better than metal plates.

The chemical action that gives rise to the excitement of electricity, takes place during the decomposition of the liquid in which the plates are immersed. It is essential, therefore, to the formation of an active voltaic arrangement, that the liquid employed should be capable of being decomposed. Water is most conveniently applicable for the purpose. Its elements, oxygen and hydrogen, are separated by the superior affinity of the oxygen for the zinc; especially when that affinity is heightened by the connection of the zinc with an incorrodible metal, to which the hydrogen gas of the decomposed molecules of water is attracted. Whether the electricity evolved be the cause or merely the effect of chemical action is at present unknown. In whichever way the phenomenon be regarded, the electricity appears to be excited at the surface of the active plate, thence to be transferred to the conducting plate, and back again through the connecting wire to the zinc, forming what is termed an electric current. The terms "electric fluid" and "electric current," which are frequently employed in describing electrical phenomena, are calculated to mislead the student into the supposition that electricity is known to be a fluid, and that it flows in a rapid stream along the wires. Such terms, it should be understood, are founded merely on an assumed analogy of the electric force to fluid bodies. The nature of that force is unknown, and whether its transmission be in the form of a current, or by vibrations, or by any other means, is undetermined. At the meeting of the British Association for the Advancement of Science at Swansea, a discussion arose on the nature of electricity, and Dr. Faraday was called on to give his opinion. He then said, "There was a time when I thought I knew something about the matter: but the longer I live, and the more carefully I study the subject, the more convinced I am of my total ignorance of the nature of electricity." After such an avowal from the most eminent electrician of the age, it is almost useless to say that any terms which seem to designate the form of electricity are merely to be considered as convenient conventional expressions.

Water being a very imperfect conductor, it offers so much resistance to the passage of the electric current that a very small quantity of voltaic electricity can be excited when water

alone is employed; especially when the plates are at a considerable distance apart. By the addition of an acid or a neutral salt to the water, the conducting power is greatly increased, and the excitement is augmented in a corresponding degree. It is a disputed point whether the increased action from the addition of acids arises from the improved conducting power alone, or whether it is to be attributed also to the increased affinity of the oxygen to the zinc. The effect is most probably owing to the joint effort of the two forces.

In the opinion of Faraday, the conduction of electricity through liquids is accompanied by, if it be not owing to, the successive decomposition of the intervening particles. When a copper and zinc plate, for example, are connected together and immersed in diluted acid, the oxygen in the particle of liquid contiguous to the plate enters into combination with the metal, and its equivalent quantity of hydrogen is disengaged. The hydrogen is not immediately liberated, but is transferred from particle to particle of the liquid in a continuous chain till it reaches the conducting plate, where, not meeting with any more liquid particles to which it can be transferred, it is liberated in the gaseous form. The intervening particles are supposed to undergo temporary decomposition during this transfer from plate to plate, and to assume a polar condition, the oxygen and hydrogen occupying opposing places in each particle of liquid.

The annexed diagram, fig. 4, shows, in an exaggerated form,

Fig. 4.

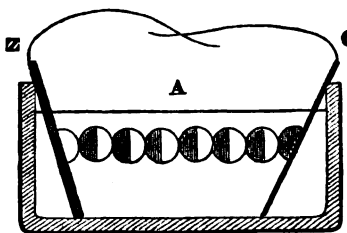

the chain of particles of water through which the decomposing influence is supposed to be transmitted. Voltaic action having been established through water in the vessel A from the zinc plate z to the copper plate at c, the particles between the two metals are thrown into a polar state;

the oxygen of each being directed toward z, and the hydrogen toward c. The zinc plate absorbs the oxygen of the particle nearest to it, and the liberated hydrogen combines with the oxygen of the next adjoining particle, and in this manner a continuous interchange takes place. According to this view of the conducting power of fluids, no fluid can conduct electricity unless it be capable of being decomposed; the conduction being necessarily accompanied by a train of successively decomposed particles.

OHM'S MATHEMATICAL FORMULÆ.

The causes that obstruct the development of electricity in a current, have been minutely investigated by Professor Ohm, of Nuremberg, who has reduced them to mathematical formulæ. The free development of electricity is opposed, in the first place, by the affinity of the elements of the exciting liquid for each other, tending to resist decomposition; secondly, by the imperfect conduction of the fluid itself; and in the third place, by the resistance of the conducting wires. As the formulæ deduced by Professor Ohm from these investigations have received general acceptance among electricians, it is desirable to insert them:

" E = electromotive force, equivalent to the affinity of the exciting liquid for the generating metal, and corresponding to the amount of electricity which would appear in current if all opposing causes were removed.

" R = resistance opposed to E by the contents of the cell, arising for the most part from the affinity of the elements of the exciting liquid for each other.

" r = external resistance, arising chiefly from the imperfectly conducting nature of the wires used to convey the current.

" a = active force, or the amount of electricity which really reaches the end of the conducting wire.

$$a = \frac{E}{R+r}$$

"The theoretical value of E is diminished materially in practice by the affinity of the conducting plate for the ingredient of the exciting fluid, which tends to combine with the generating plate; this affinity, however weak, is still seldom absolutely null. The mutual affinity of the separated elements of the fluid evolved at the surfaces of the plates also lessens the intensity of E .

"The internal resistance, R , varies directly with the distance, D , between the two plates, and is inversely as the area of the section, s , of the exciting liquid. Thus the real resistance is equal to the former divided by the latter, or

$$R = \frac{D}{s}$$

" r , or the external resistance, so far as it is dependent on

the conducting wire, varies *inversely* as the square of the diameter of the wire, S , and directly as its length l , or

$$r = \frac{l}{S}$$

From these formulæ are deduced the following general laws :

1st. The electro-motive force of a voltaic circuit varies with the number of the elements, and with the nature of the metals and liquids which constitute each element ; but it is in no degree dependent on the dimensions of any of their parts.

2d. The resistance of each element is directly proportional to the distances of the plates from each other in the liquid, and to the specific resistance of the liquid ; and it is also inversely proportional to the surface of the plates in contact with the liquids.

3d. The resistance of the connecting wire of the circuit is directly proportional to its section.

It must be remarked that the foregoing estimate of electrical force and resistance does not take into account the actual loss of electricity by the want of proper direction. The chemical action that converts any given quantity of zinc into a metallic salt, develops, with the best arrangement, a given quantity of electricity. Let it be assumed that one ounce of zinc will generate an amount of electricity equivalent to 1000 ; that quantity will not be diminished by the resistances considered by Professor Ohm. Those resistances relate exclusively to the time in which a given amount of electricity can be generated, and have no relation to actual loss of electric force. Thus, in a well-constructed voltaic apparatus no more electricity is generated than can flow in a current through the conducting wire. If the resistance to the current be increased by diminishing the thickness of the wire or by adding to its length, the action of the generating-plate is diminished in a corresponding degree, so that if only half the electricity is developed, only half the quantity of zinc is consumed ; and to whatever extent the resistances are increased the ounce of zinc will, theoretically at least, produce its equivalent of electricity, though in a longer time.

CHEMICAL AND ELECTRICAL ACTION OF THE BATTERY.

In practice, however, an actual loss of electricity does generally occur, arising principally from what is called "local action" in the generating-plate. If a plate of zinc were per-

fectly pure and homogeneous, no chemical action would ensue when it was immersed in diluted acid. But zinc, as it is commonly procured, contains copper, iron, and other impurities, which serve to set up voltaic action over its whole surface when exposed to diluted acids, which cause a rapid decomposition of the liquid. The positive and negative electricities thus generated immediately combine, and are neutralized imperceptibly, and thus so much electric force is absolutely lost. This local action is in a great measure, though not entirely, prevented by amalgamating the zinc plates with mercury: this is readily done by first dipping them in diluted sulphuric acid, and then sprinkling a few drops of mercury on the surface and rubbing them over with a cork. The effect of amalgamation is to produce a homogeneous surface, and to protect the zinc from the action of the diluted acid until the affinity of the liquid for the metal is increased by the agency of the conducting plate.

The electricity generated by a single pair of plates possesses a very low degree of intensity. The *quantity* is only limited by the size of the plates, but no increase of size alone will add to the *intensity* of the force. Thus, though a pair of large zinc and copper plates, excited by diluted sulphuric acid, will fuse any of the metals, they cannot decompose a drop of water; because in the latter case the force is not sufficiently energetic to overcome the resistance of the fluid.

In tracing the course of the electric current thus established, no notice has been taken of the action of the second zinc plate. If that be considered as inactive, except as a conductor, the quantity of electricity transmitted would be very small, owing to the resistance of the imperfectly conducting liquid. But the zinc plate in the second cell is acted on by the diluted acid equally with that in the first; and the effect is to nearly double the energy of the electric current excited by the action of the acid on the first zinc plate.

According to this view of the action of a voltaic battery consisting of two pairs of plates, the electricity excited by the first zinc is transferred to the second, where its force is doubled by the excitement of an equal quantity, and both united traverse the wire of the return circuit. On arriving at the first zinc, half the quantity is parted with; but an equal quantity of fresh electricity is excited, and is carried on to the second zinc, where the same process is repeated; and thus the electrical equilibrium is continually disturbed and restored after traversing the wires that connect the plates at the ends. When greater numbers of zinc and copper plates are united in a series, a

similar transference of electricity from place to place takes place with a progressively increasing *quantity* and *intensity* of force, the action being continued as long as the series remains unbroken, or until the fluid becomes saturated with sulphate of zinc, and further chemical action is prevented.

It is necessary to state that the preceding explanation of the action of the voltaic battery differs from the view taken of it by Dr. Faraday, and after him by most other writers on the subject. In the opinion of Dr. Faraday, addition to the number of plates in a series occasions no addition to the *quantity* of electricity generated by the first pair of plates, but merely serves to give increased *intensity* to that quantity. Thus the most powerful effects produced by a voltaic battery consisting of 1000 pairs of plates are assumed to be caused by the same *quantity* of electricity that is excited by a single pair only of the series; the exalted action in the former case being attributed to an increase of intensity without any addition to quantity.

This view of the nature of the action of the voltaic battery is supported by numerous ingeniously-contrived and apposite experiments; but though fully disposed to pay the highest possible respect to so great an authority as Dr. Faraday, an opinion is entertained that he has failed to establish the position that increased intensity is not accompanied by addition to quantity.

THE CRUIKSHANK VOLTAIC BATTERY.

There are many arrangements of voltaic batteries for the development of accumulated electric force in different modes, but they all depend on the same principle. The most compact is Cruikshank's modification of the voltaic pile, fig. 5.

Fig. 5.

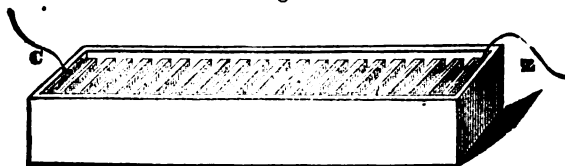

Zinc and copper plates of equal size are soldered together, and then cemented into a wooden trough. Each pair of plates is fixed less than half an inch from each other, care being taken that all the zinc and copper surfaces are turned the same way. The compartments between the plates form water-tight cells, into which diluted acid, or other exciting liquid, is poured. A piece of wire is introduced at each end to complete the circuit through any substances to be subjected to the voltaic action.

A series of fifty small double plates may be cemented into a trough two and a half feet long; and two such batteries, with plates two inches square, will give a rapid succession of smart shocks, and will exhibit most of the phenomena of voltaic electricity. The disadvantages of a battery of this kind are, that the exciting liquid cannot be emptied at the end of each experiment without much trouble, and there is some difficulty in cleaning the plates when they become corroded. By emptying the cells as soon as possible and washing them with water, a battery of this construction may, however, be kept in order for a considerable time; and when voltaic electricity of high intensity and small quantity is required, a Cruikshank battery with plates about two inches square, is very convenient.

Figs. 6 and 7 represent the full battery. Fig. 7 is the trough divided into cells insulated each from the other.

Fig. 6 is a wooden board having attached to it copper and zinc plates, the white are copper and the dark, zinc. These plates fit into the cells, and may or may not rest upon the bottom.

The original form of the trough has been recently very extensively used for the electric telegraph, though made of other materials than earthenware. Most of the batteries of the Electric Telegraph Company, until very recently, were constructed in wooden troughs, with partitions of slate made water-tight by means of marine glue. These, again, are being supplanted by troughs made of gutta-percha, which are very much lighter, and the cells can be more effectually prevented from leaking. The plates of these batteries are connected by strips of copper, which are bent into arches, so as to admit of each unattached pair of plates being inserted into separate cells. The zinc plates are well amalgamated, and are allowed to remain in the cells day and night, the local action being in a great measure prevented by filling each cell with fine sand, and by using sulphuric acid diluted with about twelve parts of water: A voltaic battery, with sand and diluted sulphuric acid, will continue in good action, with occasional additions of acid, for two months before the zinc plates require to be cleaned or re-amalgamated.

Fig. 6.

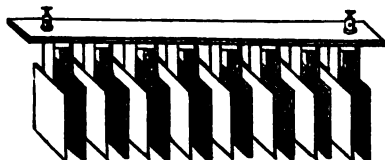
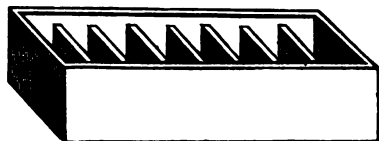

Fig. 7.



Batteries in which graphite is substituted for plates of copper, have been introduced by Mr. C. V. Walker in working the electric telegraphs of the Southeastern Railway Company, and with very good results. One of these batteries of twelve pairs, of which a record was taken, was kept in daily action for ninety-seven weeks without having been washed or having the sand changed. It was supplied with about a dessert-spoonful of acid-water twenty-one times during the period it was in action, and six times with merely warm water. In one instance it did duty for seventy-seven days without having been touched.

Dr. Wollaston contrived the arrangement shown in fig. 8

Fig. 8.

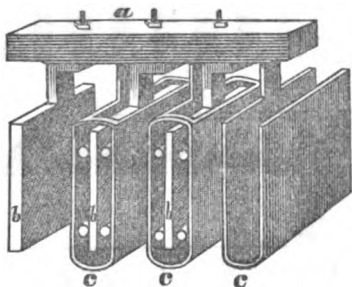

for obtaining the greatest amount of power from a given surface of zinc. The copper plates *c c c* are doubled, so as to expose a conducting surface to both sides of the zinc plates, *z z z*. The plates are also brought as close together as possible without actual contact. They are secured to a bar of wood, and are kept apart by pieces of cork. With a battery of this

kind, consisting of a few pairs of large plates, prodigious heating power is produced, though the intensity of the electricity is too feeble to communicate a shock.

THE DANIELL VOLTAIC BATTERY.

The battery invented by Professor Daniell, is constructed on a different principle. It is found in the voltaic arrangements, that the zinc and copper plates immersed in the same cell are liable to have their action impeded, and ultimately altogether arrested, by the transfer of zinc to the copper surface. The action of the conducting plate is also greatly retarded by the accumulation of hydrogen gas; so much so, indeed, that very frequently, after the first minute the battery has been put in action, not more than one tenth of the original power is obtained. In Professor Daniell's battery the zinc and copper plates are kept apart by means of porous earthenware cells, or by pieces of animal membrane, which, though sufficient to prevent the passage of metallic particles, do not materially interrupt the voltaic action.

Fig. 9 shows an arrangement of a single cell of this kind: *c* is a copper cylindrical vessel, with a binding screw *B*, soldered to one edge for the purpose of holding a connecting wire. Into this copper cylinder a porous tube *D*, closed at the bottom, is introduced; and into the tube is placed a rod of amalgamated zinc *z*, with a bending screw at the top. A solution of muriate of soda (common salt) is poured into the porous tube, and the outer copper vessel is nearly filled with a saturated solution of sulphate of copper to which a little sulphuric acid has been added.

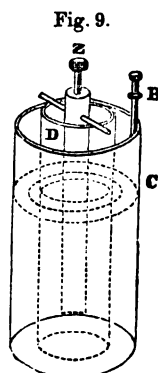

When metallic connection is made between the rod of zinc and the copper cylinder, active excitement of voltaic electricity occurs. The oxygen of the acid combines with the zinc, and the liberated hydrogen passes through the porous cell to the copper. It does not, however, escape in the form of gas, but it enters into combination with the oxygen of the sulphate of copper, and the metal being thus deprived of its oxygen, becomes "revived," and is deposited in a metallic form on the inner surface of the cylinder. By the continued absorption of hydrogen by the sulphate, and the deposition of copper, a bright conducting surface is maintained; and this constant renewal of the conducting surface not only increases the intensity of the action, but maintains it with a steadiness that cannot be attained by any of the batteries previously described.

Fig. 10 represents a vertical section of the Daniell battery, used on some of the American telegraph lines, in the local circuits. It consists of a double cylinder of copper *c c*, with a bottom of the same metal, which answers the purpose both of a voltaic plate and of a vessel to contain the solution. The space between the two copper cylinders receives the solution. There is a moveable cylinder of zinc, marked *z*, in the sectional view, which is let down into the solution whenever the battery is to be put in action. It hangs suspended in the solution, and presents its two opposite surfaces to the action of the liquid, and to the inner and outer cylinders respectively. The binding screw *n* is connected with the zinc, and the screw *p* with the copper cylinder.

Fig. 10.

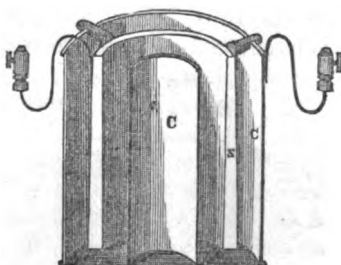

The binding screw *n* is connected with the zinc, and the screw *p* with the copper cylinder.

Fig. 11.

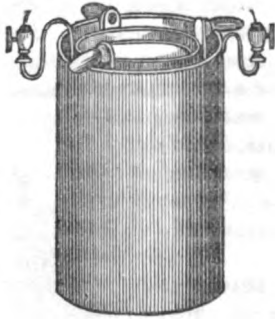

Fig. 11 is a perspective view of the same battery. The liquid employed to put this battery in action, is a solution of sulphate of copper, or common blue vitriol, in water. To prepare it, a saturated solution of the salt is first made, and to this solution is then added as much more water. A pint of water is capable of dissolving one fourth of a pound of blue vitriol, so that the half-saturated solution employed, will contain about two ounces of the salt to the pint. A small portion is sometimes added to increase the permanence of its action.

Fig. 12.

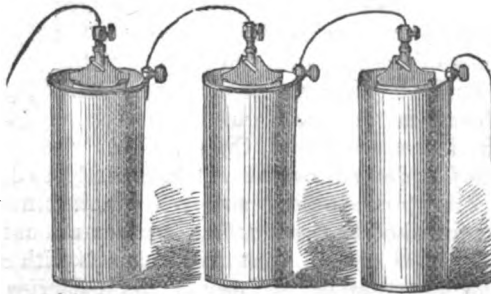

Fig. 12 represents the union of the cells of this battery, as in common use on some of the telegraph lines. Fig. 13 is a section of it, being the zinc and the porous cylinder. Fig. 14 is a covered cell and is called a protective battery.

Fig. 13.

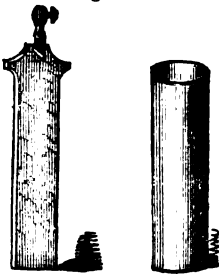

Fig. 14.



The Daniell battery, having thus been described in its especial arrangement, I will add a few explanations relative to

its peculiar advantages. It is called a "constant" or "sustaining" battery, from the regularity and duration of its action. Mr. Smee denies the correctness of this name. He says, "It is often thought to signify long-continued action, whereas these properties are really different; for a battery may be constant, but only remain in action for a short period; and, again, a battery might remain in action for years, and not be constant in its action." Among practical electricians, however, the Daniell battery is recognized as a "constant battery," and as such it has been used in the local circuits of many telegraph lines, with much economy and satisfaction.

THE SMEE VOLTAIC BATTERY.

The voltaic arrangement contrived by Mr. Smee deserves special notice from its general utility. The principal differences

Fig. 15.

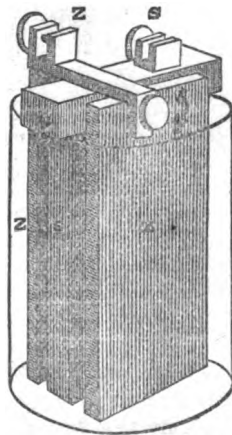

between it and a battery of Dr. Babington's arrangement consist in the material of the conducting plate and in the mode of placing it. The conducting plate is made of silver-foil platinized; that is, a thin coat of platinum is deposited on the silver by the electrotype process. The minutely-divided particles of platinum that thus cover and adhere to the silver, present a greatly-enlarged surface to liquid in which it is immersed, by which means a smaller-sized plate answers equally with a much larger one of smooth metal. Platinum also being a metal less readily oxydized than copper, the effect of the voltaic arrangement is heightened by the greater dissimilarity of the two metals. The platinized silver-foil is fixed in the centre of a wooden frame *s*, and two zinc plates, *z z*, well amalgamated, are attached to the upper rim of the frame by a brass clamp, which has a binding screw connected with it. By this arrangement the zinc plates can be very readily removed and cleaned. In this respect a Smee's battery is more convenient than any other; its action also approaches a Daniell's battery in constancy. These are important advantages, which render this form of voltaic battery the best that can be used for general purposes.

The substitution of graphite for the platinized silver plates

promises to be a still further improvement. With graphite conducting plates there is no occasion for the wooden frame. A single zinc plate, with a binding-screw soldered to it, occupies the central place, instead of the platinized foil, and two flat pieces of graphite may be clamped on each side; care being taken to insulate the zinc from the graphite by small strips of varnished wood. It will be observed that in this disposition of the apparatus with the graphite, the position of the exciting zinc in reference to the conducting surfaces is transposed, as well as the proportions of each to the other being reversed; a single plate of zinc being placed between two conducting surfaces instead of the conducting surface being in the centre, with a zinc plate on each side.

Fig. 16 is another form of the Smee cell as practically applied by Mr. Hall of Boston, with great success as to its effi-

Fig. 16.

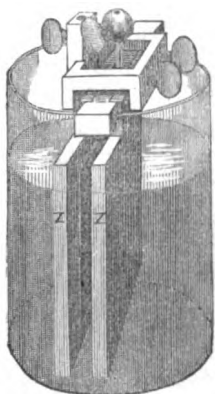
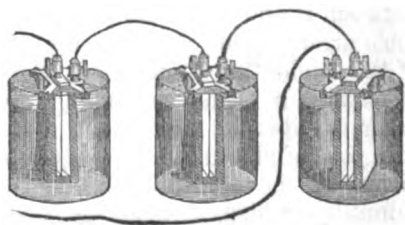

Fig. 17.



ciency and long service. The zinc plates are large, and the platinized sheet very thin. Fig. 17 is composed of three cells united by the wires, one connecting with the copper and the other with the zinc, the two poles of the battery.

The object in every case is to obtain from a given quantity of the exciting metal the greatest possible amount of current electricity, without allowing the power to be wasted in other ways. The consumption of a given weight of zinc cannot, by any possible combination, excite more electricity than will decompose a quantity of water equivalent to that which is decomposed by the chemical affinity of the metal for oxygen. Thus, supposing two grains of water to be decomposed in the generating cell, and eight grains of zinc to be oxydized, the electricity generated during the process cannot be more than

sufficient to decompose another two grains of water. The power obtained, even by the best arrangements hitherto contrived, seldom amounts to so much. By increasing the chemical action of the liquid on the generating plates, the energy of the battery is increased, but most frequently not in proportion to the consumption of zinc. By bringing the plates in the generating cells nearer together, the energy of the battery is also increased, by diminishing the intervening fluid resistance; but this may be attended with waste of power if the plates be brought too close.

THE BUNSEN VOLTAIC BATTERY.

Professor Bunsen has substituted carbon for platinum, in nitric acid batteries, with good effect. To overcome the difficulty of shaping graphite into the required form, he made a composition of coke and coal in fine powder, which were heated together in iron moulds, and thus formed a solid mass of carbon of the required form. To give further solidity to the mass, it is plunged into a syrup of sugar, afterward dried, and then subjected to intense heat in covered vessels. The form which Professor Bunsen prefers for his carbon conducting surfaces is cylindrical, and the shape of his battery resembles that of Daniell's. To make a good connection between the carbon and the connecting wire, a ring of copper is fixed round the top of the carbon cylinder to which the wire is soldered. The accompanying diagram shows the several parts of one of the cells of a Bunsen's battery, *A* being the carbon cylinder, with its copper ring and attached wire, *B* the porous cell into which it is introduced, *C* the cylinder of amalgamated zinc that surrounds the porous cell, *D* is the external earthenware jar, and *E* represents the arrangements of the whole completed.

Fig. 18.

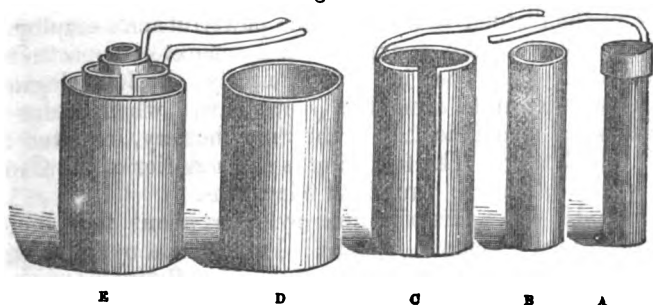

Bunsen's battery is extensively used on the Continent, and

it is represented to be, when in good action, nearly equal to Grove's in power, and superior to it in constancy.

I noticed this battery on the German lines. Telegraphers expressed themselves highly in favor of it. Its intensity was highly commensurate with the wants of the telegraph.

Nitric acid, mixed with its own bulk of water, is poured into the vessel in contact with the carbon. A mixture of sulphuric acid 1 part, water 25 parts, by measure, is poured into the porous cup in contact with the zinc. This arrangement may be varied by using a solid cylinder of carbon in the porous earthen vessel in the centre, and a zinc cylinder outside next to the glass. This latter method, I noticed in the central office in Paris, from which place a battery of 40 such couples worked all the lines from Paris. The batteries are renewed every week. A current of great intensity is generated by this combination.

In Denmark, Prussia, Austria and other German states, I noticed the carbon batteries in very extensive use, but no nitric acid was employed; weak sulphuric acid, 1 of acid to 20 of water, by measure, is placed in contact with the zinc, which is well amalgamated, and acid of 1 part sulphuric, to 9 parts water, is used in contact with the carbon plate. All telegraphers with whom I discussed the relative merits of the carbon, with that of the platina, were of the opinion that for telegraphic service the former was the best, and that without the use of the nitric acid, a current of sufficient intensity could be generated.

THE GROVE VOLTAIC BATTERY.

The most powerful voltaic battery that has yet been brought before the public, is that of Professor Grove, invented about 1839. The *intensity* of its action depends on associating two metals the most dissimilar in their chemical characters, and exposing one of them separately to the strongest exciting acid. This can only be done by using a porous cell, which keeps the zinc from the distinctive action of the powerful acids employed, and to which platinum is exposed in a separate compartment.

This battery has been in use on nearly all the telegraph lines in America until some five years since, when many of them adopted a modification of the Smee battery, invented by Mr. C. T. Chester. The following is a description of the Grove battery as used on the American telegraphs.

Figure 19 represents the zinc cylinder about four inches high, and three pounds in weight. Fig. 20 is a cylinder with the platina strip soldered to the arm B at c. Between A A is D, an opening, to give free action to the chemicals.

The porous cup, fig. 21, is made of the same materials as stone-ware, and baked without being *glazed*. A represents

the rim surrounding the top. From the under side of the rim to the bottom, it is three inches long, and one and one quarter

Fig. 19.

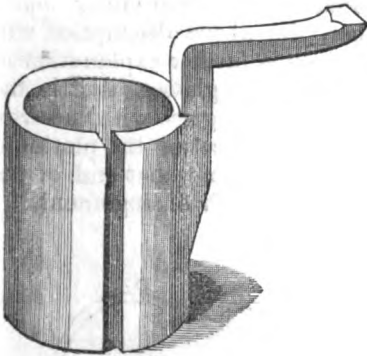

Fig. 21.

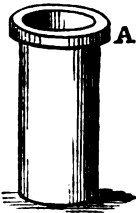

Fig. 20.

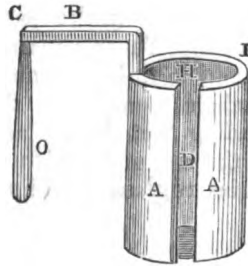
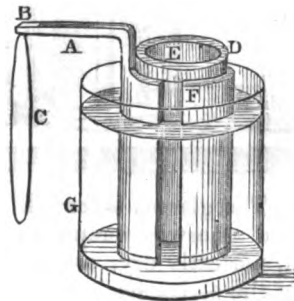

Fig. 22.



in diameter. The rim projects one quarter of an inch, and the shell of the cup is one eighth of an inch thick.

These several parts are placed together thus: The porous cup is set in the hollow of the zinc cylinder, represented by H, with the rim of the cup resting upon the top of the zinc at I. The zinc cylinder is then placed in the glass tumbler. The whole is represented in fig. 22.

D represents the porous cup, F the zinc cylinder, G the glass tumbler, A the projecting arm of the zinc, C the platinum plate, and B the overlapping of the platinum plate upon the zinc arm, where it is soldered to it.

It is now in a condition to receive the acids, which are two: first, pure nitric acid, and second, sulphuric acid, diluted in the proportion of one part of sulphuric acid to twelve of water. First fill the porous cup with the nitric acid, to within one quarter of an inch of the top; then fill the glass with the dilu-

ted sulphuric acid, till it reaches to a level with the nitric acid in the porous cup. One cell of the battery is now ready for use; and as all the other members of the battery are similarly constructed, and are to be prepared and filled with their appropriate acids in the same manner, the above description will suffice. There remains, however, some further explanation in regard to the extremities of the series of glasses, that is, the mode of connecting the zinc of the first glass with the wire leading from it, and also the mode of connecting the platinum of the last glass with the wire leading from that end of the series of glasses. Figure 23 represents their arrangement.

Fig. 23.

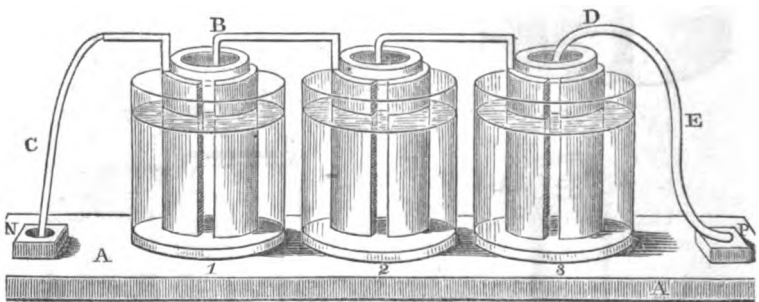

The glasses being all separately supplied with their acids, and otherwise prepared, they are put together upon a table, A, perfectly dry, and made of hard wood. The first member of the series has soldered to its zinc arm a strip of copper, c, which, extending downward, has its end, previously brightened and amalgamated, immersed in a cup of mercury at n, the cup being permanently secured to the table. Then the second glass is taken, and the platinum, b, at the end of the zinc arm, is gently let fall into the porous cup, so that it shall be in the centre of the cup, and reaching down as far as its length, when the glass rests upon the table. The third glass is then taken and placed in the same manner, and so on to the last. The last glass has, in its porous cup, the platinum plate, d, soldered to a stripper, e, which is so constructed as to turn at the top, and admit of the easy introduction of the platinum into the porous cup, while the other end is fastened to the metallic connection with the line wire. The line wire is, also, connected with the mercury cup n. Sometimes the line wires are fastened with binding screws to the batteries as represented by fig. 24. When a large battery is required, the cells are placed in regular order as represented by fig. 25 excepting it is not uni-

versal to place the batteries in boxes. There are many contrivances having in view the insulation of the battery, to prevent local action, and cross currents from one cell to the other, generating various circuits of quantity electricity. I have seen the batteries, set upon tables covered with a sheet of gutta-percha, at other times I have seen the cells placed on the flat surface of glass, or on the edges of strips, cut an inch wide, and fastened in saw grooves. The glass strips were placed an inch apart. This

Fig. 24.



Fig. 25.

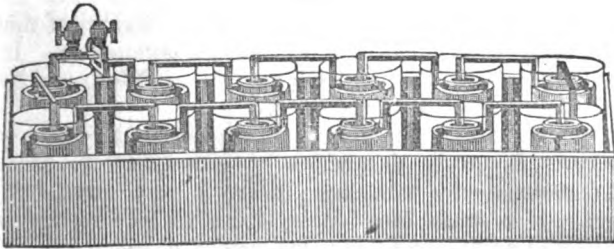

was quite an effective insulation. The best arrangement for insulating the cells, one from the other, has been gotten up by Mr. J. H. Wade, of the Western Union lines. The Wade insulator is squared flat at the top, and it is set on wooden pins, coated with gum lac, and fixed in the table. With this application there can be no cross currents, and the full voltaic force of intensity can be thrown over the lines for the uses of telegraphing.

Fig. 26.

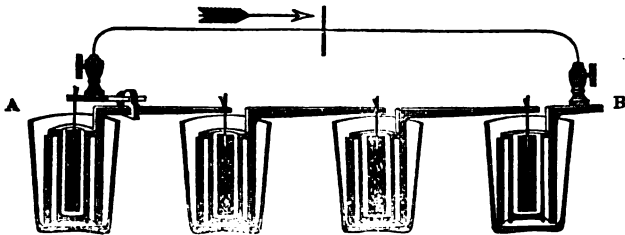

Fig. 26 represents a sectional view of the Grove battery, as practically employed on many lines, A is the platinum or positive pole of the battery, and B the zinc or negative pole. The chemicals act upon the zinc, and the platinum leads the electrical force generated in the cell, to the next in course and thence on. The current is indicated by the arrow, running from the platina end to the zinc or negative pole of the battery ;

the circuit is thus completed. While the action proceeds, the zinc end is charged with *negative*, the copper with *positive* electricity. The current moves from the zinc to the copper or platina in the fluid, and from the latter by the intermediate wire to the zinc. Thus the wire attached to the copper or platina is positive, and that to the zinc is negative. If the circuit be several hundred miles the philosophy will be the same. On the telegraph lines, one end of the battery is connected with the earth, and the other with the line wire, thence to the terminal station, where that end of the wire is, also, connected with the earth. The opinion is entertained by some, and disputed by others, that the current flows over the line and returns through the earth. I have entertained the belief that the current does return to the source of its generation. It is a question, however, that no one is able to determine by the present known state of the science.

The Grove battery has proved its superiority for the greatest *intensity*. In getting this intensity—the power to overcome long distances—the telegraph incurs a very great expense. The zincs of a main line battery have to be renewed about every three months, and the consumption of nitric acid is very great.

Before using a zinc it should be well amalgamated with mercury, which penetrates the zinc if they are first immersed in water diluted with muriatic acid. It was my practice to use but $\frac{1}{30}$ part sulphuric acid in the water for the battery service, and every night the porous cups were emptied into a vessel and kept closed until morning. The zincs were removed from the tumblers and placed inverted in a trough of water acidulated with sulphuric acid. In the morning, the zincs were rubbed with a brush and the mercury caused to be diffused over the zinc. To every ten cups of nitric acid used in the battery, one additional cup of pure acid was mixed. By this process of mixing fresh acid every morning, the battery produced a steady and an even current on the line. The water, diluted with sulphuric acid, should be removed from the tumblers twice each week. Great care should be observed not to injure the connection between the zinc and the platina. On soldering platina to the zinc, the greater the surface of the platina applied to the zinc, the greater will be the power of the battery. The conductivity of the metals and fluids employed, should be commensurate, one with the other, in order to have the chemical and electrical action of the different elements uniform.

It is advisable for the telegrapher to make every connection of the different metals full, with the greatest amount of surface

contact possible. The strength and efficiency of a battery of *intensity*, or of *quantity*, can always be determined by the fixed laws concerning the conductivity of the respective elements employed in the voltaic organization.

In the construction of the battery, care should be taken to insulate each cup or cell from the other. I have frequently seen a battery set upon a wet table, and the tumblers wet with moisture. When thus arranged, the chemical action of the battery will be more than ordinary, and several local circuits will be in electrical action. To prevent such hindrances to the efficiency of the battery, and to concentrate the greatest amount of electrical intensity, for purposes of the line, Mr. William M. Swain, the President of the Magnetic Telegraph Company, had constructed tumblers with feet, as represented by figs 27 and 28.

Fig. 27.



Fig. 28.

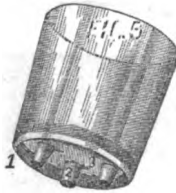

Fig. 29.

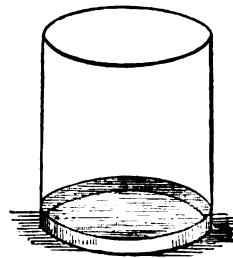

Fig. 27 is a sectional view of a tumbler. Beneath it is concave as seen by fig. 3, with the rim 1. The feet 2, project from the hollow below the rim 1. If moisture collects upon the glass it falls from the rim 1, or it remains upon the glass in globules. The arrangement is simple but of great importance to the efficiency of the voltaic organization, and no battery should be constructed without tumblers thus manufactured. The ordinary tumbler, fig. 29, sets upon the battery table, and the moisture gathered upon the glass soon forms a watery connection from one glass to the other, producing local action on many local circuits. The plan adopted by Mr. Swain economises the use of the battery, and attains a battery of intensity, so indispensable in the working of the line, and prevents the action of innumerable local circuits in the generation of quantity electricity.

The local battery, generally composed of two or three cells, is more active, generating a *quantity* current for the working of the register. The circuit is confined to the station, the wire is larger in the register coils than in the relay, and the battery is more consuming than the main line series. The acids are

renewed, sometimes every day, but generally whenever the register magnet requires an increased efficiency for the magnetization of the soft iron in the register spools.

THE CHESTER VOLTAIC BATTERY.

The next organization requiring especial notice is that generally known as the Chester battery, and extensively used on the American lines, both on the local and main circuits. The advantages in its use are, economy in the use of material, labor in taking care of it, and its uniform efficiency in generating a voltaic current suitable for practical telegraphing.

Fig. 30 is a representation of the Chester main battery, *A A* are insulated wooden bars, *B B* are brass clamps with the bind-

Fig. 30.

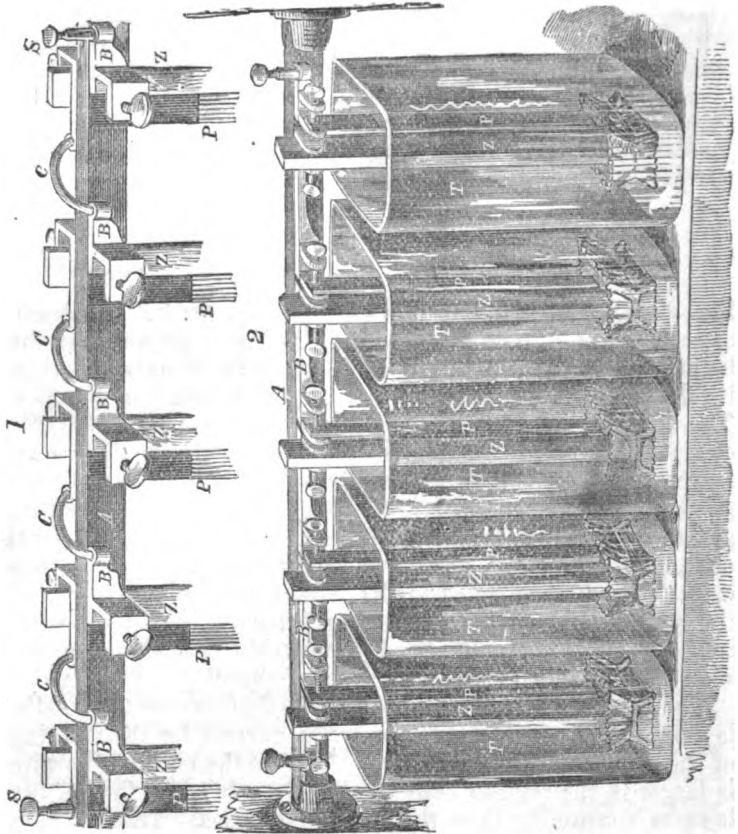

ing screw attached, *z z* are the zinc plates fastened by the clamp on the one side of the wooden bar; *p p* are platinized plates fastened by the clamps on the opposite side of the wooden bar from the zinc plates, *t t* are the elongated tumblers. In battery 1 the wooden bars rest upon the glasses, and in battery 2 they rest upon iron brackets fastened to supports. The wooden bar is covered with lac to prevent it from being destroyed by the acid. Gutta-percha and hard rubber bars have been used on some of the batteries, and they have served well. In the bottom of the tumblers are set small glass cups, in which are placed about two tablespoonfuls of mercury.

This battery has been widely extended over the American continent, to South America, Australia, and the Islands. Its cheapness, freedom from poisonous fumes, and long use without renewal, has gained for it many friends.

The battery is very cleanly, and can be placed on shelves or ornamented casings on the side of the wall in the operating room. Each zinc plate being supplied with a cup of mercury, the amalgamation continues, undisturbed by destroying acids. The zincs thus arranged continue in service about one year. The platinized plate with care in handling will not decay. The battery requires to be renewed or rebuilt about four times a year.

The following relative computations have been made in regard to the Grove, the Daniell, and the Chester batteries:

The Grove battery consumes $1\frac{1}{2}$ pounds of nitric acid, $1\frac{1}{2}$ pounds of zinc, 1 pound of sulphuric acid.

The Daniell battery consumes 4 pounds of sulphate of copper, $1\frac{1}{2}$ pounds of zinc, 1 pound of sulphuric acid.

The Chester battery consumes $1\frac{1}{2}$ pounds of zinc, 3 pounds of sulphuric acid.

The only acid used in the Chester battery is sulphuric, in pure water and in very small quantities.

In a telegraph main-battery, the great object to be attained is the greatest degree of *intensity*, or *energy* of action or motion, to overcome distance; this intensity is obtained by increasing the number of the cells.

In a telegraph local battery, a *quantity* current is necessary. The circuit is short, and intensity current is not necessary. A quantity current depends upon the surface of the plates; and, to increase the *quantity* force, it is necessary to increase the size of the plates employed. These are the indispensable considerations to be regarded in the organization of any battery for telegraphic service.

Fig. 31 represents the Chester local battery, as practically employed on many of the American lines. *z* is the zinc cylin-

ders; *p* c the porous cup; *c* is the perforated copper chamber, attached, and *g* is the glass tumbler. It is arranged upon the

Fig. 31.

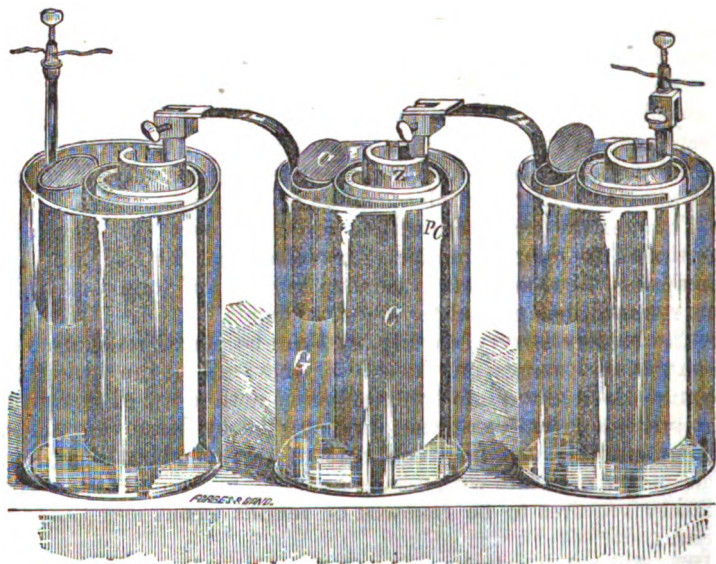

principles of the Daniell battery. A *quantity* current is generated by this combination fully equal to the requirements of the local circuit. The peculiar form of the metallic parts, present to the acidulated chemicals surface sufficient to produce the desired results. This form of battery has been very extensively used, and with advantages worthy of appreciation.

INTENSITY AND QUANTITY OF THE GROVE, DANIELL, AND SMEE BATTERIES.

The following facts have been determined relative to the comparative intensity and quantity powers of the Grove, Daniell and Smee batteries:

Intensity.	Quantity.		
Grove	87	Grove	44
Daniell	43½	Daniell	12
Smee, No. 1, open.....	27½	Smee, No. 1, open.....	42
Smee, approximated plates...	32	Smee, approximated plates..	49

Thus, it appears, that nearly equal quantities of electricity are excited by equal surfaces of Grove's and Smee's batteries, but that the intensity of the nitric acid battery, is rather more than three times that of Smee's. Daniell's arrangement holds an intermediate position with regard to intensity, but is deficient in quantity.

MAGNETISM.

CHAPTER VII.

Native Magnetism of the Load-Stone—Attractive and Repulsive Forces of Permanent Magnets—Component parts of the Magnet—Induced Magnetism.

NATIVE MAGNETISM OF THE LOAD-STONE.

As a preliminary to the consideration of electro-magnetism, it is necessary to explain the mysterious existence of the attractive and repulsive nature of matter commonly known as permanent magnetism. This is the more necessary as some of the telegraph systems have, as parts thereof, the conjunctive force of permanent and electro-magnetism.

Fig. 1 represents the native load-stone, found in the earth in different parts of the world. In the figure, the polarity of the stone is shown and its attractive force, by nails suspended by it.

It is an ore of iron, compounded of iron and oxygen. Recently, I saw large quantities of this ore near St. Louis, Missouri. It was in a mountain of iron. The discovery of the load-stone has been attributed to a shepherd, named Magnes, who observed its attraction to his iron crook, when tending his flock on Mount Ida, and from whom it is supposed the name of magnet is derived; though, according to other accounts, the load-stone first came from Heraclæa, in Magnesia, and one of its ancient names was *lapis*

Fig. 1.

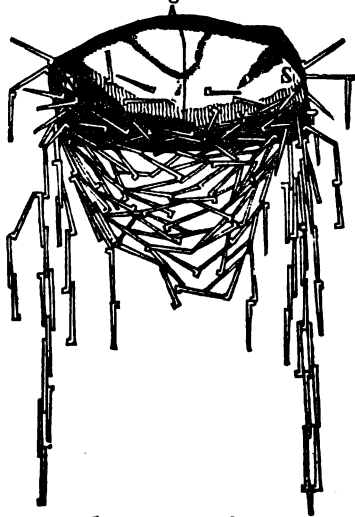

Heraclæus. Plato and Euripides called it the Herculean stone, because it commanded iron, the strongest of all metals.

VARIATION OF THE NEEDLE DISCOVERED BY COLUMBUS.

To what extent the earth is filled with the load-stone no one can form any idea. In connection with this, may be considered the magnetic polarity of the earth, and the magnetic or mariners' needle. The needle has been used for several centuries, but the variation of the compass needle, in different latitudes, was first noticed by the discoverer of America. Irving's Columbus says, viz.: "On the 13th of September, 1492, he perceived about nightfall that the needle, instead of pointing to the north star, varied but half a point, or between five and six degrees, to the northwest, and still more on the following morning. Struck with this circumstance, he observed it attentively for three days, and found that the variation increased as he advanced. He at first made no mention of this phenomenon, knowing how ready his people were to take alarm; but it soon attracted the attention of the pilots, and filled them with consternation. It seemed as if the laws of nature were changing as they advanced, and that they were entering into another world, subject to unknown influences. They apprehended that the compass was about to lose its mysterious virtues; and without this guide, what was to become of them in a vast and trackless ocean? Columbus tasked his science and ingenuity for reasons in which to allay their terrors. He told them that the direction of the needle was not to the polar star, but to some fixed invisible point. The variation was not caused by any failing in the compass, which, like the other heavenly bodies, had its changes and revolutions, and every day described a circle around the pole. The high opinion that the pilots entertained of Columbus as a profound astronomer, gave weight to his theory, and their alarm subsided."

THE FORCES OF PERMANENT MAGNETS.

Fig. 2.

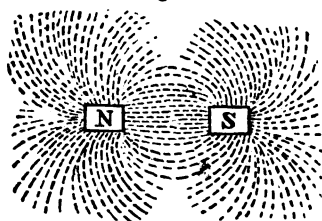

Place the ends of a magnet under a piece of paper on which are scattered some iron filings; in a moment the filings will be seen to arrange themselves in curves, as represented in figure 2; the greater part of the filings being collected over each end of the magnet, and spreading out in curvilinear directions toward the two ends. Very few of the

filings will collect on the spot over the centre of the magnet. When thus arranged, each one of the filings is magnetic, with distinct polarity, with attractive and repulsive powers, as the magnet beneath the paper. The magnetism in the particles, as to quantity, depends upon their respective proximities to the magnet poles. The farther they are from it, the less is their power. The curves formed are owing to the more distant attractive influence affecting them.

A straight permanent magnet is represented by figure 3. This form is called a compound permanent

Fig. 3.



magnet, because it is made of more than one bar, and it retains magnetism. By this uniting of several magnets, the power is increased. The similar poles of each must be placed together.

Fig 4 is a horseshoe or U-magnet. It is the bar magnet bent in the form represented in the figure, for the purpose of getting the attractive force of the two ends of the magnet to act at the same time upon the same matter. Figure 5 is the same as figure 4, compounded.

Fig. 4.



The two poles of the magnet are exercised in the attraction of the piece of iron Δ , which is called the keeper. It is called thus, because it aids to keep the magnetism in the bars. The moment that Δ comes in contact with the poles N and S , it becomes magnetic, with distinct polarities. The south pole of it, is next to the N , or north pole of the magnet.

Fig. 5.



The terms *north* and *south*, to indicate the polarity of the magnet, was given to the needle about the year 1600, conformably to the views entertained of terrestrial magnetism. The end of the needle that pointed toward the north was called the *south* pole, and that toward the south was called the *north* pole. The poles of the earth were supposed to be magnetic, and that the needle was affected by them, upon the principles of the present known laws, concerning the attractive and repulsive nature of magnets. Like poles repel, and opposite poles attract. The north pole of one magnet attracts the south pole of the other.

In examining the distribution of electricity, in a circular plane, it was found that the thickness of the electric stratum was almost constant from the centre, to within a very small distance of the circumference, when it increased all on a sud-

den with great rapidity. It has been believed that a similar distribution of magnetism took place in the transverse section of a magnetic bar; and by a series of magnetic experiments, results have induced some philosophers to believe that the magnetic power resides on the surface of iron bodies, and is entirely independent of their mass. On the other hand some are of the opinion that the magnetic force commences as a focus at the centre of the mass, and fully culminates at the surface.

COMPONENT PARTS OF THE MAGNET.

A magnet is considered as composed of minute invisible particles or filaments of iron, each of which has individually the properties of a separate magnet. It is assumed that there are two distinct fluids—the *austral* and *boreal*; and under the influence of either in a *free* state, the bar of iron or other metal will point to the north or south poles of the earth, according to circumstances. It is within these small particles or metallic elements that the displacement or separation of the two attractive powers take place; and the particles may be the ultimate atoms of iron. A magnetic bar may, therefore, as represented in figure 6, be composed of minute portions, the right hand extremities of each of which possess one species of magnetism, and the left hand extremities the other species; the shaded ends being supposed to possess *boreal*, and the light end *austral* magnetism. The ends of the bar, when either straight or U shaped, are charged with boreal or austral magnetism, and the ends are called by those respective terms. More commonly the ends of the magnet are called the “north” and “south” poles, for the reasons before mentioned.

Fig. 6.

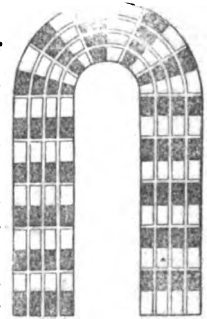

These fluids exist in a combined state, and in certain proportions they are united to each molecule or atom of the metal, from which they can never be disunited except by their decomposition into separate fluids, one of which in a permanent magnet is always collected on one, and the other on the opposite side of each molecule.

INDUCED MAGNETISM.

In order to communicate magnetism from a natural or artificial magnet, to unmagnetized iron or steel, it is not necessary that the two bodies should be in contact. The communica-

tion is effected as perfectly, though more feebly, when the bodies are separated by space.

Figure 7 represents a bar, magnet *M*, and an iron rod *B*, near together. By the

Fig. 7.



influence of the magnet *M* upon the principles of induction, the rod *B* partakes of the magnetism of *M*, the end *N* becoming *boreal* and the end *S* *austral*. If the rod *B* be brought in contact with the bar *M*, the induction will be much stronger.

If to the north pole (fig. 8) of an artificial steel magnet *A*, is placed a soft iron bar, *B*, the end *S* of *B* will instantly acquire the properties of a *south* pole, and the opposite end *N*, those of the north pole.

Fig. 8.

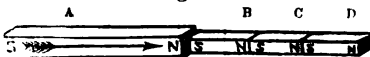

The opposite poles would have been produced at *N* and *S*, if the south pole *S* of the magnet *A*, had been placed near the iron *B*. In like manner, the piece of soft iron *B*, though only temporarily magnetic, will render another piece of iron, *C*, and this again another piece, *D*, temporarily magnetic, north and south poles being produced at the ends. This represents compound induction.

It is important for the reader to observe the pointed analogy between the phenomena of magnetic attraction and repulsion, and those of electricity. In both there exists the same character of double agencies of opposite kind, capable, when separate, of acting with great energy, and being, when combined together, perfectly neutralized, and exhibiting no signs of activity. As there are two electrical, so there are also two magnetic powers; and both sets of phenomena are governed by the same characteristic laws. So also in the last experiment, the magnetism inherent in *B*, *C*, *D*, is said to be *induced* by the presence of the real magnet; and the phenomena are exactly analogous to the communication of electricity to unelectrified bodies by induction, the positive state inducing the negative, and the negative the positive, in the parts of a conductor placed in a state of insulation, near an electrified body. Where two or more wires are suspended on the same set of poles, the voltaic current transmitted on one wire will escape to the other wire by induction, though not to a very great extent. If the wires are placed near together, more or less of the electric influence will pass from one to the other. Figure 9 is another representation of the inductive principle. Plunge a U-magnet into a cask of nails and on withdrawing it the nails will adhere to the magnet and to each other as represented in the figure. If the magnet be placed in connection with iron filings, they will collect on the poles as seen in figure 10.

If the north pole of a bar magnet, figure 11, be placed on the centre of a circular plate of iron, a south polarity is given

Fig. 9.

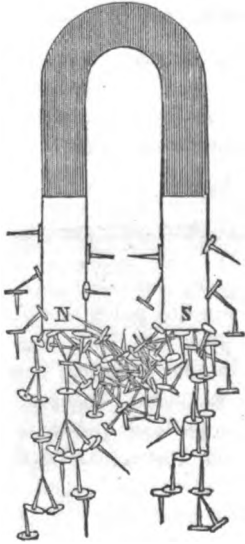

Fig. 10.

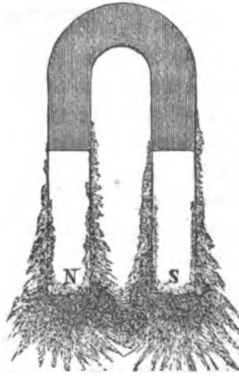

Fig. 11.

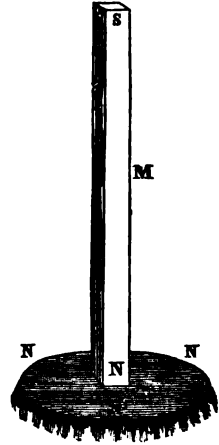

Fig. 12.

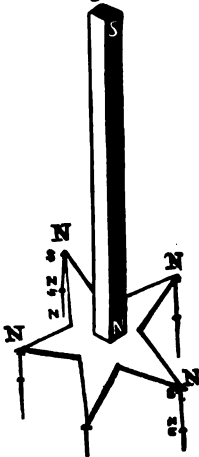
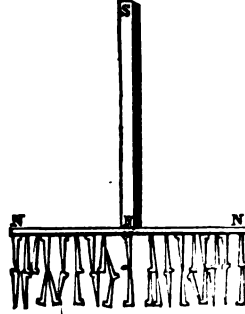

Fig. 13.



to the metal or plate touching the bar, and the under part becomes north, and from it will be suspended iron filings when they are brought in contact with the plate. If the plate is cut in the form of a star, as represented by figure 12, each point becomes a stronger north pole. The part of the plate in con-

tact with the bar is south, and the line of induction extends to the points. If nails be suspended from the points the polarity of the respective pieces will be as represented in the figure.

If the north pole be placed on the middle of the bar of iron, as seen in figure 13, the part of the horizontal bar becomes a south pole, and the respective ends become north. The bar $n n$ becomes magnetically two pieces of iron, each with its south pole terminating at the bar $s n$. If pieces of iron wire of equal lengths be suspended from a magnetic pole, they will not hang parallel. The lower ends will diverge from each other in consequence of their having the same polarity, as seen by figure 13.

If a bar magnet be broken into two pieces the polarity of each piece will at once be formed as seen by figure 14. These halves may be broken with the same result, each section having a full charge of the magnetic influence.

The magnetic needle is a very slender magnet mounted on a pivot, as seen in figure 15, or it may be otherwise suspended.

Fig. 14.



Fig. 15.

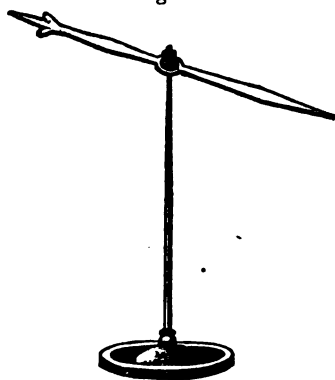

Fig. 16.

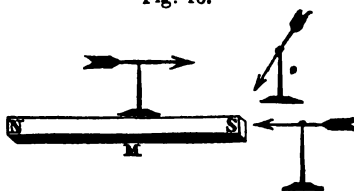
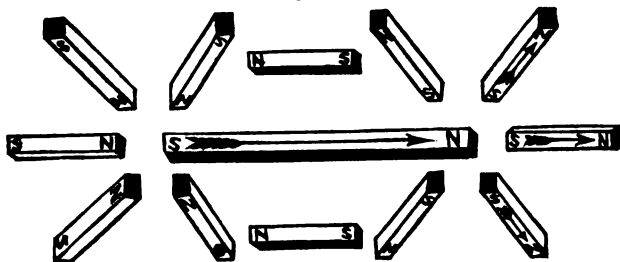
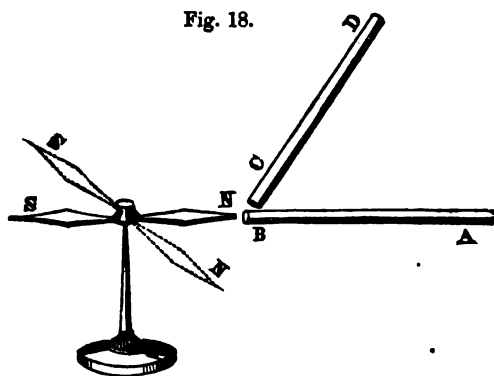

Fig. 17.



One end of the needle is north and the other end is south. Figure 16 represents a bar magnet, and the three needles or arrows, indicate the direction of the magnetic force. The arrow-heads are of north polarity, and the two to the right are influenced by the south polarity of the magnet bar *n s*. The south pole of the bar and the north poles of the needles attract each other. The needle over the centre of the bar magnet is equally influenced by the polarity of the bar *n s*, and it cannot deviate from a parallel. Figure 17 represents the different positions necessary to place magnets to make them harmonize in their respective influences or forces one with the other. If the various small pieces were arrows, their polarities would be as represented in figure 17, conjunctively with the larger magnet in the centre.

An unmagnetized bar, suspended in the direction of north and south, formed as figure 15, will assume temporary magnetism inductively from the earth. The end of the suspended rod directed toward the north pole, becomes south, and the end toward the south will receive north polarity. Figure 18 represents a bar of iron, *A B*, placed in a horizontal position to the



north pole of a magnetic needle, *n s*. The pole as thus placed is attracted by the bar. Keeping the end *B* in the same place, raise the end *A* so as to bring the bar into the position *C D*. As the bar is raised, the north pole recedes from *C*, as indicated by the dotted lines in the figure. The strongest action is exerted when the bar is in the line of the dip, or in this latitude, nearly vertically over the needle. Change the positions of the bar, and the needle will be changed. By this experiment the reader will find that the bar of iron has become polarized with magnetism.

Figure 19 represents the charging of a bar of iron by percussion. Hold the bar in the line of the dip, and its lower end brought near to the north pole of a magnetic needle. In consequence of the polarity of the iron, received from the earth, the needle will slightly swing from its normal position. Strike the end of the iron rod with a hammer, and immediately the magnetic force in the bar becomes greatly increased, and the needle swings to the bar as seen in the figure, the south pole of the needle to the north pole of the bar.

Fig. 19.

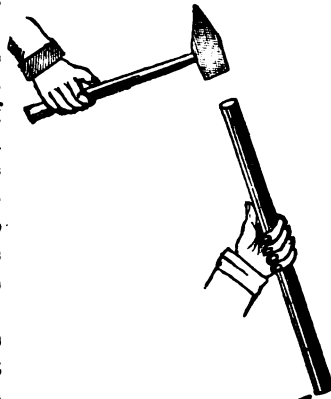

Take a piece of iron wire, place it in a vertical position, and twist it powerfully. The twist will be seen to sustain iron filings as seen by figure 20. This is very often seen by the telegrapher when making joints in the wire. Balance the twist on a pivot, and it will at once assume polarity. The end which was downward becomes the north pole. The telegrapher will observe, when filing the wire to make the joints, filings adhere to the ends of the wire. This magnetism is produced upon the principles of percussion.

Fig. 20.

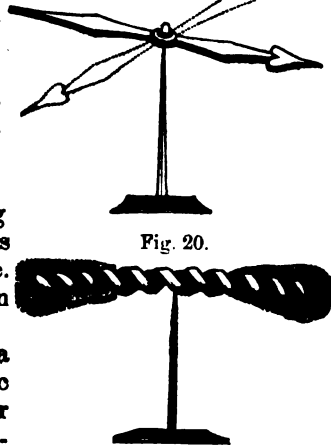

I have thus briefly presented a few explanations of the magnetic force imparted to metals, and for further and more detailed information the reader can refer to the standard works on electrical and magnetic phenomena.

ELECTRO - MAGNETISM.

CHAPTER VIII.

Discovery of Electro-Magnetism by Ørsted—Discoveries of Schweigger, Arago, and Ampère—Discoveries of Sturgeon and Henry—Recapitulation of the Discoveries on Electro-Magnetism—English Telegraph Electrometers—Magnetometers—The De La Rive Ring, and other Experiments.

DISCOVERY OF ELECTRO-MAGNETISM BY ØRSTED.

THE art of the electric telegraph is based upon the science of electro-magnetism. The brilliant discovery of this science was made in the year 1819, by Professor Christian Ørsted, of Copenhagen.

In the year 1854, I visited Copenhagen, and the first object of my curiosity was to see the laboratory of Ørsted. Through the generous attention of M. Faber, the director-general of the telegraphs of Denmark, my desire was gratified. I saw the room in which electro-magnetism was discovered, and the small compass that developed it.

Professor Ørsted was engaged in arranging some wires connected with the voltaic battery, preparatory to making some electrical experiments which he had in view. While thus adjusting the wire conductor, he had in his hand a small compass, some two and a half inches in diameter. Sometimes his hand, with the compass, was above the wires, and at other times below them. He observed the needle of the compass to move, and his attention being once directed to the development, the discovery followed as a sequence. That discovery, at the time, was made known in the following language, viz. : "When a magnetic needle is properly poised on its pivot at rest in the magnetic meridian, and a wire arranged over and parallel to the needle, in the same vertical plane, and the ends of the wire made to communicate, respectively, with the poles of a voltaic battery, the needle will be deflected."

This was the simple announcement, giving the whole of the discovery. It was enough to immortalize Ørsted.

Fig. 1 represents the discovery made by Ørsted, excepting the needle $s n$ is poised upon an exposed pivot, instead of being enclosed in a brass compass case. If the wire charged with an electric current is placed horizontally *over* the compass needle, the pole of the needle which is nearest to the *negative* end of the battery always moves *westward*: if it be placed *under*, the same pole moves to the east. If the wire be parallel with the needle, that is, brought into the same horizontal plane in which the needle is moving, then no motion of the needle in that plane takes place, but a tendency is exhibited in it to move in a vertical circle, the pole nearest the *negative* side of the battery being depressed when the wire is to the *west* of it, and elevated when placed on the *eastern* side.

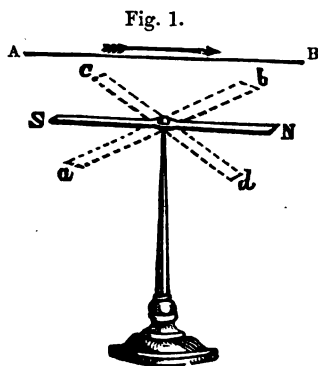

In the example given by the figure, the current is flowing on the wire north and south, from A to B . The needle $s n$ deflects from the parallel line, and the north pole of the needle will turn to the west, and if it be below the wire, it will turn to the east to the extent, respectively, as represented by the dotted lines $a b$ and $c d$ in the figure.

The force exerted by the electric current on the magnetized needle diminishes in intensity in proportion as the distance between the current and the needle increases. It has been determined, as a law, that when the current is rectilinear, and the length of the wire considerable, so that in relation to that of the needle, it may be regarded as infinite, the intensity of the electro-magnetic force is *in inverse ratio to the simple distance of the thing magnetized from the current*.

DISCOVERIES OF SCHWEIGGER, ARAGO, AND AMPERE.

Immediately after the discovery of Ørsted, which was made in 1819, and published in 1820, M. Schweigger discovered that the surrounding of a needle with many coils of wire increased the deflecting power of the voltaic current. This improvement was announced in the German "Literary Gazette," November, 1820, No. 296. Since that time the arrangement of circling the wire around a magnetized needle has been called

"Schweigger's multiplier," because it multiplied the power of the deflection. Take a small compass, about two and a half inches in diameter, and then wind around it—in the course or direction of the needle, north and south—fine insulated wire. The turns may be two or a hundred, and the principle will be the same. Transmit through the wire thus wound round the compass, and the needle will rapidly leave its north and south positions, and, if the current be strong enough, it will assume the east and west directions. Reverse the current through the wire, and the needle will immediately change its position and point in the opposite direction to that first assumed. Remove the current from the wire, and the needle will immediately take its normal, or north and south position.

In the year 1820, M. Arago, of France, found that if the wire which connects the two extremities of a voltaic battery be plunged into fine iron filings, a considerable portion of them will be attracted, and will remain attached to the wire as long as the current continues to circulate

Fig. 2.

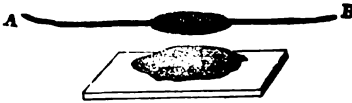

through it; on breaking the circuit, the filings will immediately drop off. If small steel needles be laid across the wire, they will be attracted, and on removing them they will be found to be permanently magnetized.

In the year 1820, Ampère, of France, made some important experiments, and he found that two wires, through which voltaic currents were passing in the same direction, attracted, and in the opposite direction repelled, each other. Upon the theories of Ampère, Arago adopted the method of magnetizing needles. He placed in a glass tube a needle, and wound around the tube a wire composing a part of the voltaic circuit; the needle was magnetized. He also found that the polarity of the needle, as a magnet, depended upon the direction of the current around the glass tube. If a right-handed spiral, the

Fig. 8.



boreal pole would be formed at the end at which the current entered, that is, the positive end; if a left-handed helix, the bar acquired an austral polarity. The wire was wound around the glass tube, so that its spirals would not touch. In the glass tube was laid an ordinary sewing needle.

DISCOVERIES OF STURGEON AND HENRY.

The next grand step taken in the science of electro-magnetism was by Sturgeon in 1825. He bent a piece of iron wire in the form of a horse-shoe. He then insulated the iron wire, bent as a horse-shoe, by covering it with varnish; and having thus covered the iron to be magnetized, he wound around it a copper wire, and placed the spirals so that they would not touch, in order to prevent the current from passing from one spiral to the other without circulating around the iron.

The result was a complete success. The ends of the bent iron wire were found to be magnetic when the current was on the spiral wire; and when off, it was not magnetic. This experiment was an advance of Arago and Ampère. Fig. 4 represents the plan adopted by Sturgeon. It is an exact copy of the original drawing published in the "Annals of Philosophy," 1826.

Upon the theory advanced by Ampère, Arago coiled wire around the glass tube to magnetize the needles; Sturgeon, instead of using the glass tube to insulate the electric copper wire from the iron core to be magnetized, used varnish as an insulator. It was a non-conductor, and separated the electric wire from the iron. Besides the improvement in the idea of the insulation, he bent the wire in the form of a u, which was a very important progress from the straight bar or needle.

Professor Joseph Henry, of America, in his philosophical researches, in 1828, continued in 1829 and 1830, was led to

Fig. 4.

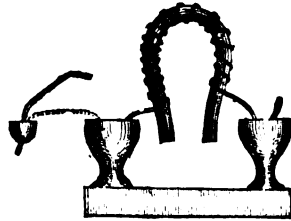

Fig. 5.

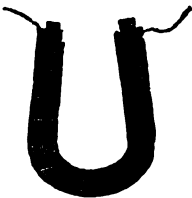
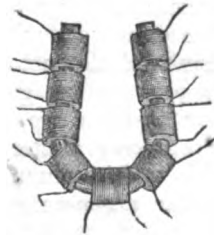

Fig. 6.



make farther advances, and he perfected the construction of the electro-magnet as now known in the science. He con-

ceived the idea of covering or insulating the wire, instead of covering or insulating the iron to be magnetized, as had been done by others. He effected this by insulating a long wire with silk thread, and winding this around the rod of iron in close coils, as is seen in fig. 5, from one end to the other. The same principle was extended by employing a still longer insulated wire, and winding several strata of this over the first, care being taken to insure the insulation between each stratum by a covering of silk ribbon. By this arrangement the rod was surrounded by a compound helix, formed of many coils, instead of a single helix of a few coils.

In the peculiar arrangement of the coils, Professor Henry advanced new ideas. Arago and Sturgeon wound their wires not precisely at right angles to the axis of the rod, as they should have been, to produce the effect required by the theory of Ampère, but they were placed obliquely around the rod to be magnetized; therefore, each turn tended to develop a separate magnetism not coincident with the axis of the bar. In winding the wire over itself, as done by Henry, the obliquity of the several turns compensated each other, and the resultant action was at right angles to the bar. The ends attained by Henry were of the greatest importance. The multiplied turns of the wire, and their peculiar conjunctive action in the generation of magnetic force in the iron rod, were complete in success. He found that, after a certain length of wire had been coiled upon the iron, the power diminished with a further increase of the number of turns. This was due to the increased resistance which the longer wire offered to the conduction of electricity. As an improvement, he increased the number of independent coils around the u shaped rod, as represented by fig. 6. Another was to increase the number of cells of the battery to obtain a current of greater intensity, for the purpose of overcoming the increased length of the wire, so as to produce or develop the maximum power of the iron. Fig. 6 represents the manner of coiling around the iron bar the insulated wire in several independent sections. Each of these sections was united with a Cruikshank voltaic battery. The experiment proved, that, in order to produce the greatest amount of magnetism from a battery of a single cup, a number of helices is required; but when a compound battery is used, then one long wire must be employed, making many turns around the iron core. The magnetic force generated, will be commensurate with the projectile power of the battery.

In describing the results of these experiments, Professor Henry has used the terms *intensity* and *quantity* magnets.

By the former is meant, that when a piece of soft iron, so surrounded with wire that its magnetic power could be called into operation by an *intensity* battery, the magnet was called an "*intensity* magnet;" when it was acted upon by a *quantity* battery through a number of separate coils, so that its magnetism could be fully developed, it was called a "*quantity* magnet." The terms are technical, and very appropriate.

Fig. 7 represents the Sturgeon magnet, A, and the Henry magnet, B.

Around the former (A) are wound the spirals apart from each other—the iron core being insulated, and the copper wire not insulated. Around the latter, B, the wire is insulated with silk thread, and the coils are multiplied. This was the magnet invented by

Fig. 7.

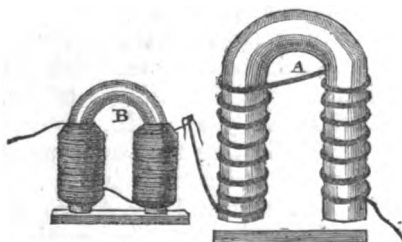

Henry, and which at the time astonished the scientific world. With the same battery, at least a hundred times more magnetism was produced by Henry's magnet than could have been obtained by Sturgeon's magnet. The developments were considered at the time of much importance in a scientific point of view, and they subsequently furnished the means by which magneto-electricity, the phenomena of dia-magnetism, and the magnetic effects on polarized light, were discovered. They gave rise to the various forms of electro-magnetic machines which have since distinguished the age. Upon Henry's electro-magnet are based the various electro-magnetic telegraphs.

The following may be considered as laws relative to electro-magnetism :

1st. The magnetic force developed in the iron is in proportion to the quantity and intensity of the current.

2d. The force, if the current be equal, is independent of the thickness of the wire or shape of the iron.

3d. Within certain limits, in a continuous coil wound in layers, like a spool or bobbin of silk, the external turns are as efficacious as those close to the iron.

4th. The total action of the spiral is equal to the sum of the actions of each turn.

Thus, by increasing the force of the battery so that its intensity is augmented twofold, threefold, fourfold, the force of the electro-magnet increases in the same degree. Of course this force will find its maximum in the conductivity of the metal employed in the voltaic circuit.

RECAPITULATION OF THE DISCOVERIES OF ELECTRO-MAGNETISM.

The discoveries of Henry were published to the world in 1831, and were the subject of discussion among scientific men on both continents. Since then there has not been any advance in the principles pertaining to the organization of the electro-magnet. Mechanically, it has been brought to a smaller size and made more convenient for the purposes of its use.

From the preceding it will be seen that the following are the facts relative to the progress of electro-magnetism :

1st. In the year 1819, CErsted discovered that a magnetic needle would be deflected when situated near a wire charged with a current of voltaic electricity.

2d. In the year 1820, Schweigger discovered that the power of deflecting the needle would be increased by surrounding it with the electric wire.

3d. In the year 1820, Arago and Ampère coiled around a glass tube, and magnetized sewing needles placed in the tube.

4th. In the year 1826, Sturgeon insulated an iron wire bent like a horse-shoe, and then wound around it a copper wire. When a current of electricity was sent through the copper wire the insulated iron wire was magnetized.

5th. In the years 1828, '29, and '30, Henry wound an insulated copper wire around an uninsulated iron rod, shaped like a horse-shoe. He passed a current of electricity through the copper wire, and the bent iron rod was magnetized.

6th. In the same years Henry increased the convolutions of the insulated copper wire, and on passing a current of electricity through the copper wire, the magnetic power of the bent iron rod was greatly increased.

The above presents the true state of the science of electro-magnetism before the invention of the electro-magnetic telegraph, of either continent, as none of them can date earlier than 1832. Without the discoveries above described, made by Sturgeon and Henry, the electro-magnetic telegraph would still be in the womb of time, awaiting the allotted hour for its birth—distinguishing, for aught we know, a generation yet unborn, instead of, as it has done with singular grandeur, "the age in which we live."

Fig. 8 represents the magnet as applied in the telegraph. The wire is insulated with silk, and wound around the iron bar. Fig. 9 is another form adopted in the making of the magnet. The insulated silk wire is wound around hard rubber spools, and the U-shaped iron is moveable. One of the advantages in the use of the moveable cores consists in the

facility of demagnetizing them when charged with permanent magnetism.

The attention of the student of telegraphing should be

Fig. 8.

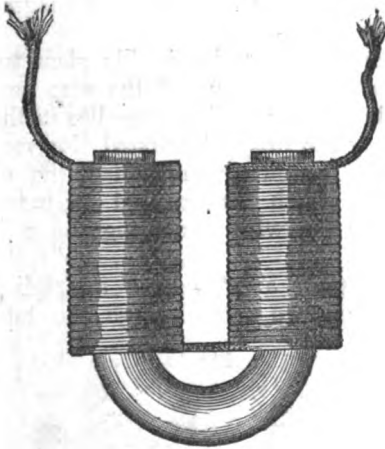

directed to the proper arrangement of the wire around the cores. The wire should be well insulated, wound as regular as possible, and in the direction indicated by the preceding

Fig. 9.

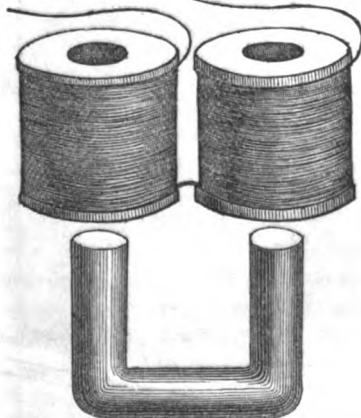

figures. I once knew the working of a station to be hindered by the operator re-winding his wire, so that the magnetism could not be imparted to the iron. The arms should be wound, as represented by fig. 7.

ENGLISH TELEGRAPH ELECTROMETERS.

The English electric telegraphs are organized upon the principle of Schweigger's multiplier, and so true is this, that Mr. Cooke in the invention of the first needle telegraph adopted the multiplier.

Arago used ordinary needles in his glass tubes, and they were magnetized by the coiling of the wire around the tubes, but the principle in the use of the needles in the English telegraph is precisely the original $\text{\O}rsted$ discovery, as extended by Schweigger. The latter multiplied the coils around a magnetic needle, which was caused to move, as seen by $\text{\O}rsted$, whenever the wire composing the coils was charged with electricity.

Figure 10 represents a Schweigger multiplier improved by mechanism; $i k$ are two coils, through the interior of which

Fig. 10.

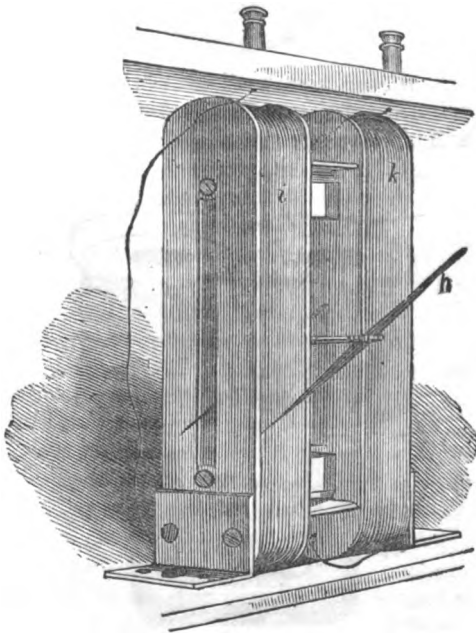

swing a magnetized needle. When the current traverses the coils, the needle changes its position from a perpendicular to a horizontal, or to the extent influenced by the current. The

exterior needle *h* may be magnetic, or it may not be. It is

Fig. 11.

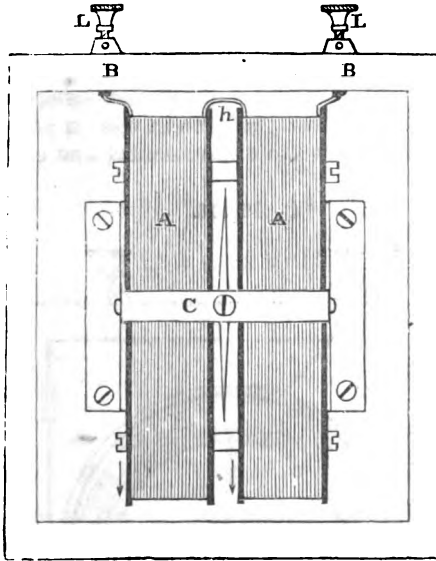
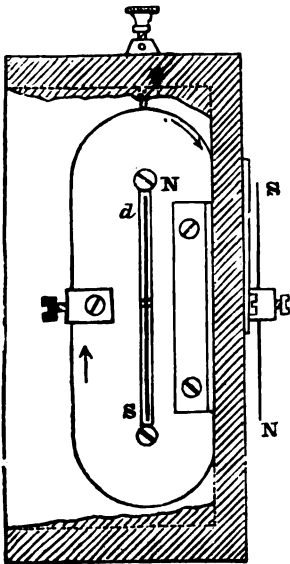

Fig. 12.



often made of light material, so as to easily swing upon the same axle with the interior needle. This instrument is called an "Electrometer."

Another view of the electrometer is represented by fig. 11, showing the coils *A A* and the needle suspended between them. *L L* are binding screws fastened to the frame *B B*. The line wires are fastened to *L L*. *c* is a brace band to hold the coils of fine wire *A A*. The arrows indicate the route of the voltaic current. Fig. 12 represents a side view of the same instrument. To the right is seen the needle and its polarity *s n*; in the interior is seen the other magnetic needle and its polarity *n s*; the arrows indicate the route of the voltaic current.

Fig. 13 represents the face of the electrometer used in nearly all the European telegraph stations. This is a small box about five inches square, with a glass cover. The index finger acts co-operative with the needle suspended between the coils, and its movement to the right or to the left indicates the quantity of the current and its polarity, whether negative or positive. It would be a useful instrument on the American lines. At this time, there is, perhaps, not one in use on any of the lines, nor has there been since the experimental line of 1844.

Fig. 18.

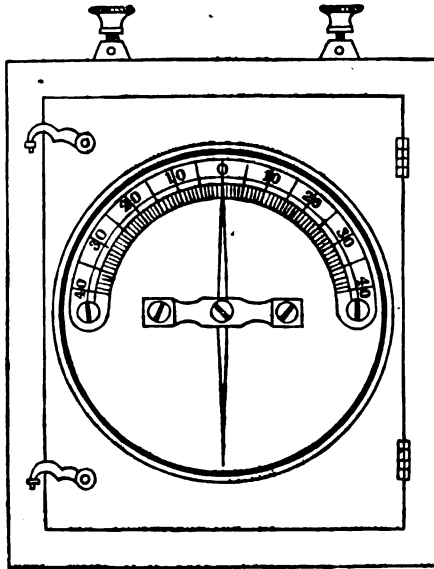

ELECTROMETERS GENERALLY.

Fig. 14 represents another form of an electrometer. The wire is wound around a frame not given in the figure. The needle *n s* rests upon a pivot on the stand *c d*. The battery wires are fastened at the binding posts *A B*, which connect with wires near *c d* respectively. The wire is wound upon the same principle as in the making of the magnets hereinbefore mentioned. When the electricity passes around the coil, the needle moves to the right or to the left, according to the course of the current.

Fig. 15 represents an upright electrometer. The principle

of this instrument is precisely the same as the one above

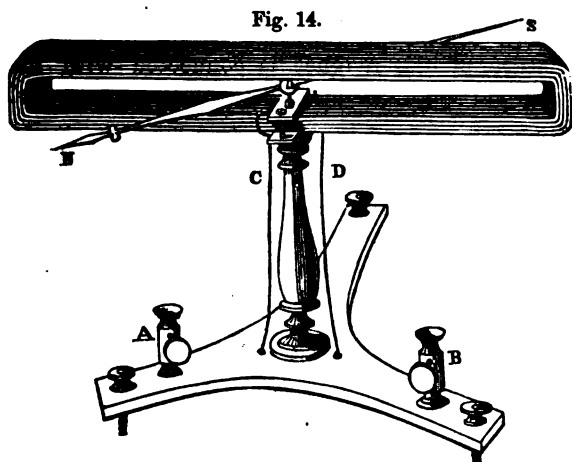
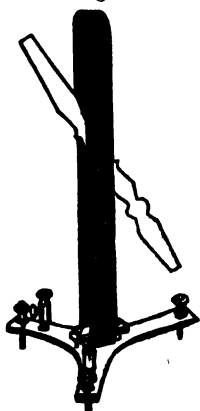

Fig. 15.



described. It is nearer the simple multiplier devised by Schweigger.

Fig. 16 represents the compass form electrometer. The coil of wire is made to surround an ordinary pocket compass, and the strength of the electric current is measured by the deflection of the needle. The circle is divided into divisions as minute as may be required for the purposes of its use. It is a very convenient instrument, and will be useful in the practice of telegraphing.

Fig. 17 represents the most delicate form of electrometer. It is capable of being influenced by the slightest presence of electricity. On the base are placed two coils of wire, as represented by fig. 10, between which is suspended a delicate magnetic needle, with its mate or index needle above a dial plate. The needle is suspended by a cocoon thread from the top. Over the whole is placed a glass cover. If there is any electricity in the coils, the index needle will exhibit it and the quantity.

MAGNETOMETERS.

Various contrivances have been made to measure the magnetic force of electro-magnets. Fig. 18 is one gotten up by

Mr. Charles T. Chester, of New-York, as an attachment to the electro-magnet used on the Morse telegraph. The ends of the coils are seen below; the measurement scale is seen above. The armature of the magnet is connected with the index finger, and the slightest magnetic influence will be exhibited.

Fig. 19 represents Hearder's magnetometer. *AB* is a strong base of wood, about four feet long and one foot wide, to which are attached four levelling screws; *DD* are two strong iron uprights, firmly screwed into the base and connected at the top by a stout iron cross piece, *E*, having a hole in the centre, through which passes the screw, *F*, of the strong double sus-

Fig. 16.

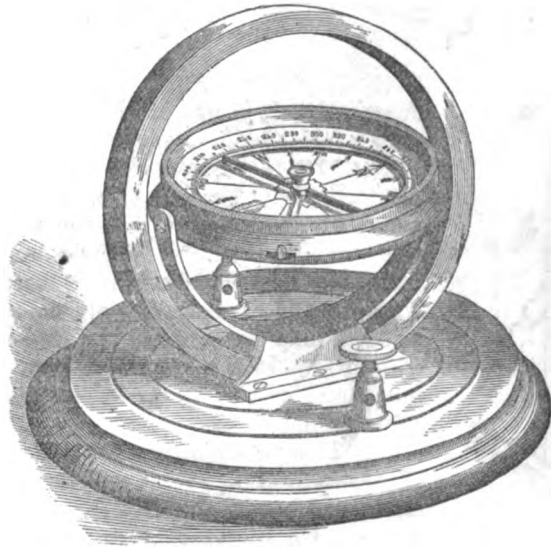

pension hook *G*. Two iron nuts, *HH*, serve to fix the suspension hook at any height. *II* is a light and delicate, but strong steel yard, being graduated on one side to correspond with the distance between the knife-edge *K* and *M*; these are respectively one and two inches apart. Different weights may be employed; on the arm *N* is a rest to support the long arm of the lever, and it is capable of being adjusted to any height by a tightening screw in the hollow socket *O*. The different parts of the scale are marked by letters, each of which will be readily understood by the reader. The magnet, *UV*, is wound with

the conducting or electric wire; this arrangement will give the strength of the magnetic force. It can be made upon any

Fig. 17.

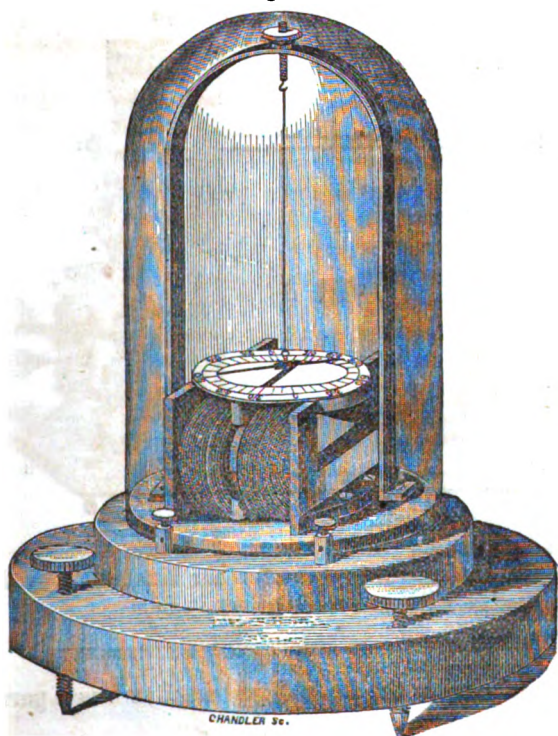
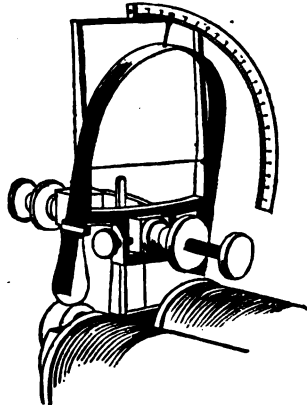
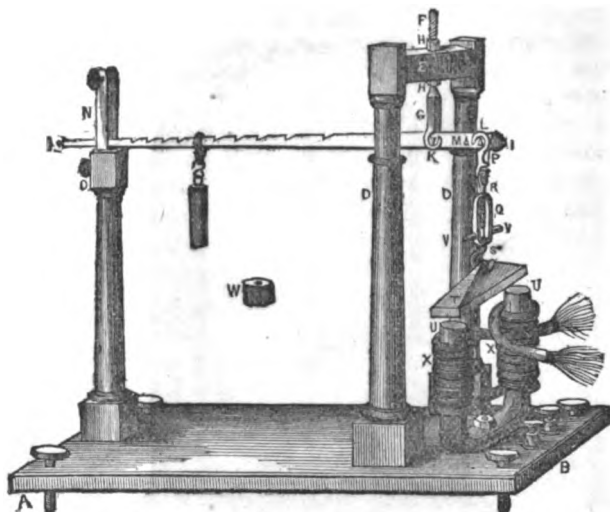

Fig. 18.



required scale, and its application in testing the strength of the magnets for telegraphic purposes might subserve a good end.

Fig. 19.



Before concluding this chapter, I desire to notice a few experiments, having in view the further illustration of the relative forces, electricity and magnetism

DE-LA-RIVE RING AND OTHER EXPERIMENTS.

Fig. 20 represents the De-la-Rive ring. s N is a permanent

Fig. 20.

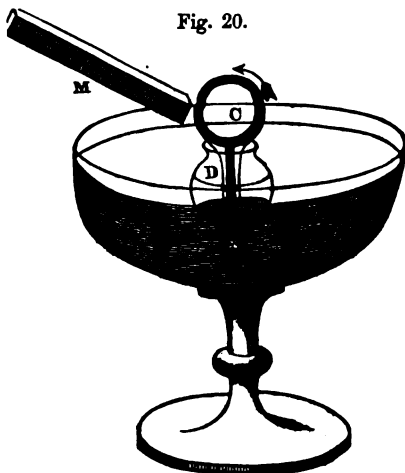

magnet; *c* is a coil of wire fastened to zinc and copper pieces, which are placed in a vessel of acid. An electric current is generated, and traverses the coil *c*, as indicated by the arrow. The vessel *d*, with the coil *c*, floats in a bowl of water. When the magnet *m* is placed near the bowl, the ring *c* will be repelled or attracted, according to the polarity of the magnet directed toward the ring—the electric coil moves from or to the more powerful permanent magnet.

Fig. 21 represents a spiral wire suspended. The lower end is connected with a mercury cup. A current of electricity is made to traverse the spiral. In fig. 22 a permanent magnet is placed in the spiral. The moment the magnet is thus placed,

Fig. 21.

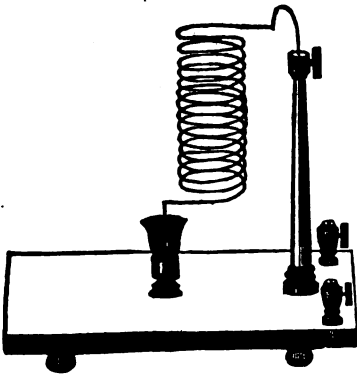
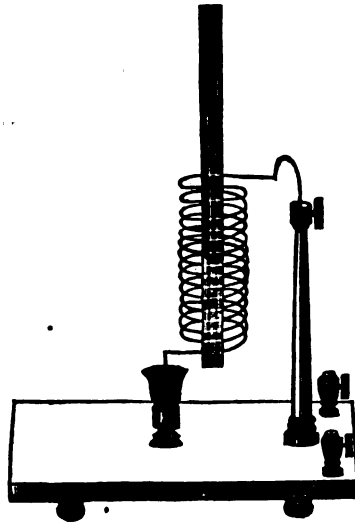

Fig. 22.



the spiral wire will move up and down, opening and closing the circuit in the mercury cup. If the battery is strong, a blue flame will be made when the wires come in contact with the mercury.

Fig. 23 represents the mode of communicating permanent magnetism to a steel bar by an electro-magnet. *ns* is a steel bar, which is drawn from the bend to the extremities across the poles of the electro-magnet in such a way, that both halves of the bar may pass at the same time over the poles to which they are applied.

Fig. 24 represents the principle of axial magnetism, invented

by Professor Charles G. Page, of America. For the purpose of explaining the principle, the following will suffice. The coil consists of a number of layers of wire, and has a small central opening. An iron bar passed within it becomes strongly magnetic. When the coil is in a vertical position, the iron bar is sustained within it in consequence of the force with which it is

Fig. 23.

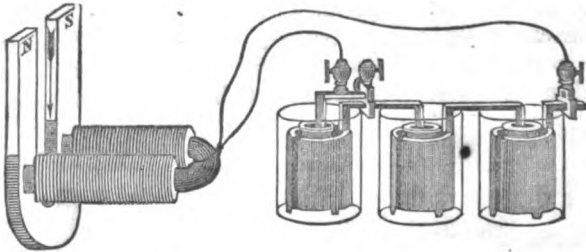

drawn toward the middle of the coil. With a large battery, a considerable weight may be suspended from the bar without any visible support. The action of the coil is the same, except in the amount, as that of a single circular turn of wire. At any two points of the circle, diametrically opposite, the direc-

Fig. 24.

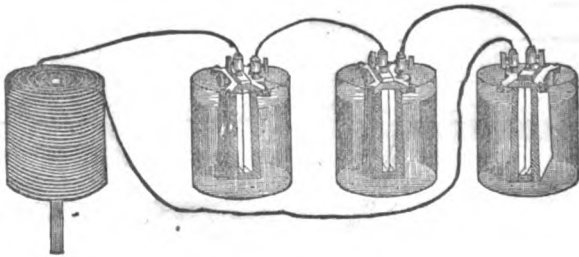

tions of the current are also opposite. The resultant of the forces exerted by all the points, tends to bring the centre of the magnetized bar within the circle. The action of all the circles of which the helix is composed draws the bar into it, until its middle lies within the middle of the helix, in which position only can the forces neutralize each other. This is termed an "axial magnet."

The axial magnet performs an important part in the House telegraph, the particular construction of which I have fully described elsewhere in this work. The American apparatus is the only telegraph employing this species of magnetic action.

It has subserved the purposes of its introduction, and acts in beautiful harmony with other parts of that most wonderful and beautiful combination of mechanism.

It is due to the memory of the lamented Alfred Vail, to acknowledge that he rendered great service in the discovery of the phenomena of axial magnetism. He instituted a series of experiments, and promulgated many of them to the world.

EARLY ELECTRIC TELEGRAPHS.

CHAPTER IX.

Suggestions of Science—The Telegraph of Lomond—Reizen's and Dr. Salva's Electric Spark Telegraph—Baron Schilling's, Gauss and Weber's, and Alexander's Telegraphs.

SUGGESTIONS OF SCIENCE.

THE various discoveries in the sciences, made from time to time, developed the idea of an electric telegraph. With many of the discoverers, nothing more was done by them toward the production of a practical telegraph, than suggesting to others the application of the sciences to the arts, which, in their opinion, would accomplish the great achievement. Philosophers dislike to vend to the world, commercially, their discoveries. They remove the coverings from the long-closed vaults containing the hidden treasures of a mysterious providence; and as soon as they catch a single gleam from the brilliancy of the gem, the world is informed of it. The myriads of discoveries of the present age compose a galaxy more brilliant in glory than those of any other century.

Among those who aided by developing science, suggestive of the telegraph, may be mentioned Prof. Henry, of America, who, in 1830, wrote an article, which was published in Silliman's Journal, in 1831, in which he stated "the fact, that the magnetic action of a current from a trough is, *at least*, not sensibly diminished by passing through a long wire, is directly applicable to Mr. Barlow's project of forming an Electro-Magnetic Telegraph, and also of material consequence in the construction of the galvanic coil." Ampère, Jacobi, Faraday, Sturgeon, and others, have also aided by their discoveries the perfection of the art of telegraphing, as now practically employed throughout the civilized world.

LOMOND'S ELECTRIC TELEGRAPH.

It is stated in Young's Travels in France (1787, 4th ed., vol. i. p. 79), that a Mr. Lomond had invented a mode by which,

from his own room, he held communication with a person in a neighboring chamber, by means of electricity. He employed the common electrical machine placed at one station, and at the other an electrometer constructed with pith balls. These instruments were connected by means of two wires stretched from one apartment to the other, so that, at each discharge of the Leyden vial, the pith-balls would recede from each other, until they came in contact with the return wire. His system of telegraphic correspondence is not related. We must suppose from the character of his invention, having but one movement, that of the divergence of the balls, and using an apparatus extremely delicate, that his means of communication could not have been otherwise than limited, and required a great amount of time.

The only mode in which it appears possible for him to have transmitted intelligence, seems to be this: a single divergence of the pith balls, succeeded by an interval of two or three seconds, may have represented A. Two divergences in quick succession, with an interval following, may have represented B; three divergences, in like manner, indicated the letter C; and so on for the remainder of the alphabet. Instead of these movements of the pith balls representing letters, they may have indicated the numerals 1, 2, 3, &c., so that with a vocabulary of words, numbered, conducted his correspondence. This appears to be the first electrical telegraph of which we have any account; but does not appear to have been used upon extended lines.

REIZEN'S ELECTRIC SPARK TELEGRAPH.

In 1794, according to Voigt's Magazine, vol. ix., p. 1, Reizen made use of the electric spark for telegraphic purposes. His plan was based upon the phenomenon which is observed when the electric fluid of a common machine is interrupted in its circuit by breakers in the wire, exhibiting at the interrupted portions of the circuit a bright spark. The spark thus rendered visible in its passage, he appears to have employed in this manner.

Fig. 1 is a representation of the table upon which were arranged the letters of the alphabet, twenty-six in number. Each letter is represented by strips of tin foil, passing from left to right, and right to left, alternately, over a space of an inch square upon a glass table. Such parts of the tin foil are cut out, as will represent a particular letter. Thus, it will be seen that the letter A is represented by those portions of the tin foil which have been taken out, and the remaining portions answer as the conductor. P and N represent the positive and negative

ends of the strips, as they pass through the table and reappear, one on each side of the small dot at A. Those two lines which have a dot between, are the ends of the negative and positive wires belonging to one of the letters. Now, if a spark from a charged receiver is sent through the wires belonging to letter A, that letter will present a bright and luminous appearance of the form of the letter A. "As the passage of the electric fluid through a perfect conductor is unattended with light, and as the light or spark appears only where imperfect conductors are thrown in its way, hence the appearance of the light at those

Fig. 1.

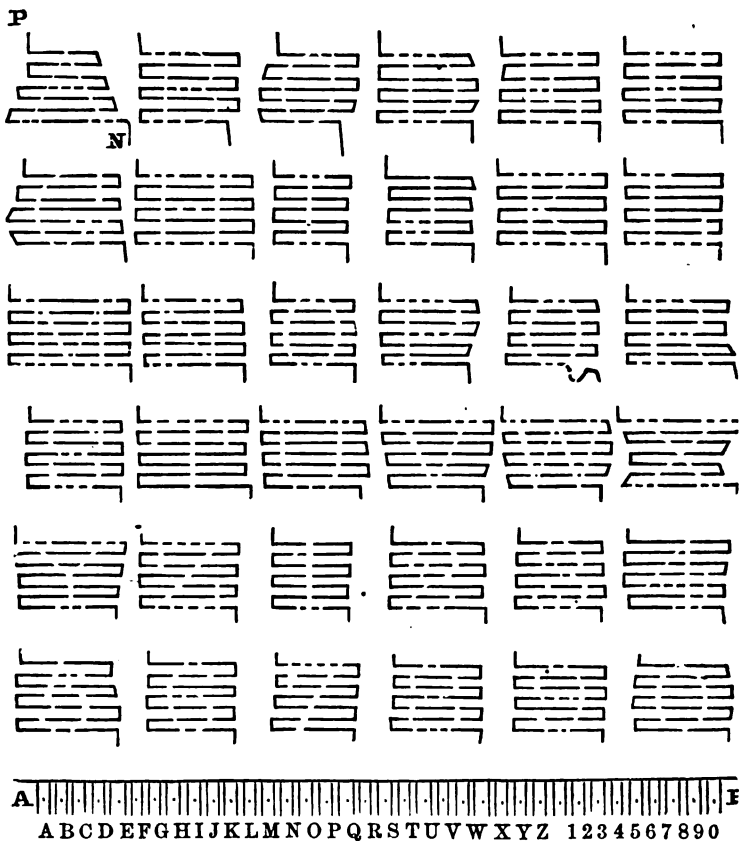

interrupted points of the tin foil, the glass upon which the conductors are pasted being an imperfect conductor. The instant the discharge is made through the wire, the spark is seen simultaneously at each of the interruptions or breaks of the tin-foil,

constituting the letter, and the whole letter is rendered visible at once." This table is placed at any one station, and the electrical machine at the other, with seventy-two wires enclosed in a glass tube connecting the two stations. He could have operated with equal efficiency by using thirty-seven wires, having one wire for a common communicating wire, or with thirty-six wires, by substituting the ground for his common wire. It does not appear that it was ever operated to any considerable extent.

DR. SALVA'S ELECTRIC SPARK TELEGRAPH.

In 1798, Dr. Salva, in Madrid, constructed a similar telegraph as that suggested by Reizen, as will be found on reference to Vorgt's Magazine, vol. xi., p. 4. The "Prince of Peace" witnessed his experiments with much satisfaction, and the Infant Don Antonio engaged with Dr. Salva in improving his instrument. It is stated that his experiments extended through many miles of wire. No description of his plans were given to the public.

BARON SCHILLING'S ELECTRIC TELEGRAPH.

The following, in relation to Schilling's telegraph, is taken from the Polytechnic Central Journal, Nos. 31, 32, 1838:

"Baron Schilling, of Cronstadt, a Russian counsellor of state, likewise occupied himself with telegraphs by electricity (see *Allgem Bauztg*, 1837, No. 52, p. 440), and had the merit of having presented a much simpler contrivance, and of removing some of the difficulties of the earlier plans. He reckoned many variations to the right or left, following in a certain order for a telegraphic sign, as, indeed, in this manner, the needle was strongly varied, and only came to rest gradually after many repeated vibrations; he introduced a small rod of platinum, with a scoop, which dipped into a vessel of quicksilver, placed beneath the needle, and, by the check given, changed the vibration of the needle into sudden jerks. In order to apprise the attendant of a telegraphic dispatch, he loosed an alarm. How much of this contrivance was Schilling's own, or whether a portion of it was not an imitation of Gauss and Weber, the author cannot decide; but that Schilling had already experimented, probably with a more imperfect apparatus, before the Emperor Alexander, and still later before the Emperor Nicholas, is affirmed by the documents quoted."

There may be a mistake in the supposition, that the telegraph of Baron Schilling had been exhibited to Alexander, as that Emperor died in 1825, and there is no evidence to show that the telegraph had been devised by Baron Schilling thus early.

From the report of the "Academy of Industry," Paris, February, 1839, I make the following extract, in relation to the same subject :

"At the end of the year 1832, and in the beginning of 1833, M. Le Baron de Schilling constructed, at St. Petersburg, an electric telegraph, which consisted in a certain number of platinum wires, insulated and united in a cord of silk, which put in action, by the aid of a species of key, thirty-six magnetic needles, each of which was placed vertically in the centre of a multiplier. M. de Schilling was the first who adapted to this kind of apparatus, an ingenious mechanism, suitable for sounding an alarm, which, when the needle turned at the beginning of the correspondence, was set in play by the fall of a little ball of lead, which the magnetic needle caused to fall. This telegraph of M. de Schilling was received with approbation by the Emperor, who desired it established on a larger scale, but the death of the inventor postponed the enterprise indefinitely."

Dr. Steinheil, in his article "upon telegraphic communication," published in the London Annals of Electricity, states, that "the experiments instituted by Schilling, by the deflection of a single needle, seems much better contrived than the arrangement Davy has proposed, in which illuminated letters are shown by the removal of screens placed in front of them."

It would appear that the French report is either incorrect, or that M. de Schilling had two plans in contemplation. His plan as intimated in the first and third extracts, is that of using a single needle in the form of a galvanometer, by means of which he made his signals; for instance, one deflection to the right might denote *e*, two *i*, three *b*; one deflection to the left *t*, two *s*, three *v*. His code of signals would then be devised in the manner shown on the following page.

If, however, his plan was that ascribed to him, by the Academy of Industry, of using thirty-six needles and seventy-two wires, it was exceedingly complicated and expensive, and was similar to that invented by Mr. Alexander, with the exception that Schilling used twice the number of wires.

During my recent residence in St Petersburg, I endeavored to obtain some further information in regard to this telegraph, but it was not possible to discover more than is embraced above

BARON SCHILLING'S CODE OF SIGNALS.

rl	A	rrrl	K	llr	U
rrr	B	lrrr	L	lll	V
rll	C	lrl	M	rlrl	W
rll	D	lr	N	lrllr	X
r	E	rlr	O	rllr	Y
rrrr	F	llrr	P	rlrr	Z
llll	G	lllr	Q	rllr	&
rlll	H	lrr	R	llrl	go on
rr	I	ll	S	lrll	stop
rlll	J	l	T	llrl	finish

rlrlr	1	lrllr	6
rllrr	2	rlllr	7
rlllr	3	rllrr	8
lrrrl	4	llrll	9
lrrll	5	llrrl	0

GAUSS AND WEBER'S ELECTRIC TELEGRAPH.

This telegraph seems, by the best authorities, to have been invented in 1833, by Counsellor Gauss and Professor Weber, at Gottingen.

The deflection of the magnetic bar, by means of the multiplier, through the agency of the galvanic fluid, excited by the magneto-electric machine, is the basis of their plan.

Fig. 2 represents a side view of the apparatus, used at the receiving station; *a a* is a side view of the multiplier, composed of 30,000 feet of wire (almost five and a half miles), upon a table *b*; *n s* is the magnetic bar, weighing thirty pounds, from which rises a vertical stem, *o*, upon which is a rod at right angles, supporting a mirror *h*, on one end, and at the other a metallic ball *i*, as a counteracting weight to that of the mirror. The magnetic bar is suspended by a small wire, fastened to the vertical stem, and at the top is wound round the spiral of the screw *i*, which turns in the standard *h'* and *h*, upon the platform *A*, and which is secured to the ceiling. In the standards *h'*, there is cut a female screw, of the same gradation as that upon which the wire is wound. By this means, the magnetic bar may be raised or let down, by turning the screw, without taking the bar from its central position in the multiplier; *g* is a screw for fastening the spiral shaft, when properly adjusted. *p* and *n* are the two ends of the wire of the multiplier. *c* is a stand for supporting the spy-glass *d*, and also the case *e*, into which slides the scale *f*. The mirror *h* is at right angles with

the magnetic bar, and presents its face to the spy-glass D, as also to the scale at E. It is so adjusted, that the reflection of the scale at E from the mirror, may be distinctly seen from the spy-glass. If the magnetic bar turns either to the right or left, the mirror must move with it, and if a person is observing it through the spy-glass, the scale will appear to move at the same time, thereby presenting to the eye of the observer another part of the scale than that seen when the bar is not deflected. The figures on the scale will show in what direction the bar has

Fig. 2.

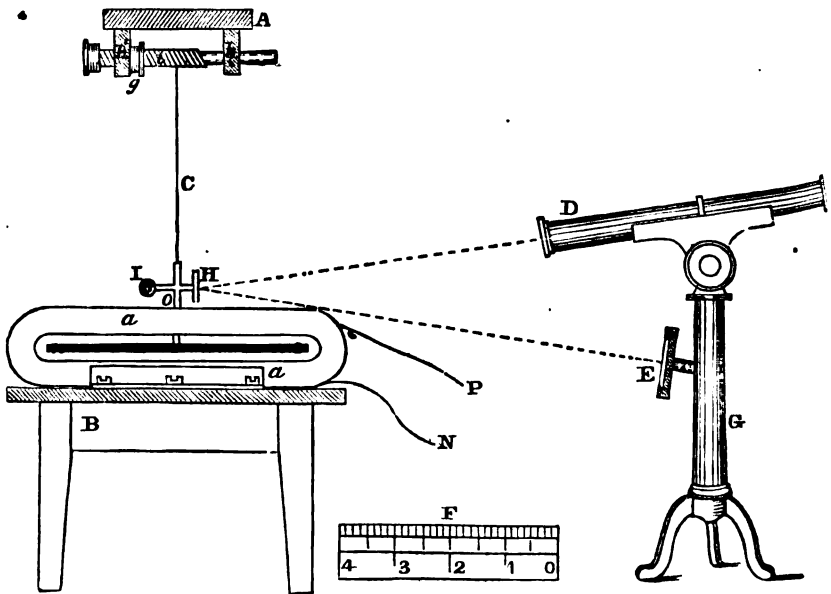

turned, and thus render it distinct to the observer, the only apparent object of the mirror, spy-glass, and scale.

For the purpose of generating the galvanic fluid, they use the magneto-electric machine. There is also required for the purpose of making the desired deflections of the magnetic bar, a communicator or pole-changer. Fig. 2 represents that portion of the apparatus at the *receiving* station. The magneto-electric machine, and the pole-changer, properly connected, are the instruments of the *transmitting* station. Two wires, or one wire and the ground, form the circuit between these two stations. The machine is put in operation by turning the crank, and the person sending the intelligence is stationed at the com-

mutator, and directs the current through the extended wires to the multiplier of the receiving station, so as to deflect the bar to the right or left, in any succession he may choose, or suspend its action for any length of time.

But in the apparatus for observation, the observer looks into the spy-glass, and writes up the kind and results of the variations of the magnetic needle. In order to have a control of the recorder, let there be a good number of spy-glasses directed toward the same mirror, in which observers may watch independently of each other. Suppose that five variations of the magnetic needle signifies a letter, L denotes a variation to the left, and R to the right. Then might R R R R denote A, R R R L denote B, R R L R C, R L R R denote D, and so on. In the whole, we obtain by the different arrangements of the five, which are made with the two letters R and L, thirty-two different telegraphic signs, which may answer for letters and numbers, and of which we can select those where the most changes are introduced between R and L, as the most common letters, in order, in the best possible manner, to notice the constant variations of the magnetic needle.

The following would be the alphabetical and numerical signs, as arranged from the above directions :

A	r r r r r	I or Y	l l r l l	R	r r r l l
B	r r r r l	K	l r r r l	S or Z	r r l r l
C	r r r l r	L	r l r r r	T	l l r l r
D	r r l r r	M	r r l l l	U	r l l l r
E	r l r l r	N	l l l l l	V	l r r l l
F	l r r r r	O	l r l l l	W	l l l l r
G or J	l r l r r	P	l r l r l		
H	r l r r l	Q	l l r r r	

1	r l l l l	:	6	r l l r r
2	r r l l r	:	7	l l l r l
3	r l r l l	:	8	l l r r l
4	r l l r l	:	9	l r r l r
5	l l l r r	:	0	l r l l r

ALEXANDER'S ELECTRIC TELEGRAPH.

A model to illustrate the nature and powers of this machine was exhibited at the Society of Arts in Edinburgh, Scotland, November, 1837. The model consists of a wooden chest, about five feet long, three feet wide, three feet deep at the one end, and one foot at the other. The width and depth in this model

are those which would probably be found suitable in a working machine ; but it will be understood that the length in the machine may be a hundred or a thousand miles, and is limited to five feet in the model, merely for convenience. Thirty copper wires extend from end to end of the chest, and are kept apart from each other. At one end (which, for distinction's sake, we shall call the south end) they are fastened to a horizontal line of wooden keys, precisely similar to those of a pianoforte ; at the other, or north end, they terminate close to thirty small apertures, equally distributed in six rows of five each, over a screen of three feet square, which forms the end of the chest. Under these apertures on the outside, are painted, in black paint, upon a white ground, the twenty-six letters of the alphabet, with the necessary points, the colon, semicolon, and full point, and an asterisk, to denote the termination of a word. The letters occupy spaces about an inch square. The wooden keys, at the other end, have also the letters of the alphabet,

Fig. 3.

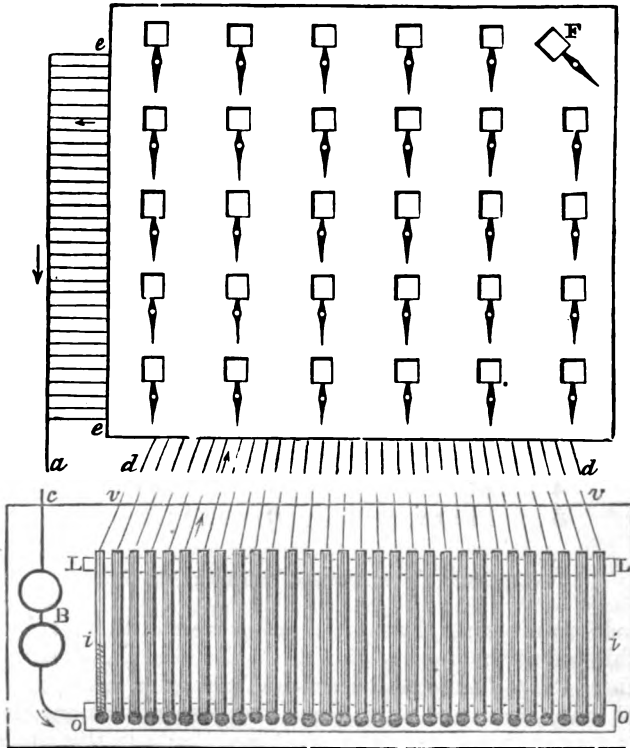

painted on them in the usual order. The wires serve merely for communication, and we shall now describe the apparatus by which they work.

This consists, at the south end, of a pair of plates, zinc and copper, forming a galvanic trough, placed under the keys; and at the north end, of thirty steel magnets, about four inches long, placed close behind the letters painted on the screen. The magnets move horizontally on axes, and are poised within a flat ring of copper wire, formed of the ends of the communicating wires. On their north ends they carry small square bits of black paper, which project in front of the screen, and serve as opercula, or covers, to conceal the letters. When any wire is put in communication with the trough at the south end, the galvanic influence is instantly transmitted to the north end; and in accordance with the well-known law, discovered by Ørsted, the magnet at the end of that wire instantly turns round to the right or left, bearing with it the operculum of black paper, and unveiling a letter. When the key, A, for instance, is pressed down with the finger at the south end, the wire attached to it is immediately put in communication with the trough; and at the same instant, letter A, at the north end is unveiled, by the magnet turning to the right, and withdrawing the operculum. When the finger is removed from the key, it springs back to its place; the communication with the trough ceases; the magnet resumes its position, and the letter is again covered. Thus by pressing down with the finger, in succession, the keys corresponding to any word or name, we have the letters forming that word, or name, exhibited at the other end; the name VICTORIA, for instance, which was the maiden effort of the telegraph, on the exhibition before the Society of Arts, above referred to.

The above description is all that I have been able to obtain in relation to this plan of an electric telegraph; and here introduce, fig. 3, to illustrate it. The thirty needles are represented on the screen, each carrying a shade, which conceals the letter when the needle is vertical. The needle belonging to the letter F, is, however, deflected, and the letter is exposed. The screen is supposed to be at the *receiving* station. To the left hand of the screen, thirty wires, *e e*, are seen joined to one, *a*; the other thirty wires, *d d*, are seen below the screen.

SOEMMERING'S ELECTRO-CHEMICAL TELEGRAPH.

CHAPTER X.

Soemmering's Electric Telegraph of 1809—The Apparatus and Manipulation Described—Signal Keys for opening and closing the Circuits.

SOEMMERING'S ELECTRIC TELEGRAPH OF 1809.

THE telegraph invented, in 1809, by Mr. Samuel Thomas Soemmering, was an electro-chemical telegraph. He was the first to use the voltaic pile as a generator of the electric current for telegraphic purposes.

Fig. 1.

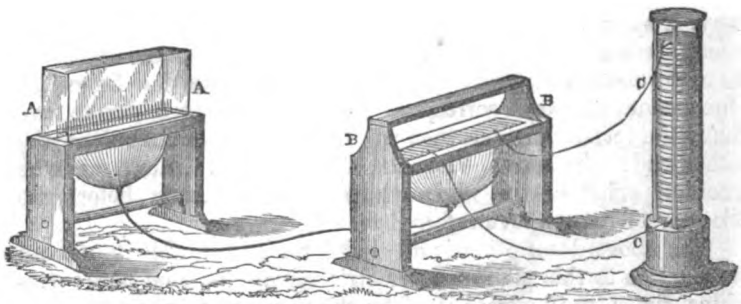

From the description, hereinafter given, it will be seen that Mr. Soemmering contemplated the use of twenty-six or more wires, or, in other words, a wire for each letter, figure, or special signal. The wires were to be insulated with silk, and arranged as seen in fig. 1, between stations A A and B B. The mechanical arrangement for putting the battery on to any given wire was very perfect, and any two of the wires could be readily connected, so as to have a return of the current to the other end of the pile, as then deemed necessary in the formation of electric currents. When the current was thus sent, the

gold points connected with the two wires at the distant station gave off bubbles of oxygen and hydrogen gases, and the two letters corresponding therewith were thus denoted.

In order to have a call, he proposed to liberate a wound-up alarm, by means of the evolution of gas, but to what extent it was found practicable no evidence is to be found.

From the experiments of Mr. Soemmering, as reported to the Academy of Science at Munich, Germany, the instantaneous appearance of the gas, when the battery was thrown into the circuit, seemed to be conclusive, and he concluded that the passage of the galvanic force was instantaneous. He also found that the addition of 2,000 feet of wire in the length of his circuit, produced little or no sensible additional resistance, and that for nearly 3,000 feet of wire, the decomposition of the water, and the appearance of the gas at the distant station, commenced simultaneously with the sending of the current.

By a careful study of the process of telegraphing devised by Soemmering, the reader will readily see that there was as much in the invention as was possible with the then known science, and even to this day there has been but little advance in electric telegraphing, without the aid of Ersted's discovery of electromagnetism, in 1819. The chemical telegraphs of Bain, Morse, and others, are but a step beyond Soemmering.

Without further remark, I will now give a description of this early invention in the language of Mr. Soemmering.

THE APPARATUS AND MANIPULATION DESCRIBED.

“The fact that the decomposition of water may be produced with certainty and instantaneously, not only at short, but at great distances from the voltaic pile, and that the decomposition may be sustained for a considerable time, suggested to me the idea, that it might be made subservient for the purposes of transmitting intelligence in a manner superior to the plan in common use, and would supersede them. My engagements are such that I have only been able to test the practicability of my plan upon a small scale, and herewith submit, for the academy's publication, an account of the experiment.

“My telegraph was constructed and used in the following manner: In the bottom of a glass reservoir, of which A A, in figs. 1 and 2, is a sectional view, are 35 golden points, or pins, passing up through the bottom of the glass reservoir, marked A, B, C, &c., 25 of which are marked with the 25 letters of the German alphabet, and the ten numerals. The 35 points are each connected with an extended copper wire, soldered to them, and extending through the tube, E, to the distant station, B B, fig.

2, are there soldered to the 35 brass plates, upon the wooden bar, κ κ Through the front end of each of the plates, there is

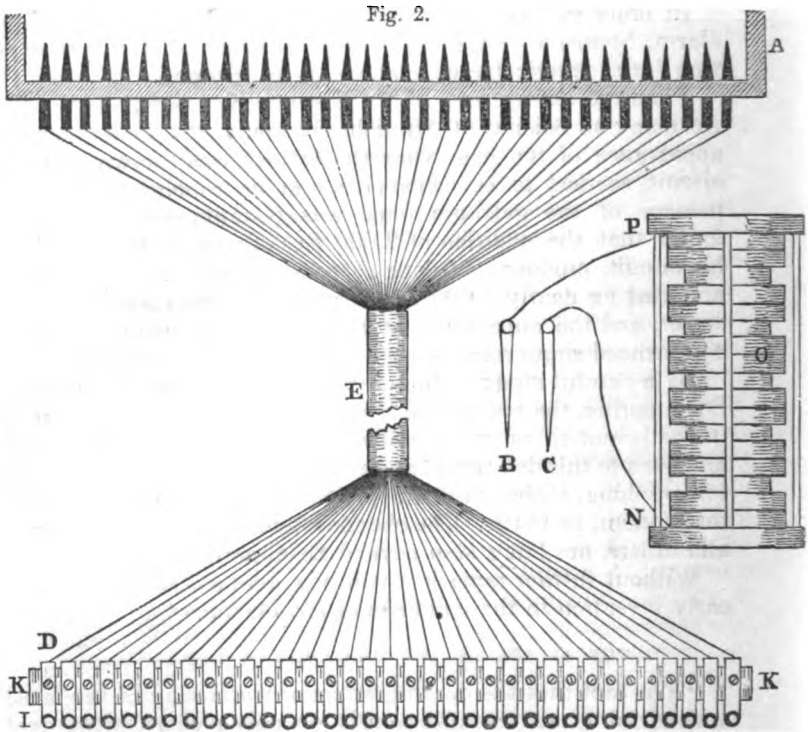

a small hole, *i*, for the reception of two brass pins, *b* and *c*; one of which is on the end of the wire connecting the positive pole, and the other the negative pole of the voltaic column, *o*, fig. 1, and as seen attached to the voltaic pile, fig. 2, by the wires *c c*. Each of the 35 plates are arranged upon a support of wood, *κ κ*, to correspond with the arrangement of the 35 points at the reservoir, and are lettered accordingly. When thus arranged, the two pins from the column are held, one in each hand, and the two plates being selected, the pins are then put into their holes and the communication is established. Gas is evolved at the two distant corresponding points in an instant: for example, *κ* and *τ*. The peg on the hydrogen pole, evolves hydrogen gas, and that on the oxygen pole, oxygen gas.

“In this way every letter and numeral may be indicated at the pleasure of the operator. Should the following rules be ob-

served, it will enable the operator to communicate as much, if not more, than can be done by the *common telegraph*.

“*First Rule.* As the hydrogen gas evolved is greater in quantity than the oxygen, therefore, those letters which the former gas represents, are more easily distinguished than those of the latter, and must be so noted. For example, in the words *ak, ad, em, ie*, we indicate the letters *a, a, e, i*, by the hydrogen; *k, d, m, e*, on the other hand, by the oxygen poles.

“*Second Rule.* To telegraph two letters of the same name, we must use a unit, unless they are separated by the syllable. For example, the name *anna*, may be telegraphed without the unit, as the syllable *an*, is first indicated and then *na*. The name *nanni*, on the contrary, cannot be telegraphed without the use of the unit, because *na* is first telegraphed, and then comes *nn*, which cannot be indicated in the same vessel. It would, however, be possible to telegraph even three or more letters at the same time by increasing the number of wires from 25 to 50, which would very much augment the cost of construction and the care of attendance.

“*Third Rule.* To indicate the conclusion of a word, the unit 1 must be used. Therefore, it is used with the last single letter of a word, being made to follow the ending letter. It must also be prefixed to the letter commencing a word, when that letter follows a word of *two letters* only. For example: *Sie lebt* must be represented *Si, e1, le, bt*, that is the unit 1, must be placed after the first *e*. *Er, lebt*, on the contrary, must be represented, *Er, 1l, eb, t1*; that is, the unit 1 is placed before the *l*. Instead of using the unit, another signal may be introduced, the cross, †, to indicate the separation of syllables.

“Suppose now the decomposing table is situated in one city, and the pin arrangement in another, connected with each other by 35 continuous wires, extended from city to city. Then the operator, with his voltaic column and pin arrangement at one station, may communicate intelligence to the observer of the gas at the decomposing table of the other station.

“The metallic plates with which the extended wires are connected have conical shaped holes in their ends; and the pins attached to the two wires of the voltaic column are likewise of a conical shape, so that when they are put in the holes, there may be a close fit, prevent oxydation, and produce a certain connection. It is well known that slight oxydation of the parts in contact will interrupt the communication. The pin arrangement might be so contrived as to use permanent keys, which for the 35 plates or rods would require 70 pins. The

first key might be for hydrogen *A*; the third key for hydrogen *B*; the fourth key for oxygen *B*, and so on.

“The preparation and management of the voltaic column is so well known, that little need be said except that it should be of that durability as to last more than a month. It should not be of very broad surfaces, as I have proved that six of my usual plates (each one consisting of a Brabant dollar, felt, and a disk of zinc, weighing 52 grains) would evolve more gas than five plates of the great battery of our Academy. As to the cost of construction, this model which I have had the honor to exhibit to the Royal Academy, cost 30 florins. One line consisting of 35 wires, laid in glass or earthen pipes, each wire insulated with silk, making each wire 22,827 Parisian feet, or a German mile, or a single wire of 788,885 feet in length, might be made for less than 2,000 florins, as appears from the cost of my short one.”

SIGNAL KEYS FOR OPENING AND CLOSING THE CIRCUITS.

Before concluding this chapter, I will add a few explanations in regard to the figures 1 and 2 relatively. Fig. 1 is a perspective view, embracing the two offices. *A A* is one station and *B B* the other, *c c* is the voltaic pile at *B B*. The wires from *A* to *B* are united into a cord and lashed together, but each wire insulated one from the other.

Fig 2 is a different view of the sending station *B* and of the receiving station, *A*. *o* is the voltaic pile as seen in fig, 1, represented by *c c*. The signal keys, *B c*, fig. 2, close the circuit by being placed in the holes, *i*, of the frame, *κ κ*. To each of these metallic holes is connected one of the line wires. The metallic points at the other station, *A*, each of which represents a given letter or figure, the same as at the station, *κ κ*. The signal keys may be applied in the form mentioned, but they may be connected with a key-board like a piano, as Soemmering indicated, so that the pressure upon any key will form the metallic contact, and transmit the electric current on the wire representing the letter touched, as practically operated in the telegraphs of the present day. The forms given in the figures are thus presented, to enable the reader to understand the organization of the ingenious arrangement devised by Soemmering for telegraphic purposes. Amidst the many inventors of the different contrivances of telegraph apparatuses, the name of Soemmering is entitled to stand in bold and golden letters, for certainly, his combination was a rapid stride toward the consummation of a practical electric telegraph, the most transcendent star in the inventive galaxy of the present century.

RONALD'S ELECTRIC TELEGRAPH.

CHAPTER XI.

Invention of Ronald's Electric Telegraph—Experiments and Description of the Apparatus—Description of an Electrograph.

INVENTION OF RONALD'S ELECTRIC TELEGRAPH.

THE Ronald Electric Telegraph was invented in 1816, at Hammersmith, London, England, by Mr. Francis Ronald, and a description of it was published by him in 1823. He erected eight miles of insulated wire on his lawn, and besides, he buried in the earth five hundred and twenty-five feet, in a trench dug for that purpose, four feet deep. The wire through the air was insulated with silk strings suspended from trees and poles. The subterranean wire was placed through thick glass tubes, and these were placed in troughs made of dry wood, two inches square. The troughs were filled with pitch. He employed the ordinary electric machine, generating high-tension electricity, and the pith-ball electrometer, in the following manner. He placed two clocks at two stations; these clocks had upon the second-hand arbor a dial with twenty letters on it; a screen was placed in front of each of these dials, and an orifice was cut in each screen, so that one letter only at a time could be seen on the revolving dial. These clocks were made to go isochronously, and, as the dial moved round, the same letter always appeared through the orifices of each of these screens. The pith-ball electrometers were hung in front of the dials.

It is evident, therefore, that, if these pith-balls could be made to move at the same instant of time, a person at the transmitting station, by causing such motion in both those electrometers, would be able to inform the attendant at the distant

or receiving station what letters to note down as they appeared before him in succession on the dial of the clock.

Fig. 1

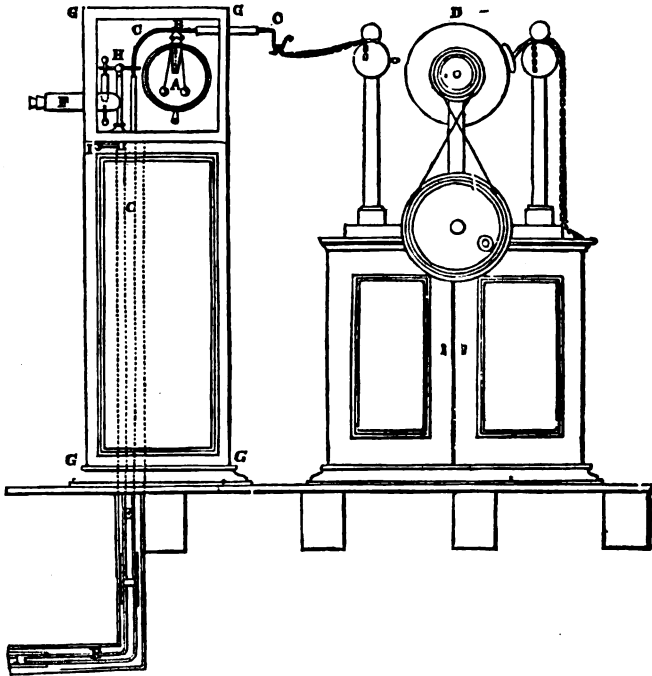

This was accomplished in the following manner: The transmitter caused a current of electricity to be constantly operating upon the electrometers, so as to separate the balls of those electrometers, except only when it was required to denote a letter, and then he discharged the electricity from the wire, and instantly both balls collapsed. The distant observer was thereby informed to note down the letter then visible. In this way letter after letter could be denoted, words spelled, and intelligence of any kind transmitted. All that was absolutely required for this form of telegraph was, that the clocks should go isochronously *during the time* that the intelligence was being transmitted; for it was easy enough, by a preconcerted arrangement between the parties, and upon a given signal, for each party to start their clocks at the same letter, and thus, if the clocks went together during the transmission of the intelligence, the proper letters would appear simultaneously, until the commu-

nication was finished. The attention of the distant observer was called by the explosion of gas by means of electricity from a Leyden jar.

Fig. 2.

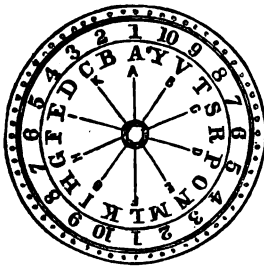
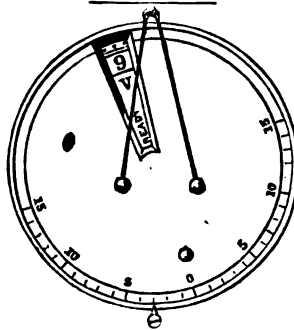

Fig. 3.



EXPERIMENTS AND DESCRIPTION OF THE APPARATUS.

Mr. Ronald has given the following additional explanations of his invention in his work, entitled a "Description of an Electric Telegraph, and some other Electrical Apparatus:"

In fig. 1, *D* is an electrical machine; *B*, the pith-ball electrometer; *A*, the screen hiding the letters on the dial behind it; *F*, the gas alarm; *E*, the tube conveying the wires.

Fig. 2 shows the moveable dial hidden by the screen in fig. 1.

Fig. 3 is an enlarged drawing of the screen, with orifice and pith-ball electrometer.

Mr. Ronald entered on the subject of the comparative merits of wires suspended in the air and wires buried in the earth, and arrived at the conclusion that subterranean wires were much to be preferred, although many persons were found to object to that plan.

He says: "The liability of the subterranean part of the apparatus to be injured by an enemy or by mischievously disposed persons has been vehemently objected to—more vehemently than rationally, I presume to hope (as is not unfrequently the case on these as on many other sorts of occasions). If an enemy had occupation of all the roads which covered the wires, he could undoubtedly disconcert my electric signs without difficulty; but would those now in use escape? And this case relates only to invasions and civil war; therefore let us have smokers enough to prevent invasions, and kings that love their subjects enough to prevent civil wars.

"To protect the apparatus from mischievously disposed per-

sons, let the tubes be buried six feet below the surface of the middle of the high roads, and let each tube take a different route to arrive at the same place. Could any number of rogues then open trenches six feet deep, in two or more different public high roads or streets, and get through two or more strong cast-iron troughs, in less space of time than forty minutes? for we shall presently see that they would be detected before the expiration of that time. *If they could*, render their difficulties greater by cutting the trench deeper, and should they still succeed in breaking the communication by these means, hang them if you catch them, damn them if you cannot, and mend it immediately in both cases."

In further explanation Mr. Roland states, that the circular brass plate, fig. 2, was divided into 20 equal parts, and it was fixed upon the seconds' arbor of a clock which beat dead seconds. Each division was marked by a figure, a letter and a preparatory sign. The figures were divided into two series, from 1 to 10, the letters were arranged alphabetically, leaving out j, q, u, w, x, z. The preparatory signs are indicated by the position of the rays indicated by A, B, C, D, E, F, G, H, I, K, and represent as follows, viz., A, prepare; B, ready; C, repeat sentence; D, repeat word; E, finish; F, annul sentence; G, annul word; H, note figures; I, note letters; K, dictionary.

Before and over the disk, fig. 2, was fixed a brass plate, fig. 3, capable of being occasionally moved by the hand round its centre, and which had an aperture of such dimensions, that while the disk was carried round by the motion of the clock, only one of the letters, figures, and preparatory signs upon it could be seen through the aperture at the same time; for instance, the figure 9, the letter v, and the sign "Ready," are now visible through the aperture in fig. 3. In front of this pair of plates, A, fig. 1 and 4, was suspended an electrometer of Canton's pith balls, from a wire E, which was insulated, and communicated with a cylindric electrical machine of only 6 inches in diameter, and with the wire C 525 feet long, which was insulated in glass tubes, surrounded by the wooden trough filled with pitch, and buried in a trench cut 4 feet deep in the ground.

Another similar electrometer was suspended in the same manner before another clock, similarly furnished with the same kind of plates and electrical machine. This second clock and machine were situated at the other end of the buried wire, and it was adjusted to go as nearly as possible synchronously with the first. Hence, it is evident, that when the wire was charged by the machine at either end, the electrometers at both ends

diverged; when it was discharged suddenly at either station, they both collapsed at the same instant; and when it was discharged at the moment that a given letter, figure, and sign, on the lower plate of one clock appeared in view through the aperture, the same figure, letter, and sign appeared also in view at the other clock; and that, by such discharges of the wire at one station, and by noting down the letters, figures, or signs in *view*, at the other, any required words could be spelled, and

Fig. 4.

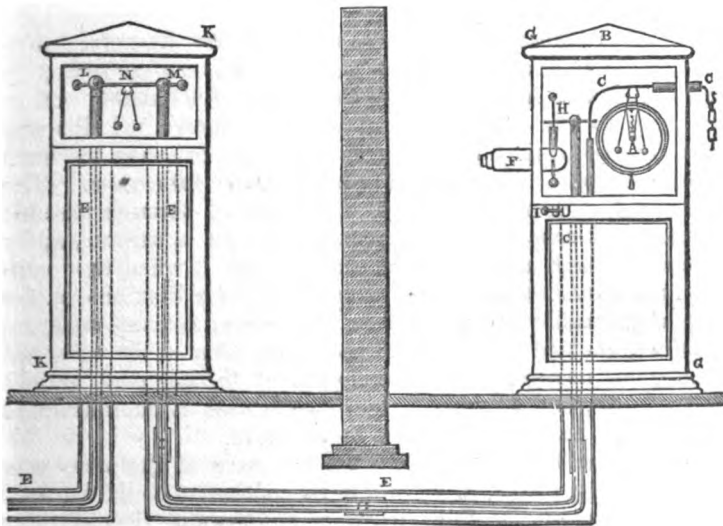

figures transmitted. But by the use of a telegraphic dictionary, a word, or even a whole sentence, could be conveyed by only 3 discharges, which could be effected in the shortest time in 9 seconds, and in the longest, in 90 seconds, making a mean of 54 seconds. This dictionary consisted of 10 leaves cut in the manner of a common-place book, or ledger; each leaf was also divided into 10 columns, and each column numbered on the top of the page. The columns were intersected by 10 horizontal lines, each numbered on the left side. The space produced by the intersections was occupied by words or sentences.

It was necessary to distinguish the preparatory signs from those intended to spell or refer to the dictionary, by giving the wire a rather higher charge than usual, and thus causing the

pith balls to diverge more ; and it was always understood that the first sign, viz., "*Prepare*," was made when that word, the letter *A*, and figure 1, were in view at the communicator's clock ; so that should the communicant's clock not exhibit the same sign (in consequence of its having gained or lost more than the communicator's), he noted how many seconds it had lost or gained, and moved his upper plate on its centre through just so many seconds to the right or left as occasion required, and the communicator continually repeated his sign "*Prepare*," until the communicant had adjusted his clock, and had discharged the wire at the moment when the word "*Ready*," appeared in view.

A second preparatory sign was now made by the communicator, provided that the word or sentence was not contained in the dictionary, or that the figures were to be noted, not as referring to the dictionary, but in composition ; and this was done by discharging the wire at the moment when the term "*Note Letters*," or "*Note Figures*," came into view. The gas pistol, *F*, in figs. 1 and 4, which passed through the side of the clock-case, *G*, was furnished with an apparatus, *H*, by means of which a spark might pass through it when the communicator made the sign "*Prepare*," in order that the explosion might excite the attention of the communicant, and the handle *I*, enabled him to break the connection of it with the wire when necessary. The explosion of the gas pistol served as an alarm, but to what extent it was used to communicate by sound, I have not been able to ascertain.

At half the distance between the two ends of the wire was placed the apparatus, *K*, by which its continuity could be broken at pleasure, for the purpose of ascertaining (in case any accident had happened to injure the insulation of the buried wire) which half had sustained the injury, or if both had. It is seen that the two portions of the wire and tube rose out of the earth, and terminated in two clasps, or forks, *L* and *M*, and the wire, *N*, carrying a pair of pith balls resting on these forks, connected them. Now, by detaching this connecting wire from the fork *L*, while it still remained in contact with the fork *M*, or *vice versa*, it could be seen which portion of the wire did not allow the balls of the electrometer to diverge, and consequently which had lost its insulation, or if both had. Mr. Ronald submitted his telegraph to the Admiralty, for adoption by the government, but he was informed that "*telegraphs of any kind were then wholly unnecessary*," and that "*no other than the one then in use would be adopted*." There the matter ended.

DESCRIPTION OF RONALD'S ELECTROGRAPH.

Besides the efforts of Mr. Ronald to establish his electric telegraph in 1816, and in subsequent years, he invented an apparatus called an "electrograph." This instrument has been construed to be a step in the march of telegraphic invention, and in substantiation of which, it was placed in the pleadings of a contesting party in one of his telegraph suits in America.

Fig. 5 represents the new electrograph, a description of which was published by Mr. Ronald in London, in 1823. He said :

Whoever has been possessed of a sufficient share of curiosity and patience to examine the extraordinary and amusing series of phenomena which atmospheric electricity exhibits, as observed by Signior Beccaria's exploring wire, or Mr. Bennett's, Mr. Cavallo's, and Mr. Read's apparatus, &c., must have regretted the impossibility of noting down sometimes the very *rapid* changes in *tension*, as well as in *kind* of electricity, which occur in a thunder-storm, or hard shower of rain, hail, snow, &c., in such manner as to convey *a correct idea* of the different very short intervals of time in which they occur, as well as of the extraordinary phenomena themselves. Hence, *perhaps*, arose the idea of employing an electrograph, a far more *necessary* instrument than the barometrograph, &c., &c. The phenomena displayed by the electricity of serene weather, and of dew, are not, however, less interesting, or less deserving attention, and they equally require an instrument to note them, but for the opposite reason, viz., their tediousness. Fig. 5 is an electrograph, which may be applied to either purpose.

A A is a box, containing a strong timepiece, placed in a horizontal position, and receiving motion from the weight B. ; C is a circular plate of baked mahogany wood, eight inches in diameter, having a perforation, D, of two inches and a half diameter. The circumference of this plate, and that also of the perforation, are provided with edges, or rims, and the outer broad rim is divided off, and marked with hours and minutes, in the manner of a common clock. The space between the two edges is nearly filled with cement, composed of resin, bees' wax, and lamp-black, and this part of the apparatus can be detached at will from the box. E F is a glass tube, furnished with brass caps (and covered both inside and out with hard cement), the lower end of which screws upon the dial-plate of the timepiece, and the upper end carries a small cylinder or sheave, G. *Within this tube*, E F, a stem of glass is fixed by its lower end on the

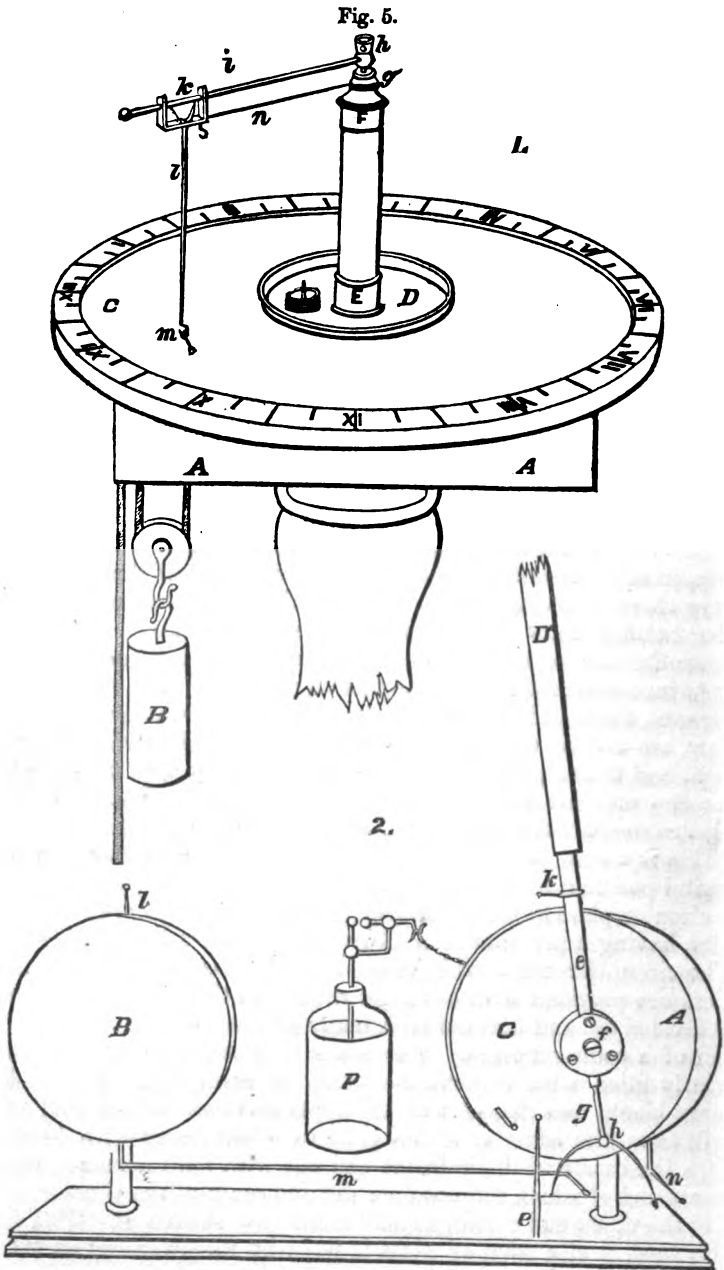

minute arbor of the timepiece, and a pivot, attached to its upper end, passes through the cap F and the cylinder g . This pivot carries the iron ball and cup, h , into which is screwed a steel wire, i , and this carries the piece, k , which may slide with a little friction upon it. The wire l , fixed into the piece k , terminates at its lower end in a hook, and another short wire, m , is furnished with a ring at one end, by which it is attached to the hook, and with a small gold bead at the other, which rests upon the resinous plate. Lastly, a fine thread, n , is also attached by one end to the piece k , and by the other to the cylinder g .

When the clock is in motion, and the apparatus disposed as is represented in the figure, it carries round the arm k , and of course carries the thread n , to coil itself round the stationary cylinder, g , the piece k to advance toward the ball h , and the gold bead, which *trails* upon the resinous plate, to describe a spiral thereon.

And when a communication is established between the little iron cup above h (which contains a globule of mercury, in order to secure perfect contact) and a wire connected with any species of atmospheric apparatus, the gold bead acts upon the resinous plate like Mr. Bennett's electric pen, *i. e.*, it electrifies it in such a manner, that when the plate is removed from the clock, and powdered with pounded resin, or even common *dry* hair powder, the line of the spiral exhibits configurations, which vary in form and in breadth according to the kind and intensity of electricity which the bead has communicated to it; and, by reference to the divisions on the circumference of the resinous plate, it is easy to discover the exact periods at which these occurrences took place. In short, a *comparative picture* of all the phenomena of atmospheric electricity, during the absence of the observer, is thus procured.

If the instrument be used for noting the phenomena of serene weather, dew, &c., the hour arbor is generally preferable; if for those of a thunder-storm, hard shower of rain, or hail, or snow, the minute arbor; but I have sometimes found, that a more rapid motion is required than either, which may, of course, be obtained by the addition of a third arbor, &c.; and the glass tube, $E F$, with all its appurtenances, can accordingly be easily transferred from any one arbor to another, and the plate adjusted to a new centre. It is also necessary sometimes to employ a cylinder, either larger or smaller than g . In the first case, when the more violent and more transient phenomena are to be noted; and, in the second, when a delineation of a longer period is required to be executed by the instrument;

for it is evident that, in proportion to the diameter of the cylinder *g*, will be the proportions of the volute upon the resinous plate; and that the comparatively short duration of a storm, or shower, &c., which draws a larger figure, must require a space of greater breadth, as well as length, than the other, in order to avoid confusion; the cylinder *g* can therefore be removed, and others substituted in its place.

One advantage, which I have derived from this contrivance over a cylindric electrograph, is, the power of conveniently bringing the resin into a fit state to receive the electrical drawing, the only *certain* method of doing which is to pass a heated plate of iron over it, at two or three inches distance, in order to melt it *partially* (so perfectly does it retain the figure, and so difficult is it to destroy that figure without communicating a new one by the ordinary methods); which process of heating it is almost impossible to perform upon any other surface than a plane, so as to preserve a fine even surface.

But the principal advantage over both the cylindric and plane electrograph, *proposed* by Magellan, is that derived from a comparative and comprehensive view of the daily periodical returns of the phenomena: those, for instance, of the morning and evening electricity, which Beccaria found to bear a striking relation with the periods of sunrise and sunset, and which he accounted for by the sun's action upon the vapors which were exhaled from the earth. Magellan's plate electrograph would be very cumbersome and inconvenient for such observations.

Would not the above be also a proper instrument for observations on that most extraordinary tendency which thunder-storms have to reappear, many days successively, about the same hour; and, what is more, at the precise spot where they had appeared at first. "It is necessary to inhabit," says Sig. Volta, the learned and sagacious discoverer of this new phenomenon, "a mountainous country, and particularly the neighborhood of lakes, such as Como, the precincts of Lario, Verbano, Verese, Lugano, Lecco, and the whole mountain of Brianza, Bergamo, &c., in order to be convinced of such periods and fixations (so to speak) of thunder-storms at this or that valley, or opening of a mountain, which last until some wind, or remarkable change in the atmosphere, shall occur to destroy them." Sig. Volta refers the cause of the phenomenon to a modification in the ambient air, produced by the thunder-storm of the preceding day.

STEINHEIL'S ELECTRIC TELEGRAPH

CHAPTER XII.

Experiments and Discovery of the Earth Circuit—The Electric Telegraph as Invented—The Electric Conducting Wires—Conductibility of the Earth Circuit—Apparatus for Generating the Voltaic Current—The Indicating Apparatus—Construction of the Apparatus—Application of the Apparatus to Telegraphing—The Alphabet and Numerals—The Discovery and Invention of Steinheil.

EXPERIMENTS AND DISCOVERY OF THE EARTH CIRCUIT.

IN the years 1836-'37, Prof. C. A. Steinheil, of Munich, Germany, devised an electric telegraph; and in the latter year, he constructed a line of wire from the Academy at Munich to the observatory at Bogenhausen. He had constructed two other lines, making three circuits of wires, but the whole were arranged to be united into one common chain, to form an electric circuit. The first published notice made of this important invention will be found in the third volume of the Magazine of Popular Sciences, in a letter from Munich, under date of December 23, 1836. This telegraph was announced in the *Comptes Rendu*, in September, 1838.

In 1838, Prof. Steinheil made the important discovery of the practicability of using the earth as one half or the returning section of an electric circuit. The three lines, constructed as hereinafter described, had double wires, so as to form a complete metallic circuit from and to Munich. Subsequent to the erection of these experimental lines, the earth was discovered to be a conducting medium in the formation of an electric circuit, in conjunction with the wire stretched upon poles. This was the grandest discovery ever made in practical telegraphy. The discoveries of Volta, Ørsted, and Steinheil, are to be considered as pre-eminent, in the consummation of the electric telegraph. The first discovered the generating power,

the second gave life and strength to that power, when it had become so feeble, that it seemed as though it was struggling in the arms of death; and the latter economized the commercial application of those elements for the uses of man. All telegraphs are formed upon these three discoveries. Let, then, the names of Volta, Ørsted, and Steinheil, be inscribed in golden capitals upon the bright escutcheon of telegraphic achievements, as the equals in renown, and subservers of man's weal, and the glory of the age.

Dr. Steinheil made an experiment in 1838, on the railroad. He insulated the chairs sustaining the rails with tarred felt; but this was a very imperfect insulation, and the circuit could not be extended beyond some five hundred feet. To test the matter more thoroughly, he had some new rails made, but the points of contact with other but inferior conductors were so numerous, that the experiment was for the time abandoned. This experiment produced an effect which convinced Steinheil that it was not necessary to bring a metallic conductor back to the voltaic source. The non-insulation of the rails gave off the electric current, and this fact was observed in the movement of the electrometer. Thus, when the current was transmitted over the rails, a speedy return was seen, even when the two lines of rails were not connected. Suppose the wires of the apparatus were connected to the rails on each side of the road, the rails insulated by resting upon the tarred felt, at a distance of 500 feet from the apparatus, the rails to be connected by a copper wire. The route of the current would be over the rails on one side of the road to the copper wire, and through it to the rails on the other side of the road, and thence back by the rails to the indicator. When the copper wire was disconnected, the circuit was supposed to have been broken; but it was not the case, as the current escaped from the rails, and returned with unmistakable indications at the apparatus.

Prof. Steinheil extended his discoveries still farther, and reduced them to mathematical precision as to cause and effect. He pursued this important question to its fullest extent, and gave to the world the results attained by his patient and laborious researches.

I will now proceed to explain to the reader the telegraphic apparatus invented by Prof. Steinheil, and in doing which, to a considerable extent, will use the language of the inventor. I have taken great pains to obtain the most reliable information concerning his labors in the invention of his telegraph, and his discoveries in the sciences pertaining thereto, and I hope the facts herewith presented will be found strictly correct.

THE ELECTRIC TELEGRAPH AS INVENTED.

This telegraph is composed of three principal parts :

- 1st. A metallic conductor between the stations ;
- 2d. The apparatus for generating the voltaic current ; and
- 3d. The indicator or receiving apparatus.

“ In explanation of the organization of this telegraph,” says Prof. Steinheil, “ I will explain the above divisions ; and first—

THE ELECTRIC CONDUCTING WIRES.

“ The wire which connects two or more stations, forming a part of a voltaic circuit, is called the connecting wire, and may be extended to a very great length. This wire, however, must be considered relatively to the voltaic battery. With equal thickness of the same metal, the resistance offered to the passage of the electric current, will be proportional to the thickness of the wire. With equal lengths of the same metal, however, the resistance diminishes in an inverse proportion to the sectional surface. The conductivity of metals differs. According to Fechner's measurements, copper, for example, conducts six times better than iron, four times better than brass. The conductivity of lead is still more inferior, so that the only metal most suitable, and that can best subserve the purposes in this technical application, are copper and iron wires. Iron wire is six times less in cost than copper wire, nevertheless, it is necessary that the iron conductor should be six times greater than the gauge of the copper wire, in order to equalize the conducting powers of the respective metals. The expense of the two wires is the same. The iron, however, is the strongest and heaviest. The preference will be given to copper wire, as this metal is less liable to oxydation from exposure to the atmosphere. This latter difficulty may be surmounted by simple means, namely, by galvanizing it. It is believed that the mere transmission of the voltaic current through the wire, when the telegraph is in operation, will be sufficient to preserve the iron wire from rust, as has been observed to be the case with the iron wire used for the telegraph line in the city of Munich, for more than a year past, and which, too, has been exposed to all weathers.

“ If the voltaic current is to traverse the entire metallic circuit of the wire, from station to station, without any diminution as to its intensity or force, the wire must in its whole course not be allowed to come into contact with any foreign conductors, but, on the contrary, should be perfectly insulated at every place of contact. If the wire be permitted to touch semi-conductors the electric power or current will return to the generating source by the most direct and shortest route. According

to this philosophy the extreme station from the voltaic source will be deprived of the influence of the greater part of the electric current generated by the battery.

“Numerous trials to insulate wires, and to conduct them below the surface of the ground, have led me to the conviction that such attempts can never answer successfully at great distances, inasmuch as the most perfect insulators are at best but bad or inferior conductors. And since, in a wire of very great length, the surface in contact with the so-called insulator is uncommonly large, when compared with a section of the metallic conductor, there will necessarily arise a gradual diminution of the voltaic force, inasmuch as the wires *to* and *from* the station do communicate at intermediate points. This cross current may be very small; nevertheless it will occur. It would be wrong to suppose that this difficulty can be remedied by placing the *to* and *from* wires very far apart; the distance between them is, as we shall see in the sequel, almost a matter of indifference. As it is not probable that lines laid under the ground can ever be insulated sufficiently for telegraphic purposes, because the earth is always damp, and therefore a conductor, there is but one other course open to us, and that is to lead the wire through the air. Upon this plan, it is true the conducting wire must be supported at given places; it will be liable to be injured by evil-disposed persons; it will be liable to be interrupted by storms, and from ice which will form upon it from time to time. These are the difficulties to be expected, in stretching the wire through the air, and as there is no other method that can be made available, we must endeavor to make suitable arrangements to get the better of them, although they are of no ordinary consideration.”

The conducting chain or medium of the telegraph constructed in Munich consisted of three parts :

1st. The line from the Royal Academy in Munich to the Royal Observatory at Bogenhausen;

2d. From the Royal Academy to the residence of Prof. Steinheil; and

3d. From the Royal Academy to the mechanical department attached to the cabinet of natural philosophy.

“As to the first,” says Prof. Steinheil, “the wire was run from Munich to Bogenhausen and back, making a total length of wire 32,500 feet. The weight of the copper wire employed amounted to 260 pounds. Both of the wires, that is, *to* and *from*, are stretched across the steeples of the city at distances from three to ten feet apart. The greatest distance from one support to another was 1,200 feet; this distance is un-

doubtedly far too great for a single wire, inasmuch as during winter the ice will form upon the wire, and materially increase its weight, and augment its diameter, so that it becomes liable to be torn asunder and broken by the weight or by the storms. Over those places where there are now high buildings, the conducting wire is supported by tall poles, sunk into the ground five feet, and are from forty to fifty feet high. At the top of these poles, the wires are fastened to a cross bar. At the point where the metallic conductor rests, there is a piece of felt laid, and over which the wire is twisted around the wooden bar. The distances from pole to pole range between 600 and 800 feet; but these distances are far too great, for experience has shown that the wires become stretched, caused by high winds, and they have had to be re-stretched on the poles several times. These evils may be overcome by making the conductor of three strands of wire, twisting them so as to make a cord, which will be better than a single wire. It should be supported by poles about 300 feet apart, giving the wire a tension not exceeding one third of what it will bear, without giving way. This, however, can not be made on the experimental telegraph of this city for reasons that can not be explained here.

“The conducting wire thus mounted is by no means perfectly insulated. When, for example, the circuit is broken at Bogenhausen, the electric generator at Munich ought not to produce any current upon the remainder of the wire, not connected as a circuit. But even when the circuit was thus broken at Bogenhausen, an electrometer, as devised by Gauss, being connected with the wire, a current manifested itself by the action upon the electrometer. Measurement goes to show further, that the current goes on increasing as the point, at which the interruption of the stream is made, recedes from the inductor. The amount of this current is not always the same. Generally it is greater in damp weather. When there are heavy showers of rain, it may be fairly said to be five times as strong as when the weather is dry. At small distances of a few miles, the loss of electric power is of but little importance, as by the peculiar construction of the inductor, we can generate an electric force of any strength desired. When the distance amounts to, perhaps, some 280 miles, the continual loss of the electric current will, beyond doubt, be so great, that there can be no effect produced at the distance mentioned. In such cases, much greater precaution must be taken in regard to the insulation at the points of support.

“When thunderstorms occur, atmospheric electricity collects on the semi-insulated conductors, in the same way that it does

upon lightning-rods. But this does not prevent the flow of the voltaic current.

“Reference may be made here to an incident, that may be well to remember, as a warning for the future. During a severe thunder-storm, on the 7th of July, 1838, a very strong electric spark darted at the same instant through the entire conducting wire, and on entering the apparatus in my room, a sound like the cracking of a whip was produced. At the same time the deep-sounding bell of the manipulator was made to sound. So violent was the presence of the lightning in the deviation of the needle, the revolving points of the magnetic bar were damaged. The same phenomenon was also observed at one of the other stations. As the deflecting power of frictional electricity is very inconsiderable, with respect to magnets, the above occurrence indicates the presence of a vast quantity of electricity. This phenomenon could only have arisen from the electricity of the earth having at that moment made its way to that collected in the wire. Whether this was brought about through the lightning conductors in the neighborhood, or the imperfect insulation of the points of support, cannot be well determined.”

CONDUCTIBILITY OF THE EARTH CIRCUIT.

“Quite recently I have made the discovery, that the ground may be employed as one half of the conducting chain, forming the circuit with the line wire. As in the case of frictional electricity, water or the ground may, with the voltaic current, form a portion of the connecting wire. Owing to the low conducting power of these bodies, compared with metals, it is necessary that at the two places where the metal conductor is in connection with the semi-conductor, the former should present very large surfaces of contact. Taking water, for example, which conducts two million times worse than copper, a surface of water proportional to this must be brought in contact with the copper, to enable the voltaic current to meet with equal resistance, in equal distances of water and of metal; thus, if the section of a copper wire is 0.5 of a square line, it will require a copper plate of sixty-one square feet surface, in order to conduct the voltaic current through the grounds, as the wire in question would conduct it. But as the thickness of the metal is quite immaterial in this case, it will always be within our reach to get the requisite surfaces of contact at no great expense. Not only do we by this means save half the conducting wire, but we can even reduce the resistance of the ground below what

that of the wire would be, as has been fully established by experiments made here with the experimental telegraph.

“The second portion of the conducting chain leads from the Royal Academy to my house and observatory in Lark-street. This conductor is of iron wire, and both the to and from wires are 6,000 feet long, and are stretched over steeples and other high buildings, as has already been described.

“The third portion of the chain or conducting wires runs through the interior of the buildings, connected with the Royal Academy, and thence to the mechanical workshop attached to the cabinet of natural philosophy. This is a fine copper wire, and 1,000 feet long. It is let in the joinings of the floor, and in part imbedded in the walls.

“The foregoing three different ranges or lines of wire, the first of copper, the second of iron, and the third of fine copper, in the aggregate near seven and a half miles of wire, run from and return to the same place, and to which, in whole or singly, may be attached the apparatus for generating the electric current, and for indicating the communication transmitted.”

APPARATUS FOR GENERATING THE VOLTAIC CURRENT.

Hydro-electricity, or that current which is generated by the voltaic pile, is by no means fitted for traversing *very long* conducting wires, because the resistance in the voltaic pile, even when many hundred pairs of plates are employed, would be always inconsiderable, compared with the resistance offered by the wire itself.

The principal disadvantage, however, attendant on the use of the pile or trough apparatus, is the fluctuation of the current, joined to the circumstance of its becoming very soon quite powerless, and requiring to be taken to pieces and put together again. The extremely ingenious arrangement of Morse is likewise subject to this inconvenience. All this, however, is got over, when one, to generate the current, has recourse to Faraday's important discovery of induction, that is to say, by moving magnets placed in the neighborhood or close to the conducting wires. The better way, however, is not to move the magnets, as Pixii does, in his electro-magnetic apparatus, but rather to give motion to the multipliers placed close to a fixed magnet. The arrangement that Clarke has given to the multiplier, is the one which, with some modifications, has been adopted. Assuming, on the part of the reader, a general knowledge of the principles of the apparatus, these explanations

will be confined to its adaptation to the purposes of telegraphic communication.

Fig. 1.

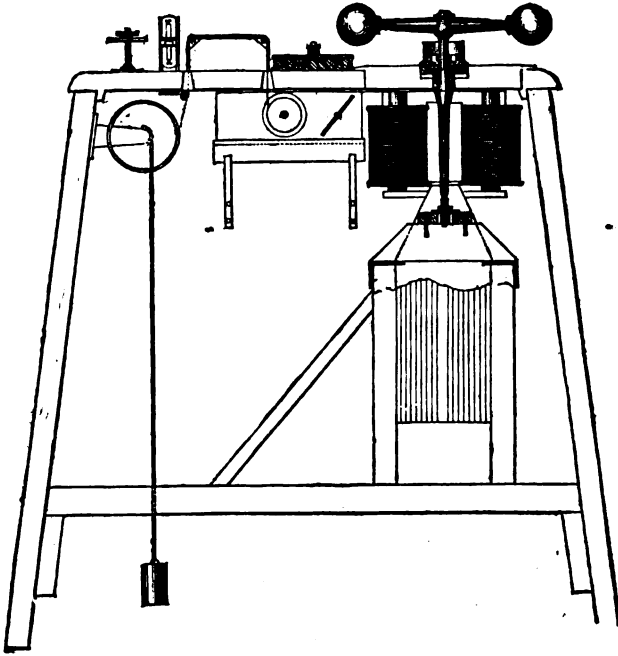

The magnet is composed of seventeen horseshoe bars of hardened steel. With its iron armature, its weight is about sixty pounds, and it is capable of supporting about 300 pounds. Between the arms of the magnet there is fastened a piece of

Fig. 2.

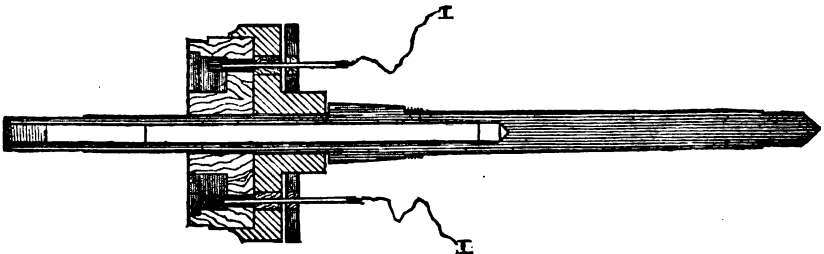

metal, supporting in its centre a cup, provided with adjusting screws, and which serves as a support for the axis of the coils

of the multiplier. The coils of the multiplier have, in all, 15,000 turns of wire; forty inches of this wire weighs fifteen and a half grains, and it is twice bespun with silk. Its two ends, which are insulated, are passed up through the interior of the vertical axis of the multiplier, and then terminate in two hook-shaped pieces, as may be seen by figs. 2 and 3. In order to insure perfect insulation, the vertical axis, fig. 2, was bored out hollow. In this hole, there are let in from above two semi-circular rods of copper, which are prevented from touching by a strip of taffeta fastened between them with glue; and these again are kept from touching the metallic axis by winding taffeta round them. In each of these little strips of metal there is, above and below, a female screw cut. In the lower holes, small metal pins are screwed in, to which the ends of the multiplier are securely soldered. While in the upper holes, as may be seen distinctly in figs. 3 and 4, there are iron hooks screwed in. These hooks, therefore, form the terminations of the multiplier wires of the coils of the inductor. They here turn down, fig. 5, into two semi-circular cups of quicksilver, that are separated by a wooden partition. From these cups of quicksilver there proceed connections, 1 1, figs. 2 and 6, toward the wires, and they, therefore, may be considered as forming part of the conducting wires or chain. The quicksilver, owing to its capillarity, stands at a higher level in these semi-circular cups than are the partitions, so that the terminal hooks of the wires of the multiplier pass over these partitions without touching them, when the multiplier is made to turn on its axis. One sees that the hooks are thus brought in to other cups of quicksilver, at every half turn of the multi-

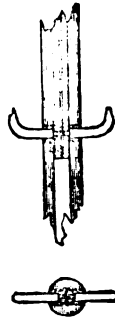
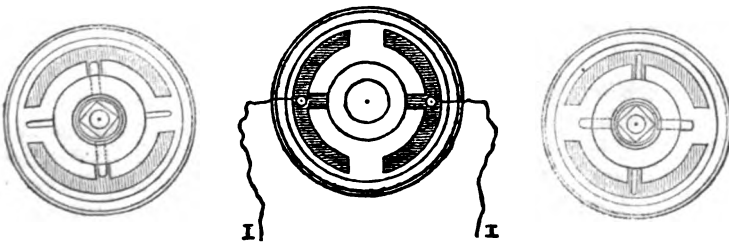

Fig 5.

Fig. 6.

Fig. 7.



plier, in consequence of which, the voltaic current preserves its sign as long as the multiplier is turned in one direction, but it

changes its sign on the motion being reversed. This commutation, which, it may be remarked, may be established without the use of mercury, by the contact of the strips of copper that act like springs, is found to answer completely. There are, besides, two other arrangements, which we must not allow to pass unnoticed.

The voltaic current, as we shall see in the sequel, when treating of the indicator, should only be permitted to be in action during as short a period as possible, but during the interval should have the greatest intensity that can be commanded. The terminal hooks of the wires dip into the quicksilver, only at the place where it forms pools that advance toward each other at the centre, and where the current is at its greatest intensity, as seen by figs. 5, 6, and 7. Fig. 5 shows the position that the inductor has, when the terminal hooks first dip into the cups. In all other positions of the inductor, it should, however, form no part of the chain or wires, otherwise the signals made at the other stations will be repeated by its own multiplying wire; and this becomes of the more moment the greater the resistance in the conductor. In order, therefore, to cut off the inductor, when in any other position than shown in fig. 5, there is a wooden ring adapted to the axis of rotation of the inductor, as seen in figs. 8 and 9. This ring is encircled with a copper hoop, and into this latter two iron hooks are screwed. These hooks

Figs. 8 & 9. dip down into the semi-circular cups of quicksilver, as shown in fig. 7. At the moment, however, that they are passing across the wooden partition, the hooks of the inductor, which are at right angles to them, dip into the cups. When the hooks of the multiplier are in contact with the quicksilver, the connection with the hooks for diverting the current is broken. In every other position, the connection through the hooks of the multiplier is interrupted, while it is established through the others; whence it naturally follows that the current, on being transmitted from any

other station, passes directly through the latter hooks, or, in other words, crosses directly from one quicksilver cup to the other, and is not forced to traverse the wire of the inductor for that purpose. In order to put the inductor in motion without trouble, there is a fly-bar terminating in two metal balls, fastened horizontally on to its vertical axis, as seen in figs. 1 and 10. To prevent the quicksilver from being scattered about, owing to the motion of the hooks as they dip into it, when the multiplier is turning rapidly, a glass cylinder is fitted on to this part

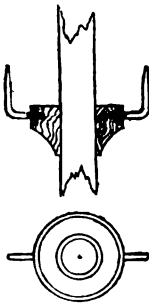

of the apparatus, fig. 11. At every half turn is seen the passage of the spark, as the hooks of the multiplier leave their cups of quicksilver.

Fig. 10.

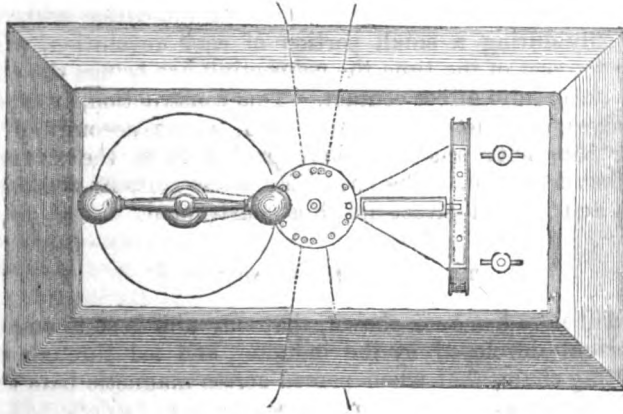

If we choose to give up the phenomena of these sparks—a thing nowise necessary to the employment of the instrument as a telegraph—the inductor will admit of a far more simple construction. It will then merely be necessary to place the

Fig 11.

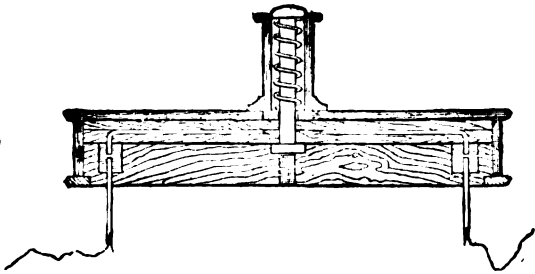

commutator directly above the anchor, and to let the axis of rotation pass farther up in the neck, in the direction of the fly-bar. It then becomes necessary to bore the axis out, but the ends of the multiplier are at once fastened by twisting on to two plates of copper, and these copper plates are let into a wooden ring, directly opposite to each other. The wooden ring is placed upon the vertical axis, and made fast to it by clamps. Externally this ring is, in addition to the above-mentioned plates, provided with an arc of copper let into it, which

acts as a contact-breaker, and two ends of the chain that the current has to traverse, have the form of permanent springs, that keep pressing against the wooden rings directly opposite each other. By this means, with this arrangement also, the ends of the inductor are in metallic communication with the chain only during a small portion of each revolution, while during the rest of the time the connecting arc brings the ends of the chain into direct contact. This construction, in which quicksilver is entirely dispensed with, is, on account of its greater simplicity and durability, preferable to the arrangement first described. The apparatus of the stations at Bogenhausen and in Lark-street are thus constructed.

THE INDICATING APPARATUS.

Hereinbefore has been shown, that our aim is so to employ the current developed by the inductor, and led through the conducting chain, that when passed across magnetic bars that are delicately suspended, it may cause them to be deflected, as was discovered by Ørsted. These deflections, if we wish to give the signals in quick succession, must follow each other with the greatest rapidity, and should therefore be powerful. This points out to us the size we should give the magnetic bars we wish to deflect. They must not, however, be made too small, as in that case the mechanical force arising from their deflection, is not strong enough to be directly applied to striking upon bells, or any other similar purpose. The deflections are, as is well known, taking the force of the current to be the same, the stronger, the greater the number of turns in the multiplier, or, in other words, the oftener the wire is led along the magnetic bar. The size of the diameter of the separate turns, as we know, only exerts an influence, inasmuch as it adds to the entire length of the connecting wire. The indicator, therefore, is a multiplier, whose two ends connect with the conducting chain, and within which the bar to be deflected is placed. It must be borne in mind, that the thinner the wire of the multiplier is, the larger its coils are, and the more turns they make, the greater is the resistance to the current throughout the entire chain.

Figs. 12 and 13 represent the vertical and horizontal sections of an indicator containing two magnets, moveable on their vertical axis, and which, from their construction, are applicable both to striking bells, and also for writing characters in the form of dots or points. These figures will be more particularly explained hereinafter, reference to their application being suf-

ficient for the present. Into the frames of the multiplier, which are made of soldered sheet brass, fig. 11, there are soldered two smaller cases for the reception of the magnets, and which allow of the reel motion of their axes. Above and below

Fig. 12.

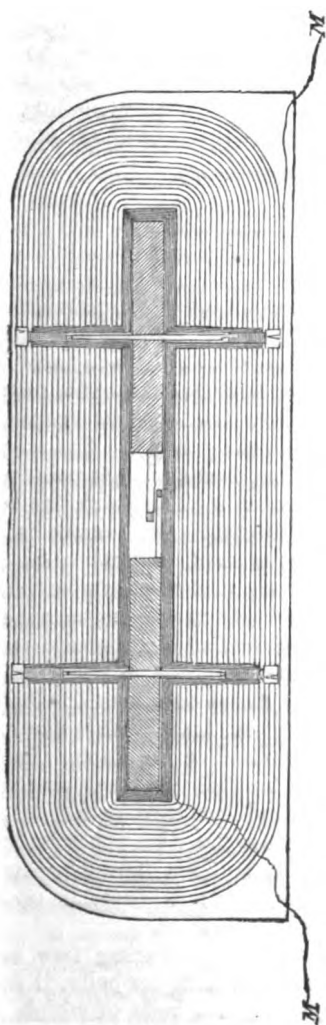
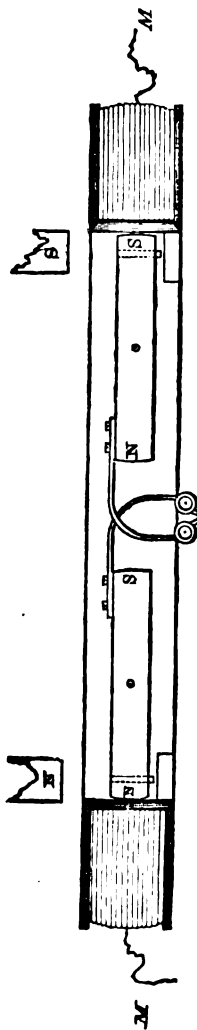

Fig. 13.



they have threads cut in them, for the reception of four screws in holes, on the ends of which the pivots of the axes turn. By means of these screws, the position of the bars may be so reg-

ulated, that their motion is perfectly free and easy. In the frames of the multiplier there are 600 turns of the same insulated copper wire as was employed for the inductor. The commencement and the end of this wire are shown at *MM*, fig. 12. The magnetic bars are, as the figures show, so situated in the frame of the multiplier, that the north pole of the one is presented to the south pole of the other. To the ends which are thus presented to each other, but which, owing to the influence they mutually exert, cannot well be brought nearer, there are screwed on two slight brass arms, supporting little cups, figs. 13 and 14. These little cups, which are meant to

Fig. 14.

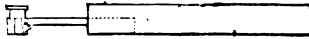

be filled with printing ink, or black oil color, are provided with extremely fine perforated beaks, that are rounded off in front. When printing-ink is put into these cups, it insinuates itself through the bore of these beaks, in consequence of the capillary attraction, and without running out, forms on the openings of the beaks a projection of a semi-globular shape. The slightest contact suffices, therefore, for writing down a black point or dot. When the voltaic influence is transmitted through the multiplying wire of this indicator, both magnetic bars make an effort to turn in a similar direction upon their vertical axis. One of the cups of ink would, therefore, advance from within the frame of the multiplier, while the other would retire within it. To prevent this, two plates are fastened at the opposite ends of the free space that is allowed for the play of the bars, and against which the other ends of these bars press. Only the end of one bar can, therefore, start out from within the multiplier at a time, the other being retained in its place. In order to bring the magnetic bars back to their original position as soon as the deflection is completed, recourse is had to small moveable magnets, whose distance and position are to be varied, until they produce the desired effect. This position must be determined by experiment, inasmuch as it depends upon the intensity of the current called into execution.

If this apparatus be employed for producing two sounds easily distinguishable to the ear by striking on bells, it will be right to select clock-bells or bells of glass, both of which easily emit a sound, and whose notes differ about a sixth. This interval is by no means a matter of indifference. The sixth is more easily distinguished than any other interval; fifths and

octaves would be frequently confounded by those not versed in such matters. The bells are to be supported on little pillars with feet, and their position with respect to the bars, and likewise their distance from them, is to be determined by experiment. The knobs let into the bar that strike on the bells must give the blow at the place which most easily emits a sound. These hammers, however, are not to be too close to the bells, as in that case a repetition of the signal can easily ensue. A few trials will soon get over this difficulty. If the indicator is to write down the signal, a flat surface of paper must be kept moving with a uniform velocity in front of the little beaks before mentioned. The best way of doing this is to employ very long strips of the so-called endless paper which is to be wound round a cylinder of wood, and then cut upon the lathe into bands of suitable widths. One of these strips of paper must be made to unwind itself from a cylinder, pass close in front of the cups, run along a certain distance in a horizontal position, so that the dots noted down may be read off, and lastly, wind itself up again on to a second cylinder. The second cylinder is put in motion by clock-work, the regularity of whose action is insured by a centrifugal fly-wheel. A longitudinal section of the entire arrangement is shown by fig. 1. Fig. 10 represents it as seen from above. At the corners of the frame over which the ribbon of paper is led, there are placed two moveable rollers, to diminish the friction. The frame moreover admits of being advanced toward the cups or withdrawn from them, so that the most proper position to give it can be ascertained by experiment. It is evident that the same magnetic bars cannot be at once employed for striking bells and for writing, the little power they exert being already exhausted by either of these operations. But to combine them both, all we have to do is to introduce a second indicator into the chain. By thus increasing the number of the indicators, the loudness of the sounds of the bells can be augmented at pleasure: this can, however, only be done at the expense of an increased resistance in the chain. In order that this may be increased by the indicator as little as possible, it would in future be better that its coils should be made of very thick copper wire, or of strips of copper plate.

CONSTRUCTION OF THE APPARATUS.

The longitudinal section of a pyramidal table, standing on the floor of the room, and containing the whole apparatus is represented by fig. 1. Fig. 10 shows the same as seen from above. The wires from Bogenhausen, those from the Lark-

street, the ends of the indicator, and the wires from the quicksilver cups of the inductor, or, in other words, the two ends of the multiplier, all meet together at the centre of the table, as seen in fig. 10. They are here brought into connection with eight holes filled with quicksilver, made in a disk of wood as shown by fig. 15. The course that the

Fig. 15.

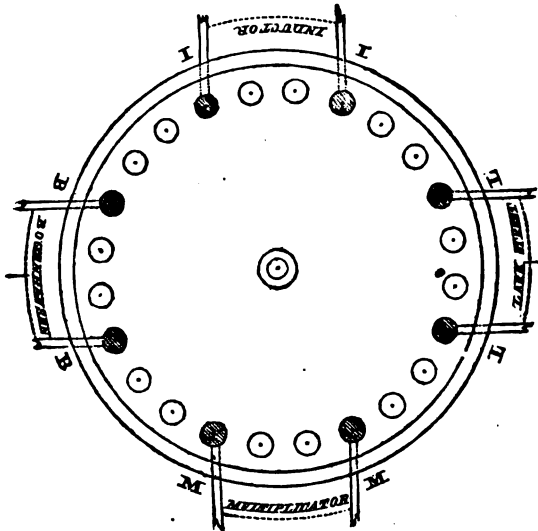

current we call forth will take depends upon the respective connections of these eight holes with each other. For example, suppose them to be connected together by four pieces of bent copper wire, as shown at fig. 15, the current would pass through the whole apparatus, and also, the entire chain. Establishing,

Fig. 16.

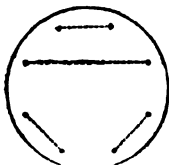

however, the connection as shown by fig. 16 would cut off the Bogenhausen station, and would at once transmit the current direct from the inductor, through the multiplier of the indicator and through the Lark street station. Supposing this figure turned around 180 degrees, we should have the Lark street station cut off, and the current would pass through Bogenhausen. A third system of connections is shown by the copper wires represented in figs. 17 and 18. In this position of the sketch, the inductor and the multiplier would be in direct communication, while the two stations at Bogenhausen and in the Lark street would be cut off. But by turn-

Fig. 17.

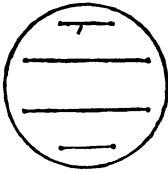
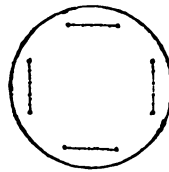
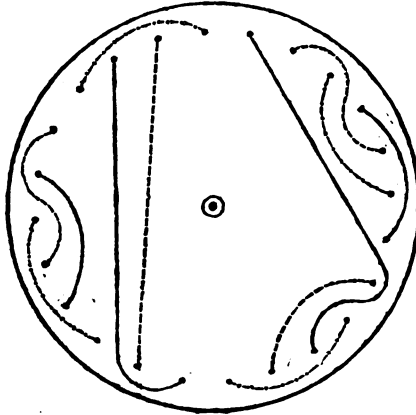

Fig. 18.



ing this figure 90° , we should connect these two stations, while we broke off the station in the Academy. Copper wires serving to establish these three systems of the connections and the combinations, are laid down upon the under surface of the wooden cover of the commutator, as seen at fig. 19,

Fig. 19.



There are twenty-four wires projecting downward from this lid. Only eight of them, however, ever come into use at once, so that there must be sixteen other holes made in the lower disk of wood, for the reception of the wires not in use, and having no quicksilver poured into them. It is thus in our power to direct the course of the current as we choose, and the systems concerned are indicated upon the upper surface of the cover of the commutator by engraved letters, as seen by fig. 20; this cover containing the different modifications of the systems of connection, as shown at fig. 19. Changing the position of this cover round the central pin springing from the table, enables us to vary the direction of the current in any manner we like. The use of the quicksilver cups in the commutator may of course be replaced by conically turned copper pins. This has indeed been done at the Lark-street and the Bogenhausen stations.

Fig. 20.

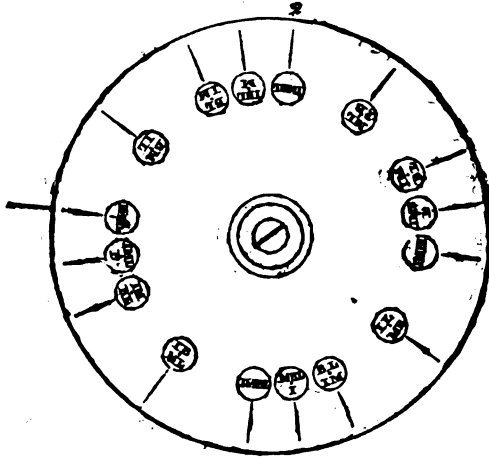

APPLICATION OF THE APPARATUS TO TELEGRAPHING.

From what has already been stated, it will be seen that at every half turn of the fly bar from right to left, one of the bars is deflected. The terminations of the wires are so connected that every time this movement is repeated the high-toned bell should be struck at all the stations. Standing at the side *B B*, and turned toward the indicator, one immediately perceives the beck imprint a dot upon the ribbon paper as it moves along. The intervals of time between the successive repetitions of this sign, are represented by the respective distances between the dots that follow in a line upon the paper. On turning the fly-bar from left to right toward the operator, the deep-toned bells ring, and the second ink cup marks down a dot upon the paper as before, not, however, upon the same line with the former dots, but upon a lower one. *High* tones are therefore represented by the *upper* dots, and the *low* tones by the dots on the lower line, as in writing music. As long as the intervals between the separate signs remain equal, they are to be taken together as a connected group, whether they be pauses between the tones, or intervals between the dots marked down. A longer pause separates these groups distinctly from each other. We are thus enabled by appropriately selected groups thus combined, to form systems representing the letters of the alphabet or stenographic characters, and thereby to repeat and render permanent at all parts of the chain, where an apparatus like that above described is inserted, any information that we transmit. The

alphabet which is chosen represents the letters that occur the oftenest in German by the simplest signs. By the similarity of shape between these signs and that of the Roman letters, they become impressed upon the memory without difficulty. The distribution of the letters and numbers into groups consisting of not more than four dots, is shown in the alphabet, figs. 23 and 24.

In order to explain more definitely figs. 12 and 13, the following figs. 21 and 22, with their sectionals more particularly described, are inserted.

Fig. 21.

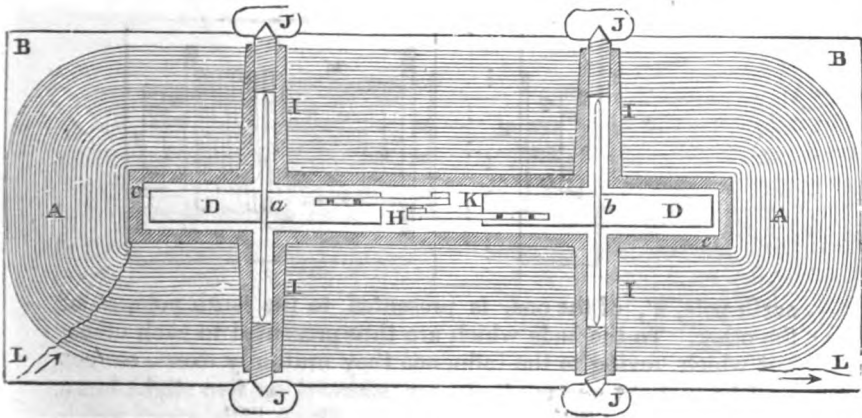

In fig. 21, A A represents a vertical section, through the centre of the coil of copper wire; c is the interior brass frame, round which the wire is wound; B B are the sides of the frame; I I I I are four brass tubes, soldered to the interior brass frame, and passing through the centre of the coil to its exterior, with a screw cut in the end of each; D and D are two permanent magnets movable on their axis *a* and *b*. These spindles, *a* and *b*, on each side of the magnets, pass up the hollow of the tubes, and having their ends pointed, enter the centre cavity of the four thumb screws, J J J J, by which they are supported, and delicately adjusted, so as to move easily and freely; L and L are the ends of the wire leaving the coil; H and K are two ink-holders, attached to the magnets, which will be explained hereafter.

Fig. 22 represents a horizontal section of the coil, and magnets D' and D', as above described, together with the other arrangements of the instrument for receiving intelligence. The magnetic bars are so situated in the frame of the multiplier, that the

Fig. 22.

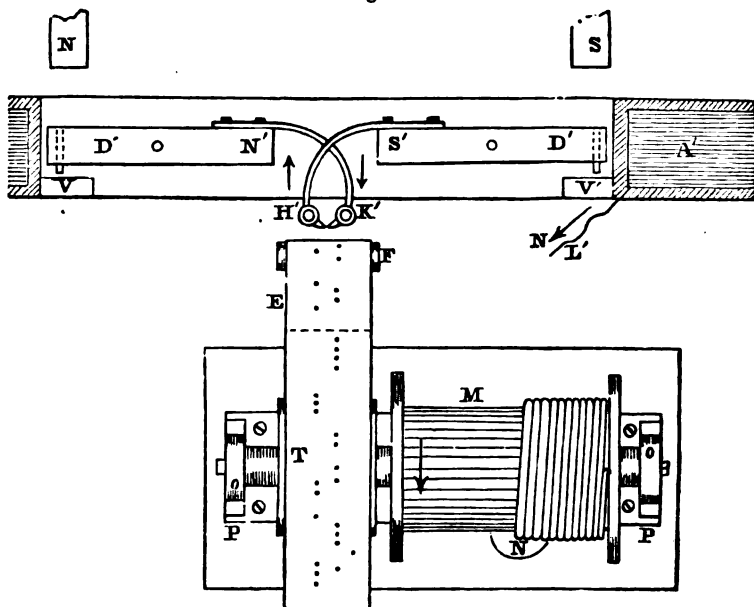

north pole, n' , of the one, is presented to the south pole, s' , of the other. To the ends which are thus presented to each other, but which, owing to the influence they mutually exert, cannot well be brought nearer, there are screwed on two slight brass arms, supporting little cups, h and k . These little cups, which are meant to be filled with printing ink, are provided with extremely fine perforated becks, that are rounded off in front. When printing ink is put into them, it insinuates itself into the tube of their becks, owing to capillary attraction; and, without running out, forms at their apertures a projection of a semi-globular shape. These little cups are seen at h' and k' , and in fig. 21 at h and k . The horizontal section shows, also, the position of the magnets in the instrument, with the becks of the pens near the continuous band, or ribbon of paper, e , which is brought in front of the pens vertically from below, over a small roller, f . The paper is supplied from a large roll on a wooden cylinder, upon which is a cog-wheel, and connected with a train of wheels and a vane, to regulate the rate of supply. The paper is drawn along before the pen by being wound upon a cylinder, t , concealed by the paper, and on the same shaft with the barrel, m , upon which is wound a cord supporting a weight, n , below. The shaft is supported in the standards, o and o , which are fastened to a plate of brass, p and p , also secured to the

platform of the instrument. The barrel revolves in the direction of the arrow upon it.

When the electricity is transmitted through the coil of the indicator, both magnetic bars, d' and d'' make an effort to turn in a similar direction upon their vertical axes, a and b . One of the cups of the ink, therefore, advances toward the paper, while the other recedes. To limit this action, two plates, v and v' , are fastened at the opposite ends of the free space allowed for the play of the bars, and against which the other ends of the bars press. Only the end of one bar can, therefore, start out from within the multiplier at a time, the other being retained in its place. In order to bring the magnetic bars back to their original position, as soon as the deflection is complete, recourse is had to two small moveable magnets, a portion of which is seen at n and s , whose distance and position are to be varied till they produce the desired effect.

The fluid is made to pass in the direction of the arrows, shown at p and m . Then the n pole of the left-hand magnet advances with its pen k' , to the paper e , and a dot is made, and the s pole of the right-hand magnet recedes with its pen h from the paper, until the other end of the magnet strikes the stop v' . Now, if the letter to be formed requires two dots in succession from the same pen, the circuit is broken, and the fixed magnets, n and s , bring back the deflecting magnets, d' and d'' to their former position, when the pole-changer is again thrown to the left, and the magnets are deflected in the same manner, as at first. Thus, two dots are marked upon the paper, on the *right* hand line. When the current is reversed, the n pole of the left-hand magnet, with its pen k , recedes from the paper, until it strikes the stop v , and the s pole of the right-hand magnet, with its pen h' , advances to the paper, and makes its dot upon it on the *left*-hand line.

THE ALPHABET AND NUMERALS.

The alphabet was formed, as has been already described, by the making of dots upon a ribbon paper, from small becks holding ink in globular forms at their ends. The alphabet thus written is arranged by some authors as follows :

Fig. 23.

A B D E F G H C H S C H I K L M N O P R S T V W Z
Λ X \ . P Y ^m N . J L ^m " u V u J / Y V L

Prof. Steinheil has furnished me with the alphabet and nu-

erals arranged as the following, which must be regarded as their true and proper organization.

Fig. 24.

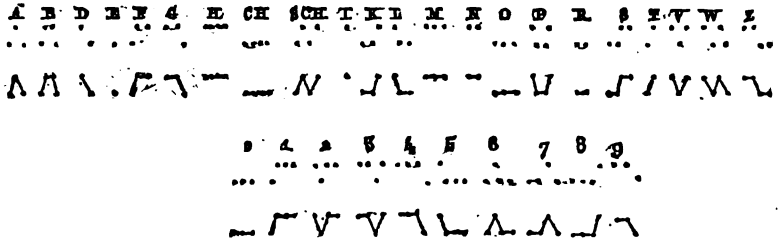

THE DISCOVERY AND INVENTIONS OF STEINHEIL.

From the foregoing, in regard to the discovery and inventions of Prof. Steinheil, it will be observed that he produced the following facts, viz.:

1st. That he invented a tangible and practical writing electric telegraph, demonstrated by the most complete experiments;

2d. That he invented an electric telegraph, which actually communicated intelligence by sound, methodically arranged, suitable for commercial purposes;

3d. That he discovered the earth circuit, as practically applied in the electric telegraphic art, with all systems throughout the world

4th. That he first organized the system of poles and insulators, for the suspension of metallic conductors in the air for electric telegraphing;

5th. And that he established the fact, by actual experiment, that a current of electricity, generated by a magnetic organization, can be practically applied for telegraphing.

HISTORY OF THE ENGLISH ELECTRIC TELEGRAPH

CHAPTER XIII.

William Fothergill Cooke and the Telegraph—Möncke's Electrometer Experiments—The English Electric Telegraph invented—Invention of the Alarm—The Mechanical Telegraph—The Escapement Apparatus—Mr. Cooke's Efforts to put his Telegraph in Operation—The Second Mechanical Telegraph—Wheatstone's Permutating Key-Board—Messrs. Cooke and Wheatstone become associated—The Secondary Circuit invented—Mr. Cooke improves his Original Telegraph—All the Improvements combined—Description of the Apparatuses—Improvements patented in 1838—Wheatstone's Mechanical Telegraph—Further Improvements by Mr. Cooke.

WILLIAM FOTHERGILL COOKE AND THE TELEGRAPH.

THE English Electric Telegraph, invented by William Fothergill Cooke, will be the subject of consideration in the present chapter.

It is not my purpose to discuss the questionable claims of others, in regard to their participation as auxiliaries in the perfection of the above-mentioned telegraph. It is my purpose to give the facts with but little comment. The reader can exercise his own judgment in the premises.

In the month of March, 1836, Mr. Cooke was engaged at Heidelberg in the study of anatomy, in connection with the interesting, and by no means unprofitable profession of anatomical modelling; a self-taught pursuit, to which he had been devoting himself with incessant and unabated ardor. On the 6th of March, 1836, he witnessed an electro-graphic experiment, exhibited by Professor Möncke of Heidelberg, who had, perhaps, taken his idea from Gauss. Mr. Cooke was so much struck with the wonderful power of electricity, and so strongly was he impressed with its applicability to the practical transmission of telegraphic intelligence, that, on that very day, he entirely abandoned his former pursuits, and devoted himself

henceforth with great ardor, to the practical realization of the electric telegraph.

Professor Möncke's experiment was the only one, at that time, upon the subject of telegraphing, that Mr. Cooke had seen. To him the subject was new and surprisingly novel. The experiment which he saw showed that the electric currents, being conveyed by wires to a distance, could be there caused to deflect magnetic needles, and thereby to give signals. It did not provide any means, however, to practically effect telegraphic purposes. It was but a demonstration of science without a devised appliance in the arts.

MÖNCKE'S ELECTROMETER EXPERIMENTS.

Fig. 1.

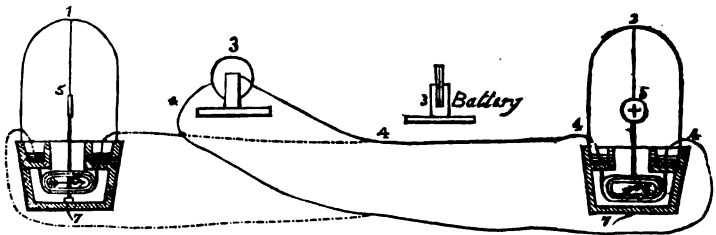

The apparatus exhibited by Professor Möncke, consisted of two instruments for giving signals by a single needle, placed in different rooms, with a battery belonging to each, copper wires being used as the conductor. Fig. 1 represents the apparatus used by Professor Möncke. Numeral 1 is the near and 2 the distant electrometer; 3 is the battery; 4, the conducting or circuit wire; 5, the signal; 6, 6, the electrometers, with magnetic needles, and at 7, 7, are steady pieces, dipping in a steadying cup of mercury, to support the needle and check oscillation. The signals given, 5, 5, were a cross and a straight line, marked on the opposite sides of a disk of card, fixed on a straw; at the end of which, a magnetic needle was suspended horizontally in an electrometer coil, by a silk thread. The effect of this arrangement was, that if a current was transmitted from either battery when the opposite ends of the wires were in connection with the distant telegraphic apparatus, either the cross would be there exhibited by the motion of the needle one way, or the line by its motion the other way, according to the direction of the current. The apparatus was worked by moving the ends of the wires backward and forward between the battery and the coils.

THE ENGLISH ELECTRIC TELEGRAPH INVENTED.

After Mr. Cooke had witnessed the experiment upon the above described arrangement, he devoted himself to the perfection of a contrivance to effect practically the ends of telegraphing, and within three weeks thereafter, he had, partly at Heidelberg and partly at Frankfort, completed a device for telegraphing, based upon the electrometer form, which, in principle, was the same as the English needle telegraph that has been for many years practically operated in Great Britain. Six wires were used, forming three metallic circuits, and influencing three needles, by which an alphabet of 26 signals was devised. The mechanical and scientific combinations produced a perfect reciprocal telegraphic system, by which a mutual communication could be practically and conveniently carried on between two distant places; the requisite connections and disconnections being formed by pressing the fingers upon the keys, and the signals were exhibited to the person sending them, as well as the person receiving the communication. This important end was effected, by placing a system of keys permanently at each extreme end of the metallic circuit, and by providing each circuit with a cross-piece of metal for completing the continuity of the wires when signals were being received from the opposite terminus. The two signal apparatuses being thus thrown into the course of the electric circuit, every signal was given at both ends concurrently; and the cross-piece was made to restore the circuit for a reply, on the first communication being completed. The system of keys and signal-levers were joined together in the one instrument, so that the pressure upon the key at either station, produced the signal intended at the receiving and sending stations.

Fig. 2.

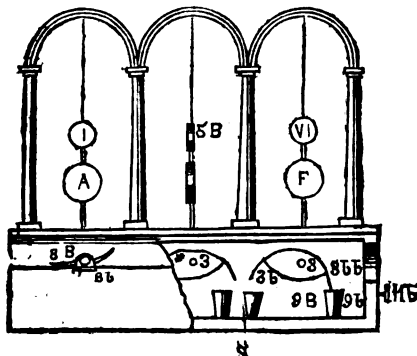

The apparatus devised by Mr. Cooke to consummate the system of reciprocal telegraphing was simple, and will be understood by studying figures 2, 3, 4, 5, 6, 7, and 8. The whole are parts of the same combination, and the same letters and numerals represents the like parts in the different and respective figures, thus 5 B, represents the same device in fig. 2 that they do in fig. 6.

The apparatuses represented by these figures constituted Mr. Cooke's "reciprocal electrometer communicator."

Fig. 3.

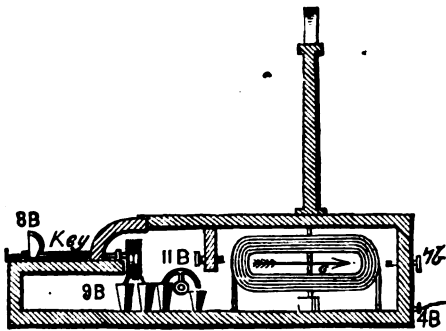
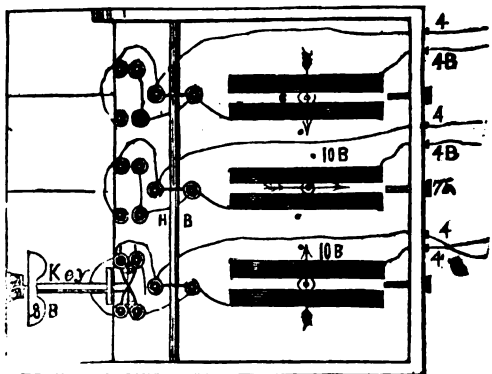

Figure 2 is the near station of the reciprocal telegraph, and fig. 6 the distant station. The battery is represented at the base of fig. 2, and upon a larger scale by fig. 7; 3b, 3bb, are commutating battery pole bars, for connecting the battery with the conducting or line wires on the pressure of the keys—3b is the

copper, and 3bb the zinc poles of the battery 4, 4B, are the telegraph wires, called by Mr. Cooke, the electrometer or reciprocal telegraph wires, because they were attached to electrometers at each end. 5B is a complete set of 26 simple and compound signals. 7b are iron screws for steadying the needles; 8B are communicator keys for uniting the ends of the conducting wires with the poles of the battery, so as to make the current pass in either direc-

Fig. 4.



tion through the conducting wires. The battery seen in fig. 2 is represented in larger scale by fig. 7; and, in fig. 8, a top

view of it is given. The key 8B, fig. 8, is given on a larger scale with all its parts; the zinc and the copper bars. 9B, 9b, represents the current commutator for reversing the direction of the electric current; 9B, is the zinc, and 9b, the copper. The line wires and the electrometer as connected with the battery are fully represented in fig. 8. The key represented in fig. 8, is an axle with lever arms, 8B. If the finger presses upon 8B the axle turns, and the connections with the upper cups, fig. 8, are made by the wires attached to the zinc and the copper bars. If the lever on the other side of the axle be pressed, the lower battery, fig. 8, is put into the circuit. If the reader will refer to the keys of the present instruments of the

Fig. 5.

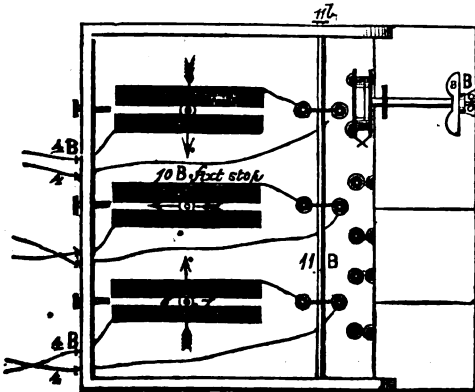

English telegraphs, the same principles will be seen in their organization as represented by fig. 8.

In figures 4 and 5, 10B represent fixed stops, or pins, designed to prevent the needles from oscillating too far. 11B is a moveable cross piece, and 11b its handle.

Fig. 6.

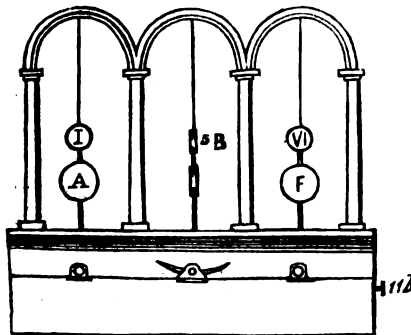

The manipulation of the apparatus was very simple and easy. In order that the operation may the better be under-

stood by the reader, I will trace the route of the current and show its action, resulting in the perfect transmission of telegraphic communication. Figures 4 and 5 are two end stations, 100 miles apart, at each of which are the instruments represented in the figures. The line wires are seen to the right of

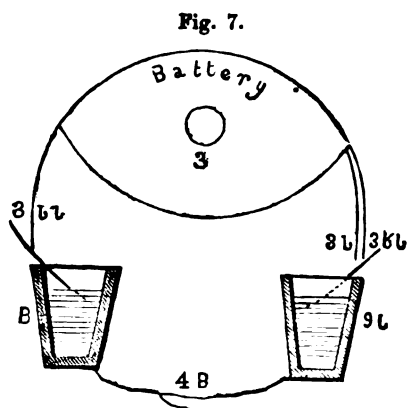
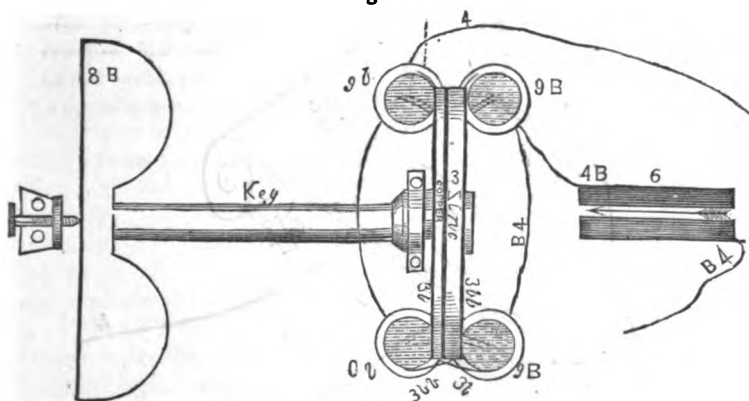

fig. 4, and to the left of fig. 5, marked 4, 4. If the key 8B, fig. 4, is pressed, making the battery current flow over the line, the needle suspended in the coils 10B, will be deflected to the position as seen in the figure, being at right angles to the normal position of the needle, as seen by the middle needle in the same figure. The needle in the terminal station coils, fig. 5, will assume the same position indicated in fig. 4. The electrometer was made in the usual form, and the needle being magnetic, it would move to the right or to the left according to the nature of the current transmitted through the coils, determined by the pressure upon the key, whether upon the right-hand side or upon the left-hand side. The needles of the centre coils are in their normal state. The upper needles are deflected, reverse to those in the lower coils. The position occupied by one may be A, and that by the other B. Two motions, either direction of the needles, another letter and so on, completing the whole combination forming the alphabet.

Besides the arrangement above described, Mr. Cooke invented an apparatus, styled by him a "detector," for discovering any injury done to the conducting wires by water, fracture, or contact. The arrangement was an application of a gauged electrometer.

The foregoing is a fair description of the first electrometer telegraph, invented by Mr. Cooke, between the 9th and 15th

Fig. 8.



of March, 1836. So energetic and successful was Mr. Cooke in the perfection of his telegraph, that within three weeks after he saw the experiment of Möncke, he had the model of his reciprocating telegraphic system in operation.

INVENTION OF THE ALARUM APPARATUS.

Before the end of March, 1836, Mr. Cooke invented the apparatus known as the alarum, which is still extant, in his first mechanical telegraph. The arrangement was of ordinary combination, worked by clock-work mechanism, on the removal of a detent. The invention consisted in placing an electro-magnet in such proximity to an armature of soft iron forming the tail end of a lever detent, that when an electric current passed round the electro-magnet, the magnetism which was, for the moment, excited in it, attracted the tail end of the lever, and by so doing, drew its detent end out of the clock-work; but, on the temporary magnetism ceasing with the cessation of the current, the attraction of the tail-end of the lever ceased also, and the detent-end of it was then replaced in the clock-work by a re-acting spring or balance weight. The principle of removing a detent, by magnetic attraction, and replacing it by mechanical re-action, was not, however, confined to the alarum, but, on the contrary, it was the basis of Mr. Cooke's mechanical telegraphic system, hereinafter described.

THE MECHANICAL TELEGRAPH INVENTED.

In the invention of the mechanical telegraph, Mr. Cooke applied the idea to a musical snuff-box, and in less than six weeks from the time he saw the experiment of Professor

Fig. 9.

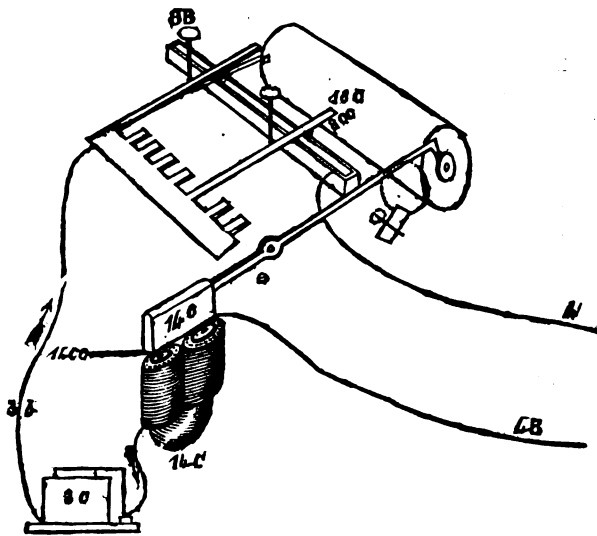
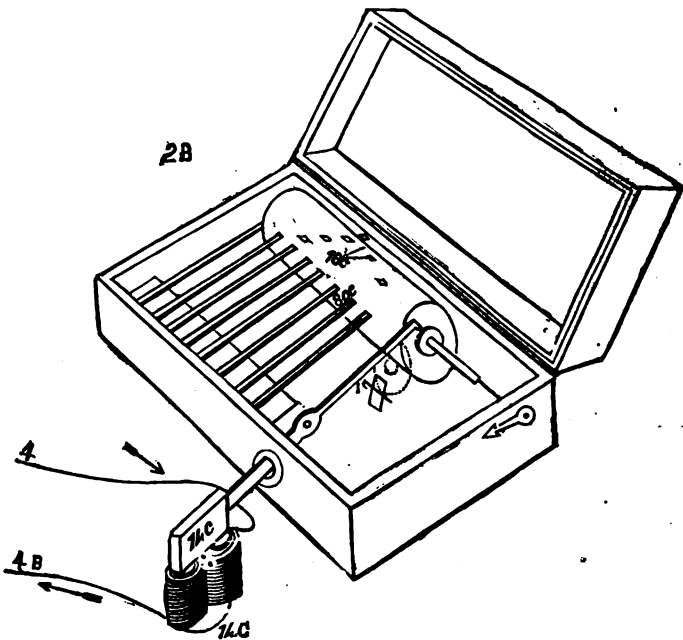

Fig. 10.



Möncke, he had invented his mechanical system. Mr. Cooke considered that the striking advantage held out by the mechanical, in comparison with the electrometer form was, that, whereas the mode of giving signals by combination of magnetic needles, each acted upon directly and separately by an electric current, involved the necessity of using several circuits, and consequently the expense of several wires; on the other hand, if the electric agency could be confined to the office of causing suitable interruptions or divisions in any kind of motion derived from an independent source, the necessity of a plurality of circuits would be avoided, for the diversity of signals would then depend upon the mechanism.

Figures 9 and 10 represent the mechanical telegraph, as devised upon the principles of the musical snuff-box.

The electro-magnets, 14c, of the respective stations, are seen in the figures; 3, the battery; 14c, are the armatures of the magnets to which are attached the detent levers; 4 and 4B are the line wires, and the arrows indicate the course of the current. The circuit, as arranged in figs. 9 and 10, is opened and closed by the action of the apparatus of fig. 9. Pressure upon the keys completed the electric circuit; which magnetized the cores of the electro-magnets, the armatures were then attracted, which drew down one end of the detent lever, and elevated the other end, drawing it out of the train of wheels, and allowing the mechanism to move on by its own maintaining power, till the intervention of an appropriate pin, 18c, fig. 10, upon the cylinder or barrel, struck up the key, *See*, the circuit was then broken. When broken the magnetism ceased to exist in the cores of the spools, therefore, an end was put to the attraction of the armature end of the detent lever, and the re-acting spring drew the lever, so as to place the detent in its normal position, which put a stop to the mechanism, at the time when the revolving dial was presenting before an opening in the frame of the apparatus at each terminus, the requisite letter, figure, or symbol. The signal to be made was determined by the proportion of a revolution which the barrel was allowed to make without interruption; therefore, although some latitude was allowed for a variation in the speed of the different apparatuses, the successful transmission of intelligence depended, to a certain extent, upon a similarity of timing; any great variation of time would introduce confusion into the signals, and in proportion to every increase in the speed at which the signals were given, the latitude allowed for variations would become actually less, though remaining relatively the same; consequently, in proportion to the increased

rapidity of a succession of signals, greater accuracy of mechanism would be required. If the signals could be given by divisions of the mechanical motion similar to the divisions made by the escapement of a clock, the necessity of accurate timing would be altogether avoided, for it would then be only necessary that every intervention of the attractive force of the magnet, should occasion or allow a motion of the armature or

Fig. 11.

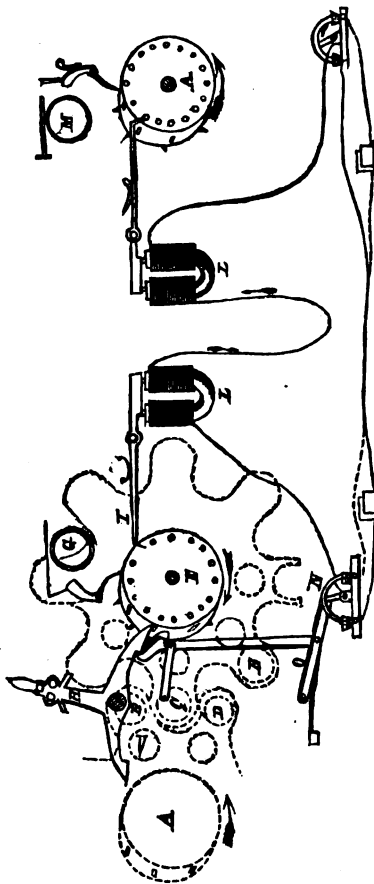

pallet of each escapement, without its being necessary that a motion of the pallet should occupy, in each instrument, precisely the same period of time.

Fig. 11 is an extension of the telegraph, based upon the plan of the musical snuff-box. The engraving is an outline view of the mechanism. The parts in fig. 11 are indicated by different letters from those used in figs. 9 and 10. In the former *A A* are the cylinders or barrels containing the keys; *M* is the alarm bell; *L L* the magnets; *B, C, D,* and *E,* are the ends of various cylinders.

I do not deem it necessary to give a detailed description of the mechanical arrangement of the apparatus, believing that sufficient has been shown to enable the reader to understand the general plan. It is the first mechanical telegraph invented by Mr. Cooke, in March, 1836.

THE ESCAPEMENT APPARATUS.

In July, 1836, Mr. Cooke produced his experimental escapement instrument, represented by figures 12 and 13, based upon the principle of the vibrating pendulum, alternately retained by one of two magnets, on the same conducting wire,

actuated by an escapement wheel, the signal being given by an index hand.

A A are two electro-magnets, alternately detaining the detent, to which are attached the armatures of the magnets; to the right and left of the letter c, is the alternating detent in the form

Fig. 12

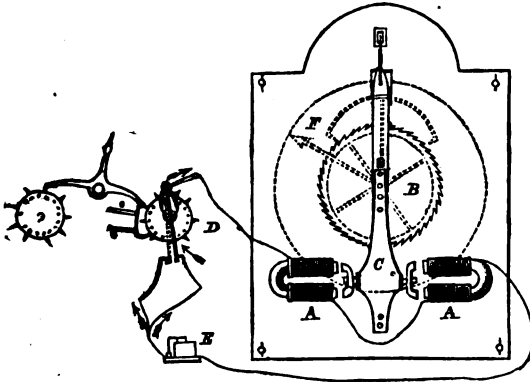

of an anchor escapement, stopping the clock-work by catching the teeth of the scape wheel, B. c is the detent-lever attached to the armatures; F is the revolving hand pointing to the sig-

Fig. 13

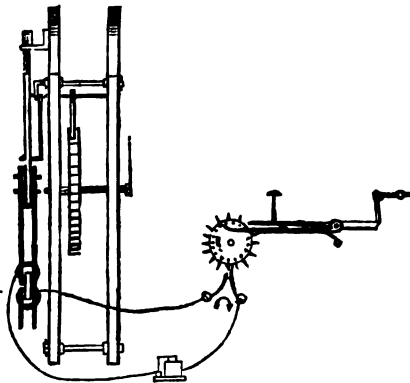

nals. Figure 13 is an end view of figure 12, in which are seen the magnets at the left, the scape wheel, B, in the centre, and the index hand is on the right.

MR. COOKE'S EFFORTS TO PUT HIS TELEGRAPH IN OPERATION.

Having thus perfected his various plans of the electric telegraph, Mr. Cooke, in the latter part of 1836, directed his attention toward the application of his invention on the Liverpool and Manchester railway. To this end, he issued a pamphlet, presenting the advantages of his telegraph, its plan of operation and construction, and its utility for the railway service; and particularly having in view the practical adoption of his telegraph in tunnels, for which some mode of conveying signals was required. The directors of the railway company, thought his instrument, which was calculated to give 60 signals, of too complex a nature for the purpose of conveying a few signals along a tunnel, and therefore they proposed to Mr. Cooke, that he should arrange one adapted for their purposes.

With the object of accommodating the wants of the railway service, Mr. Cooke proceeded to devise a system of telegraphing, calculated to give fewer signals and much less complicated. This, however, was done, but upon the principles of the first mechanical telegraphic apparatus.

THE SECOND MECHANICAL TELEGRAPH.

Figures 14 and 15 represent the second mechanical telegraphic apparatus, on which was employed only two wires. It was invented by Mr. Cooke, 10th of February, 1837; two of which he had working together in the following April. The figures represent two different stations; *a c* are the electro-magnets; *4*, the line wire; *3c*, the batteries; *4c*, the armatures of the electro-magnets, to which are attached the detent levers; *10E*, are fan wheels by which the detent arrests the mechanism; *16e*, is the detent to catch the fan wheels. The action of the different parts of this apparatus is the same as the like parts of figures 9, 10, and 11. This apparatus was perfectly qualified to perform the intended service at the railway tunnels, but in the meantime a pneumatic apparatus was laid down, which superseded the electric appliance; the former was supposed, by the directors, to be better than any system operated by electricity. It was at a time when there were none of the arts operated through the agency of voltaic force, and the railway company were not disposed to experiment upon that which to them seemed, as the vision of a dream. Mr. Cooke, however, was not to be crushed by this failure, and he proceeded to perfect his knowledge in the science of electro-magnetism, endeavoring to ascertain at what distance an electric current would excite the temporary mag-

netism required for moving the detent of the mechanism. His experiments were not, to him, satisfactory, and he sought the advice of Prof. Faraday, and then Dr. Roget. This latter gentleman referred him to Professor Wheatstone, of King's College. Mr. Cooke lost no time in making the acquaintance of Prof. Wheatstone, which took place on the 27th day of February, 1837. The two gentlemen discussed the subject of telegraphing, freely, and Prof. Wheatstone exhibited to Mr. Cooke

Fig. 14.

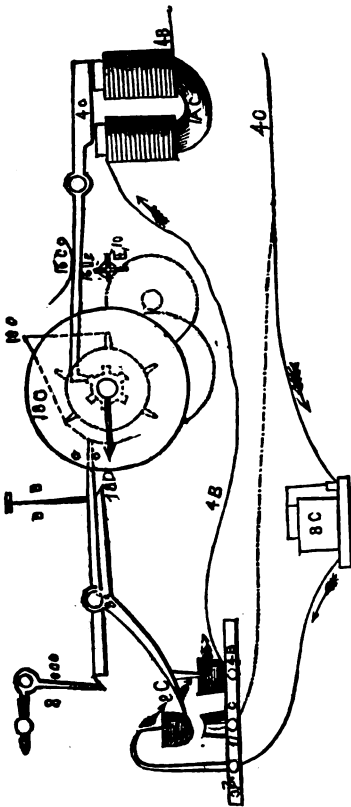
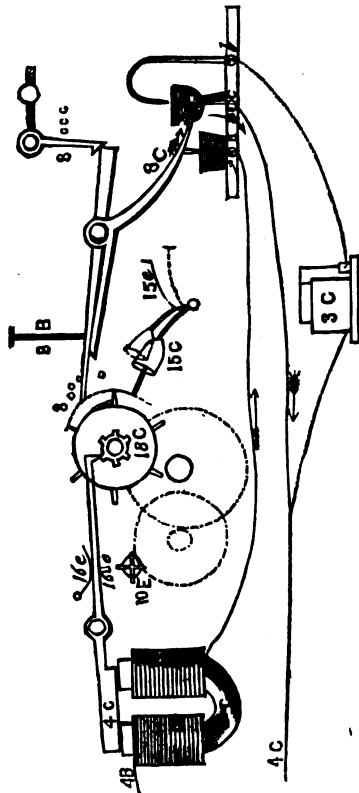
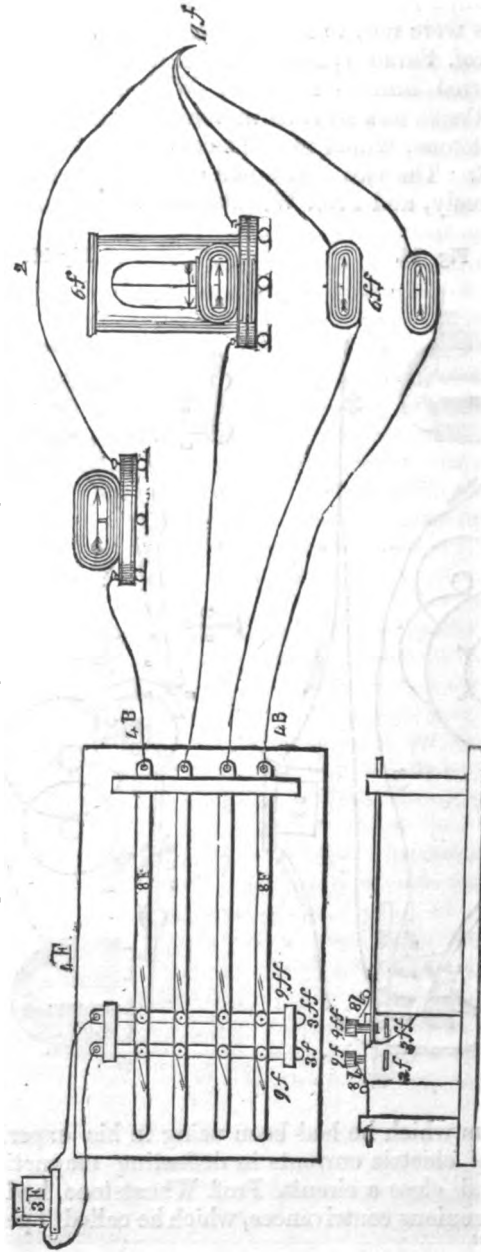

Fig. 15.



an apparatus which he had been using in his experiments on the effects of electric currents in deflecting magnetic needles. To open and close a circuit, Prof. Wheatstone had arranged two very ingenious contrivances, which he called "permutating boards."

Fig. 16.—Permutating Key-Board invented by Prof. Wheatstone.



This ingenious contrivance was used by Prof. Wheatstone in the latter part of the year 1836, in his room at King's College. About the same time he publicly expressed an opinion that an electric telegraph was possible.

WHEATSTONE'S PERMUTATING KEY-BOARD.

This contrivance was used by Prof. Wheatstone, in his electrical experiments, transmitting different currents over long wires. It was arranged to send a current over any one of the four wires, represented in figure 16. 4F, is the near key-board; 4B, are wires attached to the keys, and extending through the electrometer, 6f, and uniting beyond at 11f; 6ff, were electrometers *designed* to be applied; 3F, is the battery designed to be applied to the several circuits as circumstances required; 3f, 3ff, are fixed pole bars. The section below, gives an end view of the key-board. At that time, this contrivance was one step toward a telegraph, though in its invention, Prof. Wheatstone, it seems, did not contemplate the invention of a telegraphic apparatus. His mind and experiments were directed toward the advancement of the sciences, leaving to others the application of his discoveries to the useful arts. The principle contemplated, was to give a complete set of signals at a distance, by the motion of two or more horizontal magnetic needles, with permutating keys and commutating pole bars; giving the maximum number of signals by the minimum number of wires required for the electrometer telegraph; thus, the closing of the circuit at the key-board, transmitted a current of electricity, from the voltaic battery, over the wire, and caused the needle of the electrometer to move. It seems, however, that he had not had in view any arrangement for detecting injuries to the wires, of attracting attention at the commencement of the communication, of sending signals alternately backward and forward by the same apparatus, and of exhibiting signals to the operator, as well as to the recipient. But this deficiency in the plans of Prof. Wheatstone, was not surprising. He was in the pursuits of science, expecting no other reward on account of his discoveries, than the consciousness of having advanced science, and the pleasure realized in the discovery of new truths, and the scientific reputation. Such were the sentiments entertained by the philosopher of whom I am now writing.

Mr. Cooke was not so imbued. He was not a discoverer, but an inventor.

MESSRS. COOKE AND WHEATSTONE BECOME ASSOCIATED.

In the short acquaintance which Mr. Cooke had with Professor Wheatstone, he found cause to admire his great learning, and particularly his knowledge of electricity and electromagnetism, and he urged Prof. Wheatstone to co-operate with

him in the advancement of his invented telegraph, confidently believing, that if he had the influence of the scientific recognition of Prof. Wheatstone, his telegraph would command favor. The world at that time was ignorant of the wonderful powers of the electric and magnetic forces for telegraphing. The new art needed the aid of scientific encouragement, and Mr. Cooke believed, that in getting associated with him Prof. Wheatstone, and the influence of his scientific friends, the telegraph would not only be a success in the opinions of scientific gentlemen, but also as a commercial enterprise. Like all high-toned scientific gentlemen, Prof. Wheatstone refused the association, because, as he said, in substance, he preferred to publish the results of his experiments, and then to allow any person to carry them into practical effect, and that, in the position he stood, to associate his name with that of any other person, would diminish the credit which he would obtain by publishing separately the results of his own researches. But, as Mr. Cooke was not seeking scientific reputation, he assured Prof. Wheatstone, that there would be no interference in that respect. In substantiation of the correctness of these statements, reference may be made to the award given by Messrs. Brunel and Daniell, and which award was approved by Messrs. Cooke and Wheatstone; it emphatically says, "Mr. Cooke is entitled to stand alone, as the gentleman to whom this country is indebted, for having practically introduced, and carried out, the electric telegraph as a useful undertaking, promising to be a work of national importance; and Prof. Wheatstone is acknowledged as the scientific man, whose profound and successful researches have already prepared the public to receive it as a project capable of practical application."

In regard to the rapid progress of the telegraph, it was the award of the above-named gentlemen, that to the united labors of the two gentlemen the credit was due.

Mr. Cooke had brought his inventions to England, and to effect success, he needed the scientific assistance of some gentleman, who could inspire the public with confidence in the telegraph, and he never ceased, until he had secured the invaluable co-operation of Prof. Wheatstone, and the two gentlemen embarked in the enterprise, upon agreed terms as to interest and duties, early in May, 1837.

THE SECONDARY CIRCUIT INVENTED.

During the month of April, 1837, Messrs. Cooke and Wheatstone united their labors, to perfect new improvements for the telegraph, and the first achievement was the discharger and

Fig. 17.

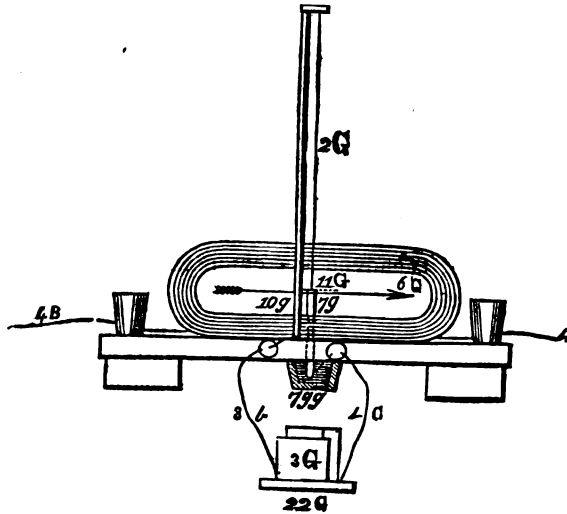
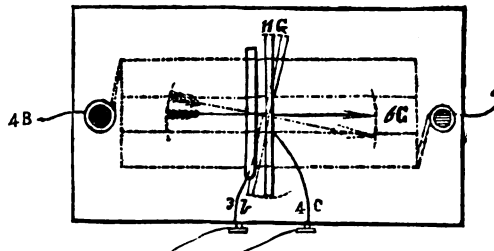

Fig. 18.



secondary circuit, represented by figs. 17 and 18; to be applied to Mr. Cooke's original alarm, which was subsequently superseded in practice by Mr. Cooke's alarm, described in the second English specification. The principle of this new improvement was the motion imparted to an electrometer needle by a distant battery, being made to complete the circuit of a second battery, which second battery, excited temporary magnetism in an electro-magnet, and by its attraction removed the detent of clock-work mechanism.

The part 2G is of the distant electrometer instrument forming the discharger; 3G is the secondary battery operating with the second circuit; 3b is the battery or circuit wire, terminating in the stop 10g, and the wire 4c, in the cross-piece 11g; so that, when the magnetic needle was moved by an

electric current, the cross-piece 11c was brought into connection with stop 10g; and completed the circuit of the secondary battery, 3g; 6g is the electrometer needle, carrying the cross-piece, 11c; 7g is a connecting and steadying platinum-piece immersed in 7gg, which is a mercury cup; 10g is a fixed stop, being the termination of battery wire 3b; 11c is the moveable cross-piece, here fixed on an axis of a magnetic needle. Fig. 17 is the side view of the apparatus, and fig. 18 is the top view, showing the movement of the needle.

MR. COOKE IMPROVES HIS ORIGINAL TELEGRAPH.

Fig. 19.

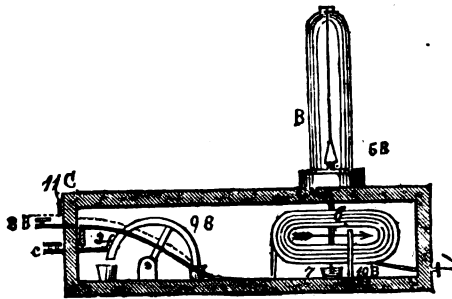

In the month of April, 1837, Mr. Cooke, while preparing his application for a patent, made some improvements on his electrometer telegraph of 1836. This new combination included the entire alarm attachment, as practically operated at the present

time. It contained the old signal apparatus, slightly varied, and the original cross-piece. It resembled, very much, his original invention, except in the addition of the alarm, which

Fig. 20.

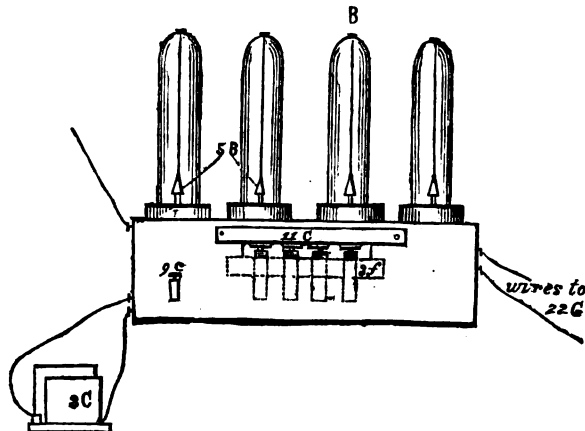

had been adopted in the mechanical instrument, in conjunction with the secondary circuit; this was an important improvement, and it was suggested by the permutating keys and the second mechanical telegraph. The principles of the two were adopted in the use of one common blank wire, which was in

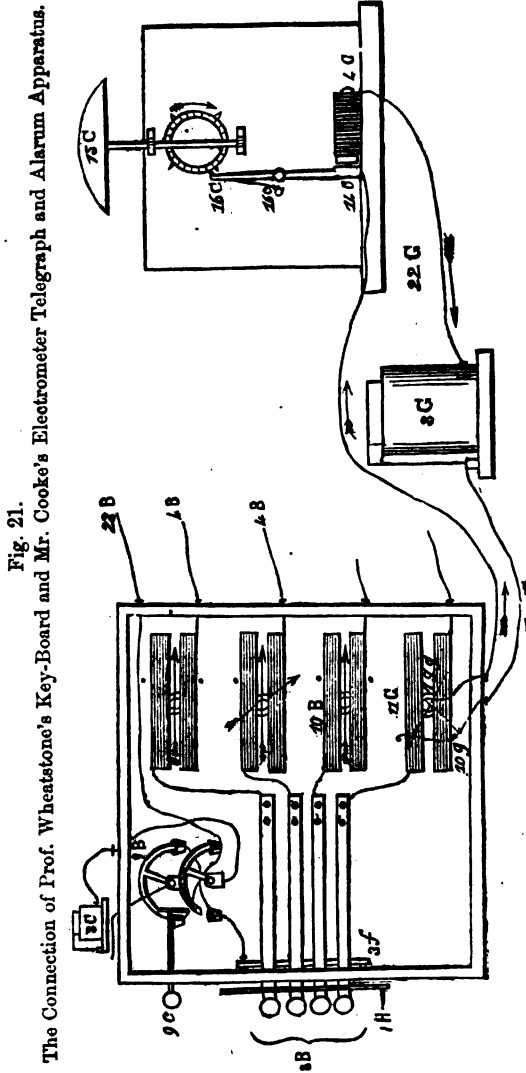

Fig. 21.
The Connection of Prof. Wheatstone's Key-Board and Mr. Cooke's Electrometer Telegraph and Alarm Apparatus.

permanent connection with both terminal batteries. By this combination the movements of single needles were effected, and a distinct class of signals was made, which, subsequently, was found to be highly valuable in practice. Figures 19, 20, and 21, give different views of this later improvement. It is founded upon the principle of the commutation of several electrometer wires with one blank or return wire. Signals given by the motion of one or more needles, were the same as those given in the original invention of 1836. Figure 19 represents a side view, showing the application of the key to the battery. When the key at 8b is pressed, the arc rod 3f is carried into the mercury cup or other contact arrangement closing the voltaic circuit. Fig. 20 is a front view of the same apparatus, the keys being shown by the dotted lines. Fig. 21 is the top view of figs. 19 and 20 having also the alarum attachment, herein before described. The whole of the mechanical appliances, embraced in this telegraphic organization, have now been described sufficiently to enable the reader to understand the success attained by Mr. Cooke in the invention.

ALL THE IMPROVEMENTS COMBINED.

I have now arrived at the most important invention, that is, the whole combination of improvements, made by Messrs. Cooke and Wheatstone, and for which a patent was obtained, dated June 12th, 1837. The fundamental principle of this telegraph was the same upon which was founded Mr. Cooke's original invention, with the addition of the vertical electrometers and astatic needles, and the invention of the converging vertical diagram, upon which the needles exhibited their relative positions in the formation of signals.

This arrangement contemplated the use of five wires of principal and secondary circuits. The second circuit was designed for alarum purposes.

Before proceeding in the further explanation of the principal circuit—which has already been done sufficient to give the reader an idea of its connection with the second circuit—I will describe the secondary circuit (fig. 22): G is the electrometer, the coils of which are in the main or principal circuit; the to and from wires of which are seen upon the left of the figure; 3b and 4h, are conductors, having at tops mercury cups, into which the fork on the end of the needle descends, whenever a current passes through the electrometer. The connection made between the mercury cups by the fork at the end of the needles, closes the second circuit, in which is placed the voltaic battery 3g; 14c is the electro-magnet, around which the local or

Fig. 22.

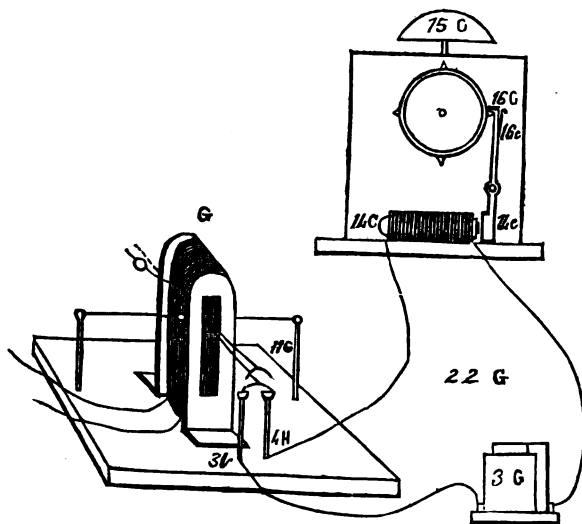

secondary circuit traverses, and magnetizes the soft iron cores or horse-shoe; 14c is the armature and detent rod attached, which catches upon the teeth of the wheel at 16c. When the armature is attracted, the wheel is let revolve, which causes a hammer to strike upon the bell 15c, producing an alarm of any required sound. In this manner, was practically operated a second circuit for the making of intelligible sounds, effected by the aid of a main and a local circuit, the latter being subservient to the will of the operator in the manipulation of the principal or main circuit.

The signal dials were vertical and diamond shaped. The dial was an improvement devised a short time before the application for the first patent. I have, in the foregoing, described all the parts of the telegraph invented and patented by Messrs. Cooke and Wheatstone, respectively, and jointly. With a view to give the reader a better understanding of the system, I herewith present a description, taken from a publication issued in London in 1839, as follows, viz.:

DESCRIPTION OF THE APPARATUSES.

This arrangement requires the service of five electrometers, in every respect constructed similarly to those hereinbefore described. Figure 23 is a representation of the dial, which is also a covering to the case containing, in the interior, the

five electrometers and their wires (shown at the opening in the dial board), and numbered, 1, 1; 2, 2; 3, 3; 4, 4, and 5, 5. The coils of the multipliers are secured with their needles to the case, having each exterior needle projecting beyond the dial, so as to be exposed to view. Of the wires from the coils, five are represented as passing out of the side of the case, on the left hand, and are numbered 1, 2, 3, 4, and 5. The other five wires pass out on the right hand, and are numbered in the same manner. The wires of the same number as the electrometer, are those which belong to it, and are continuous. Thus the wire 1, on the left hand, proceeds to the first coil of electrometer 1, then to the second coil, and then coming off,

Fig. 23.

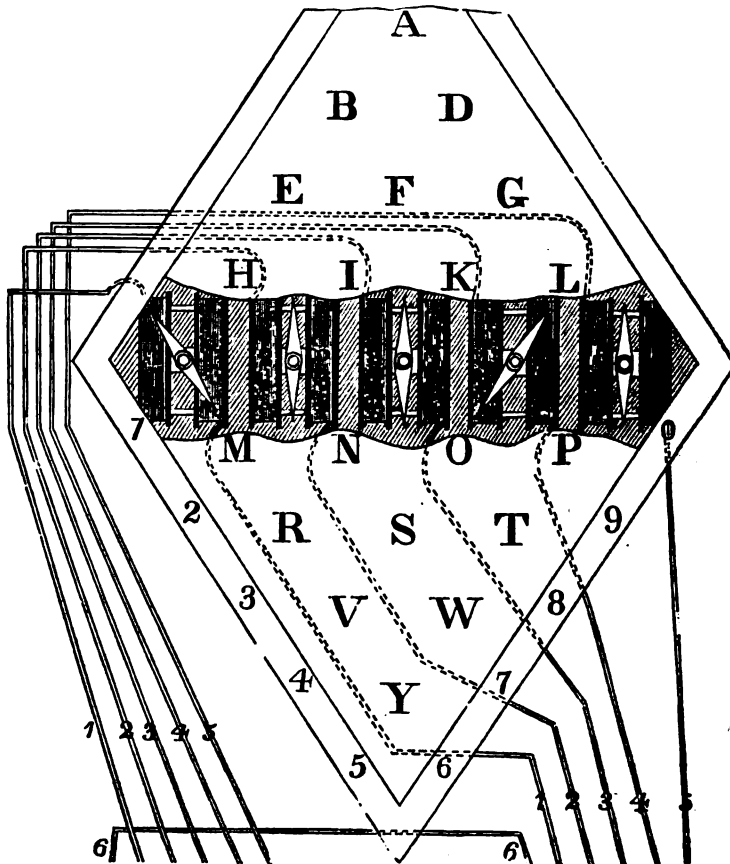

passes out of the case, and is numbered 1, on the right hand. So of the other wires, thus numbered. The dial has permanently marked upon it at proper distances and angles, twenty of the letters of the alphabet, viz. A, B, D, E, F, G, H, I, K, L, M, N, O, P, R, S, T, V, W, Y. On the margin of the lower half of the dial are marked the numerals, 1, 2, 3, 4, 5, 6, 7, 8, 9 and 0. The letters, c, j, q, u, x, z, are not represented on the dial, unless some six of those already there are made to sustain two characters each, of which the specification is silent. Each needle has two motions; one to the right, and the other to the left. For the designation of any of the *letters*, the deflection of two needles are required, but for the *numerals*, one needle only. The letter intended to be noted by the observer, is designated, in the operation of the telegraph, by the *joint deflection* of two needles, pointing by their convergence to the letter. For example, the needles, 1 and 4, cut each other, by the lines of their joint deflection, at the letter v, on the dial, which is the letter intended to be observed at the receiving station. In the same manner any other letter upon the dial may be selected for observation. Suppose the first needle to be vertical, as the needles 2, 3, and 5, then needle 4 being only deflected, points to the numeral 4, as the number designed.

I will now proceed to describe the arrangement of the springs and buttons upon the platform, c c, figure 24 (representing a

Fig. 24.

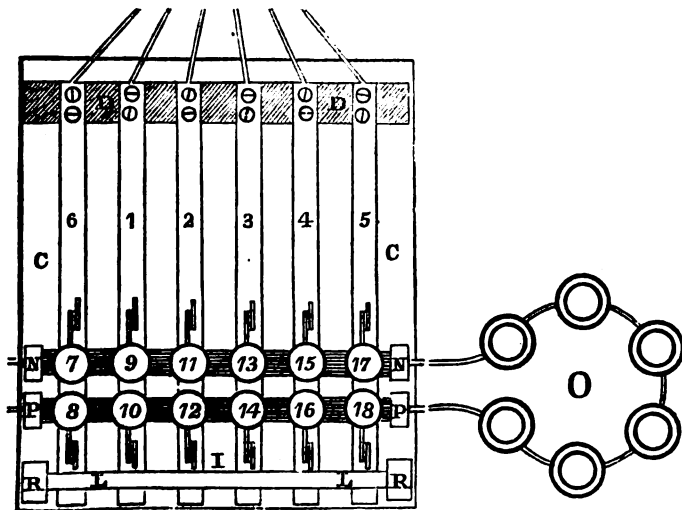

top view), by the operation of which, any two needles may be deflected to designate a letter, or one needle to designate a numeral.

The numbers, 6, 1, 2, 3, 4, and 5, represent keys of thin brass, and elastic, and are each fastened to a wooden support, *d, d*, by means of two screws. These keys are continued under and project beyond, the brass bar, *L* and *L*, which is supported by two standards, *r* and *r*. Whenever these keys are not pressed upon, they are each in *metallic contact* with the bar, *r* and *r*. The numbers 7, 8, 9, 10, &c., represent ivory buttons with a metallic stem beneath them, passing through a hole in the spring, or key, and on the lower side of the spring the stem is enlarged, so as to form a kind of hammer, designed to make a metallic contact with the two brass bars, beneath the springs, and represented as supported by the standards *n* and *n*, and *p* and *p*. Each of the buttons has a small wire spiral spring, to which it is fastened, and the small spring is itself fastened to the larger spring. *o* represents the voltaic battery, with its poles in connection with the two metallic bars, *n* and *p*.

Figure 25 represents a side view of the key arrangement; *F* is the platform; *E* the wooden support of the six keys; *H* is the larger spring, or key, secured to the support by screws, *h*; the spring is observed to project beyond the metallic cross bar, *L*, after passing beneath it; *r* is the support of the cross bar *L*; *n* and *o* are two of the ivory buttons, upon their spiral springs, *a* and *c*. Below the button, *o*, is a shoulder, formed at *i*, upon the stem which passes through the spring, *H*, and another shoulder is formed by the hammer, *u*, below the spring. It will be observed, that two buttons of the same key are never used at the same time. If the button, *o*, is to be

Fig. 25

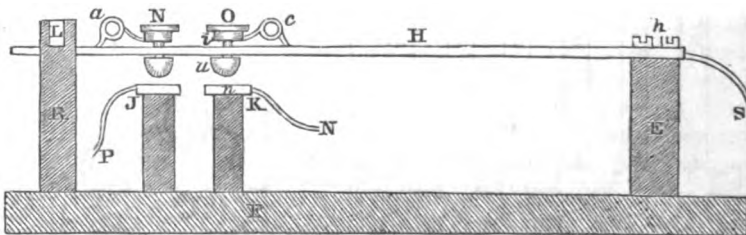

pressed down, the weaker spring, *c*, will permit it to descend until the upper shoulder comes in contact with the larger spring, *H*, when more pressure is applied, and that spring is

brought down, breaking its contact with the metallic cross-bar, *l*, until the hammer, *u*, comes in contact with the metallic plate, *n*, upon the support, *k*, and as the plate, *n*, is connected with the *n* pole of the battery, the connection is formed with it. It will, however, be noticed that the button, *n*, not being pressed upon, *will not* (though it descends with the larger spring) be brought in contact with the other plate upon the support, *j*, and connected with the positive pole of the battery. To the end of each spring, a wire, *s*, is soldered, the purpose of which will be shown hereafter.

Fig. 26.

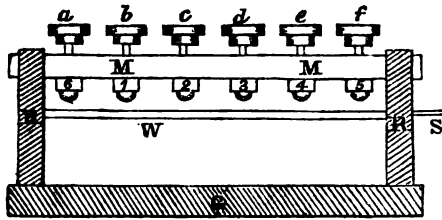

Figure 26 represents an end view of the key arrangement: *a, b, c, d, e, f*, are the buttons; *m* and *m* the metallic cross-bar, beneath which are seen the ends of the six larger springs, 6, 1, 2, 3, 4, and 5; *r* and *r* are the supports of the bar, *m* and *m*; *g* is the platform; *w* is the support of the metallic plates, with which the hammers of the little keys, or buttons, come in contact; *s* the wire leading to the battery.

Having shown the several parts, I will proceed to describe the arrangements of two termini, as prepared for transmitting intelligence. Figure 27 represents the arrangement of one station, which we may suppose to be PADDINGTON. Figure 28 represents the plan of the other station, which we will suppose to be SLOUGH. The distance between these two places is eighteen miles.

In figure 27, it will be seen, that a wire is soldered to the end of each of the springs 6, 1, 2, 3, 4, and 5, and respectively connected with the five wires of the dial, and the common communicating wire number 6, which does not pass through the dial, nor is connected with any of the electrometers. On the right hand side of the dial, the wires are extended until they are shown as broken. From this point to the opposite one, figure 28, where the wires appear also as interrupted, we may suppose 18 miles to intervene. The wires here proceed to the dial of the Slough station, making their proper connections

PADDINGTON.

Fig. 27.

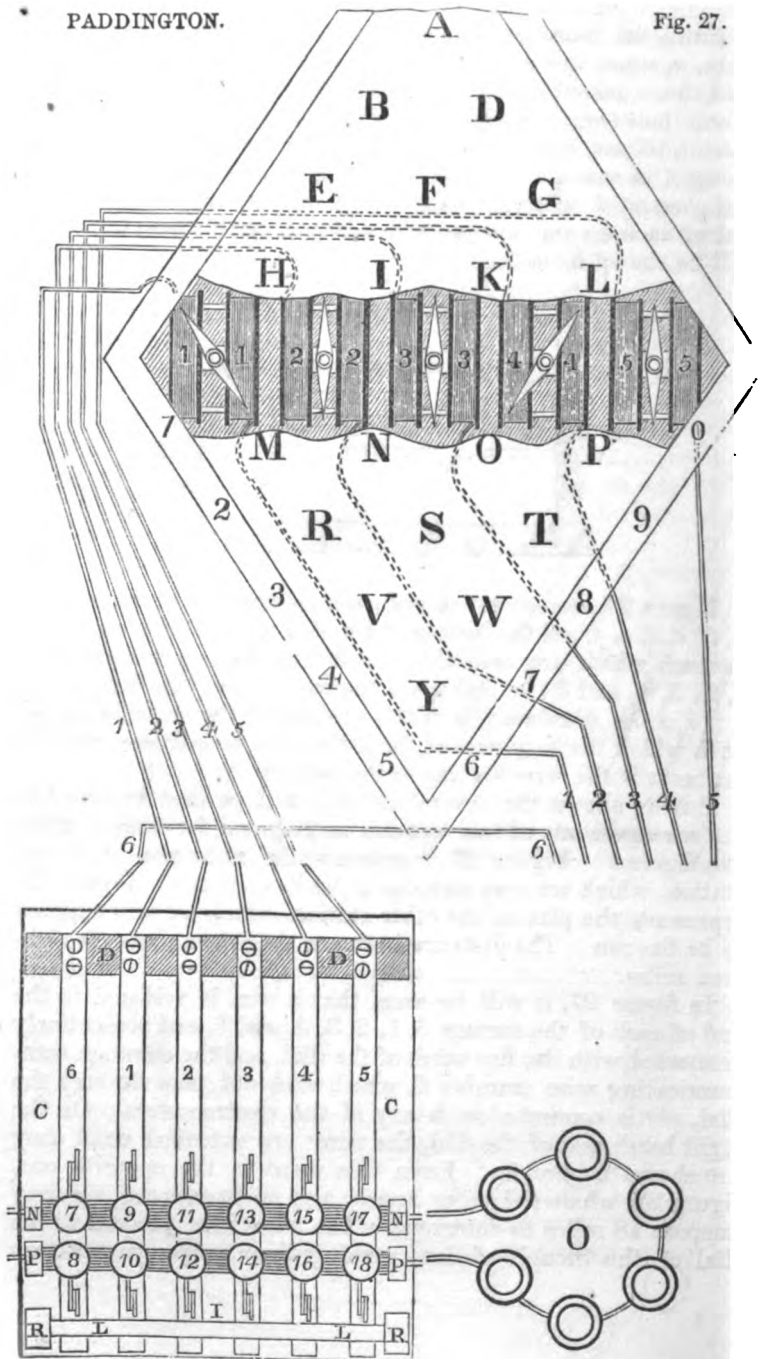

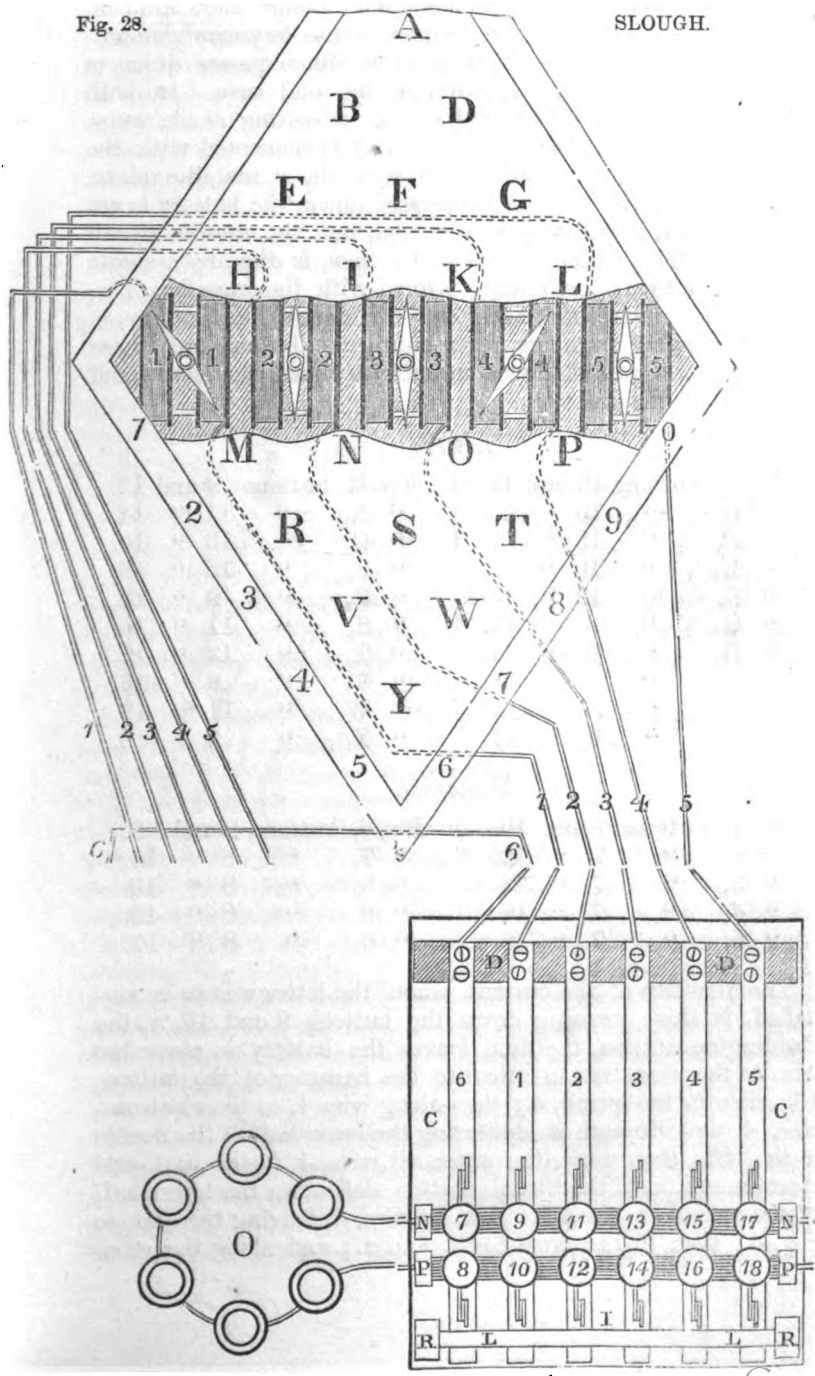

with their respective, electrometers, and thence they are continued and soldered to their springs of the key arrangement, with the exception of wire number 6, which passes direct to the key 6, without going through the dial case. In both figures, is represented the battery, o, consisting of six cups. The wire from one pole of the battery is connected with the n metallic plate, the other wire with the p metallic plate. While none of the buttons are pressed down, the battery is *not* in action, and it will also be observed, that the circuits are all *complete*. The action of the keys, then, is this, by a single operation to break the circuit formed with the cross-bar, L L, and, at the same time, bring *into* the circuit, the battery, o.

The following numbers, representing the buttons, are those necessary to be pressed down, in order to signal the letters and numerals on the dial :

Letters.

For A, buttons 10 and 17. " B, " 10 " 15. " D, " 12 " 17. " E, " 10 " 13. " F, " 12 " 15. " G, " 14 " 17. " H, " 10 " 11. " I, " 12 " 13. " K, " 14 " 15. " L, " 16 " 17.		For M, buttons 9 and 12. " N, " 11 " 14. " O, " 13 " 16. " P, " 15 " 18. " R, " 9 " 14. " S, " 11 " 16. " T, " 13 " 18. " V, " 9 " 16. " W, " 11 " 18. " Y, " 9 " 18.
--	--	--

Numerals.

For 1, buttons 7 and 10. " 2, " 7 " 12. " 3, " 7 " 14. " 4, " 7 " 16. " 5, " 7 " 18.		For 6, buttons 8 and 9. " 7, " 8 " 11. " 8, " 8 " 13. " 9, " 8 " 15. " 0, " 8 " 17.
--	--	---

The direction of the current, when the letter v is to be signalled, is this: pressing down the buttons, 9 and 16, at the Paddington station, the fluid leaves the battery, o, along the wire to the cross bar, p; then to the hammer of the button, 16; then to the spring, 4; then along wire 4, to the electrometer, 4, and through it, deflecting the lower half of the needle to the left; then along the extended wire, 4, to the dial, and electrometer, 4, of the Slough station, deflecting the lower half of that needle to the left; then to wire, 4, leaving the dial, to key, 4; then to the cross-bar, L and L; and along the cross

bar to key, 1; then to wire, 1; then to electrometer, 1; and through it, deflecting the lower half of the needle to the right; thence it proceeds along the extended wire, 1, to the Paddington station; entering the dial to the electrometer, 1, deflecting the lower half of the needle to the right; then along wire, 1, to the key, 1; then to button 9; then to the cross-bar, N, beneath; and then to the negative pole of the battery, o. It will be observed, that the needles of both stations, thus deflected, point to the same letter v.

If a numeral is be signaled, it is obvious, that but one electrometer is needed. We will, therefore, suppose that the needle, 1, is vertical.

Let the buttons, 7 and 16, be pressed down, at the Paddington station. The current then leaves the positive pole of the battery, o, to the cross-bar, P; then to the key, 4; then along wire, 4, to electrometer, 4, deflecting the lower half of the needle to the left; thence to the Slough station to electrometer, 4, deflecting the lower half of the needle to the left; then to wire, 4; then to key, 4; then to the cross-bar, L and L, and along it to key, 6; then to wire, 6, and along the extended wire to the Paddington station, to key, 6; then to the cross-bar beneath the button, 7; then to the negative pole of the battery, o. The needles, 4 and 4, of both stations, are simultaneously deflected, so as to point to the figure, 4, on the margin of the dial.

In this manner the circuits required for each letter and numeral may be traced out. Now, suppose the message to be sent from the Paddington station to the Slough station, is this, "WE HAVE MET THE ENEMY AND THEY ARE OURS." The operator at Paddington presses down the buttons, 11 and 18, for signaling upon the dial of the Slough station, the letter w. The operator there, and who is supposed to be constantly on the watch, observes the two needles pointing at w. He writes it down, or calls it out aloud, to another, who records it, taking, according to a calculation given in a recent account, two seconds at least, for each signal. Then the buttons, 10 and 13, are pressed down, and the needles are observed to point at e; and so for the remaining letters of the sentence, u excepted, which has no letter on the dial.

IMPROVEMENTS PATENTED IN 1838.

The second English patent was sealed 18th of April, 1838, for an improvement, with the power of communicating from intermediate points in either direction; but when not working, the alarum belonging to it could be sounded from either termi-

nus to demand attention. The patent embraced mile-post arrangements for the connection of portable telegraph, and for proving the wires. Spare wires were arranged, by means of which, faulty wires could be restored at several places without

Fig. 29.
A diagram of the apparatus, patented in 1838, for communicating both directions at an intermediate station.

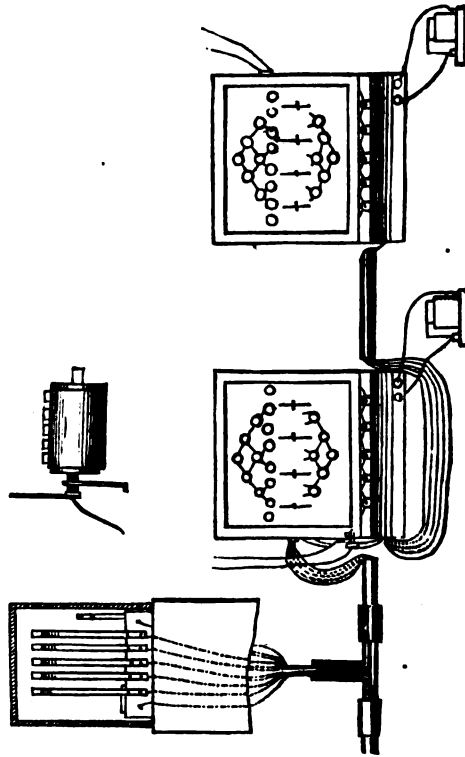

disturbing the general line. Iron tubing and fittings were specified, for the protection of the conducting wires, and admitting of their being carried under ground. Besides these, there were other valuable improvements invented by M. Cooke, having in view the perfection of his telegraphic system, not only in regard to the manipulating instruments of the station, but also relative to the mode of constructing the lines, and for maintaining a continuous means of electric communication.

At the date of this patent, but little was known in regard

to the difficulties to be encountered, and to avoid all kinds of hindrances, the telegrapher had to devise many ingenious contrivances.

WHEATSTONE'S MECHANICAL TELEGRAPH.

Fig. 30.

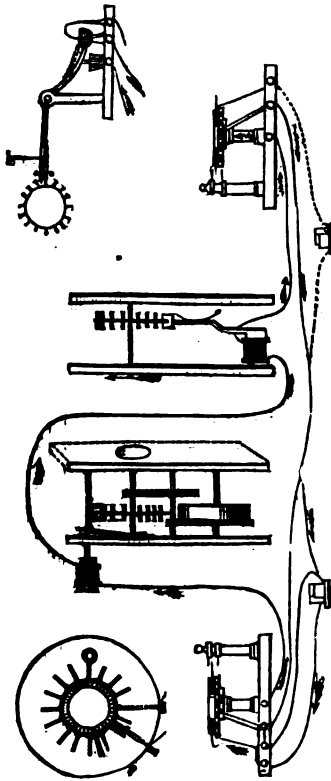

Wheatstone's mechanical telegraphic apparatus, invented in 1839, was considered an improvement on Cooke's mechanical telegraph, invented in 1836, though never put in general use.

The next important improvement was the mechanical telegraph, invented by Prof. Wheatstone, in the autumn of 1839. It was an escapement apparatus, with one magnet and two wires, founded upon the principle of giving signals by a revolving dial fixed on the arbor of an escapement wheel, which was moved by a maintaining power on the removing of an alternating escapement detent, by the alternate attractive force of a magnet, and the reaction of a spring. Also, moved by the alternate attractive force of a magnet and reaction of a spring, without maintaining power, adapted for domestic use. Also,

a capstan communicator, effecting by a revolving motion, the breaking and renewal of the current, corresponding with the alternating movement of the escapement. Also, an alarum detent, removed by the blow of a hammer transmitted to detent, when required, by a magnetic needle interposed by an electric current between the hammer and detent; and, also, the substitution of the magneto-electric machine for the voltaic battery. Such were the principles embraced in this patent. Fig. 30 is a skeleton view of the apparatus. Figures 31, 32, and 33, are more detailed representations of the ingenious device, and with a little study, the reader will fully comprehend the mechanism, and the application of the science to the art in the premises.

Fig. 31.

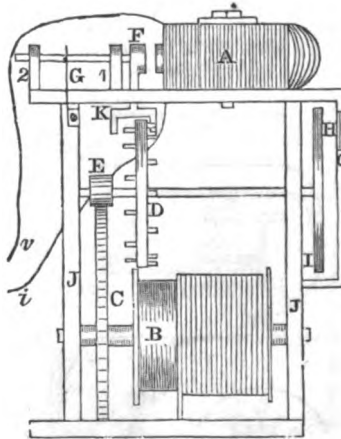
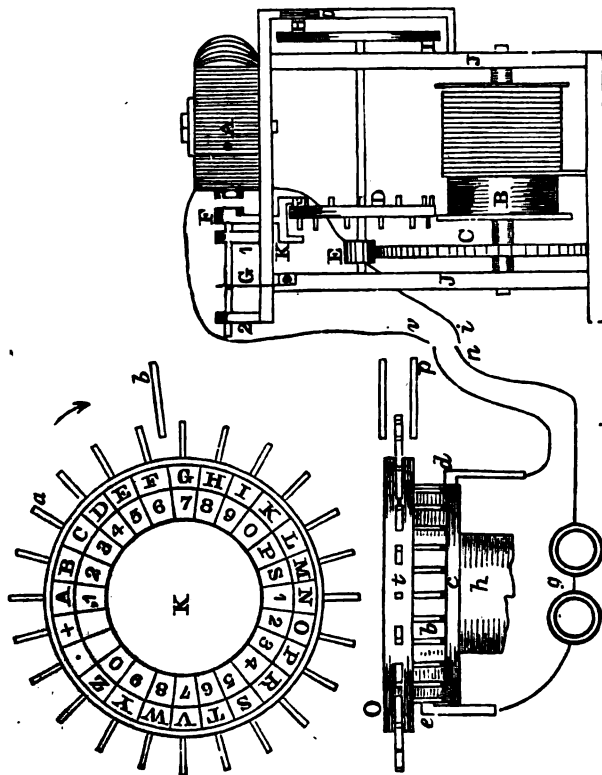

Figure 31, represents a side elevation of the dial and clock work of the *receiving station*. *A* represents an edge view of the electro magnet, from which proceed the two wires, *v* and *i*; *J* and *J* is the brass frame containing the wheel work, *C* and *E*; the pin wheel, *D*; the dial plate, *I*; and the barrel *B*, which is driven by a weight and cord. In the side of the wheel *D*, are pins projecting from the rim, parallel with the axis, and are equal in number to the divisions, or letters, upon the dial, *I*. They are, however, placed alternately on each side of the rim. *F* is the armature of the magnet, fastened upon a horizontal rod, sliding freely through the standards *1* and *2*. *G* represents a spring, fastened to the frame, *J*, and which carries back the armature, *F*, when the magnet has ceased to attract it. From the armature there extends downward an arm, *K*, which, as it

approaches the pin wheel, *d*, presents two arms, or pallets, one on each side of the wheel. These pallets are so arranged with regard to the pins, that if one pallet releases a pin on one side of the wheel, the same movement will cause the other pallet on the other side, to arrest the motion of the wheel by its striking against the next alternate pin. *h* and *i* is an edge view of the circular dial, enclosed in a case, with a single opening at *o*, so that only one letter at a time can be seen.

Figure 32, represents the two instruments: *o* the *transmitting* instrument, and the right hand figure the *receiving* instrument. The wires, *v* and *i*, are respectively connected with *p* and *n*. It will be observed, that the armature, *f*, is not attracted, and that the right hand pallet is checking the pin wheel, so that the dial is stationary. If, however, the disk, *t*, is turned so that the circuit is completed, by the contact of the spring, *e*, with one of the ribs, instantly the armature isat-

Fig. 32.



tracted by the electro-magnet, which will carry the right-hand pallet away from the pin wheel, and which will then move by the action of the weight upon the barrel *b*, until it is checked by the left-hand pallet, which had advanced to the wheel at the same time the other receded. This single operation has moved the disk one division, and the armature is still attracted. Now let the disk, *o*, be turned until the spring, *e*, has been passed by the rib, and is in contact with the ivory only, instantly the current ceases; the armature, *F*, recedes from the magnet by the action of the spring, *g*; this has taken the left-hand pallet from the pin wheel, which is permitted to move until the next pin strikes against the right-hand pallet. This has now

Fig. 33.

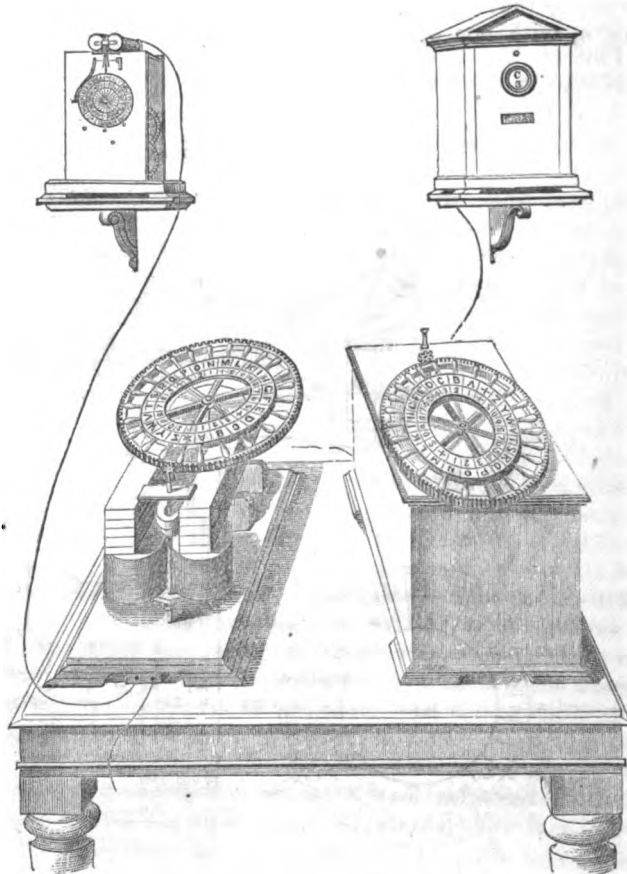

brought another letter in front of the aperture at *H*. Thus it will be seen, that the design of this instrument is to bring into view, at the aperture such letters as are required in transmitting a message.

Suppose letter *A* is at the point, *b*, of the *disk*; and letter *A* of the *dial* is opposite the opening; the instrument is now ready to transmit, and let the letter *i*, be the first of the message. The operator gently turns the disk round in the direction of the arrow, so that each time the circuit is broken, a new letter appears at the dial, and each time it is closed by the operation of the pallets, in checking and releasing the pin wheel. This is the operation until the letter *i*, has reached the point, *b*, when a short pause is made.

Figure 33 represents the instrument in its case, and also as exposed. The permanent and electro-magnets are seen in the left-hand figure. When the disk was revolved, a current of electricity was generated, and the effect was produced at the distant station as herein before described.

FURTHER IMPROVEMENTS BY MR. COOKE.

The next and last improvement, was that invented by Mr. Cooke, in the month of November, 1839.

Figures 34, 35, and 36, represent the escapement telegraph, with three wires, as invented by Mr. Cooke. The three figures are of the same arrangement, and the wires 4*B* in each figure are intended to unite.

The principles on which this invention was founded were, viz. :

1st. Giving signals on a fixed dial by a revolving index-hand, fixed on the arbor of an escapement-wheel, moved by a maintaining power, on being stopped by the retentive attraction of one of the two electro-magnets, acting upon the alternating escapement detent.

2d. Portable telegraph, requiring no battery to be carried with it, and adapted for working in both directions at the same time.

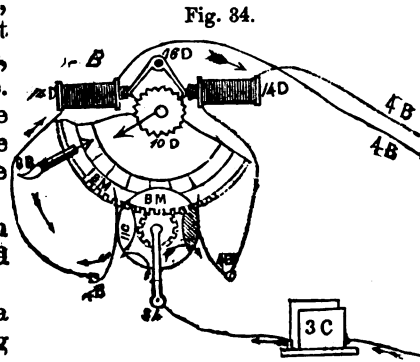
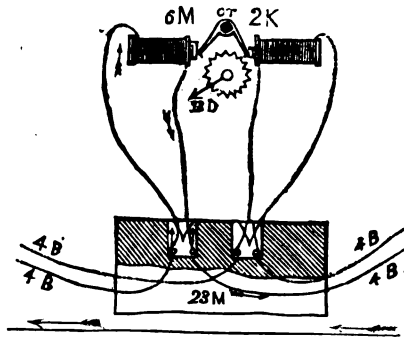

Fig. 85.



3d. The application of a constant current of electricity for telegraphing.

4th. Self-acting telegraph, the hand being fixed to the arbor of the escapement; adapted for tunnels, crossings, and approaches to stations: enabling a train to give notice of its own approach in any direction; also, adapted to give more signals when required, by a hand fixed on a second wheel.

Fig. 86.

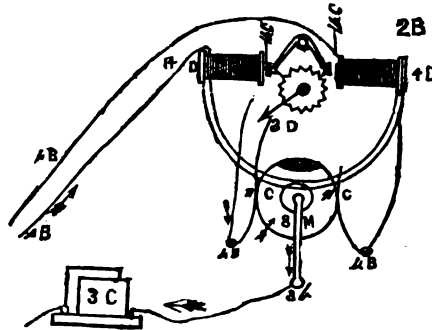

5th. Air pressure apparatus, for keeping the inner surface of the tube under constant pressure, and, by adapting the degree of pressure to circumstances, enabling the tube to be carried safely under water. A barometrical detector will indicate, even during dry weather, any unsoundness of the tubing, which hitherto has been indicated only by the interruption of the signals caused by the admission of wet. A portable detector can be applied, at each providing box. The air pressure apparatus may, also, be used for forcing dry air through the tube, to remove any dampness that might exist.

In figures 34, B M, and 36, 8M, are the connecting wheels of the communicator, by which the telegraph wires are brought into connection with the pole bar 3; the batteries are 3c; 11c are self-acting cross-pieces, and the same pieces of metal, as B M, and 8M; 18M, in fig. 34, is a revolving communicator, concentric with the signals, and fulfilling all the conditions, whether applied to terminal, intermediate, or portable telegraphs, and capable of working the portable without a distinct battery; 14D, are the electro-magnets; 10D, 13D, 3D, are the index hands, and 4B, the conducting wires between the respective stations.

The different telegraphs, and parts thereof, were, from time to time improved, and to this day, the ingenious mechanic is devoting his mind toward the perfection of the general combination. Notwithstanding the instruments have undergone some change in their peculiar construction, yet, in principle, they remain the same, and perhaps ever will. Mr. Cooke can enter the operating room, and there find his Heidelberg apparatus, though dressed in fine rosewood or mahogany. The plain and simple mantle he placed upon it has been laid aside, and the mechanic has ornamented it with beautiful tessellated work. The original electrometer telegraph will be found within its decorated casing, and perhaps will for all time, conferring honor and well-earned fame upon the inventor. The annals of England are studded with the names of men who have performed deeds great upon the battle-field, of those who have, by their pen, given to the world light and knowledge, to illumine the pathway of men through life; but the crowning glory is due to William Fothergill Cooke, who has, by the invention of the English telegraph, added to his nation's renown increased lustre, and to the galaxy of her illustrious men, the most brilliant star.

THE ENGLISH ELECTRIC TELEGRAPH

CHAPTER XIV.

English Telegraph, and Description of its Electrometer—The Single-Needle Apparatus—Formation of the Alphabet—Single-Needle Instrument and Voltaic Circuit—The Double-Needle Instrument, Alphabet, and Manipulation—The Alarm Apparatus—Combining and Arranging of Circuits.

ENGLISH TELEGRAPH AND DESCRIPTION OF ITS ELECTROMETER.

IN preceding parts of this work, I have, with much detail, described the early history of the English Needle Telegraphs, and the principles of philosophy upon which they were respectively founded. I now propose to explain to the reader the organization of the instruments, and the mode of manipulating them as practically operated at the present time.

In America, there has not been a just appreciation of the needle telegraph, nor even a moderate idea of the facility and certainty of its operation. In a minority opinion rendered in the Supreme Court of the United States of America, in 1854, it was said that the needle telegraph was an "inefficient contrivance." At that time, I cordially concurred in the opinion of the able jurist; but since then, I have witnessed the operation of the different systems of Europe, and my impressions have undergone some change. In the needle telegraph, the needle vibrates to the right or to the left, and the beats thus made have to be seen, in order to understand the message transmitted.

The American telegraph produces a sound. In many of the offices, the recording apparatus has been abandoned. It is a question yet to be determined in practical telegraphing, which is the most reliable, the sense of *seeing* or that of *hearing*.

In order that the reader may the better understand the subject matter herein considered, I will re-explain the structure of the electrometer, which is the vital part of the telegraph.

The coils *ik* of the electrometer, fig. 1, are composed of fine copper wire, insulated with silk. The wire is the same as

ordinarily used on the relay magnets of the American telegraphs. *h* is the exterior needle, made as the ordinary compass needle. The interior needle in the figure is the same, and their positions of rest are perpendicular, fastened to a common axis. The needles are brought to a vertical position, by placing on the lower end of the interior needle a weight, or the lower end is made the heaviest. When the voltaic current traverses the coils *i k*, the needles move from a perpendicular

Fig. 1.

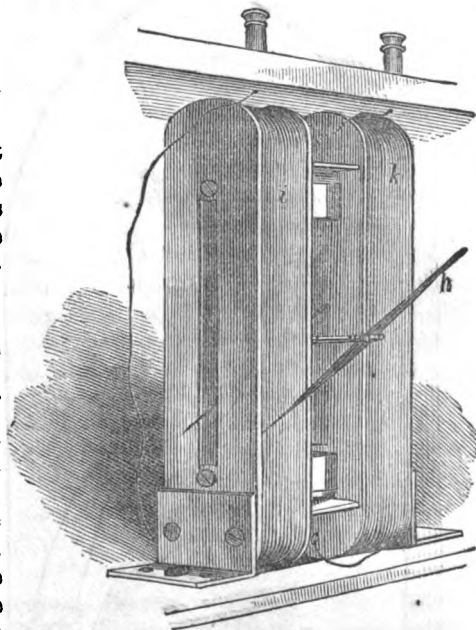
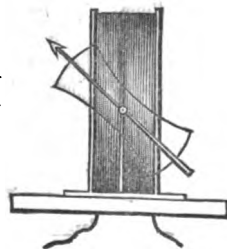

fig. 1. Two coils are adopted for convenience in the suspension of the axis bearing the needles. By the transmission of the voltaic current through the coils, the communication is made known by the deflection of the needles. Suppose the current is sent through the coil *i*, from the top to the bottom, or, in other words, from *i* downward, and in the other coil upward to *k*, the needle *h* will be deflected to the right, as seen in fig. 1. If the current be of great intensity, the needle will advance to a horizontal. When the current is sent upward to *i*, and downward from *k*, the needle will be deflected the reverse of the position given in fig. 1. The process of reversing the current is in the act of sending, as will be presently described.

Fig. 2.



The electrometer needles, represented by fig. 1, are not of the ordinary form adopted for the telegraph instruments. Fig. 2 shows the construction of the interior needle arrangement as sometimes employed. The exterior arrow needle has been thus placed in the figure to show the

north and south ends, the arrow head being the former. The interior needle is made larger, so as to retain a greater amount of magnetic force, and to be more sensitive when the electric influence pervades the coils. The exterior needle is sometimes made of wood, or of some light substance; its movement being caused by the deflection of the interior magnetized needle, it has been found most effective, when made of some light material.

Fig. 3.

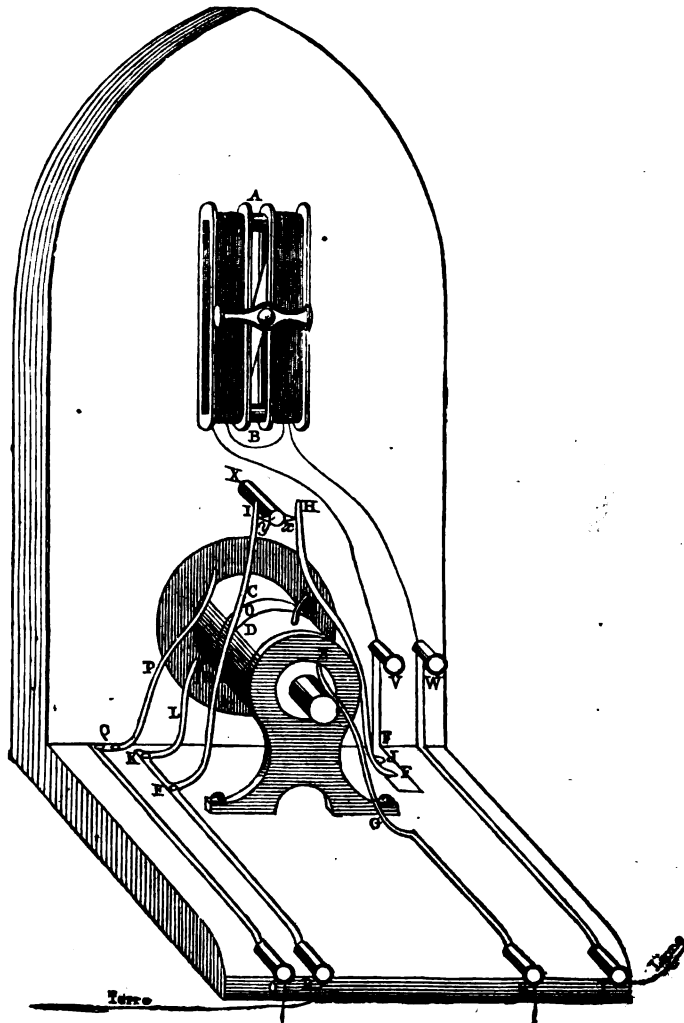

DESCRIPTION OF THE SINGLE-NEEDLE APPARATUS.

Having described the electrometer, I now propose to explain its application and its operation in its subserviency to mechanism for telegraphing. The electrometer *a b*, in fig. 3, is a rear view, as will be seen on comparing it with the angular view of fig. 1, and the front view in fig. 2. The cross-bar between *a* and *b* is attached to the frame work. To this cross-bar, made of wood or metal, is attached the moveable axis, to

Fig. 4.

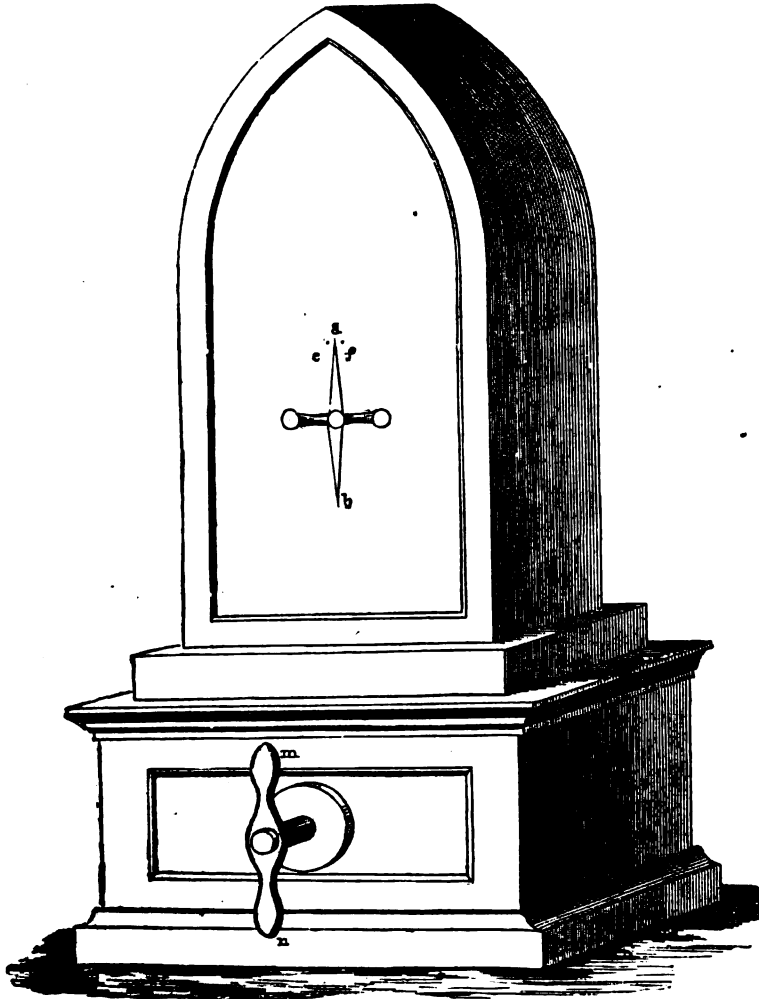

which is fastened the magnetic-needle in the middle of the coils, and the index needle in front of the coils. Between the coils and the index needle is the index face of the instrument. This face hides the mechanism, as seen by fig. 4. Fig. 3 is an open back view of a single needle instrument, and fig. 4 is the front view of the same, with the index needle *a b* in front of the face, through which traverses the axis upon which the needles are fastened.

The instruments vary in size from 10 inches to 20 inches high, and from 6 to 12 inches wide, shaped as the old mantel clock. I will now describe the manipulation of the single needle instrument, figs. 3 and 4.

The cylinder is divided into three parts, of which two, *c* and *d*, are copper, the third, *o*, is ivory, and this ivory section insulates *c* from *d*. Two copper points, *m n*, are fixed upon the cylinder, *m*, to the copper division, *d*, and *n*, to the copper, *c*; the former above and the latter below on the cylinder. These points communicate with the two poles of the battery by means of the springs *q p* and *g z*, which press, one upon the cylinder, and the other upon the gudgeon and the two metallic strips, *q q* and *g s*.

On each side of the cylinder are four springs, connected two and two by the strips *k e r*, and *f j f*. Two of these springs placed in front of *n*, in the ordinary condition, are generally pressing upon the two metallic points, *x y*, fixed at the extremity of a little horizontal copper cylinder, *x*. The two other springs are in front of *n*. They are shorter than the preceding strips, and one of them only, *k l*, is visible in the figure.

The earth wire is attached at *r*, and connects with the two springs, *k l* and *e i*. The line wire is attached at *t*, and communicates, by means of the electrometer, *a b*, and the strip, *f j f*, with the two other springs.

In the receiving position the exterior handle, *m n*, is vertical, as seen in fig. 4. The two points, *m n*, are also vertical, and do not touch the springs. The current coming from the line at *t*, after having traversed the electrometer, *a b*, passes over the spring, *f n*, and arrives at *r* by the two points, *x y*, and the two springs, *e i*. The needle, *a b*, fig. 4, deviates, and by the number and direction of its oscillations indicates the signals transmitted by the corresponding station.

In order to send the current by the zinc pole of the battery, the upper part of the handle, *m n*, is turned toward the left. The point, *m*, presses against the spring, *f n*, and separates it from *x*, and the point, *n*, presses against the spring, *k l*. The

copper pole is then in connection with the earth by means of the springs, *k l* and *q p*, the metallic piece *c*, the cylinder and the strip, *r k*, and *q q*. The zinc pole, which connects with the point, *n*, connects with the line by the spring, *n f*, the strip *f f v*, the wire of the electrometer and the strip. *w t*.

Turning the handle in the opposite direction, the point, *m*, separates the spring, *e i*, from *y*, the point, *n*, presses the spring, the foot of which is at *j*; the zinc pole is then in connection with the earth and the copper pole with the line. When the current traverses the electrometer, the inclination of the needle is always the same as that of the handle.

Sometimes an electro-magnet is substituted for the electrometer, as represented in the description of the magnetic telegraph apparatus.

In order to prevent the needle from swinging too far to the right or to the left, small pegs are placed on the face of the instrument, as seen in fig. 4, *e* and *f*, on the sides of the needle.

FORMATION OF THE ALPHABET.

The alphabet is formed of a combination of beats to the right and to the left. I have already mentioned that the deflection of the needle is changed from the right to the left, and *vice versa*, by transmitting the current from the respective poles of the battery. When it is desired to make the letter *A*,

Fig. 5.

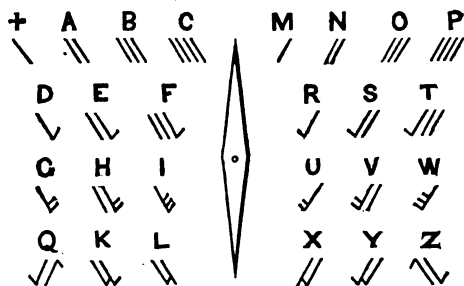

the needle is deflected to the left twice, the letter *c* four times, and for the letter *p*, four times to the right. For the letter *d*, first to the right and then to the left; for the letter *r*, first to the left and then to the right. The second beat is represented by the long arm of the angle, because if they were equal, the first beat could not be distinguished from the second. When the beat is seen they are of the same force, and the long and short arms are adopted for the book or for writing. In making the letters *q* and *z*, the short arms are also indicated first. Each

of these letters are composed of two deflections each way, thus, $v \wedge$, for q , and $\wedge v$, for z . These are the only letters requiring such a combination, and when they are formed, the rule determines which arms are to be short and which long. When figures are to be made, they are preceded by an arbitrary sign. Besides these signals there are compound signals, indicating *wait, go on, I understand, I do not understand, repeat, &c., &c.*

Fig. 6.

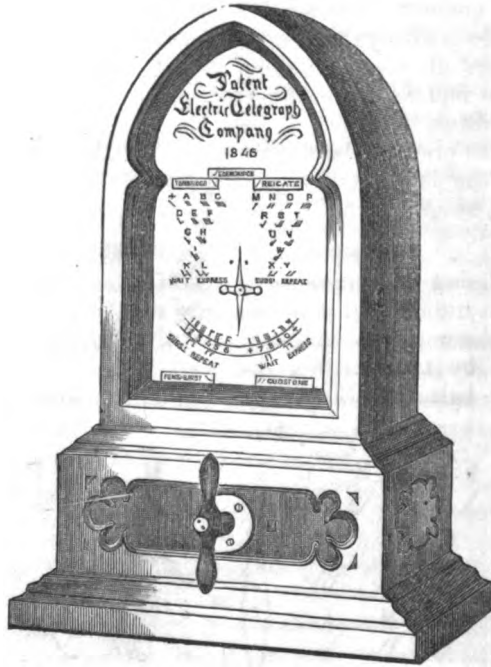

THE SINGLE-NEEDLE INSTRUMENT AND VOLTAIC CIRCUIT.

Fig. 6 is a representation of the single-needle instrument, as now employed in the offices in England. The alphabet upon its face, however, is not on the common instruments, except a few for students. It is the same as fig. 3, except a little more ornamental.

Fig. 7 is a representation of the interior of fig. 6, and the same as represented by fig. 3, and hereinbefore described, with the addition, however, of a voltaic battery and the course of the electric current. I have preferred to describe fig. 3, first, separate from the battery, to prevent confusion; and now that

the mechanism of the instrument has been considered, I will repeat, in part, and extend that description to the operation in connection with the voltaic battery.

The bobbins or coils *A*, are made of very fine insulated copper wire, in size about $\frac{1}{16}$ of an inch in diameter, or about No. 36, American gauge. These coils are from two to three inches long, in the form as seen by the different figures. The interior needle is in the rhomboid form, one and an eighth inch long and seven eighths of an inch broad. Sometimes several magnetized short needles are substituted for the one, all firmly secured on either or both sides of a thin ivory disk. The index or exterior needle, seen in fig. 6, is about three inches long. The frame of the coils *A* is made of copper, wood, ivory, or of any other material.

Fig. 7.

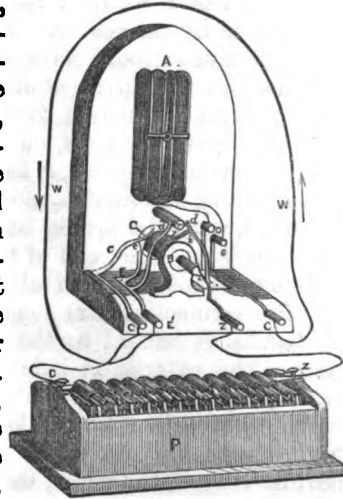

This frame is screwed to a plate of copper, on the sides of the telegraph instrument. The wires surrounding the right hand bobbin or coil is fastened to the screw *c*, as seen in fig. 7, which, by means of a metallic strap, is connected with the *c* on the right of the figure, secured on the base of the apparatus. The other end of the wire, on the left hand bobbin or coil, is in contact with another screw, *d*, supported by a strip of brass, which is fixed to the base; from this brass plate there rises an upright stiff steel spring *d*, which presses strongly against a point attached to an insulated brass rod *r*, screwed against the side of the case; on the opposite side of this rod is another point, against which a second steel spring *d* presses, and this spring is attached to a brass plate *E*, terminated by the binding-screw *E'*; this binding-screw *E'* is the terminal of the wire from the left hand coil. If *c* on the right, and *E'* on the left, be connected by a wire, *w*, the current will flow from *c*, on the right of the figure, through *g*, into the right-hand coil, out from the left-hand coil to *d*, thence through *d r d* to *E*, and to the terminal screw *E'*, and around the wire circuit *w w*, back to *c* on the right of the figure. The battery contact is broken, and the direction of the current reversed, by the action of the spring *d d*, in the following manner :

In fig. 7, *B* is a box-drum, moveable by a handle *H*, seen at the base of fig. 6; around either end of this drum are fixed the brass strips, as described in fig. 3. The lettering in figs. 6 and 7 are not the same for the identical parts of the like figures, but the parts in each are fully lettered, so that they may be respectively traced by the reader. In order that the mechanism may be better understood, I have described that of fig. 3, which will serve for the same parts of fig. 7.

On moving the drum, by turning the handle *H*, fig. 4, or in fig. 6, the steel spring *d*, on the right, in fig. 7, will be raised from its connecting point, *r*, the circuit will thus be broken; but by continuing the motion, *c*, on the left of the figure, will come in contact with the spring below it, and thus there will be a battery-pole at either end of the drum, and signals will thus be made on the dial, and on all the instruments connected with it. The connections are made in such a manner, that when the handle is turned to the right, the needle moves to the right. The exterior or index needle is always placed with its north pole downward, so that, in accordance with the law established by *Cersted*, of Copenhagen, looking at the face of the instrument, if the upper part of the needle is seen to be moving toward the right, the spectator may be sure that the current is ascending in that half of the wire which is nearest to him.

DOUBLE-NEEDLE INSTRUMENT—ITS ALPHABET AND MANIPULATION.

I have now with sufficient detail explained the action of the single-needle telegraph. I will next proceed to describe the double-needle instrument, which is, in fact, a union of two single-needle instruments, with some modification of the mechanism, as will be seen in fig. 8, which is a rear view of the apparatus. Fig. 9 is a front view of the same instrument. Fig. 10 is also a front view of a double-needle apparatus, but without the bell attachment.

Fig. 8 embraces the voltaic battery, the interior of the indicating apparatus, and the alarum attachment. Fig. 9, *B*, is the front view of the instrument, and *A* the alarum.

This instrument is in use on nearly all the railway lines in Great Britain, and in the service of the Electric Telegraph Company. Fig. 10 is the front view of a double-needle case, and the dotted lines of the left handle and the left index needle show the extent of the relative motions, in reversed order.

The alarum at *A*, fig. 9, is worked by the crank at *B*. The handles, *H* *H'*, are the manipulating keys that operate the needles, and *s* is the silent apparatus. In forming the letters of

the double needle apparatus, they are ranged from left to right, as in the ordinary mode of writing, in several lines above and below the points of the needles, the first series, from A to P

Fig. 8.

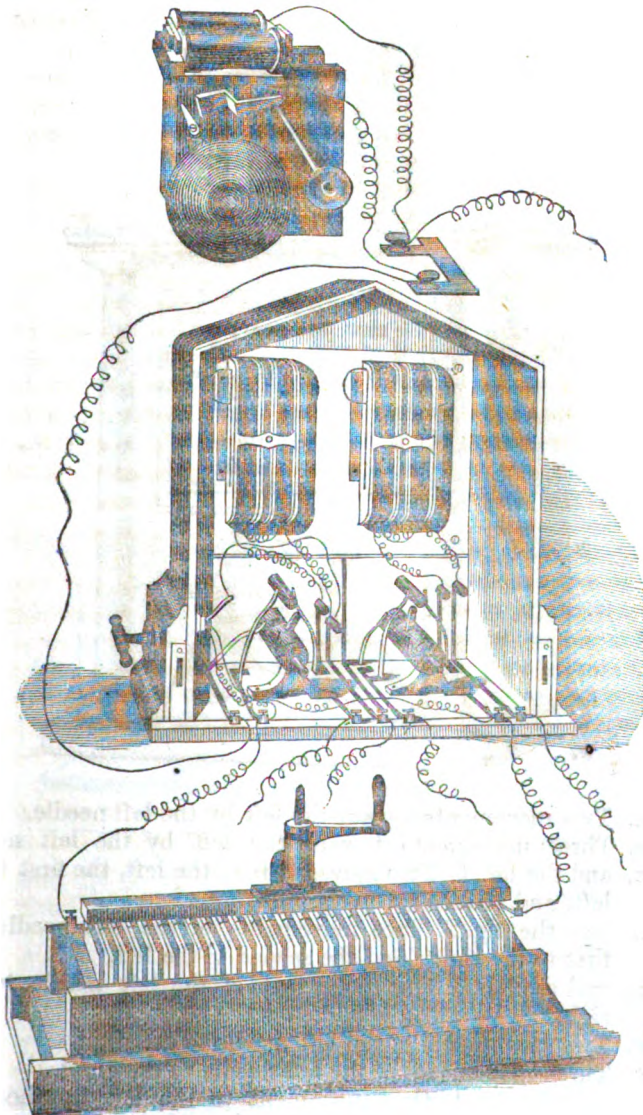

being above, and the second series, from R to Y, below. Each letter is made by one, two, or three movements, in the following order, viz.:

Fig. 9.

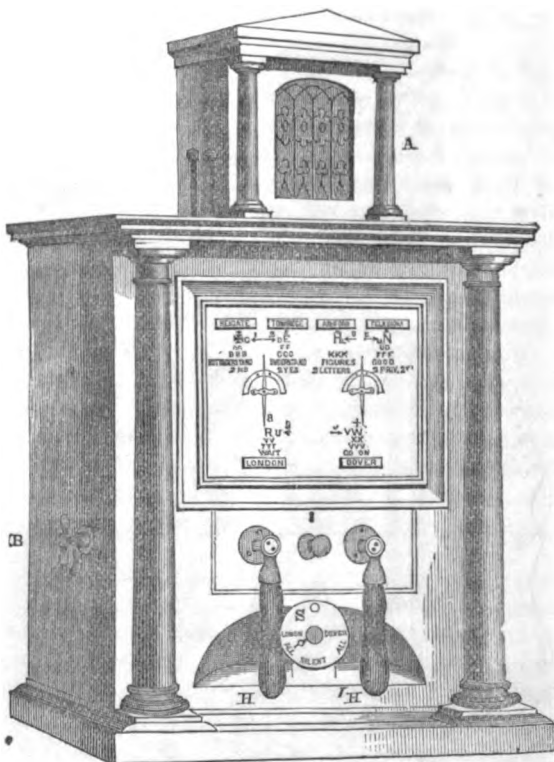

- A. Two movements toward the left by the left needle.
- B. Three movements toward the left by the left needle.
- C, and the fig. 1. Two movements of the left, the first to the left, and the second to the right.
- D, and the fig. 2. Two movements of the left needle, the first to the right, and the second to the left.
- E, and the fig. 3. One movement of the left needle to the right.
- F. Two movements of the left needle to the right.
- G. Three movements of the left needle to the right.
- H, and the fig. 4. One movement to the left by the right hand needle.

- l.** Two movements to the left by the right needle.
- j.** Is omitted, and replaced by g.
- k.** Three movements of the right needle to the left.

Fig. 10.

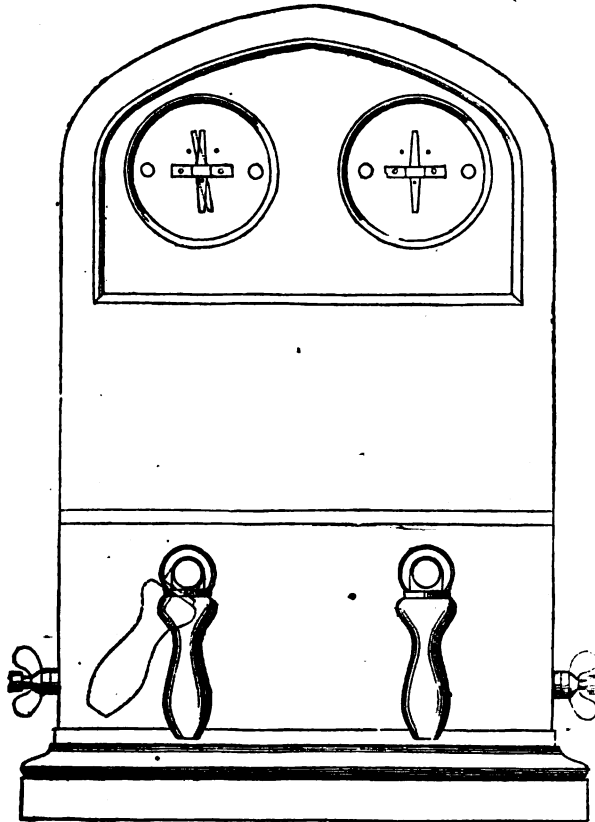

- l,** and the fig. 5. Two movements of the right-hand needle, the first to the right, the second to the left.
- m,** and the fig. 6. Two movements of the right needle, the first to the left, the second to the right.
- n,** and the fig. 7. One movement of the right needle toward the right.
- o.** Two movements of the right needle to the right.
- p.** Three movements of the right needle to the right.
- q.** Is omitted, and **k** substituted for it.

- r, and the fig. 8. A single movement of both needles toward the left.
- s. Two movements of both needles toward the right.
- t. Three movements of both needles toward the left.
- u, and the fig. 9. Two movements of both needles, the first to the right, the second to the left.
- v, and o. Two movements of both needles, the first to the left, the second to the right.
- w. One movement of both needles toward the right.
- x. Two movements of both needles toward the right.
- y. Three movements of both needles toward the right.
- z. Is omitted and replaced by s.

The above alphabet is only one of the different combinations in the English telegraph.

The sign of the cross, †, indicates the termination of a word, and is designated by a single movement of the left needle toward the left; the same signal is given when the receiving operator does not understand his correspondent's message.

The letter e is the signal for "yes" and "understand."

The signal e, however, is repeated twice, that is, two movements of the left needle toward the right.

The words "wait," "go on," seen on the right and left side of the bottom of the dial face, are of much importance in the transmission of messages. Suppose London wishes to correspond with Dover. The operator sends signal indicating Dover as the office desired. If the operator at Dover is engaged, and cannot receive the message from London, he sends the letters r r, which means "wait." When he is ready to receive the dispatch from London, he sends the letters w w, which indicate the arbitrary term, "go on." The correspondence then proceeds. Suppose London wishes to send a message to Tonbridge, Ryegate, Ashford, or any other office. The arbitrary signal indicating each station, is made; thus, for London the letter r is the signal, for Tonbridge, the letter e, for Dover, w, and so on. London signals Tonbridge, and the alarm attachment being in circuit, the bell is sounded, which calls the attention of the operator, who immediately repairs to his instruments, and reads the signal calls being made by London, the operator at Tonbridge responds by sending the signals r and e, which means that he is present, and the signal, "go on," is also sent if he is ready to receive the message. London then proceeds, first by ringing the bell, and then in the sending of the words by signaling each letter. If Tonbridge does not understand he sends the signal of the cross, †, and if he understands, he sends the signal e. When the message

is finished, London deflects his left hand needle twice to the left. Tunbridge returns the signal as a finish.

The numerals are indicated by the formation of the letters, preceded by the signals H and the cross, †. These signals mean that figures are to be sent, and not letters. These figures are given by the deflections representing the letters c, d, E, H, L, M, N, R, U and v. The w is used as a space mark between the figures, thus, for \$123 00 is sent c d E w v v. The dollar, sterling, franc, shilling, penny, and other terms, have arbitrary signals.

DESCRIPTION OF THE ALARUM APPARATUS.

The mechanism of the alarum apparatus is arranged at the upper part of the instrument. They are all based upon the same principles in science and art, but some differ immaterially from others in mechanism.

Fig. 11 represents the mechanism of the alarum. *a* is the electro magnet. *b* is the armature of soft iron, susceptible of attraction whenever the electric current traverses the coils or bobbins *a*. The armature is prevented from coming in contact with the electro-magnets by stop pins of copper, insulated with ivory, inserted in its face. The armature is mounted on the lever arm, *c*, which carries at its lower end a short projecting piece, *e*, which, catching in a stop on the circumference of the wheel, *d*, prevents it from moving. When the current ceases to traverse the helices or coils, the armature is drawn back to its normal position by the small spring, *f*. The principal pieces of the clock-work are shown in the figure, namely the cog-wheel, *b*, is connected by a pinion with the cog-wheel, *a*, which works *i*, and this again gives motion to *d*, which carries the stop. The anchor escapement, *g*, works on the wheel, *i*, and on the axis of the same wheel is placed the double-headed hammer, *h*. On completing the battery circuit, the armature, *b*, is attracted by the electro magnet, the long arm of the lever, *c*, moves to the left, and the wheel, *d*, being then set at liberty, the mainspring in the barrel, or the weight suspended therefrom, which is kept constantly wound up, sets it in motion, and

Fig. 11.

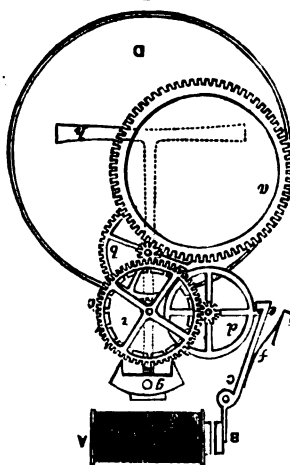

the hammer is instantly put into rapid vibration, striking alternately the opposite sides of the bell, *b*; the ringing is kept up as long as the circuit is closed, but the moment it is broken, the armature is detached by the spring, *f*, and the catch is again pressed into its place on the wheel, *d*. It is not the voltaic current that rings the bell, but the mainspring in the barrel, or the weight thereto attached. All that the electric current does is to disengage the catch. Any size bell can be rung by an arrangement of this kind. This is verified by the ringing of the church bells in Boston, to give the alarm of fire. A central station transmits the electric current through a wire extending to the bells of some dozen churches. An electro magnet at or near each bell, disengages a catch, and the mechanism is put in motion, and the bell is rung a given time, and the hammer strikes the bell a given number of times to indicate the section of the city in which the fire is located.

The bell arrangement herein described is common to all electric telegraphs. I have described it, because I deemed it necessary to enable the reader to understand its application to the needle telegraph.

From the description of the English needle telegraph, the reader will see that it is not an "inefficient contrivance," but really an ingenious piece of mechanism, blending principles of science and art peculiarly simple, and at the same time wonderfully utilitarian. It is a perfect system, and has proved to be eminently practicable. A month's study and practice renders an operator capable of managing an instrument. Expertness follows practice and close application in the perfection of manipulation. An operator can send some 150 letters per minute, but the rapidity of the signals would be difficult to be understood. An expert can receive at the rate of 100 letters per minute. The usual rate is as fast as the receiver can conveniently write them.

COMBINING AND ARRANGING OF ELECTRIC CIRCUITS.

The arrangement of the wires on the English telegraph lines are apparently complicated, but in reality their connections are under the most perfect organization. To enable the reader to understand something more of the details of the English system, I have selected a few examples to illustrate the respective points referred to.

The North Kent Line, from London to Rochester, has a through group of five chief stations on one pair of wires; and two shorter groups, of six and seven stations respectively, on a second pair. They are all double-needle instruments, with

alarums on one of the needle wires. The branches to Tunbridge Wells, to Maidstone, to Ramsgate, to Deal, and to Margate have each a pair of wires for double-needle instruments at their stations, and a third wire for the alarum. At Tunbridge, the switchmen have single-needle instruments and alarums on one and the same wire. All stations are furnished with an earth-wire, and all groups must terminate in the earth.

The silent apparatus is an application of the earth-wire, as at Tunbridge, Ashford, and Folkestone, on the main line; and at Lewisham, Woolwich, and Gravesend, on the North Kent line. Take Tunbridge, for an example: wires 1 and 2 pursue an uninterrupted course from London to Dover, and include the Tunbridge instrument in their course; hence, if London makes a signal for Dover, or Dover for London, it must, of course, be visible at Tunbridge; and if Tunbridge makes a signal for London, it must be seen at Dover; because the circuit begins with the London earth-plate, and is continued by the unbroken wire to the Dover earth-plate; and, although not required at Dover, the current in this case must go there to get to the earth and complete the circuit. But if provided with a means of getting to the earth at Tunbridge, the long and unnecessary journey will be saved, and it will at once enter the earth at the nearest spot: if, therefore, when talking from Tunbridge with London, two small wires are carried from Tunbridge earth to the line-wires on the Dover side of the Tunbridge instrument, the line is cut short, and the signals are compelled to go only in the direction required, namely, up toward London: by putting the earth-wire on the other side of the Tunbridge instrument, signals are passed down the line only. The little arrangement, called the *silent apparatus*, is provided for performing this operation readily. Its face is seen at the lower part of the instrument, fig. 9, with an index, showing its position for either operation. Four springs, two from the wires on the London side of the instrument, and two from those on the Dover side, are resting on a boxwood cylinder ready for use. A slip of brass, in connection with the earth-wire, is inlaid in the wood; and by turning the cylinder in one direction, the slip of brass is brought into contact with the springs on the London side, and by turning it in the other, with those on the Dover side; thus connecting the up or the down wires respectively with the earth. This operation possesses a double advantage: by reducing the distance one half, it enables the station to work with less battery power; and by confining the signals to one half of the wires, it leaves the other half at liberty to other stations, and so on, while Tunbridge talks to London, Ashford may

talk on the continuation of the same wires to Dover. The name of this apparatus is derived from another adjustment with which it is provided: by pointing the index to the word "silent." is moved a brass slip into metal connection with the springs from either side of one of the electrometers, and another brass slip with those of the other electrometer; a short circuit is then made, and causes the sending station signals to appear on its own instrument only, and allow signals to pass on between other stations without entering its instrument; in fact, just as if the wires did not enter the Tunbridge station at all. The silent apparatus on the North Kent line is the same in principle, but different in construction.

By the above arrangement, all the line is provided with instruments, and no part is overcrowded; and an examination of the plan will show that when a station is not in direct communication with a group, it can hand its message on to a station that is; for instance, London gets a message to Penshurst by forwarding it *via* either Ryegate or Tunbridge.

Turn-plates.—Under common circumstances, the branch lines of telegraphs terminate at the junction stations—as the Deal branch at Minster, the Ramsgate at Ashford, the Maidstone at Tunbridge, the North Kent at London. But there are contrivances for turning on the branch wires at pleasure to the wires of the main line, somewhat as trains are turned by switches from one line of rails to another. The turn-plate is a cylinder of boxwood, inlaid with certain slips of brass, and mounted for protection withinside a small mahogany box; several steel springs press on either side of the cylinder, and are connected with terminals on the outside of the box; the wires are connected to these terminals. The slips of brass are so arranged that in one position of the cylinder the springs are connected into one set of pairs of springs, and by giving it a quarter of a revolution, they become connected into another set of pairs. In one case the two springs from the branch wires are connected respectively with springs from the earth-wire at the junction station, while the main line is open through from end to end; in the other case, the two springs from the branch wires become connected respectively with the two wires that lead up the line, while the two wires from down the line become connected with the earth at the junction station.

INTERIOR OF THE ENGLISH TELE- GRAPH STATIONS.

CHAPTER XV.

Interior Arrangements of a Station—Rate of Signalling—The Strand Telegraph Station—The Public Receiving Department—Blank Forms of the English Telegraphs.

INTERIOR ARRANGEMENTS OF A STATION.

It is my purpose, in the present chapter, to describe the interior of an English telegraph station, embracing the operating

Fig. 1.

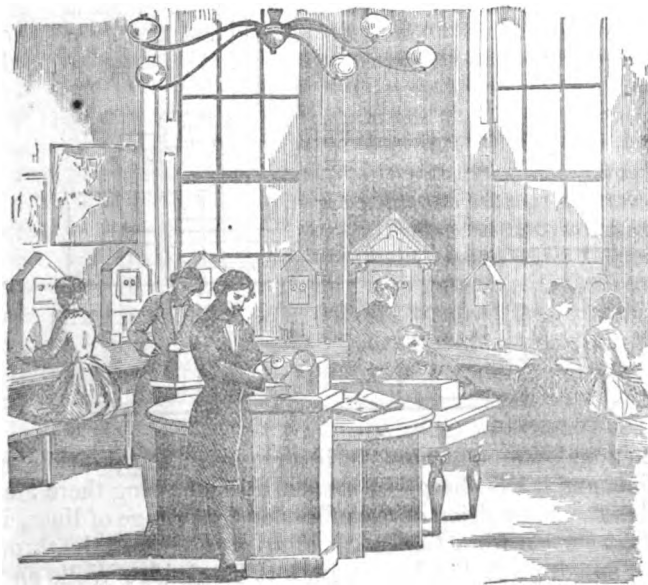

and the business departments. It will be impossible, however, for me to give a full account of the immense business details common to the larger stations, such, for example, as the Lothbury, in London. I will make my remarks general; but on such things as will be sufficient to enable the foreign telegrapher to comprehend the peculiar routine. In presenting these explanations, I will avail myself of the views expressed by Mr. Charles V. Walker, a distinguished telegraphic engineer, and to whom the world is much indebted for many valuable and important improvements in the art of electric telegraphing.

For the purpose of illustrating the organization of the interior of an office, I will first explain the wire connections, which will be seen illustrated in fig. 2, as arranged upon the interior wall of the station at Tunbridge. This station is just midway be-

Fig. 2.

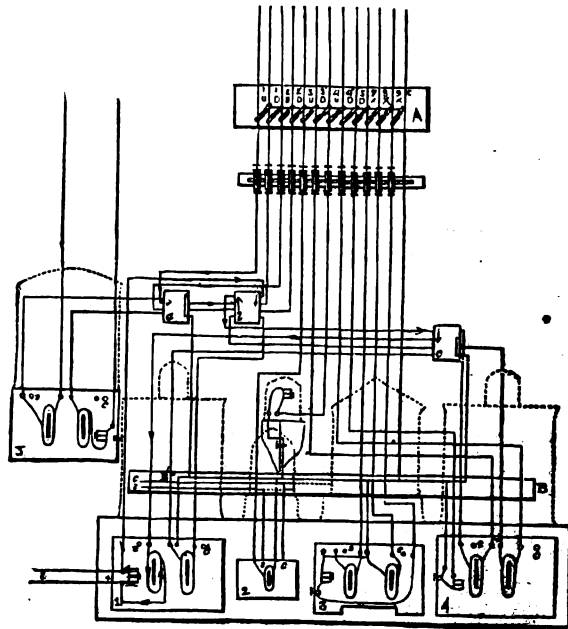

tween London and Dover. It is a commanding position upon the line, and it has charge of branch lines centring there; and, besides the supervision of the affairs on that range of lines, it is the first station from London, holding a position on the through wires, and from it the branch lines to Tunbridge Wells and to

Maidstone diverge. In regard to the station, Mr. Walker graphically writes, viz.:

“It is midway between the capital and the coast, and in a central position, in regard to the rest of the district. Here the conduct and management of the telegraph department is carried on: we have here our staff for maintaining the integrity of the line work, for cleaning and repairing the apparatus, and for keeping all stations supplied with battery power: and here we keep our stores. We befriend and assist all stations, and are their prime resource in time of distress and difficulty, helping on their messages when their own powers are crippled, and, under all circumstances, securing the successful working of the line.

Fig. 3.

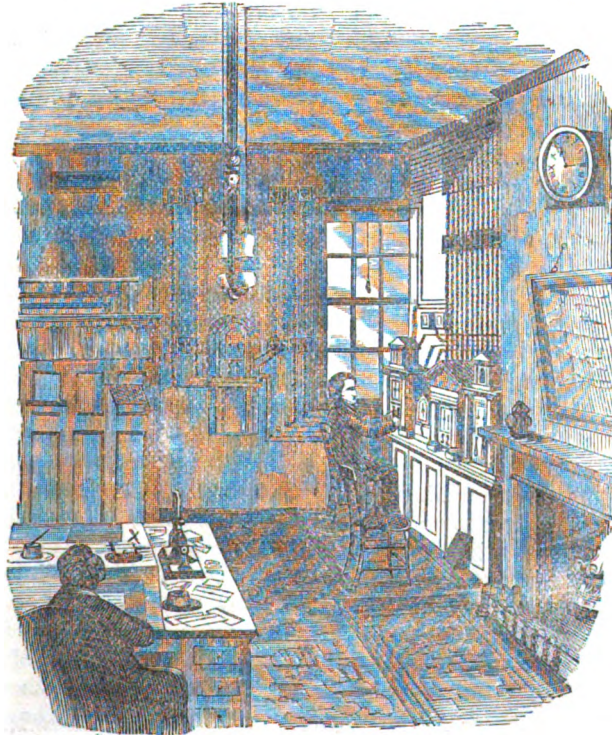

“ Fig. 3 is an accurate sketch of the interior of the Tunbridge office, just as it now appears. The telegraph table supports four instruments, and there is a fifth on a bracket on the wall. The

wires, which are cotton-covered copper, enter the room above the window, and passing on, are led in coils down the wainscot to their respective destinations. Some of the batteries are in the closet beneath the table, and others are in a battery-room across the station yard. The screen to the left is the Rubicon, beyond which, by the necessary rules of the telegraph service, the public are not allowed to pass.

“Fig. 2, which is drawn to scale, is a plan of the wires and instruments, shown in their places in fig. 3. The wires are numbered on their right to correspond. Nos. 7, 8, and 9, are the Tunbridge Wells wires; the letter *v* is put on the right side of the *up* wires, and the letter *d* on the *down* wires. An *up* wire is one that comes from the London side, a *down* wire from the Dover side. The last wire, marked *E*, is the earth wire, and is connected with the gas pipes.

“*A* is a mahogany tablet, carrying the old form of lightning conductors, one for each line-wire. A brass elbow, carrying points and a small ball, is attached to each wire, and a similar elbow is placed opposite to each, with the points and ball as near as possible to the other, without being in actual contact. This second set of elbows are screwed upon a slip of brass that leads from the earth-wire *E*, as shown at the upper part of the system. The principle is, that atmospheric charges, collected by the line-wires, shall discharge by the points or balls to the earth; and true enough, in thunder-storms, very vivid and loud discharges occur between these balls; but enough often remains to damage the instruments, so that these conductors are now rejected. The table next below *A* carries a set of lightning conductors on a new principle.

“*B* is a tablet carrying three brass rods. The upper one, *E*, is seen to be in connection with the earth-wire *E*, so that it is virtually a continuation of the earth-wire brought for convenience sake into near proximity to the back of the instruments. The others, marked *c* and *z*, are connected respectively with the copper and zinc ends of the battery. They extend along the tablet, and thus bring battery power close at hand to the instruments. I have drawn only a portion of them to prevent confusion.

“The table and its four instruments, shown in perspective in fig. 3, are here given in plan. The instrument next the window, at which the officer on duty is seated, is the through instrument, communicating with London and Dover. 2 is the single-needle instrument. It is the termination of a group, of which Ryegate is the commencement. 3 is one of two instruments, its companion being at Tunbridge Wells. 4 is the ter-

minal instrument of the Maidstone group; the other termination is at Maidstone. 5 is one of two instruments, its fellow being at my residence. To include it in this plan, I have moved it a little from its true position. The dotted lines are the outlines of the instruments themselves. The relation of these five instruments with those at other stations, may be readily gathered from the plan. On one instrument only, No. 2, have I shown how the terminals, *c* and *z*, are connected with the battery wires: brass wires are led down to them from the table *B*. I have shown the terminals *c* and *z* on the rest, but have omitted the wires to avoid crowding. I have given outlines of galvanometers and electro-magnets on all the instruments, that the connections may be traced. From the earth-wire *E*, a wire goes to all—to Nos. 1, 2, and 3, it passes *direct*, to 4 and 5 it arrives by a circuitous course, by the intervention of the turn-plates *a b c*. The wires that go from the *left-hand* side of the galvanometer all lead *up* the line, or toward London. Those from the *right-hand* side lead *down* the line, or *from* London. This may be seen by tracing the wires on the plan. When the wires cross in the plan, it must be understood that they do not touch each other. We can easily enough trace the wires that go uninterruptedly upward to the table *a*; but it requires some further description to understand what happens to those whose course is through a turn-plate.

“The turn-plate *c* is for putting the Maidstone branch in communication with London: the double action turn-plate *a* is for putting the superintendent's instrument into connecting with either London or Dover; the turn-plate *b* is for connecting both wires, either up or down the line, with the same needle coil, in the cases of connection between the line wires. I have not been able to give here a section of their cylinders, as the plan is on too small a scale. We will, however, show their application by tracing wire 1; first, while the through communication between London and Dover is open; and, secondly, when communication is established between London and Maidstone.

“Our first example will be the course of a signal passing from London to Dover. • I have marked out this course by small arrow-heads. It enters the station by wire 1 up, the first wire to the left; it is led to the left side of the turn-plate *a*, which it enters by the second terminal; it passes *through* the box and the cylinder, and out on the other side by the terminal immediately opposite: the cylinder in this position has a bit of brass for this wire inlaid on either side, and connected by a brass bolt running through the cylinder. The current now passes in a direct line to the turn-plate *b*, entering it by the second ter-

minal on the left-hand side, and passing in the direction of the contiguous arrow-head, leaving it by the first or upper terminal on the same side. In this drum, when thus arranged, there is inlaid a slip of brass, of sufficient length to allow the springs of both these terminals to press upon it. The current now goes on to turn-plate *c*, which it enters by the first or upper terminal on the left, and comes out by the second on the same side, the connection being exactly similar to that last described. It now pursues its course without interruption, to the telegraph instrument, which it enters on the left-hand side of the left-hand coil: it circulates around the coil; and, on leaving it, circulates round the coil of the electro-magnet belonging to the alarum. Its course is then to the upper terminal on the right-hand side of turn-plate *b*, coming out by the second terminal on the same side, and so leaving the station to continue its course to Dover by down wire No. 1, *d*.

“ We will now trace the course of the same up-wire 1, when the turn-plate *c* is so turned that London is put in communication with Maidstone. The current pursues the same course as before, until it arrives at the turn-plate *c*: it now enters it by the upper terminal on the left side, and passing through the box and drum, leaves it by the upper terminal on the right side; it then descends to the left-hand side of the left-hand coil of the Maidstone instrument, No. 4; passes round the coil, and continues its course to Maidstone by wire 3 down, which becomes the No. 1 of the Maidstone branch at Paddock Wood, as shown in the previous plan. But the turn-plates are so constructed, that while they make a particular connection for one part of the line, they provide perfectly for the part not so immediately concerned, by putting the wires that lead to that part in connection with the earth, and so the circuit is complete, as far as it goes. In the present instance, the same operation that turns 1 and 2 up-wires to Maidstone, connects the earth with the up side of the through instrument, and the communication is thus kept perfect between Dover and Tunbridge on the through instrument. By following with the eye, and in the reverse direction to the arrows, the wire that comes from the left coil of the through instrument, it is traced to the second terminal of the turn-plate *c*; the connection there is such, that the circuit is continued through the box and cylinder to the second terminal on the opposite side: this is in connection with the lower terminal on the same side, whence a wire descends to the common earth-wire. What has here been said of wire 1, equally holds good in respect to wire 2.

“ Turn-plate *a* has allowed the circuit of wire 1 up to enter

one side and pass over to the other ; but another position of the cylinder will close this circuit, and guide the current out by the terminal next above the one at which it enters. The wire from this terminal leads to the left side of the left coil of the instrument, No. 5 ; it passes out on the right side of the coil by the wire that passes upward, and which leads along part of the Tunbridge Wells branch line, and under the Hastings road to the companion-instrument in the superintendent's study.

“The action of this turn-plate may be better understood, by showing how it operates in its three positions upon the two wires that lead to it from the No. 5 instrument. When this circuit terminates at Tunbridge station the course of the current is *directly through* the box where there are three terminals, each connected with the earth by a common wire. When it is to be turned on and to terminate at London, the course is out of the box on the same side it enters ; and when it is to terminate in Dover the course is through the drum, but so contrived as to come out by the pair of wires that pass between the two boxes, the arrangements being such that the earth is in each case connected with the circuit not then in use.

“It would occupy too much time to describe the course of the whole series of wires ; but, from what has been said, the careful reader will have no difficulty in studying the disposition of each, as they are all faithfully traced and correctly numbered. And, by comparing this plan with the general plan of the line, there can be no great difficulty in connecting the special arrangements of this office with the general disposition of the line.

“The mode by which both wires, either *up* or *down*, are connected with the left needle, by turn-plate *b*, can be soon explained. When all is well the drum is so presented to the springs that strips of brass connect them in pairs, two pairs being on each side of the box. They were so connected when we traced the course of wire 1 just now. Suppose the wires *down* the line are connected, and it is desirable to join them both on the left needle-coil inside Tunbridge station : from the right-hand side of the box the top wire leads to the left needle, and the two middle wires are the down wires, we merely turn the cylinder and a long slip of brass presents itself, and presses on the three springs, connecting at once both wires with one needle, and leaving the other needle out of circuit. The same is done for the *up* wire by turning the handle in the reverse direction, and presenting the brass slip on the other side.

“The character of the bell circuit may be further illustrated from this plan. Wire 1 from London, in its course, after pass-

ing the left needle coil of No. 1 instrument has been seen to pass the bell-coil or electro-magnet, before it left the station on its way to Dover. The magnet would act and the bell ring; but if the bell-handle were turned, the current would mostly pass across at * by the stouter wires. These wires are continued round the room, and there is another bell-handle within reach of the clerk, who can make the short circuit at ‡ without leaving his desk.

“The Maidstone branch bell, No. 4, is on a third wire, distinct from the needle-coil. Wire 5, n, descends to the electro-magnet; it is continued from the magnet to the ringing key; it is thence led upward, and joined to the earth-wire e', on the tablet n. The Tunbridge Wells bell-wire 9 pursues a similar course; coming, however, first to the ringing key, and then to the electro-magnet, and away thence to the earth-wire. Wire 4, u, which comes from Ryegate, performs a similar office. I have given the outline of the bell-case, and the bracket on which it stands, to which latter the ringing-key is attached. As thus described, these three bells are always in circuit, and they are so arranged at all stations that have them; but here we have supplementary apparatus by which the short circuit can be made, when the noise of the bell, ringing for other stations, would interrupt business here.

“Fittings such as we have now described exist in all stations, limited in each according to the requirements of the station. But from this hasty sketch the most careless reader will have seen what great facilities may be gained by well-arranged means of intercommunication between the instruments. I might have enlarged upon the capabilities of this station, and have shown how we can take one part of a dispatch from Dover by the telegraph at one end of the table, at the same time we are sending another part on to London by that at the other; how we can cut off the line and test its character; how we can watch the variations in insulation or the augmentation of resistance, and feel out the weaker points and provide remedies; and how the eye of the chief officer of the department can command the whole line by night from his home, as well as by day from his office, and quick as thought can transmit instructions in all emergencies, in season and out of season; but I must pass on.”

RATE OF SIGNALLING.

The rate at which newspaper dispatches are transmitted from Dover to London, is a good illustration of the perfect state

to which the needle telegraph has attained, and of the apt manipulation of the officers in charge. The mail, which leaves Paris about mid-day, conveys to England dispatches containing the latest news, which are intended to appear in the whole impression of the morning paper. To this end, it is necessary that a copy be delivered to the editor in London about three o'clock, A. M. The dispatches are given to the telegrapher at Dover soon after the arrival of the boat, which, of course, depends on the wind and the weather. The officer on duty at Dover, having first hastily glanced through the manuscript, to see that all is clear to him and legible, calls London, and commences the transmission. The nature of these dispatches may be daily seen by reference to the *Times*. The miscellaneous character of the intelligence therein contained, and the continual fresh names of persons and places, make them a fair sample for illustrating the capabilities of the electric telegraph as it now is. The clerk, who is all alone, placing the paper before him in a good light, and seated at the instrument, delivers the dispatch, letter by letter, and word by word, to his correspondent in London; and, although the eye is transferred rapidly from the manuscript copy to the telegraph instrument, and both hands are occupied at the latter, he very rarely has cause to pause in his progress, and as rarely also does he commit an error. And, on account of the extremely limited time within which the whole operation must be compressed, he is not able, like the printer, to correct his copy.

At London, there are two clerks on duty, one to read the signals as they come, and the other to write. They have previously arranged their books and papers; and, as soon as the signal for preparation is given, the writer sits before his manifold book, and the reader gives him distinctly word for word as it arrives: meanwhile, a messenger has been dispatched for a cab, which now waits in readiness. When the dispatch is completed, the clerk who has received it, reads through the manuscript of the other, in order to see that he has not misunderstood him in any word. The hours and minutes of commencing and ending are noted, and the copy being signed, is sent under official seal to its destination, the manifold facsimile being retained as the office copy, to authenticate verbatim what has been delivered. This copy and the original meet together at the chief telegraph office at Tunbridge, early in the day, and are compared. When the work is over, and the dispatches have reached their destination, the clerks count over the number of words and the number of minutes, and find the rate per minute. From twelve to fifteen words per minute has become

a very ordinary rate; seventeen or eighteen words per minute is of very common occurrence, and even twenty words. Indeed, when all is well, and the insulation is good, seventeen or eighteen words is likely to be the average.

In 1849, Mr. Walker selected eleven messages, the minimum of which was 73 words, and the maximum was 364 words. The aggregate number of words was 2,638. The total time occupied in the transmission of these eleven messages was 162 minutes, making an average of $16\frac{1}{4}$ words per minute.

In 1854, while I was in London, Mr. Foudrinier, the secretary of the Electric Telegraph Company, instituted an inquiry in regard to the celerity of the signalling then in practice. He selected eleven messages, containing in the aggregate 244 words, and the time required to transmit them was 689 seconds, or at the rate of $21\frac{1}{4}$ words per minute. This trial was made on the English double-needle telegraph. At this experiment, the minimum celerity was $16\frac{2}{3}$ words per minute, and the maximum was $24\frac{1}{2}$ words per minute.

While visiting the office of the Magnetic Telegraph Company, in Liverpool, in 1854, I was informed by the brothers Bright, that, with their apparatus, the average celerity attained at a trial was $27\frac{1}{3}$ words per minute; the maximum was $37\frac{1}{8}$ words per minute. The apparatus used by the Magnetic Company is described elsewhere in this work, as employing magneto-electricity. An opinion is entertained by the friends of this improvement, that the increased celerity in the last experiments cited, was owing to the use of this species of electricity.

THE STRAND TELEGRAPH STATION.

I have explained to the reader the arrangement of the wires in a station, and there is but little left for me to say in regard to the operating department. Fig. 1 is a view of the operating room of the telegraph office on the Strand, Charing Cross, London. I have visited this office frequently, and I recognize the drawing as very correct. In this office, I saw several young ladies employed in the service of the company. To the right, in the figure, are two ladies seated, one of them is watching the signals, and repeating the words thus formed to the other, who is engaged in writing the message as thus given. At the centre apparatus is a male operator transmitting; and to the left is a female operator, also transmitting. In the middle, sitting by a table, is employed a clerk, preparing the messages for delivery. In front and to the left, are two male operators engaged in sending by the Bain chemical telegraph instru-

ments. This room is on the second floor. On the first floor is the public reception-room. Figs. 2 and 3 have been already described.

THE PUBLIC RECEIVING DEPARTMENT.

Fig. 4.

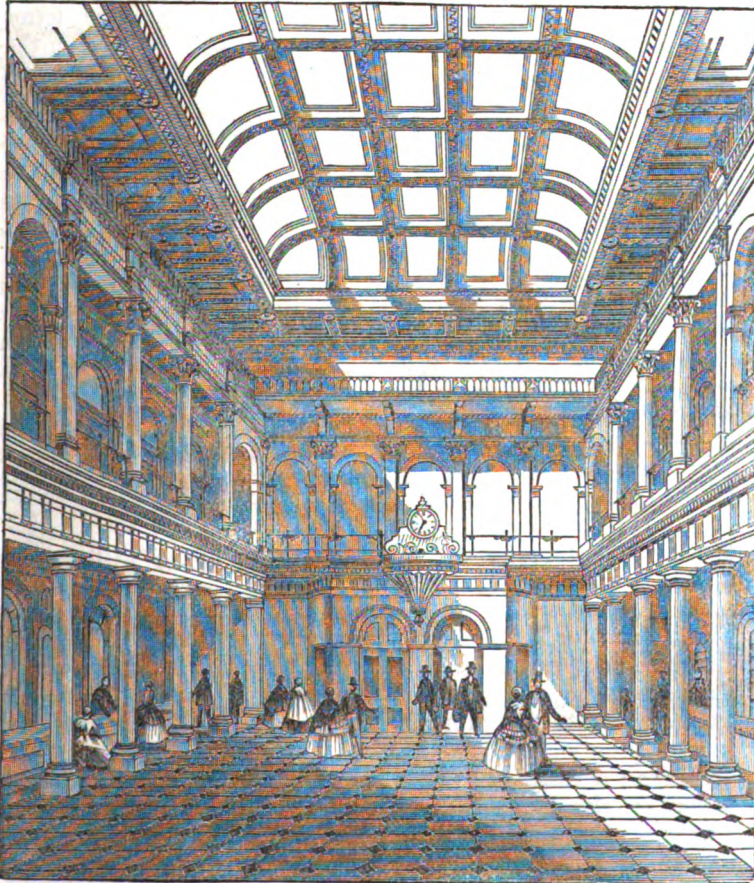

The public business room of the station is separate from the operating department. Fig. 4 represents the receiving room of the great Lothbury station, London. In this room will be found

one or more clerks for the reception of dispatches from the public. Arrangements are made to give the public an opportunity to prepare their messages in private; no one can overlook and see what another is writing. Great regard has been given to this subject. Blanks are furnished, and upon these blanks are written the message desired to be sent, and all dispatches offered must be signed by the sender. If messages are brought into an office on plain paper, the person bringing such is requested to copy the communication upon the printed forms provided by the company. If it is not copied or written on the company's forms, it is refused. If the customer cannot write, one of the company's clerks copies the message, reads it to the customer, keeps the original, and obtains the signature or mark of the person, at the foot of the company's paper. The message is then sent, the company being free from liability.

Printed forms have been used by the telegraph companies in England from the first established lines. The difference of cost between ordinary paper and the printed forms is very small, and the printed headings facilitate the registration; and the defined position of the address from and to, and of the body of the message, materially aids the instrument clerk in forwarding the communication. To all good customers small books of forms are issued. Larger books lie at the places of general resort (such as the exchanges, reading rooms, &c., &c.); while casual customers find forms ready at the company's offices upon counters of a height suited for writing, when standing, and subdivided into spaces, with fluted glass screens between each, to prevent, as before stated, any person seeing another's message.

As a commercial affair the companies regard the use of the blank forms as indispensably necessary, so that the stipulations thereon printed shall become the conditions upon which the company agrees to send the message, and upon which the sender presents the same for transmission, all duly signed by him.

When the message is thus presented, every condition contained on the blank forms a contract. Being legally signed by the sender completes it upon his part. The reception of the money for its transmission by the company, completes the contract by both parties. They are from that moment bound and responsible according to the stipulations therein set forth, and from which neither party can recede without the consent of the other.

The company's cashier quickly counts the words in the body of the message (the address not being included, but passing

free), endorses the message, and writes a receipt of the amount; the customer is handed the *receipt*, upon the money being paid. Parties sending messages are advised to write them distinctly; and the cashier reads the message, in order to see that the writing is legible, before handing it through to the instrument room.

The cashier enters upon a list, opposite to the consecutive number of the message, the amount received; and, on being passed through to the instrument room, the lad receiving the message marks the number upon a similar list, and sends the message to the instrument for which it is intended. The clerk at the instrument then dispatches it to or toward its destination, receiving an affirmative or negative signal after each word; if the latter, the word is repeated, not having been rightly understood by the receiving clerk at the distant station. So commencing the message, the *sending* clerk signals the number of words the message contains (previously inscribed on the paper by the cashier), and, as soon as completed, the *receiving* clerk's writer counts the number of words received, to see that the message is correct as to length; and, as will have been seen, the "understand" or "not understand" signals after each word, check the words themselves—admitting, when the system is carefully carried out, of little possibility of mistake.

In the foregoing I have embodied the routine observed in the *chief* stations. In small stations, where there is no great influx of messages, the checking is not carried out to such an extent.

As soon as the message has been sent, it is returned to the checking lad, who files it, and draws his pen through its consecutive number, to intimate that, as far as the due forwarding is concerned, the company have performed their duty, and it is his business to see that the signal clerk has endorsed upon the document the time at which he sent it, the station to which he signalled it, and his initials. By such an arrangement all chance of a message being mislaid is avoided; as, if the communication is not returned in a quarter of an hour to have its number marked off the list, it is the duty of the checking clerk to inquire after it, and to ascertain why it has not been dispatched.

Very little time is lost in such an arrangement, and the chance of error of any nature greatly diminished.

BUSINESS FORMS OF THE ENGLISH TELEGRAPHS.

I annex a series of blank forms used by the respective telegraph companies in Great Britain. They are herein presented in their adopted form, and about the same size, as those in use by the lines in England. I also give the blank receipts and account forms.

Document A is a blank form, which is used by the public in the presentation of a message, to be transmitted by the telegraph company. The two pages represent the face of the blank form in which the message is written, and the heading is to be filled by the company's clerk. The patron signs the message. Documents B and C are printed on the back of the sheet on which the message is written, represented by document A.

These forms present the tariff of insurance and assumed responsibility. Document D is the head or caption of a message as sent to the public. The face of the sheet is about the size of the usual letter paper, only half of the blank being represented by document D.

Document E is a blank used by the companies for messages received from a distant office, and which is to be transmitted further by another line. The size of this blank is the same as document A, only half of the sheet being represented. The forms at the bottom of the page are to be filled, and then sent to the next line. In order to prevent confusion, the blanks are printed in different colored inks.

Document F is the form of an account sent out with the messenger, accompanying a message for collection.

Document G is the form of a receipt given the customer, on the reception of his message for transmission, at the counter of the company by the cashier.

Doc. B.

THE ELECTRIC TELEGRAPH COMPANY.

CONDITIONS AS TO UNINSURED MESSAGES.

The Public are informed that, in order to provide against Mistakes in the transmission of MESSAGES by the ELECTRIC TELEGRAPH, every Message of consequence ought to be REPEATED by being sent back from the Station at which it is to be received, to the Station from which it is originally sent. Half the usual price for transmission will be charged for repeating the Message. The Company will not be responsible for Mistakes in the transmission of unrepeated Messages, from whatever cause they may arise. Nor will the Company be responsible for Mistakes in the transmission of a repeated Message, nor for delay in the transmission or delivery, nor for non-transmission or non-delivery of any Message, whether repeated or unrepeated, to any extent above £5, unless it be insured.

Correctness in the transmission of Messages can be Insured at the following rates in addition to the usual charge for repetition —

	£ s. d.	£ s. d.	£ s. d.
For any Sum up to £100	1 0 0	Above £400 to £500	5 0 0
Above £100 to £200	2 0 0	Above £500 to £600	6 0 0
£200 to £300	3 0 0	£600 to £700	7 0 0
£300 to £400	4 0 0	Above £700 to £ 800	8 0 0
		£800 to £ 900	9 0 0
		£900 to £1000	10 0 0

and 20s. for every £100, or fraction of £100 above that sum; and the Company will not be responsible for any amount beyond the sum for which the Message is insured and the rates paid.—The Company will not be responsible in any case for delays arising from interruptions in the working of their Telegraphs.

J. L. RICARDO, *Chairman.*

Doc. A.

THE ELECTRIC TELEGRAPH COMPANY.

STATION

Prefix..... Code Time..... No.....

Received..... } m } Date..... 185 }
 Finished..... } m } Sent to..... Station.

by me..... Clerk.

Message..... " "
 Repeating..... " "
 Reply..... " "
 Portage..... " "
 To be paid out.. " "
 Total..... " "

(All numbers must be written at length in words.)

PLEASE TO SEND THE FOLLOWING UNNUMBERED MESSAGE ACCORDING TO THE CONDITIONS EMBODIED HEREON.

FROM

TO

Name and Address of the Sender of the Message.....

Name and full Address of the Person to whom the Message is to be delivered.....

.....

.....

.....

.....

Before Signing, please to see that the amount to be charged for the Message is correctly entered above, and on the receipt, and read the endorsed Conditions.

Signature and Address of Sender.

The Company will not be answerable for Errors caused by indistinct writing.



Doc. C.

NOTICE.—Messages to be sent to any places beyond the extent of the Company's Lines or Stations, will be delivered by the Company's officers at their terminal Station mentioned in the subjoined request, to such parties as may have charge of the further means of conveyance; but it is expressly provided that the Company are in no case to be held responsible for the transmission or delivery of the Message beyond the terminal Station in such request mentioned.

(REQUEST.)

*I request that this Message may be forwarded from the Company's Office at _____
(being the Terminal Station of the Company) by _____*

*to the address mentioned therein, subject to the above conditions, and have deposited _____
to be applied for that purpose.*

Signed _____

Doc. D.

THE ELECTRIC TELEGRAPH COMPANY.

Code	}	No. of Words
Time		

LONDON STATION.

Received the following Message { At _____ h _____ m the _____ day of _____ 185

Signed _____ Clerk.

From Name _____ Address _____	To	Name _____ Address _____
-------------------------------------	----	-----------------------------

⚠ No inquiry respecting this Message can be attended to without the production of this paper.

Doc. E.

THE ELECTRIC TELEGRAPH COMPANY.

From..... *Station*. *Code Time*..... *Station*.
To..... *Station*. *No. of Words*..... 185

[The Form contains full space between these lines for a Message of fifty or more words in length. I omit the space.]

RECEIVED.

SENT.

Com.....*h*.....*m*. *Sd*.
Fin.....*h*.....*m*.

Com.....*h*.....*m*. *Sd*.
Fin.....*h*.....*m*.

Doc. F.

THE ELECTRIC TELEGRAPH COMPANY. No.

_____ 185

Messenger's Name _____

For _____

H. M.

Sent out . . . _____ M.

Received at _____ M.

Returned at _____ M.

Signature of Receiver _____

Charges to Pay _____

Clerk's Initials _____

N. B.—You are requested to give no fee or gratuity to the Messenger, and pay no charges beyond those entered in this sheet.

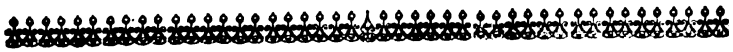

Doc. G.

THE ELECTRIC TELEGRAPH COMPANY

LONDON STATION.

Date _____ 185

No. _____ Time received, _____ No. of Words } _____

From _____

Message " "

Porterage " "

Paid out " "

To _____

Total " "

Signed _____ Clerk

AVY'S ELECTRO-CHEMICAL TELEGRAPH.

CHAPTER XVI.

Nature of the Invention described—The Transmitting Apparatus—The Receiver—The Instruments combined—The Manipulation—The Signal Alphabet.

NATURE OF THE INVENTION DESCRIBED.

ON the 4th of July, 1838, was sealed a patent to Mr. Edward Davy, of England, for an electric telegraph, which combined the fundamental elements of subsequent chemical systems. The patent was very extensive, and embraced many valuable improvements in the art. It was bought by the Electric Telegraph Company of England, but never used.

The following outline description of the invention will serve to give an idea of its combinations :

Three wires were to be used, and points of metal wire were to be caused to press, by means of the motion of magnetic needles, upon chemically prepared fabric at the distant or receiving station.

The fabric to be employed was calico or paper, and it was to be moistened with a solution of hydriodate of potash and muriate of lime.

The motion of a needle to the right caused a mark to be made on *one* part of the fabric, and the motion of the same needle to the left, caused a mark to be made on *another* part of the fabric; and the same for *each* needle attached to the respective wires. Thus the single or combined marks were made to express letters or other desired symbols.

THE TRANSMITTING APPARATUS.

Fig. 1 represents a top view of the arrangement of the wires, mercury cups, and batteries of the *transmitting station*. The close parallel lines represent the wires, of which *D A B* and

c are those which proceed to the receiving station. 1' 2' and 3' are the three batteries, of which P and N are their respective

Fig. 1.

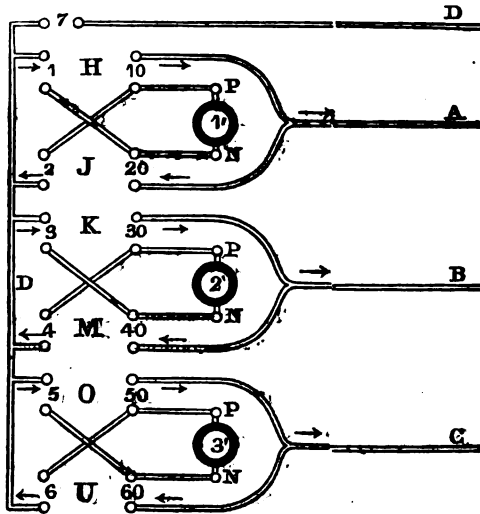

poles. The small circles formed at the termination of the wires, and marked 7, 1, 10, 2, 20, &c., are mercury cups, in which the terminating wires are immersed. The wires 1 and 20, and 2 and 10, &c., which cross each other, are not in contact, but perfectly insulated. The wires shown in this figure are all

Fig. 2.

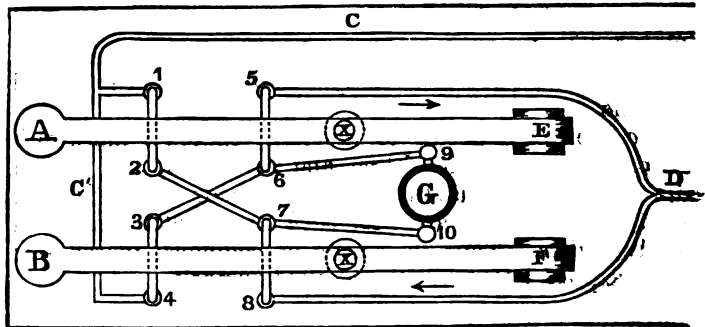

secured permanently, with their mercury cups to one common base-board. The letters H J K M O and U represent the places of the six finger-keys used in transmitting signals. There is

also another key at 7, for uniting the wire *d* and *d*. In this figure, however, the keys themselves are omitted, in order to render more clear the arrangement of wires under and around them. Another figure, 2, is here introduced to illustrate the plan of one set of wires and their two keys. In fig. 2 is represented, in a top view, the two wooden keys, *A* and *B*, and their axes, at *E* and *F*. *G* is the battery, of which 9 is the positive pole, and 10 the negative pole. The small circles, marked 1, 2, 3, 4, 5, 6, 7, and 8, represent the mercury cups. *c* and *c'*, and also *d*, are the extended wires. The keys, *A* and *B*, have each two wires, passing at right angles through the wooden lever. The wires of the key *A* are marked 1 and 2, and 5 and 6, and those of the key *B* are marked 3 and 4, and 7 and 8. These wires, directly over the mercury cups, are bent down a convenient length, so as to become immersed in the cups, when the lever is depressed, and rise out of them, when the lever is elevated. Now, if the key *A* is depressed, the cup 1 is brought in connection with cup 2; and 5 is connected with 6 by the wires, supported by the lever, being immersed in the mercury; and the key *B* not being depressed, there is no connection of the cup 3 with 4, or 7 with 8. At *x* and *x*, under the lever, are springs, which keep the lever elevated, and, consequently, the wires out of the cups, when the keys are not pressed down.

Fig. 3.

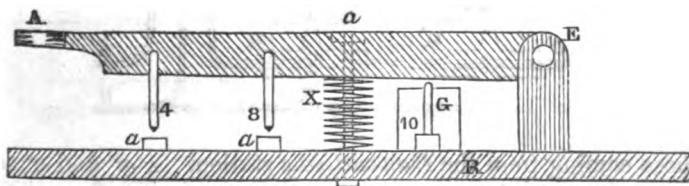

Fig. 3 represents a side view of the lever or key *A*, and its axis at *E*. *R* is the platform supporting the standard of the axis, the stationary wires, the battery *G*, and the mercury cups, *a a* and 10. *x* is the spiral spring, for the purpose of carrying back the lever, after the finger is taken off, and sustaining it in its elevated position. Through the centre of the spiral passes a rod, with a head upon it at the top of the lever, to limit its upward motion. At its lower end, the rod is secured in the platform *R*. 4 and 8 are the two wires supported by the lever *A*, and are seen to project down directly over the mercury cups, *a* and *a*, so that by depressing the key, they both enter the cups

and form a metallic connection. The key B, fig. 2, has the same fixtures, and is similarly arranged as the key A, fig. 3.

THE RECEIVING INSTRUMENT.

Fig. 4 represents a top view of the arrangement of multipliers at the *receiving* station. R' R' R' and R R R are six magnetic needles or bars, each of which move freely on a vertical axis passing through their centres. The lower point of their axes is immersed in cups of mercury, in which also terminate the wires I I I and L L L. The wires D'' A' B' and C' are

Fig. 4.

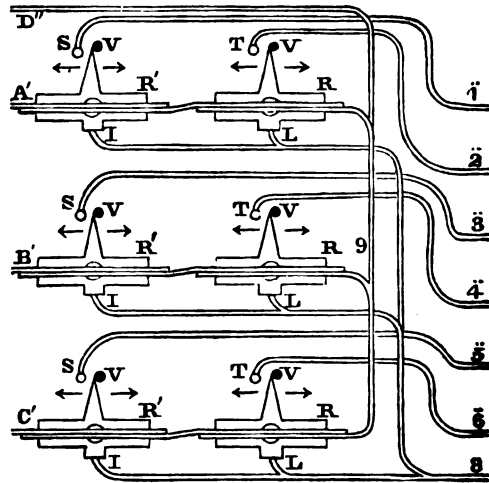

those coming from the *transmitting* station. A' B' and C' each enter the needle arrangement, and first passing from left to right *over* the magnetic bars R' R' R' and R', in the direction of their length, then down and under and round, making many turns, leave these three needles and pass *under* the needles R R R and R, and in like manner from right to left round them, making a number of turns, then pass off and unite together in the wire 9, which is a continuation of D''. This wire is called the *common communicating wire*, and the wires A' B' and C' are called *signal wires*, though they too are occasionally common communicating wires. At right angles, there projects from each magnetic bar a metallic tapered arm, which rests against the studs v v v v v, when the needle is undisturbed. But when the needles are made to move in the direction to carry the arms

to the left, they are brought in contact with the metallic stops $s s s$ and $\tau \tau \tau$. To each of these stops, it will be observed, a wire is soldered, and continued respectively from $s s s$ to $\dot{1} \ddot{3} \ddot{5}$, and from $\tau \tau \tau$ to $\ddot{2} \ddot{4} \ddot{6}$. It will also be observed, that, from each of the mercury cups below the magnet bars, the wires i and L and i and L , and i and L proceed and unite in pairs at $L L L$; these three united wires are then continued, and the whole are joined in one at 8. The wires $\dot{1} \ddot{2} \ddot{3} \ddot{4} \ddot{5} \ddot{6}$ are continued, in a manner hereafter to be described, and are connected with one pole of a battery. The wire 8 is also continued and connected with the other pole. So that if any one of the needles should be made to move its arm to the left, thereby coming in contact with its metallic stop, the circuit would be complete, and the current would pass along the wire $\dot{1}$, for example, to the metallic stop, then to the arm, and to the magnetic bar, then to the axis, then to the mercury, then to the wire i , and thence to the wire 8. In the same manner the current would pass, if any other arm was brought against *its* metallic stop.

THE INSTRUMENTS COMBINED.

In order to understand the combined operation of the keys and needles, fig. 5 is here introduced. The right-hand figure is the same as fig. 4, and the left hand the same as fig. 1.

Fig. 5.

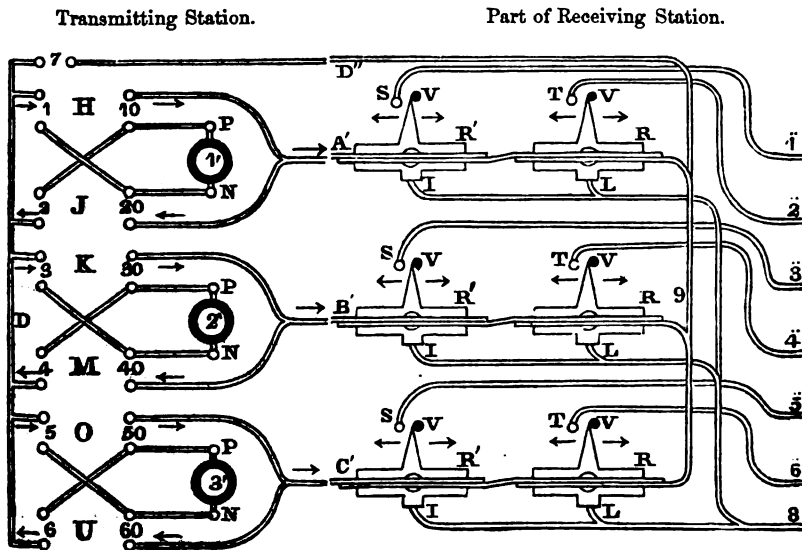

The wires d'' a' b' and c' are detached from their corresponding wires of the transmitting station, and it may be imagined that many miles of wire intervene and connect the two. In the left-hand figure, those mercury cups above and below 1 and 10, are joined by two wires passing through a moving lever, in the same manner as has been described in fig. 2. We will; therefore, call the key carrying these two connecting wires h . In like manner the key for the cups above and below the numbers 2 and 20, is called i ; for 3 and 30, is k ; for 4 and 40, is m ; for 5 and 50, is o ; for 6 and 60 is u . The key which connects the two mercury cups on the right and left of number 7, of the wire d'' , is called 7. There are 7 keys, two for each battery, 1' 2' and 3', and each wire a' b' c' , and one for the common wire d'' .

It will now appear, that if the key u and 7 are depressed, the cups above and below numbers 6 and 60, and the cups on each side of number 7, will be connected together, so that the current leaving p , or the positive pole of the battery 3', goes to the lower cup 50; then by the stationary cross-wire to upper cup 6; then passes to lower cup 6, by the wire supported by the lever u , which is now pressed down, and its ends immersed in the two cups; then along the wire d , to the left-hand cup 7; then to the right-hand cup 7, by the wire supported by the lever 7, and which is immersed in the two cups; then through the extended wire to d'' , of the *receiving* station; then through 9, to the two multiplying coils of the wire c' , deflecting the arm of the needle r to the right, against the stop v , and the arm of the needle r' to the left, against the metallic stop s , as indicated by the arrow at s ; then along the extended wire, back to the lower cup 60, of the *transmitting* station; then to upper cup 60, through the wire supported by the lever u ; then to n , the negative pole of the battery 3'.

It will be observed of the two needles, r and r' , in the circuit of the same wire c' , that if r is deflected to the right against the stop v , then r' will be deflected to the left against the metallic stop s . The current, to produce these deflections, is through the wire c' , in the contrary direction to that indicated by the arrow of wire c' . But if r is deflected to the left against the metallic stop r , then r' will be deflected to the right against the stop v . The current to produce these deflections will then be through the wire c' , in the direction of the arrow of that wire. The same effect is produced upon the two other pairs of needles of the wires a' , and also b' . These contrary movements of the two needles, when a current is passing, are produced by the coils being so wound (as described with fig. 4), that the wire passes round one needle in a contrary direction to what it does round the other.

THE MANIPULATION DESCRIBED.

If the keys *o* and *7* be depressed, the cups above and below, *5* and *50*, and on each side of number *7*, will be connected. The fluid will then pass from *r*, or positive pole of the battery *3'*, to the lower cup *50*; then through the key wire to upper cup *50*; then along the extended wire *c'* to the *receiving* station; then through the coils of the multipliers, deflecting the arm of the needle *n* to the left against the metallic stop *r*; and the arm of the needle *n'* to the right against the stop *v*, as indicated by the arrow at *v*; then to wire *9* and *d''*; then along the extended wire back to the *transmitting* station, to the right hand cup *7*; then by the key wire to the left-hand cup *7*; then to wire *d*; then to upper cup *5*, and through the key wire to lower cup *5*; then by the cross wire to upper cup *60*, and then to *n*, or negative pole of the battery.

It has now been shown the route of the current, when the keys *v* and *7*, and the keys *o* and *7* were depressed. It will be observed, that when the keys *v* and *7* were used, the current through the wire *d''* was from *left* to *right*; and when the keys *o* and *7* were used, the current was from *right* to *left*. Thus, by means of the six keys, the current of each battery may be made to pass in either direction through the *common communicating* wire *d''*. By the keys *u m j*, with *7*, the current is made to pass from *left* to *right* along the wire *d''*. By the keys *o k n*, with *7*, the current is made to pass from *right* to *left* along the wire *d''*. By these six keys all those various deflections of the six needles are produced, which are necessary to close the circuit of such of the wires $\dot{1} \dot{2} \dot{3} \dot{4} \dot{5} \dot{6}$, with the wire *8*, as are required for making the signals desired, on an instrument now to be described.

Fig. 6 represents a top view of that part of the instrument at the *receiving* station, by which the signals are recorded. The seven wires on the left of the figure are a continuation of these wires, marked $\dot{1} \dot{2} \dot{3} \dot{4} \dot{5} \dot{6}$ and *8*, in fig. 5. The first six pass through a wooden support, *b b*, and terminate on the edge of the platinum rings *a a a a a* and *a*, forming a metallic contact. The six platinum rings surround a wooden insulating cylinder *t*, which revolves upon axes in the standards *h* and *i*. The rings are *broad* where they come in contact with the wooden roller, and are bevelled to an *edge* where they come in contact with the six wires. *v* represents a compound battery, with one pole of which wire *8*, from the needle arrangement, fig. 5, is connected, and from the other pole the wire proceeds to the electro-magnet *z z*; it then passes on, and is brought in connec-

tion with the metallic cylinder *d*, at the point *g*. The cylinder *d* revolves upon an axis, and is supported in the standards *k* and *l*.

Fig. 6.

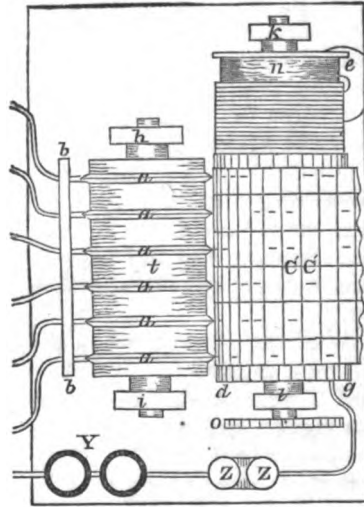

To the cylinder is attached a barrel *n*, upon which is wound a cord, supporting the weight *e*, by which the cylinder is made to revolve. *c' c'* represents a prepared fabric, such as calico, impregnated with hydriodate of potash and muriate of lime, and is placed between the platinum rings *a a a a a*, and the metallic cylinder *d*; *o* is a cog-wheel upon the end of the axis of the cylinder *d*, and is connected with other machinery, omitted here, but shown in fig. 7, which is a side elevation of part of fig. 6; *o* is the cog-wheel, fig. 7, on the arbor of the cylinder *d*. *B* and *B* are the two sides of the frame containing the clockwork, and is secured to

the platform *r*; *d* is part only of the metallic cylinder, upon which is seen a portion of the prepared fabric *κ*. The cog-wheel *o* drives the pinion *A*, and the shaft of the fly-vane *c*. *M* is an

Fig. 7.

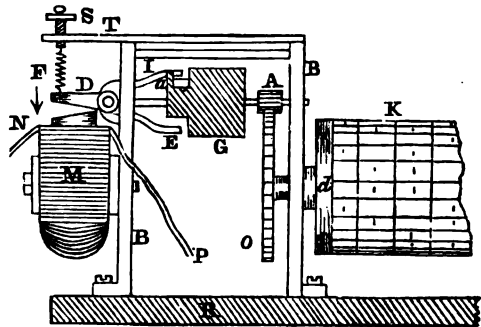

end view of the electro-magnet, represented by *z z*, in fig. 6, of which *n* and *p* are the two ends of the wire composing the helix.

D is its armature, constructed so as to move upon an axis represented by two small circles. To the armature are connected, and capable of moving with it, two arms, E and I, which project, so as to come in contact with the pallet *a* of the fly G. F is a spiral spring, one end of which is fastened to the armature D, and the other passes through a vertical hole in the screw s, in the bar r, by which the armature is held up in the position now seen, when not attracted by the electro-magnet. Now, if the wires *x* and *r* connected with battery *y*, fig. 6, have their circuit closed, the current passing through the helix of the magnet *m*, brings down the armature D in the direction of the arrow, which raises the arm I, against which the pallet *a* of the fly-vane is resting, and releases the fly. It then makes a half revolution, and is again arrested by the pallet against the lower arm E, and the cylinder D, with its fabric, has advanced a half division. If the circuit is now broken, the armature D is carried up by the spring F, at the same time the arm E releases the pallet *a*, and the fly makes another half revolution, and is again stopped by the arm I. The cylinder now advances another half division, making a whole division the fabric has advanced. The purposes for which this is designed will now be described.

Fig. 8.

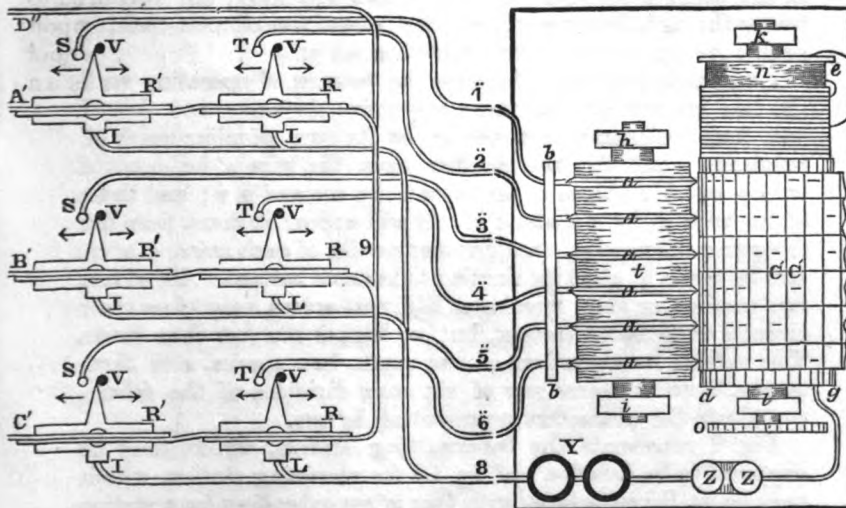

Fig. 8 represents a top view of the whole apparatus of the receiving station. The fabric, *c' c'*, is marked in equal divisions across it, and in six equal divisions in the direction of its

length, thus marking it into squares. Each platinum ring, *a a*, &c., when the instrument is not in operation, is in contact with the fabric at the *middle* of the squares across the fabric. It will be observed, that the wires 1 2 3 4 5 6 are in connection with the battery γ and the circuit complete, except at the arms of the needles. Suppose, for example, the arm of the needle κ' of the wire c' , is brought up against the stop of the wire 5, at *s*, the circuit is then closed, and the current leaves the battery, and passes to the electro-magnet, causing the cylinder and fabric to move half a division, then to the metallic cylinder *d*; then through the fabric $c' c'$, resting upon the cylinder, where it is in contact with the platinum ring *a*, of the wire 5, then to the platinum ring, then to wire 5, then to the metallic stop *s*, then to the arm of the needle κ' , along its axis to the mercury, then to the wire 1, then to the wire 8, and to the other pole of the battery γ . Thus the current is passed through the prepared fabric, and a mark produced thereon in the middle of its square. If the circuit is now broken, the cylinder moves another half division, which will bring the rings to the centre of the squares, ready for the next signal.

But one battery, γ , is used for all the six circuits, formed with the wire 8, so that, when three of the circuits are closed at the same instant, as will be shown hereafter, the current passes through the three wires of their respective circuits, making each their appropriate mark upon the fabric.

I will now proceed to describe the manner of operating with the two instruments, at their respective stations: and, first, I will here designate each needle by its own peculiar mark of reference. Let the two needles upon the wire A' be denoted by $A s$ and $A r$; those of the wire B' by $B s$ and $B r$; and those of the wire C' , by $C s$ and $C r$. It will appear obvious, from the foregoing description, that but *one* needle of each wire, $A' B' C'$, can be made to close its circuit at the same instant. However, *two* needles, or *three* needles of *different* wires, may close their circuits at the same instant, but no higher number than three. The various combinations of *one* mark, *two* marks, and *three* marks, upon the same row of six cross divisions of the fabric, constitute the characters representing letters.

Fig. 9 represents the *transmitting* station, which may be supposed to be *London*, and fig. 10 the *receiving* station, which may be at *Birmingham*, with four wires extending from station to station, or three only, if the *ground* be substituted for the wire D'' . Now, if the keys be depressed, the following deflections of the two needles of each key will be produced:

Fig. 9. LONDON—Transmitting Station. Fig. 10. BIRMINGHAM—Receiving Station.

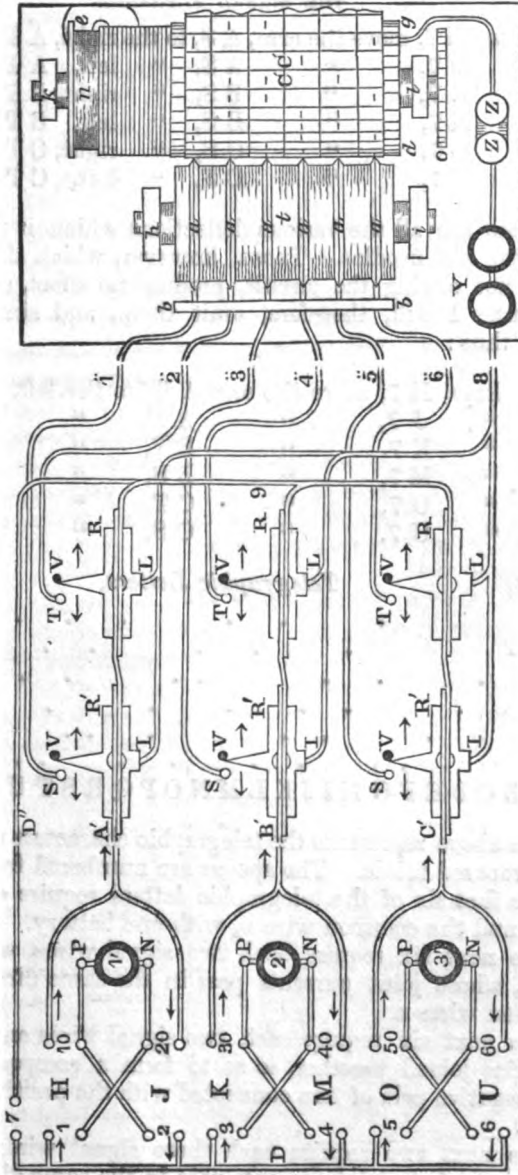

THE SIGNAL ALPHABET.

The keys, H 7, move the arm, A S, to the right, A T, to the left.
 " J 7, " A S, " left, A T, " right.
 " K 7, " B S, " right, B T, " left.
 " M 7, " B S, " left, B T, " right.
 " O 7, " C S, " right, C T, " left.
 " U 7, " C S, " left, C T, " right.

These are all the various deflections which it is possible to give the six needles. Those, however, which deflect to the right, not closing the circuit, produce no effect, and are of no account. I will, therefore, omit them, and simply give the table, thus :

The keys, H 7, move the arm	A T, to the left.	No. 1.
" J 7,	" A S, " left,	" 2.
" K 7,	" B T, " right,	" 3.
" M 7,	" B S, " left,	" 4.
" O 7,	" C T, " right,	" 5.
" U 7,	" C S, " left,	" 6.

Telegraphic Letters.

1						
2						
3						
4						
5						
6						
	A	B	C	D	E	F	G	H	I	J	K	L	M	N	O	P	Q	R	S	T	U	V	W	X	Y	Z

The above represents the telegraphic characters marked upon the prepared fabric. The spaces are numbered from the top.

The first six of the telegraphic letters require each a signal wire, and the common wire D, with one battery.

The next six require each two signal wires, with two batteries, whose joint currents pass in the same direction on the common wires D.

The next six require each two signal wires only, with two batteries joined together, so as to form a compound battery; the negative pole of one connected with the positive pole of the other.

The next two require each three signal wires, with three batteries, whose joint currents pass in the same direction along the common wire D.

The next six require each three signal wires only, with three

batteries. One of the signal wires, with its battery, is used as a common wire for the other two. Hence the current of the two batteries of the two signal wires unite in one, and are connected with the battery of the common wire as a compound battery.

In the following table, the first column represents the keys, which, when depressed, produce a deflection of the needles, represented in the second, third, and fourth columns, by means of their batteries, and thus closing the circuit of the wires, 1 2 3 4 5 and 6, by which the fluid is made to pass through the prepared fabric, and mark upon its space, or spaces, numbered 1 2 3 4 5 and 6, in the fifth column. In the sixth column are the letters which the marks upon the fabric are intended to represent.

Keys.	Needles.	Needles.	Needles.	Spaces on Fabric.	Letters.
H 7,	A T,	-	-	1,	A
J 7,	A S,	-	-	2,	B
K 7,	B T,	-	-	3,	C
M 7,	B S,	-	-	4,	D
O 7,	C T,	-	-	5,	E
U 7,	C S,	-	-	6,	F
H K 7,	A T,	B T,	-	1 3,	G
J M 7,	A S,	B S,	-	2 4,	H
K O 7,	B T,	C T,	-	3 5,	I
M U 7,	B S,	C S,	-	4 6,	J
H O 7,	A T,	C T,	-	1 5,	K
J U 7,	A S,	C S,	-	2 6,	L
H M,	A T,	B S,	-	1 4,	M
J K,	A S,	B T,	-	2 3,	N
K U,	B T,	C S,	-	3 6,	O
M O,	B S,	C T,	-	4 5,	P
H U,	A T,	C S,	-	1 6,	Q
J O,	A S,	C T,	-	2 5,	R
H K O 7,	A T,	B T,	C T,	1 3 5,	S
J M U 7,	A S,	B S,	C S,	2 4 6,	T
H K U,	A T,	B T,	C S,	1 3 6,	U
J M O,	A S,	B S,	C T,	2 4 5,	V
H M U,	A T,	B S,	C S,	1 4 6,	W
J K U,	A S,	B T,	C S,	2 3 6,	X
H M O,	A T,	B S,	C T,	1 4 5,	Y
J K O,	A S,	B T,	C T,	2 3 4,	Z

The patent of Mr. Davy embraces the following claims, which will be found to be very important, in regard to the

combination of electric circuits. The claims are as follows, viz. :

First. The mode of obtaining suitable metallic circuits for transmitting communications or signals by electric currents, by means of two or more wires, which I have called signal wires, communicating with a common communicating wire, and each of the signal wires having a separate battery, and, if desired, additional batteries, for giving a preponderance of electric currents through the common communicating wire, as above described.

Secondly. I claim the employment of suitably prepared fabrics for receiving marks by the action of electric currents for recording telegraphic signals, signs, or communications, whether the same be used with the apparatus above described, or otherwise.

Thirdly. I claim the mode of receiving signs or marks in rows across and lengthwise of the fabric, as herein described.

Fourthly. I claim the mode of making telegraphic signals or communications from one distant place to another, by the employment of relays of metallic circuits, brought into operation by electric currents.

Fifthly. The adapting and arranging of metallic circuits in making telegraphic communications or signals, by electric currents, in such manner, that the person making the communication shall, by electric currents and suitable apparatus, regulate or determine the place to which the signals or communications shall be conveyed.

Sixthly. I claim the mode of constructing the apparatus which I have called the escapement, whether it be applied in the manner shown, or for other purposes, where electric currents are used for communicating from one place to another.

Seventhly. I claim the mode of constructing the galvanometer herein described.

And, lastly, I claim such parts as I have herein pointed out, as being useful for other purposes, as above described.

BAIN'S PRINTING TELEGRAPH.

CHAPTER XVII.

DESCRIPTION OF THE PRINTING TELEGRAPH APPARATUS.

ON an examination of English authorities for the preparation of this work, I have been very often surprised to find the many ingenious contrivances invented by Mr. Alexander Bain. He was not a commercial man, but his inventive powers were most wonderful. He has given to the world some invaluable inventions in various departments of the sciences and arts.

As early as 1840, Mr. Bain was active in the production of a printing telegraph, of which full accounts are to be found in the various publications. I present the following as a description of his printing apparatus :

The figure overleaf exhibits the arrangements of Mr. Bain's telegraph. Imagine two figures the same, one representing the Portsmouth, and the other the London station. The same letters will refer to either instrument: *d, i* and *h* represent the signal dials, insulated from the machine. *x* is a hand or pointer. The small dots represent twelve holes in the dial, corresponding with the twelve signals, and two blanks, 1, 2, 3, 4, 5, 6, 7, 8, 9, 0. *v* is a similar hole over the starting point of the hand, *x*. *r* is a coil of wire, freely suspended on centres. *κ κ* is a compound permanent magnet placed within the coil, and immovably fixed upon the frame of the machine. *J* and *j* are sections of similar permanent magnets. *s* is a spiral spring (and there is another on the opposite side) which conveys the electric current to the wire coil, and at the same time leaves the coil free to move in obedience to the magnetic influence. So long as the electricity is passing, the wire coil continues to be deflected, but the instant the electric current is broken, the springs, *s*, bring back the coil to its *natural position*. *l* is an arm fixed to and carried by the wire coil, *n* and *r*, to stop the rotation of the machinery. *b* is a main spring barrel, acting on the train of wheels, *c, n* and *i*, which communicate motion to the governor, *w*, and the hand, *x*.

On the arbor of the wheel, *h*, is fixed a type wheel, *c*, at a little distance from the paper cylinder, *A*, on which the messages are to be imprinted. *P* is a second main spring barrel, with its train of wheels, *m*, *o*. *q* is a fly, or vane. On the arbor of the wheel, *o*, there is a crank, *v*, and the two pallets, *a* and *b*, which prevent the train of wheels from rotating, by

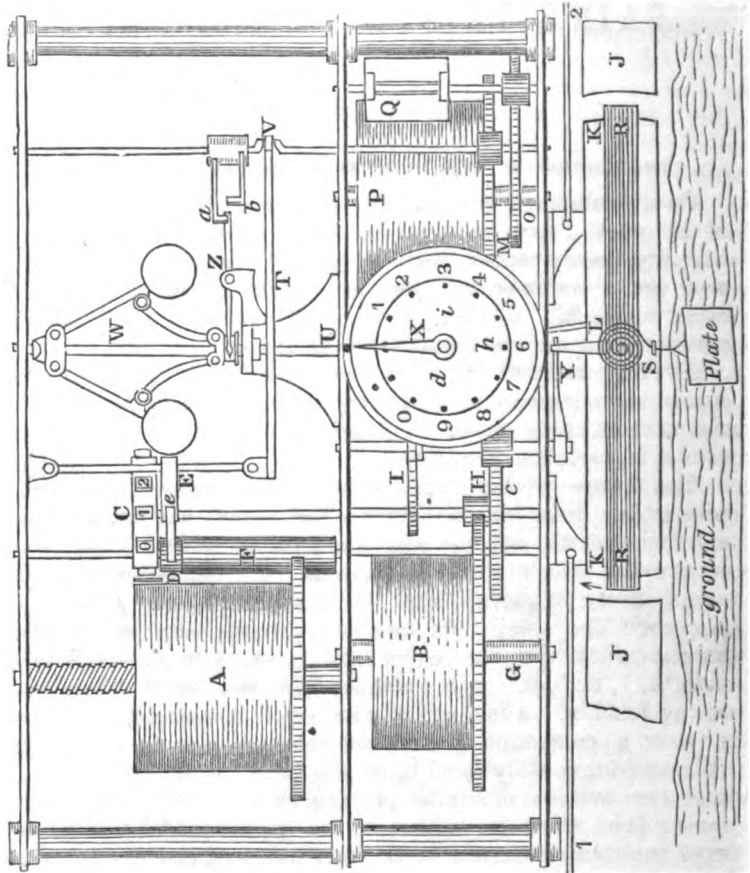

coming in contact with the lever, *z*. When the telegraph is not at work, a current of electricity is constantly passing from the Portsmouth plate, buried in the ground, through the moisture of the earth, to the plate in the ground at the London station. From the copper plate of that station the electric current passes up through the freely suspended multiplying coils, *R* and *R* (which it deflects to the horizontal position),

into the machinery, and thence to the dial, by means of a metal pin inserted in the hole, *v*; from the dial it passes by a single insulated conducting wire, *l*, suspended in the air, back to the first machine; traversing which, it passes through the freely suspended multiplied coil, *R* and *r*, which it deflects, also, to the horizontal position to the plate from which it started, and thus completes the circuit.

When a communication is to be transmitted from either end of the line (one station only being able to transmit at a time), the operator draws out the metal pin from the hole, *v*, in the dial of his machine; the electric circuit is then broken, and the ends of the multiplying coils, *R* and *r*, at both stations, are carried upward, in the direction of the arrow, by the force of the spiral springs. The arms, *L*, attached to the two coils, moving to the right, release the lever, *v*, which leaves the machinery free to rotate, and as the moving and regulating powers are the same at both places, the machines go accurately together; that is, the hands of both machines pass over similar signals at the same *instant* of time, and similar types are continually brought opposite to the printing cylinders at the same moment. An inspection of the wheel-work will show that this movement will have caused the governor, *w*, to make several revolutions, and the divergence of the balls, in obedience to centrifugal force, will have raised one end of the lever, *z*, and depressed the other, which allows the pallet, *a*, to escape; but the rotation of the arbor is still opposed by contact with the second pallet, *b*. The operator having inserted the metal pin in the hole, under the signal which he wishes to communicate, the moment the hand of the dial comes in contact with it, the circuit is again completed, and both machines are stopped instantly. The governor balls, collapsing, depress the left hand end of the lever, *z*, clear the pallet, *b*, and this allows the crank spindle, *v*, to make one revolution.

The motion of the crank by means of the crank rod, *r*, acting on the lever, *ε*, presses the type against the paper cylinder, *A*, and leaves an impress upon the paper; at the same time, a spring, *e*, attached to an arm of the lever, *ε*, takes into a tooth of the small ratchet wheel, *D*, on the spindle of the long pinion, *F*, which takes into and drives the cylinder wheel; so that the crank apparatus, going back to its former position, after impressing a letter, moves the signal cylinder forward, and presents a fresh surface to the action of the next type. As the cylinder moves round, it has also a spiral motion upward, which causes the message to be printed in a continuous spiral line until the cylinder is filled. In order to mark, in a distinct

and legible manner, the letters printed by the apparatus, two thicknesses of riband, saturated with printing ink and dyed, are supported by two rollers so as to interpose between the type wheel and the cylinder (the rollers are not shown in the figure, to prevent confusion). If a second copy of the message, thus simultaneously printed at two distinct places, is desired at either, a slip of white paper is placed between the ribands to receive the imprint at the same time as the cylinder.

Fig. 2.

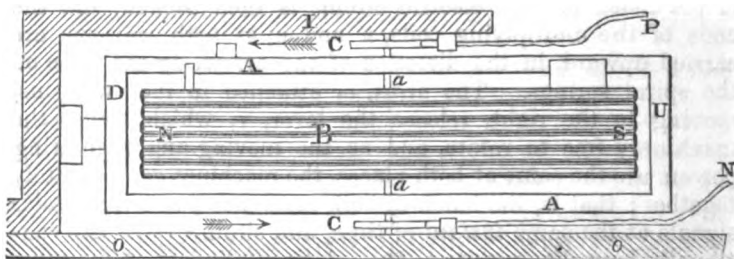

Figure 2 represents a top view of the coil and magnets of Mr. Bain's machine. *B* is the compound permanent magnet, with six bars. *N* is the north pole, and *S* the south pole. *AA* are the sides of the brass frame containing the coils; *cc* are the spiral springs on each side: *aa* is the axis of the coil: *oo* is a part of the frame containing the clock-work (not shown in this figure), supporting one centre of the coil, and *rr*, a support for the other centre. *n* and *p* are the wires, one of which is in connection with the ground, and the other with the extended wire. When the circuit is closed, and the current from *p* pole of the battery is in the direction of the arrow above, and then through the coil to the other pole, *n*, in the direction of the arrow below, the end, *D*, of the coil will be depressed, and the end, *U*, will rise; reverse the current and the effect is the elevation of the end, *D*, of the coil, and the depression of the end, *U*.

THE BRETT PRINTING TELEGRAPH.

CHAPTER XVIII.

Brett's Printing Telegraph—Description of the Composing Apparatus—The Printing Apparatus and Manipulation—The Compositor or Commutator described—Mr. Brett's Last Improvement.

BRETT'S PRINTING TELEGRAPH.

THE printing telegraph system, patented by Mr. Jacob Brett, in Great Britain, is founded upon the House system, of America, and patented by Mr. Brett, in the first place, as a communication.

These gentlemen, Messrs. Royal E. House, of America, and Jacob Brett, of England, some years since, co-operated together in this printing telegraph. The former patented the same or a similar apparatus, in the United States of America. After the issuing of the first English and American patents, Mr. House continued his energies in the perfection of his mechanism until he produced the beautiful and effective printing telegraph, since used on many lines in the United States. Like results attended the labors of Mr. Brett, except that the system perfected by him has not been permanently used on the lines in Europe. The following description of the machinery will serve to explain the instrument patented by Mr. Brett, and known in Europe as his printing telegraph.

The apparatus comprises two essential mechanisms, the "Transmitter" or "Compositor," and the "Receiver" or "Printer." I will first describe the former.

DESCRIPTION OF THE COMPOSING APPARATUS.

The compositor is a key-board, having some 28 keys, and 30 or 40 may be used, if desired, arranged as in figs. 1 and 2. Above these keys is an axis, $\Delta A'$, which is called the axis of the keys, bearing at its extremity a wheel R, called a circuit-wheel. This wheel receives a movement from a weight P, fig.

2, attached to a cord c, which is rolled around the drum B, having a toothed wheel R', which connects with a pinion P, placed upon the same axis as the wheel R₂. This wheel R₂ connects

Fig. 1.

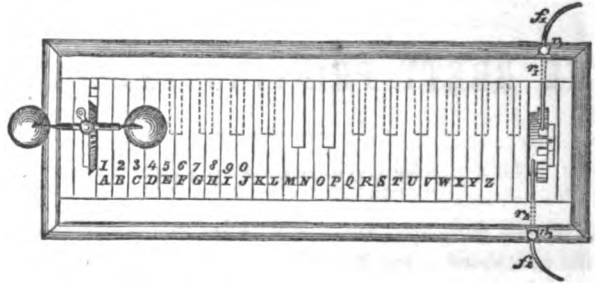

in its turn with the pinion P₁. The pinion P₁ is fixed upon the same axis as the wheel R₂, and moves wheel R₂ with its own movement; this wheel R₂, in its turn, connects with a pinion P₂, fixed to the vertical axis A, which turns with the fly-wheel v. The axis of keys A', being fastened to the wheel R₂ by a

Fig. 2.

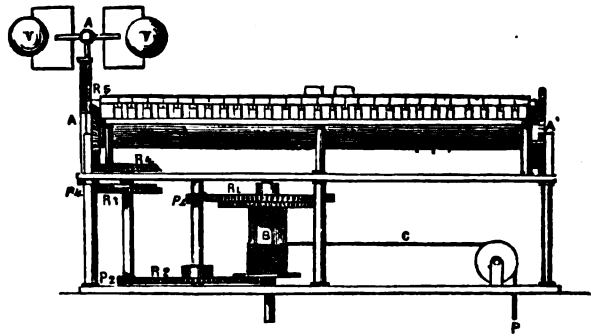

system of two wheels transmitting the movement R₄ and R₅ at right angles, turns itself under the influence of the weight p. There are fixed upon the axis of the keys 28, 30, or 40 metallic points—analogous to the pins of a music-box, or a crank organ—about a quarter of an inch high, which represent a helix on the surface of an axis, which correspond to the letters of the alphabet, figures, and other telegraphic signals. This same axis of keys, therefore, bears at its other extremity the said wheel of the circuit R, furnished with 14, 15, or 20 teeth, and which has for its object to open and shut alternately

the voltaic current, consequently to interrupt and to establish the current. One of the wires f_1 , communicates through the printing apparatus, with the conducting wire of the line; the other wire, f_2 , communicates with one pole of the battery. Two springs, $r_1 r_2$, are in metallic contact, as well as the wires $f_1 f_2$, with the two pressure screws $n_1 n_2$. The first of these springs presses upon the teeth of the wheel α , the second spring presses upon the drum of the same wheel. The fly-wheel v has for its object the regulation of the whole system of the composer, in order that the axis, after having been stopped by the lowering of one of the rods under the keys, may continue its revolution until the finger ceases to press the key. The teeth correspond exactly to the rods placed in the axis, so that when the rod of a key stops the axis, by touching against the little pins of the axis; the spring, r , touches the point of one of the teeth, and the circuit is closed.

Fig. 3.

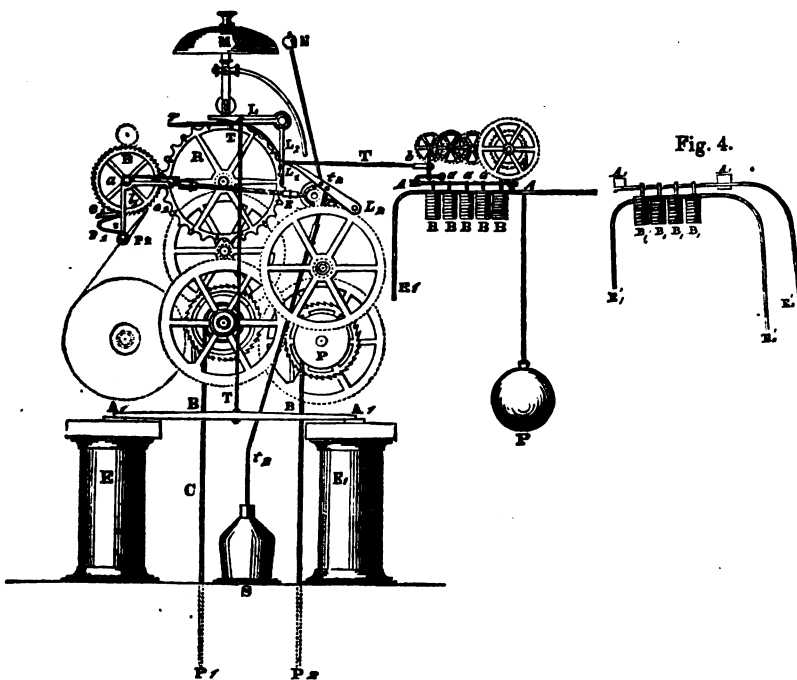

THE PRINTING APPARATUS AND MANIPULATION.

Figs. 3 and 4 represent the printing instrument, resting upon a support s . $E E_1$ are the two electro-magnets, the bar $A_1 A_1$ is

the armature ; the extremities of the wire surrounding them, are fixed to the two pressure screws inserted at the base. One of these screws receives the wire coming from the composer, and the other receives the line wire. The armatures turn on a hinge around the north pole of the electro-magnet, to which they are respectively attached, and they are united by a rectangular bar $B B$, which bears on its middle a lever-rod or arm, $\tau \tau$, which the armatures draw, when they are attracted by the electro-magnets. A spring r , borne by one of the arms of the lever $L L$, tends to elevate the rod, and to detach the armatures, when the current does not pass. The two arms of the lever $L L$, form a right angled escapement-anchor, letting pass and stopping alternately the wheel κ , of about three inches in diameter, and about one tenth of an inch thick, and furnished with 28, 30, or 40 teeth. Each of these teeth bears in relief a letter or point ; one tooth alone remains blank to form spaces. These letters, the point, and the blank space, correspond to the letters, &c. of the cylinder of the composer. This wheel κ is called a *type-wheel* ; its anterior limb bears 14 little metallic points, about one tenth of an inch long. The prolonged arms of the escapement act upon these points. When one of the arms takes hold of a point, the other lets go another point, and this effect is reproduced at each oscillation of the armature. A weight attached to the cord c tends to turn the type-wheel constantly. When the circuit closes, the axis of the keys, as well as the type-wheel, tends constantly to turn under the action of the weight. The alternate breaking and closing of the circuit, produced by the keys, causes the armature to oscillate, and the oscillations of the armature, resisted by the action of the spring r , will give to the rod τ a to-and-fro movement, which will change into an oscillatory movement the escapement anchor, and into a movement of periodical revolution of the type-wheel. The type-wheel will ordinarily make 160 revolutions in a minute, and it will stop when the rotation of the axis of the keys is stopped by the pressure of the finger upon one of the keys. The letters are printed thus: Wheel B is connected to a cylinder, upon which

cylinder is enrolled a band of narrow paper, the said cylinder turning around with its axis $a a$, resting upon two supports, $s s'$, two pendulums or cranks $b b$, terminating in two eccentrics placed upon an axis, $a a$, perpendicular to the plane of the table, turn with the axis of the paper cylinder. By the movement of

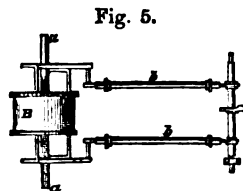

these eccentrics, fig. 5, the rotary movement of the axis

a a becomes for these cranks a to-and-fro movement, which brings the cylinder of paper near to the type-wheel, and removes it therefrom, thus bringing it in contact with and separating it from said type-wheel alternately. It is also necessary that the cylinder of the paper should turn upon its axis, in order to present at each approach a new blank part of the paper to the type-wheel. This rotation goes on by means of the reverse escapement anchor, $e_1 e$; the branch e_1 is fastened to the frame by a point p , around which it turns as around an axis; the branch e is fixed to the rod l , which is fastened to the axis a of the cylinder of the paper, and is, consequently, displaced with that cylinder. Two springs press the two branches of the anchor against the teeth of a wheel attached to the cylinder of the paper; when the cylinder withdraws from the type-wheel, the extremity e_1 , pressing against the nearest tooth, causes the cylinder to turn, and the extremity e , acting as a stop, prevents the cylinder from turning backward. At the axis, around which this rotatory movement of the cylinder takes place, is a screw, fig. 5, entering into a hollow screw placed upon the support. The cylinder is displaced in the direction of its axis, so that the printed letters form upon its surface a continuous helix, so that no two letters can produce confusion, by being placed one upon the other.

The most suitable substance for making a good impression is plumbago, reduced to a powder; it is placed in a groove or slot, out upon the circumference of the roller r , and is covered with linen. A sufficient quantity of the powder passes through the pores of the linen to ink the type.

I have not yet indicated how the axis $a a$, with its eccentrics, is made to turn; it receives its rotation from a clock movement produced by a weight p_1 . It turns incessantly, so long as nothing stops it, and each of its revolutions brings near to and removes away alternately from the type-wheel the cylinder of the paper. It is important that it should turn only when it is desirable to print, at which time the type of the letter which we wish to fix upon the paper is in contact with the cylinder. The result is obtained thus: $L_1 L_2$ is a lever fixed at its strongest extremity L_2 , upon an axis borne upon the frame of the apparatus, and around which it turns; the other extremity L_1 being bent back, presses against the posterior limb of the type-wheel, which limb is furnished with 28 points, similar to those of the anterior limb, and corresponding to the 28 letters or signs on the circumference; the bent extremity of the arm of the lever L_1 connects with the points, and rests upon them, rises with the point which bears it, leaves this point,

and falls back upon the succeeding points, &c. A metallic rod t , fixed near the extremity L_2 of the lever, communicates with an hydraulic apparatus, called a *governor*, the mechanism of which I will presently describe. The object of the "governor" is to regulate the movement of the lever $L_1 L_2$, so that it rises rapidly and descends slowly with a graduated velocity. The arm of the lever $L_1 L_2$ bears a point or horizontal rod, p' , which glides over the eccentric E , placed on the axis a , and turning with that axis. The portion of the circumference of the eccentric E , the farthest removed from the axis, is thicker, and has two notches about a quarter of an inch apart, which notches catch one after another of the points as p' , so that the eccentric stops in its rotation. Now, let the point p' rest upon the portion of the eccentric nearest to the axis, the eccentric which presents to it by turns the various points of the surface, brings to it the first notch into which it falls, stopping the movement of the eccentric. The point p' cannot get out, and will not permit the eccentric to turn, except said point p' has been raised with the lever $L_1 L_2$, by one of the points of the type-wheel. After the raising of the point p , the eccentric has turned again, and bringing to the point the second stop, the movement stops a second time, and can only recommence when the point following is disengaged from the stop, at the moment when the extremity L_1 of the arm of the lever shall leave that of the points of the type-wheel which has raised it. The point p' will then be upon the part of the eccentric nearest to the axis. It is seen by this movement that the axis a is forced to turn, when the type-wheel stops, and then by means of the cranks brings the paper into contact with the letter or sign, covered with the plumbago, which prints this letter or sign upon the paper.

The hydraulic regulator or governor is formed, first, of a glass vase v , fig. 6, filled with water, or some other liquid; second, of an internal vase, v , pierced with holes, through which the liquid may pass, and terminating by a flange, upon which the upper part of the apparatus is screwed. s is a pointed metallic valve, rising from within outward, p is a hollow piston, raised and lowered by the rod $t t$ moving in the chamber $c c'$ of the interior valve v' , leaving only a small circular space, through which the water can pass. When the piston is raised by the lever $L_1 L_2$, fig. 3, to which the rod t is attached,

Fig. 6.

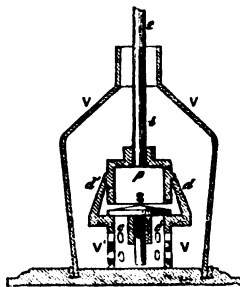

a vacuum is made in the chamber $c c'$, and the water comes suddenly and fills it; when, on the contrary, the piston descends, the water can only with difficulty escape from the chamber $d' d$, its passage consequently becomes very slow, and the movement is thus retarded, as it is required, in order that the telegraph may work perfectly.

Everything being arranged as I have just said, and the electric communication being established, if the operator of the sending station presses one of the keys with his finger, the key A , for example, the type-wheel will stop, when the same letter A arrives in front of the paper; then the lever $L L_1$, fig. 3, will turn, bring the cylinder in contact with the wheel, and press the letter against the paper, which will receive the impression of that letter. As it withdraws, the cylinder will turn upon its axis, and will present—on being brought back by the movement of the axis and of the cranks—a new white space to the new letter to be printed.

The mechanism for sounding the bell is very simple. M , fig. 3, is a bell, N is the clapper, borne upon a rod or spring fixed to the frame by an axis, around which it turns, and of which the lower part is a small lever-arm, resting upon a pin about one fifth of an inch long, when the eccentric turns, raises the little lever-arm of the spring, and causes the clapper to descend and strike the bell.

I have said nothing yet of the other portion of fig. 3. This portion represents another manner of employing the voltaic action. The rod or lever-arm T is now horizontal; it is fastened on the one part to one of the arms of the escapement, by means of a pin, upon which it works, on the other part to an eccentric placed upon a horizontal axis b' , represented with the eccentric in fig. 7. This same axis b bears a lever, e' , represented in fig. 8, and furnished with points g and g' , designed to stop the crooked parts to the right and left of b , in fig. 7. $B B B B B$, fig. 3, are hollow bobbins or spools, magnets which attract when the current traverses them; these little vertical magnets $a a$, are attached to the armature $A A$, of B, B, B, B , another but a similar system of magnets; A, A is the armature, E, E , are the extremities of the wire of the second system. When the first circuit is closed by the armature $A A$, the extremity E , is then in contact with E_1 , and the second circuit is closed in its turn. The two circuits are also opened at the same time.

Fig. 7.

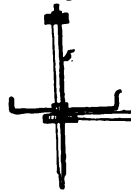
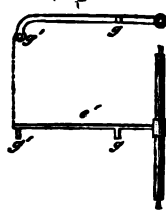

Fig. 8.



Nothing, however, prevents placing the second electro-magnet system with a local battery or electro-magnetic machine. The second system is in reality only a relay. The lever e' descends and rises with the armature, according as the circuit is closed or opened.

The axis b , in its eccentric rotation, moves away and approaches near the points g and g' , which are, by turns, in contact with the points crooked to the right and left of b , fig. 7. If the armature is attracted, the point g' is lowered, and leaves the crooked point to the left of b , fig. 7. The axis and the eccentric make a demi-revolution, and the rod r is drawn toward the left, but at the same time the point g rises, presses against the point to the right of b , and the movement is stopped; it recommences if the armature, in raising itself, lowers the point g , and disengages said point from the crooked point to the right of b , fig. 7; the axis and the eccentric will make a new half turn, and the rod r will be carried forward. The axis and the eccentric are set in motion by the weight p , by means of the system of cog-wheels represented in the drawings. When the current ceases, the armature is raised by the spring placed at k . The alternate movement of the rod r acts also upon the lever $L_1 L_2$, precisely in the same manner as in the case when that rod is vertical. Mr. Brett has greatly improved this apparatus, and has rendered the correspondence much more sure, so that by a combination of wheels, called by him "stop-wheels," the type-wheel, and the needle accompanying it, return to zero, or to the point of departure after each impression of a letter.

The new compositor is represented by figs. 9 and 10: Λ , fig. 10, is the axis of the pins in communication with the keys and circuit wheel, N ; I is a friction wheel or moveable cylinder fastened to the lever arm, J . The axis of this lever has its centre of rotation on the axis of the tooth wheel, H , and of the pinion, P . The wheel, H , transmits its movement to the wheel, F , having the same number of teeth, so that when the part P Q Λ , of the frame fig. 9, is depressed by the pressure on one

Fig. 9.

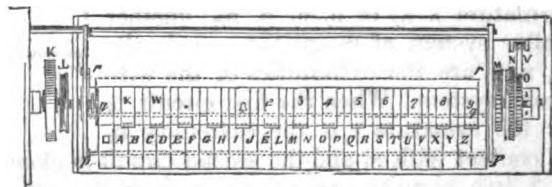

of the keys, the rod, τ , disengages the friction wheel, κ , at the same time the tooth wheel, H , causes the wheel, F , to move. The two friction wheels, I κ , turn, moving the axis of the keys A , together with the circuit wheel, M , and the catch wheel, o . The pinion, G , bears a fly wheel, i i , which regulates the velocity of the machinery. A weight attached to a cord which is enrolled upon the cylinder, B , communicates the movement to the wheels, E and F , to the pinion, G , and to the wheel, C , together with the catch wheel, D . Another weight, p , attached to a cord, rolled around the pulley, L , brings the axis, A , borne by the gudgeons, t t , to its first position, when it has turned, after the friction wheels are disengaged. The number of teeth of the circuit wheel, N , is equal to half the number of the letters or signals. It turns upon the same hollow axis, with the stop wheel, o . A point projecting from the circuit wheel acts upon a second stop wheel, M , which latter wheel has its centre

Fig. 10.

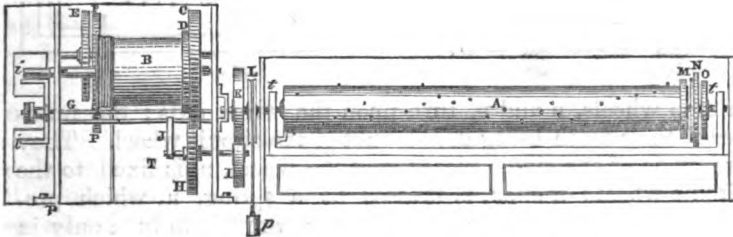

upon the axis of the keys, A . When this axis turns with the friction wheels, I κ , it moves the wheel N ; but when the friction wheels are disengaged, and the axis, A , turns upon itself, moving the friction wheel, M , the circuit wheel, N , together with the wheel, o , is stopped by the click, v , fig. 9, so that this circuit wheel turns in one direction only, notwithstanding the to-and-fro movement of the axis, A . If, therefore, we lower one of the keys, and with it the bars p q , fig. 9, by the means of the lever arm, these bars, in lowering, raise the upper part of the frame and the axis, τ , turns a rod attached to one of the extremities of τ , raises the lever, J , and with it H and I , the friction wheel, κ , is set at liberty; the axis, A , turns until it is stopped by the pin of the key cylinder, corresponding to the key which has been lowered. If you cease to press, the lower part of the frame rises, the pin ceases to stop the key cylinder, the action of the weight, p , makes itself felt, the cylinder returns to its primitive position, but the click, v , still acting, the stop wheel, o , keeps the type wheel, N , in the posi-

tion to which it has arrived. The type wheel will make a new movement forward if you lower another key.

THE COMPOSITOR OR COMMUTATOR DESCRIBED.

Figs. 11 and 12 represent the compositor or commutator, finally adopted by Mr. Brett. The axis, *A*, bears a circuit wheel, *c*, fig. 12, the number of teeth of which equals half the number of letters or signals of the telegraph. Two catch

Fig. 11.

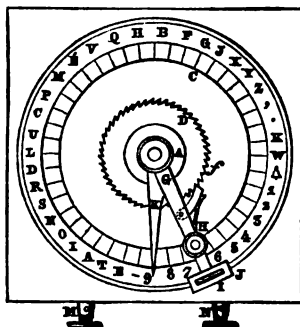
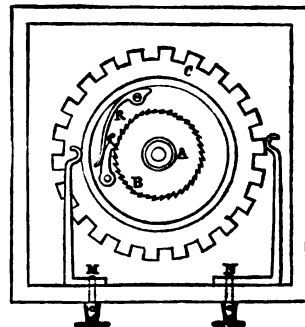

Fig. 12.



or stop wheels, *B* and *D*, turn upon the same axis; the number of their teeth being double that of the circuit wheel. They are made of one single piece; and the wheel, *B*, is fixed to the circuit wheel; a click, *e*, pressed by a spring, *R*, which prevents it from turning backward, and permits it to turn only in one direction. The axis, *A*, fig. 11, also bears a lever arm or crank, *GHI*, with an indicator, *K*, which points upon the dial to the letter which we wish to transmit or print. A click, *F*, also pressed by a spring, catches into a stop wheel, *D*, and serves to make it turn toward the right at the same time with the crank, the stop wheel, *C*, and the circuit wheel, *D*; but when the crank is moved to the left, in order to bring the index, *K*, upon a letter, the click slides over the teeth of the wheel, *D*, which remains at rest; thus the click, *e*, fig. 12, prevents the wheel *B*, and the circuit wheel from turning. Two copper bands or springs, *MN*, press, one upon the exterior part of the circuit wheel, and the other upon the teeth of the circumference of the same wheel, and communicate by means of two pressure screws with the two poles of the battery of the conducting wires of the circuit. The roller, *I*, fixed at the extremity of the crank, *H*, serves for the better guiding and maintaining it in its rotary movement. A stop pin, *J*, renders it fixed when the indicator, *K*, arrives at the desired letter. The

movement of the apparatus is as follows : Turning the crank to left, brings the indicator, *k*, upon the letter to be printed at a distance ; then turning the orank to the right in order to come back to the fixed starting point, the circuit wheel is caused to turn, which establishes and breaks the circuit as many times as is necessary, in order that the type wheel may present to the paper the particular letter marked by the indicator.

MR. BRETT'S LAST IMPROVEMENT.

Fig. 13 represents the new form given by Mr. Brett to his printing telegraph. The weights are replaced by a spring,

Fig. 13.

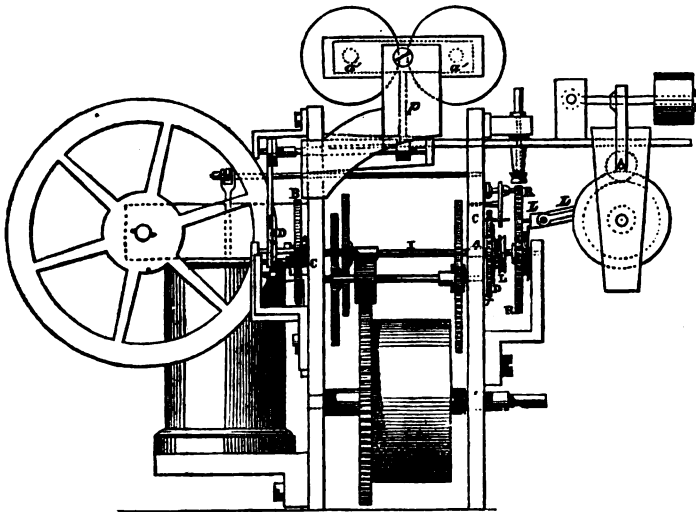

two systems of common wheels gives motion to the type-wheel, and communicates the movement to the paper. The type wheel, *R*, is moved by the pinion, *A*, and the arbor, *r*, and its rotation is regulated by the electric escapement represented in fig 14. The pinion, *A*, communicates with a toothed wheel, *B*, furnished with a second pinion, *C*, placed upon the same arbor as the escapement wheel, *D*. This escapement wheel is by turns stopped and released by an escapement anchor, *a*, of which the axis bears a permanent magnet, *p*, serving as an armature to the electro magnet, *a'*. According as the electric current traverses in one direction or another the wire of the electro-magnet, the armature is attracted or repelled ; this alternative movement is transmitted, first to the anchor, then to the escape-

ment wheel, then to the arbor of the pinion, *A*, and finally to the type-wheel, which moves regularly step by step.

The type-wheel, *R*, is fixed upon a hollow axis, *A*, and this axis bears on one side a little toothed wheel, applied against the face of the type-wheel; on the other side a fixed pulley, *L*, upon which is coiled a cord bearing a weight, the action of which constantly brings back the type-wheel to the starting point, or zero. A new toothed wheel is fixed to this pulley, and a circular metallic disk is fixed to the arbor, *r*, bearing a click which engages with the teeth of a little toothed wheel, and prevents it from turning back. A toothed wheel, *R*, of larger

Fig. 14.

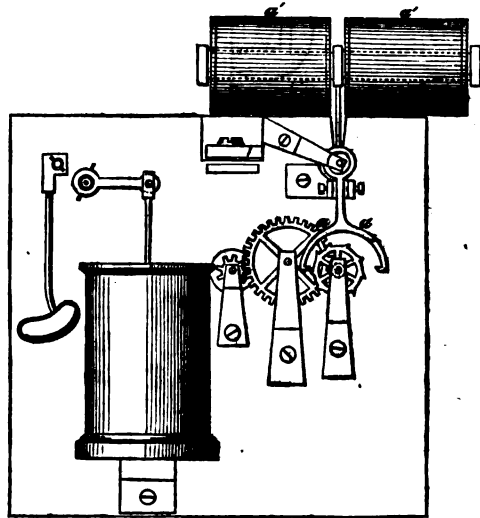

diameter, is also fixed upon the same axis, *r*, so that it may turn for a certain time, and then turn backward, in order to lower the prolongation of the disk, *D*, bearing a point which engages in a little opening made on the circumference of the toothed wheel, *r*, very near its rim; this toothed wheel is set in motion by the action of the extremity of a lever operating by means of an eccentric, as has been explained in the description of the first machine or apparatus. Now if one of the letters, or one of the characters of the type-wheel, has been brought before the paper, a lever similar to *L*₁ *L*₂, fig. 3, engages in the opening made in the stop wheel that presses against the type wheel. This lever causes the said stop wheel to turn, and with

it the eccentric already described, which puts in motion the whole train of wheels of the printing machinery, and in its turn, during its revolution, presses a piston against the paper, and the letter is printed. While the paper advances after the printing of the letter, sufficient to make room for the next letter, another lever presses again upon the teeth of the wheel, *r*, giving it a rotary movement, sufficient to disengage the click of the disk, *d*. The type wheel being set at liberty, returns to zero, and resumes its first position upon the arbor, *i*. You may now proceed to print another letter.

The arbor of the lever, has a second arm fastened by means of a rod, to an hydraulic and pneumatic piston, similar to that which has been represented in the figure, and which serves to render the impression of the character perfect, regular, and neat.

Mr. Brett calls attention to the disposition given by him to the letters upon the disk of the type wheel, this disposition being very necessary to abridge the labor in the transmission of dispatches; in fact, the letter *e*, for example, in the English language, and still more so in the German, occurs three thousand times, while the letter *z* appears but once.

I hope the foregoing description will enable the reader to understand the intricate mechanism of this apparatus. The drawings and the lettering are not as perfect as I had hoped to attain. The letters mentioned in the description are not all to be found in the drawings, and in this imperfect state I present the apparatus with its novelty.

THE MAGNETO-ELECTRIC TELEGRAPH.

CHAPTER XIX.

Application of Magneto-Electricity to Telegraphing—Its Advantages—Description of Henley's Apparatus—The Brights' Apparatus—Its Comparative Celerity.

APPLICATION OF MAGNETO-ELECTRICITY TO TELEGRAPHING.

THE magneto-electric telegraph is a needle system. It is practically employed on the lines of the Magnetic Company in Great Britain. The Messrs. Bright having tried magneto-electricity, most faithfully, on the lines of their company for several years past, commend it as of superior utility. They informed me, that a pair of magnets, costing at Sheffield 30s., and perhaps 40s. to 45s. according to finish, will send a strong current on a well-insulated pole line for 200 miles, and on an underground wire above 100 miles. Weak signals had been received on 250 miles underground wires, while on the same lines, a battery of six twelve-cells, was necessary to perform the work, at a cost of £7, 10s., besides the cost of renewals.

A magnet, if the keepers are put on when the instrument is not in use, will retain its magnetism for an indefinite time. They had worked magnets two and three years without remagnetizing them. The experiments made with magneto-electricity by these gentlemen, establish the practicability of its application to telegraphing; in this, however, there is a difference of opinion among scientific telegraphers. Mr. Bakewell, in his late work on electricity, asserts, that electricity generated in this manner is small in quantity, and of comparatively great intensity, therefore more liable to be diverted from this circuit by imperfect insulation; and as another objection to this form of telegraph, he states, that the needle sends signals in one direction only. Two communicating wires are consequently required to obtain the same combination of deflections that can be given with a single wire, when a voltaic current is

transmitted. The great advantage, however, of this system is, that it dispenses with the use of voltaic batteries, which are troublesome and expensive; but it remains a question to be determined by practical experience, whether this advantage is sufficient to counterbalance the objections attending the use of magneto-electricity.

The Magnetic Company have several thousand miles of wires, on all of which this system is used, and the brothers Bright, who have been engaged in that company's service for some six years, concur in the opinion of its superiority over the voltaic telegraphs.

It would be unjust, not to fairly consider the opinions of such experts as have expressed their admiration or approval of magneto-electricity for telegraphic purposes. In America, but few trials have been made on the telegraph lines to use this species of electricity, but of these trials reference will be found elsewhere in this book. On the continent of Europe, there are no lines employing it. In Great Britain, it has only been successfully used on the Magnetic Company's lines, as hereinbefore stated. Without further comment, I will give

Fig. 1.

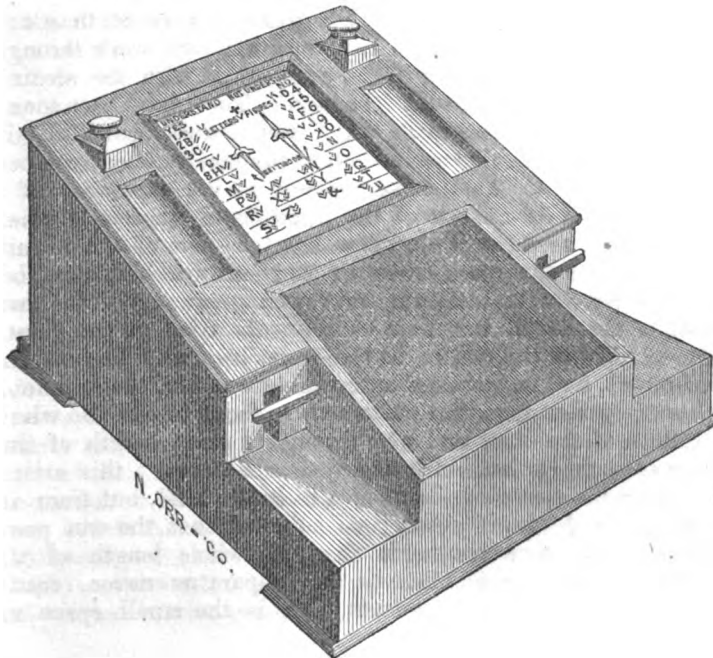

its advantages, and a description of the apparatus as furnished me by Mr. Henley, one of the inventors.

Fig. 1 is a representation of Mr. Henley's instrument, as used in the office for telegraphic service. Before giving a description of this very simple apparatus, I will present the advantages claimed for it by the inventor, which are as follows:

ADVANTAGES OF MAGNETIC OVER VOLTAIC ELECTRICITY.

1st. Capability of working without expense, except first cost.
2d. Being always ready for instant use, however long it may have remained inactive.

3d. From its simple construction (being entirely free from all clockwork or complicated movements, and also from all apparatus found in other telegraphs for cutting off or reversing the electric current), it cannot get out of order.

4th. The magnetic needle used for the indications being freely suspended on a vertical axis, without springs or weight of any kind to keep it in the neutral position, and being subjected to the energetic action of an electro-magnet instead of wire coils, moves with a much less electric force than any other telegraph whatever; it, therefore, follows, from the well-known fact of the great diminution of the power of the current in passing through long conductors, that this telegraph will work at a greater distance, or through a greater resistance, than any other, the distance at which any telegraph will work through a given sized wire being in an exact ratio with the electric force required to work such telegraph. There have been many ingenious contrivances made which would work beautifully in a room, but are totally useless when practically tried between distant stations. Another severe test of the capability of a telegraph is a damp state of the atmosphere, especially when the earth is used (as it always is now) as part of the circuit. Every supporting post, when its earthenware insulators become covered with moisture, conveys a great part of the current to the earth, but from experiments tried on the South Devon railway (known to be the worst insulated line in the kingdom), and in the most unfavorable weather, the magneto-electric current from this machine was found to pass the whole distance of the line, and also through a great length of fine wire at each station, without any loss whatever; this arises, not from the electricity being of a different kind, but from its quantity and intensity being so adjusted that the wet posts should offer more resistance than the whole length of the metallic wire. In addition to this apparatus never requiring renewal, a very important fact is the small space re-

quired; the magneto-electric telegraph, 18 inches long by 4 inches wide, will transmit a current much farther than twelve 24-cell batteries, occupying a space of $19\frac{1}{2}$ square feet.

Fig. 2.

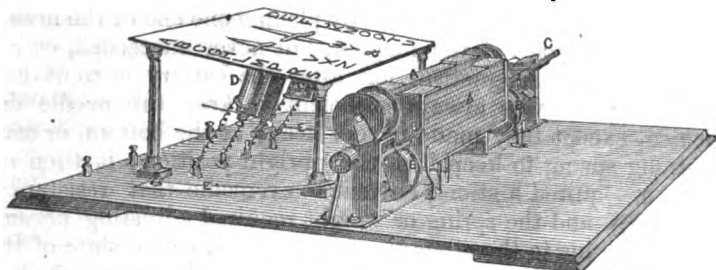

DESCRIPTION OF HENLEY'S APPARATUS.

Each instrument has two parts, one for producing the current and transmitting it in the required direction, and the other for receiving it from a distant station. The first consists of two compound permanent bar magnets *A A*, about 10 inches long, placed in a horizontal position parallel with each other, about an inch apart; at each end is suspended, on separate axles, a soft iron armature, on the cylinders of which are wound long coils of fine copper wire covered with cotton, *B B*. Each pair of coils forming one armature, is connected by one end of the wire of each coil—the other end of each is carried through the axle (but insulated from it) to the base in two spirals. The wires pass under the base, one end of each goes to the electromagnet of its own dial, and thence to the line and through the distant instrument until it communicates with the earth; the other is led direct to the earth, connections being made by the terminals at the back of the instrument. The other armature and its connections are just the same, and answer the same purpose with the other side of the dial. The armatures are moved by levers, *c c*, the ends of which pass through the outer case for the convenience of working; their motion is limited by India-rubber stops fixed on the brass casting on which the magnets are placed and the axles suspended. The ends of the magnets are covered with soft iron caps projecting inward so as to bring the poles within about half an inch of each other; these soft iron poles increase the power of the magnets greatly, besides which they will condense the whole power of the magnet at any particular point. The second or receiving part of the instrument consists of a dial mounted on four

pillars in an inclined position, this being the best for reading the indications, besides reducing the friction of the needle pivots to one twentieth part. Under the dial two electro-magnets, *D D* are fixed, one for each needle. It may be mentioned, that electro-magnets have been attempted to be used before for deflecting the needle, by placing one end of the needle between the poles of the magnet, but never succeeded, owing to the residual magnetism left after the battery current had ceased. This was always sufficient to keep the needle deflected, except they made it very heavy at the bottom, or used a strong spring to keep it in the upright position; it then re-

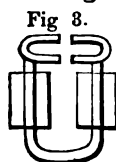

quired a strong current to overcome that resistance, and the spring or weight required adjusting according to the strength of the battery, or the state of the weather. In the magneto-electric telegraph two pieces of soft iron are placed on the poles of the electro-magnet of a semicircular shape, which thus forms four poles. (See fig. 3.) Within these is suspended a magnetic needle, the axis of which is prolonged through the dial, carrying an index or pointer. This, as well as the magnetic needle, is limited in its motion by stops on the dial.

Fig. 4.

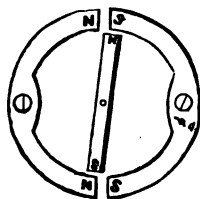
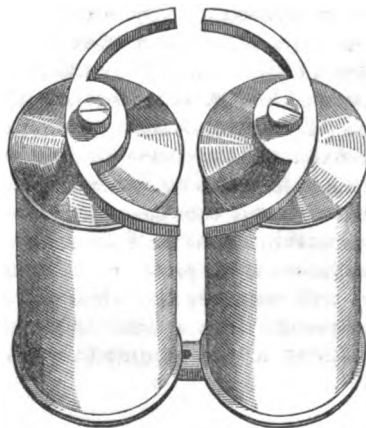

Fig. 5.



Figs. 4 and 5 represent the magnetic needle, and the horns of the magnet. On pressing down the lever, the ends of the armature change place with respect to the poles of the magnet. This produces a current of electricity in the armature, and through the circuit, which, passing round the wire on the electro-magnet, causes it to become magnetic. As shown in the diagram, fig. 4, there are then

four distinct forces acting on the needle to deflect it in the position shown; the two south poles of the electro magnet attracting one end of the needle, and repelling the other, and the two north poles the same with the other end. While the handle is kept down, although no electricity is passing, the needle is kept deflected by the residual magnetism in the horns. On allowing the lever to return by the force of the spring on the base, the ends of the armatures and magnets again change places,

and a current of electricity is produced in the opposite direction, which entirely neutralizes the residual magnetism, and then reverses the poles of the electro-magnet, bringing the needle to the opposite side; but in the single-needle telegraph, the armature takes a midway position between the poles, which has the effect of neutralizing the residual magnetism only. Fig. 5 represents the electro-magnets, with the horns attached.

In the ordinary needle telegraph, a diamond-shaped needle is suspended within coils of wire. (See fig. 6.) On the passing of an electric current the needle has a tendency to move at right angles to the wire. When a flash of lightning strikes the wires, the needle cannot move quickly enough, but the poles move, that is to say, the polarity of the needle is placed at right angles to its former position; consequently, on the passing of the battery current, it has a tendency to remain stationary; in this way 200 or 300 miles of telegraph are rendered inoperative in a single night. On inspecting the magneto-electric telegraph, it will be obvious this cannot occur—the lightning in passing through the instrument will not act primarily on the needle, but secondarily by the electro-magnet; this becoming magnetic will deflect the needle if the current is passed in one direction, and if in the other will have a tendency to retain it in its ordinary position; and if any change occurs, it would be by the needle becoming stronger. Should the telegraph remain a long time out of action, the horns of the electro-magnet form keepers to the needle, and maintain its power; and, likewise, by the arrangement of armatures and permanent bar magnets, the latter will always retain their power; the poles are brought so near together, that the armature before leaving one magnet is on the other. This arrangement gives three advantages: the magnets always have the protection of a soft iron keeper, and the two currents produced by leaving one magnet and approaching the other, are combined in one, doubling the strength and duration of the current; and it is evident, if the magnets were farther apart, when the armature was quite free of both poles, it would alter the magnetic character of the other armature, and thus produce a current in it, and move the wrong needle.



The signals are indicated on the dial by the separate or combined motions of the two needles, for instance, A, B, and C, are separately indicated by one, two, and three motions of the left needle; D, E, and F, by similar motions of the right needle; G, one left and one right; H, one left and two right; I, K, by the reversed motions of the needles; for the remainder of the letters, the simultaneous motions of both needles are used

in addition to one or more of either needle ; marks are placed on the dial near each letter, to indicate what motions are required for it ; two marks meeting at the bottom like the letter v, signifies the simultaneous motion of both needles.

DESCRIPTION OF THE BRIGHTS' APPARATUS.

The Magnetic Telegraph Company, under the able administration of the distinguished telegraph electricians, the brothers Bright, have on its lines an instrument operated by magneto-electricity, invented by those gentlemen. In principle it is the needle telegraph, worked by the inductive influence exercised by magnets upon electro-magnetic coils, when placed in propinquity to the poles of the permanent magnets. Fig. 7 represents this apparatus.

Fig. 7.

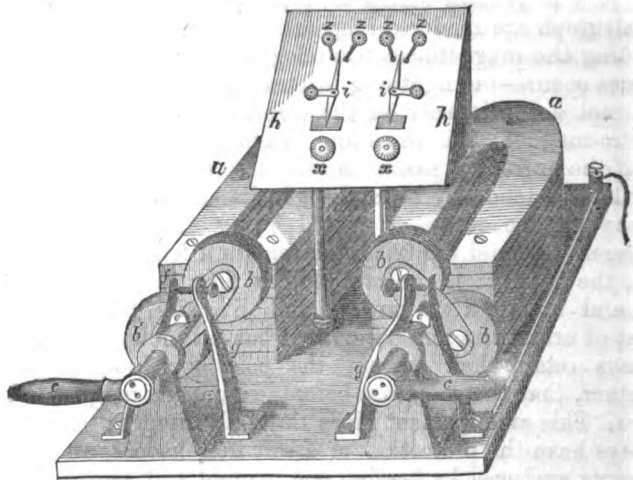

This instrument is placed upon an ordinary table, before which the operator sits ; letters *a a* represent the compound horseshoe magnets, formed of steel, and screwed to *g*. Those which I have frequently seen in England and Scotland, in the offices of this company, have magnets about 15 inches from the poles to the back or bend, about 5 inches in height, made of 12 plates, and in breadth about $1\frac{1}{2}$ inches ; *b b* and *b' b'* are induction coils attached to the axles moved by the handles *c c*. The operator placing his hands on *c c*, by depressing and elevating them, a current of electricity is generated. One of the wires terminating each pair of the inductive coils, is connected to an insulated *cam* ; the other end of each pair of coils is con-

ducted directly to the earth: *c c*, the metallic *cams*, are insulated from the axles to which they are attached by ivory plates; *ff* are two springs connected with the line wires, and resting against the screws of the bearings *g g*, which are bridge pieces, in connection with the indicating portion of the instrument: *h h* is the outside of the dial plate, and *i i* are the indicating needles moved by the magnetic needles inside on the same axles; *x x* are thumb screws, by which the regulators are adjusted; *z z z z* are adjusting pins between which the needles beat.

The internal arrangement is much the same as given in the description of Mr. Henley's machine, and, in fact, fig. 5. is a drawing of an electro-magnet given me by the brothers Bright, on one of my visits to Liverpool.

The spring *f*, when at rest, is in contact with the bridge piece *g*, and the line wire is in direct communication with the indicating dial face. The electric or magnetic current from other stations of the line pass from the line wire through the indicating coils, and thence to the earth, which on passing through the coils produces the desired indication, or movement of the needles. When the handle is depressed, then the metallic "cam" attached to the axle presses upon the spring, and moves it away from the bearing *g*, at which time the current of magneto-electricity produced in the induction coils, by the changing of their position, as regards the pole of the permanent magnet, passes to the line wire, and this movement deflects the needle from "zero" at other stations.

When the depressing motion of the handle ceases, and it begins to ascend, a different current is induced, which also flows through the line wire, bringing the needles of the other stations back to zero, from which they had been taken as just above described; but at the same time the apparatus of the operating station is not changed, because the connection between the spring *f* and the bearing *g*, remain incomplete. When the spring *f* is brought into contact with the bridge piece *g*, on the cam *c*, which sets it at liberty, the line wire, in which a portion of the lost current has been fixed, as in transmission, seeks to gain its equilibrium, and the recoil current passes through the indicating part of the apparatus, and holds the needle at zero, in the proper position to be actuated by currents from the other stations.

ITS CELERITY COMPARED WITH OTHER NEEDLE SYSTEMS.

In the arrangement of the dial of this apparatus, the brothers Bright have improved its operation by placing the adjust-

ing pins z , between which the needles vibrate. In other needle systems, the needles move to the right or to the left with unequal force, and on their restoration to zero, they swing beyond as a pendulum, causing error or delay in transmission by the waiting for the needle to rest at zero. These pins not only aid in celerity of communication, but they produce a sound. The needles beat against the pins, and a sound is produced sufficiently distinct to be read by the operator. In practical telegraphing, therefore, these pins prove very great auxiliaries in communicating dispatches. The operator need not depend upon the eye to see the movement of the needles. The pins may be made to produce different sounds, and those sounds can be as distinct as the beats or movements of other systems producing intelligible sounds.

The brothers Bright informed me that they found in practice the apparatus as arranged by them much more reliable than the needle system not having the stop pins. The movement of the needles, and their *dead beat*, that is, the absence of all vibration and oscillation, tended to prevent mistakes. In the ordinary galvanic needle systems, which have not the stop pins, the needles sway to and fro, after each beat, occasioning more or less confusion between letters, which are formed by the combination of "*beats*." Such are the advantages claimed for the magneto-electric telegraphs.

HIGHTONS' ELECTRIC TELEGRAPHS.

CHAPTER XX.

High Tension Electric Telegraph—Gold Leaf Instruments—Single and Double Pointer Needle Apparatus—Revolving Pointer—Improvements in Batteries and Insulation.

HIGH TENSION ELECTRIC TELEGRAPH.

THE telegraphs invented and patented in Great Britain by the Rev. H. Highton and Mr. Edward Highton, though not in practical use as a whole at the present time, were evidently decided improvements on their introduction. Mr. Edward Highton had been for many years a telegraph engineer, and he had given evidences of a thorough knowledge of the intricacies of this mysterious science and art. In giving those improvements, I will present the descriptions made by Mr. Edward Highton, and also his opinion as to their advantages over other telegraphs of that day.

The first patent was taken out in 1844 by the Rev. H. Highton. In this telegraph electricity of high tension was employed, viz., that produced either from the ordinary electric machine, or from the hydro-electric machine: one wire only was used. A piece of paper, which was moved uniformly by clock-work mechanism, was conducted at the receiving station between two points of metal in connection with the line-wire, the points being placed one *above* the other, and on *opposite* sides of the paper. On sending currents of electricity, the paper was pierced by the electricity, every shock making a little hole through it. If the electricity transmitted were positive, a hole was pierced at *one* of those points, and if negative, a hole was made at the *other* point. By the combination of these perforations letters and symbols were denoted.

By an arrangement of these dots or holes, under the ordinary mathematical law, from 30 successive currents of electricity, occupying, say, 15 seconds of time, no less than 1,073,741,824 different signals could be made.

Extract from the Specification of the Patent granted to Henry Highton, for Improvements in Electric Telegraphs. Sealed February 8, 1846.

“ In the electric telegraphs now commonly used on English railways, signals are given by the motions of magnetic needles, which are caused to move to either side by the action of electric currents passed in either direction through coils of wire surrounding magnetic needles. And I have discovered that signals can be exhibited in electric telegraphs by motions produced by electric currents in strips of metallic leaf, suitably placed, in a very cheap form of signal apparatus, resembling a gold-leaf galvanometer.

Fig. 1.

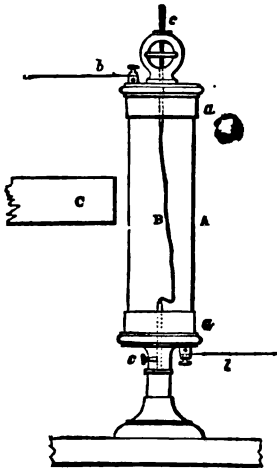

“ The drawing hereunto annexed represents a signal apparatus, consisting of a glass tube, A, fitted in brass caps, a, a, at top and bottom, and having a strip of metallic leaf, B (gold leaf being the kind of metallic leaf which I usually employ), passing through its centre, loosely

hung, in metallic contact with the said caps; the upper extremity of the metallic leaf being fixed at right angles to its lower end, so that the metallic leaf, from whatever direction seen, will present at some part its flat surface to the eye. The caps, a, a, (which are moveable, in order that the metallic leaf may be replaced, if broken,) are placed in a circuit suitable for electro-telegraphic communication.

“ Near to the metallic leaf (as on the outside of the glass) is placed either of the poles of a magnet c. And the effects of this arrangement is, that when a current of voltaic electricity is caused to pass through the circuit, and, therefore, also through the metallic leaf, B, included in it, the metallic leaf is deflected to one side or the other, according to the direction of the current. And the distinct motions so obtained may be repeated and combined, and used for the purpose of designating letters or figures, or other conventional signals.

“ One of the above-mentioned signal apparatuses is placed at each terminus of telegraphic communication, and others may be placed at intermediate points.

“ Each terminus, and also each intermediate station, is provided with a voltaic battery, and with one of the key-boards in use in single magnetic-needle electric telegraphs. The person in charge of the telegraph at either terminus, or at any inter-

mediate station, produces the requisite connections for causing an electric current to pass in either direction through the circuit, and, therefore, through the metallic leaf of the signal ap-

Fig. 2.

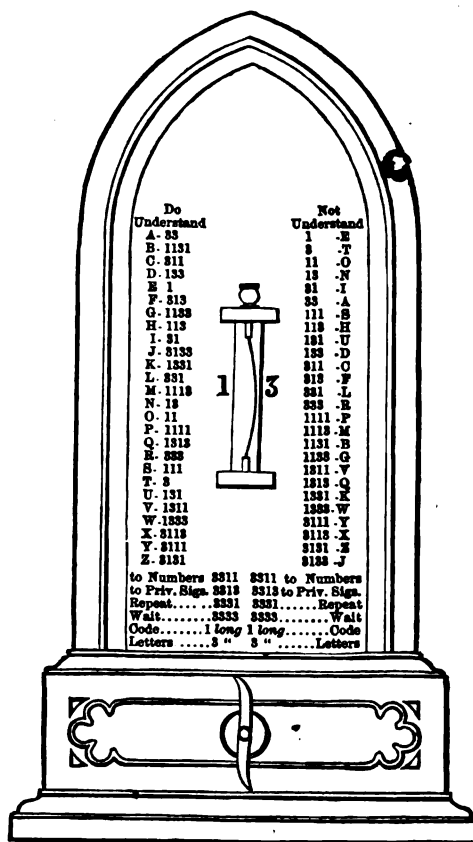

Gold-leaf Telegraph for one line-wire, with code-table shown on dial.

paratus of each terminal or intermediate station, and thus cause the metallic leaf of all the signal apparatuses to move simultaneously to either side, so as to give the required signal or signals.

“The key-board of each terminal or intermediate station has a handle, by moving which, the person in charge of the telegraph at any station can cause an electric current to pass through a circuit, in connection with a system of alarms at the terminal and intermediate stations, similar to those in use in magnetic-needle electric telegraphs.”

The next patent was taken out in January, 1848, by Messrs. H. and E. Highton.

At this time Mr. Edward Highton was acting as telegraphic engineer to the London and Northwestern Railway Company, and was pressed by that company to invent a set of electric telegraphs free from the objections and defects inherent to most telegraphs then in use, and free also from any of the then existing patents.

Every telegraph proposed or executed at that time, was minutely investigated, and their defects studied with the greatest care. Neither time nor money was spared to accomplish the objects desired. The result was a series of inventions of great variety and extent.

For these inventions, the patentees received from the hands of His Royal Highness Prince Albert, as President of the Society of Arts, the greatest honor the society had the power to bestow, viz., their Large Gold Medal.

Several of the plans were immediately adopted on the London and Northwestern Railway, in preference to those of the old Electric Telegraph Company, who then possessed a great number of patents. The telegraphs gave the greatest satisfaction, and have been in constant daily use ever since.

The principal feature of the inventions in this patent were, viz.:

The horseshoe magnet was suited to coils, and was thought to be much superior to the old straight magnetic needle and coil of Cooke and Wheatstone. In step-by-step motion telegraphs, a means was provided for causing the pointer or disk at once to progress by one bound to zero on the starting point.

The maximum work capable of being produced by any number of lines was taken advantage of, and thus three wires were made to produce 26 *primary signals*, and so to show instantly any desired letter of the alphabet. Under Ampère's plan, 26 wires must have been used, and under Cooke and Wheatstone's patent, 6 wires. Suitable keys were devised for sending currents of electricity over three wires in the 26 orders of variation.

Direct-action printing telegraphs were devised, so that a single touch of one out of 26 keys caused instantly any desired one out of 26 letters or symbols to be printed.

The insulation of wires was improved, and many other improvements relating to electric telegraphs effected.

The advantage of the horseshoe magnet over the straight magnet or magnetic needle of Professor Wheatstone was thus stated by Mr. Highton: When a coil surrounds a straight magnetic needle, as used by Messrs. Cooke and Wheatstone, *each* convolution of the wire has to pass *twice* over the central or *dead part* of the magnet; whereas, if the horse-shoe magnet

be employed, there is *wire only* where there is magnetism in the magnet to be acted on. This latter arrangement, therefore, enables all superfluous resistance in the circuit to be dispensed with; and hence the same amount of electric power is enabled to produce a far greater effect on the distant telegraphic instruments, or *less* power to produce an *equal* effect. Currents of electricity from secondary batteries were to be employed where great mechanical effects were desired at the distant station. An instrument was devised for this purpose, called a "perænode."

The next patent was taken out by Mr. Edward Highton on the 7th February, 1850.

Fig. 3.

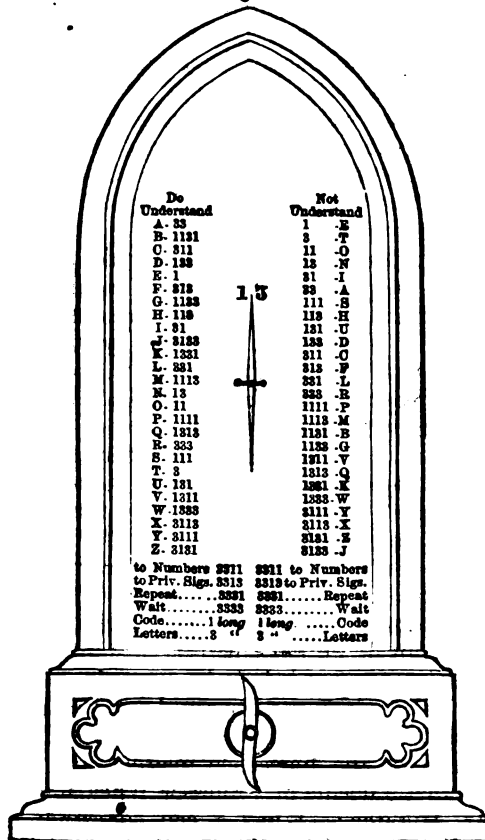

Single-pointer telegraph for one line-wire, with code shown on dial. The pointer is moved to the right or left by the horseshoe magnet and coil.

SINGLE, DOUBLE, AND REVOLVING POINTER TELEGRAPHS.

The patent contains a great many improvements in different classes of telegraphs. A few only of the principal features will be alluded to here.

The first part refers to modes of arranging electric circuits. Means of employing electricity of different degrees of tension,

Fig. 4.

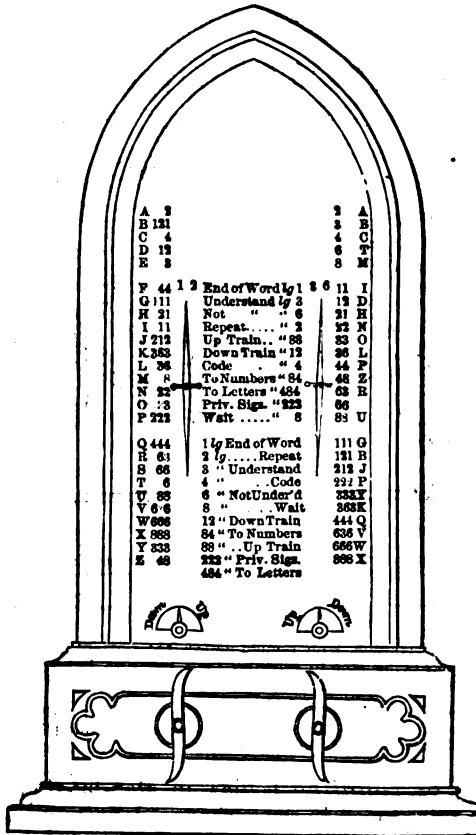

Double-pointer Telegraph for two line-wires, with code-table.

and of different periods of duration, are also shown, so that two kinds of electric apparatus may be connected to *one* line-wire, and one only worked, as desired. By this means one of the wires usually employed was rendered unnecessary. Other improvements relating to the dials are also made

A new mode of causing motion in soft iron. by temporarily

magnetizing it by the contiguity of a powerful magnet, is described, which promises to be of great value in electric telegraphs, as by the employment of this apparatus any demagnetization of the magnets in thunder-storms is entirely obviated, and the coils of wire are made to give out more power.

Fig. 5.

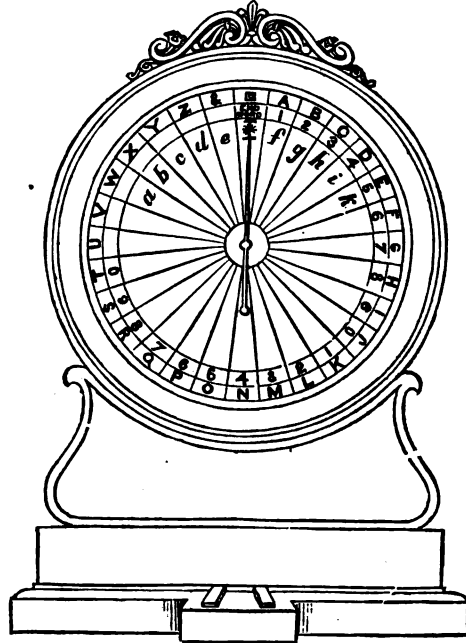

Revolving-Pointer Telegraph, with double action escapement, for either one or two line-wires, the pointer being able to progress from letter to letter, or to pass by one bound from any letter the whole distance up to zero.

The letters in the rays are substituted for the following, viz.: a—Numbers; b—Private Signals; c—Code; d—Letters; e—End of Message: end of the word; f—Repeat; g—Understand; h—Wait; i—Not understand; k—Go on.

Pendulous, or vibrating bodies, in step-by-step motion telegraphs, are introduced in order that a definite period of time may elapse between each successive current of electricity; and these same bodies are caused to make and break the circuit, so that no second current can be transmitted till all the instruments in a series have completed the word due to the prior current. In this way, all overrunning or lagging behind of one instrument, as before described, is entirely obviated.

Besides these improvements, Messrs. Highton made many others, in batteries, construction of lines, and in the administra-

tion of telegraph affairs. They invented a revolving disk telegraph, with a new double-action escapement for either one or two line-wires ; also, a direct letter-showing telegraph for three line-wires, in which the instrument produced the desired letters instantly into view in the centre of the dial by means of three movable screws ; and, also, a printing telegraph, suited for either one, two, or three line wires, according to the rapidity of transmission desired. In this telegraph the letters were printed by one touch of a key, when three wires were used.

IMPROVEMENT IN BATTERIES AND INSULATION.

Their improvement in batteries, which requires not the slightest attention for months together, many of which were employed in doing the most severe work on the London and North-western Railway, were not touched for periods of three, four, and even twelve months at a time, and yet they gave out, whenever required, a constant and equable flow of the electric power. This was accomplished by the substitution of a solution of the sulphates of the earths instead of sulphuric acid. These gentlemen invented an improvement, relating to the manner of protecting and using insulated submarine or subterranean telegraphic wires. It consisted in surrounding the insulated wires or strands of wire, by putting them in the middle of a wire-rope, so that the insulated wires may be surrounded with a flexible covering of iron, or galvanized iron or brass, or other hard wire, or small rods of such materials. This patent was dated September 21, 1850.

BAKEWELL'S ELECTRIC COPYING TELEGRAPH.

CHAPTER XXI.

**Manipulation of the Electric Copying Telegraph of F. C. Bakewell of England—
The Apparatus Described—Secrecy of Correspondence, its Advantages and
Disadvantages.**

MANIPULATION OF THE COPYING TELEGRAPH.

THERE have been many plans proposed for transmitting intelligence by electricity, and producing, at a given destination, a fac-simile of the writing presented at the sending station. The following seems to be the most practicable yet devised, and the inventor, Mr. F. C. Bakewell, of England, is confident that it will accomplish the great desideratum on lines of any length.

The copying telegraph transmits copies of the handwriting of correspondents. The advantages of this mode of transmission are, that the communications may be authenticated by the recognized signatures of the parties by whom they are sent, and as the writing received is traced from the original message, there can be no errors of transmission; for every letter and mark made with the pen is transferred exactly to the other instrument, however distant.

The electro-chemical mode of marking the paper, invented by Mr. Davy, is adopted in the copying process. The writing is copied on paper soaked in a solution of prussiate of potash and muriatic acid, a piece of steel wire serving for the pen. The paper is placed round a cylinder about six inches in diameter, and a steel wire, connected with the copper end of the voltaic battery, presses upon it, and is carried slowly along by a screw as the cylinder revolves. By this arrangement, when the voltaic current passes uninterruptedly from the wire through the paper to the cylinder which is connected with the zinc end of the battery, lines are drawn upon it at the same distance apart as the threads of the screw that carry the point. These

lines are in fact but one continuous spiral line, commencing at one end of the cylinder and ending at the other.

The communication to be transmitted is written on tin-foil, with a pen dipped in varnish. Thin sealing-wax varnish, made by dissolving sealing-wax in spirits of wine, answers the purpose best, as it dries very quickly. The letters thus written form on the conducting metal surface a number of non-conducting marks, sufficient to interrupt the electric current, though the deposit of resinous matter is so slight as not to be perceptible by the touch.

The message on tin-foil is fixed round a cylinder at the transmitting instrument, which instrument is a counterpart in its mechanical arrangements of the receiving one, and either of them may be used to transmit and receive messages. A metal style in connection with the voltaic battery presses on the tin-foil, and it is carried along by an endless screw as the cylinder revolves, exactly in the same manner as the steel wire that draws lines on the paper on the receiving instrument. The varnish writing, when it interposes between the style and the tin-foil, stops the electric current; consequently, at every part where the electric current is stopped by the varnish at one instrument, the steel wire ceases to make marks on the paper at the other station. Both instruments are so regulated that the cylinders rotate exactly together, therefore the successive breaks of the electric current by the varnish-letters cause corresponding gaps to be made in the lines on the paper; and the succession of these lines, with their successive gaps where the letters occur, produces on the paper of the receiving instrument the exact forms of the letters. The letters appear of a white or pale color on a ground of blue lines, there being about nine or ten lines drawn by the wire to make one line of writing. In the diagram, A shows the writing on tin-foil, from which the copy is made in the form shown at B.

Fig. 1.



It is essential to the correct working of the instruments that the cylinders should rotate exactly together. This synchronous movement of the two instruments is effected by means of regulating electro-magnets, aided by a "guide-line" on the transmitting cylinder.

The moving power of each instrument is gravity, accelerated motion being prevented by a rapidly revolving fan, which produces a very steady movement of the cylinder. The speed may thus be very easily varied by adding or by taking off weight. The "guide-line" consists simply of a strip of paper pasted across the tin-foil at a right angle, as shown at c. That strip of paper effectually stops the electric current, and leaves a gap of equal breadth in each line drawn on the prepared paper of the receiving instrument. If the receiving instrument be moving at exactly the same speed as the transmitting one, these gaps in each line will be in the same relative positions, and will fall under each other on the receiving cylinder, making a broad white stripe corresponding with the strip of paper on the transmitting cylinder. But if the receiving cylinder be moving faster than the other, the gaps in the lines will not fall under one another, but every one will be farther toward the right hand. By noticing the position of these gaps on the paper, it may be seen exactly how much faster one instrument is going than the other, and weight may be taken off the receiving instrument until the gaps form a continuous stripe. In this manner the two instruments may be regulated to move together. It is immaterial at what distance apart they are; for if they be in the same room, or two hundred miles from each other, the same plan of adjustment must be adopted.

Supposing the mechanism of the instruments to be very good, and that there were no irregularities on the surfaces of the cylinders, the plan of regulating by means of the guide-line alone would be sufficient for the copying process. Legible writing may, indeed, be obtained in that manner, but not with sufficient accuracy and certainty to be depended on in ordinary working operations. To secure the requisite degree of accuracy and certainty, an electro-magnetic regulator is used. This may be brought into action by means of a second communicating wire, or by local action altogether; in the latter case a single wire only is required to work the copying telegraph. When two wires are employed, one of them is used for the electro-magnet that regulates the instruments, the other for transmitting the current that marks the paper by electro-chemical decomposition. The diagram will assist in explaining the mode

of regulating the instruments when a separate wire is used for that purpose.

THE APPARATUS DESCRIBED.

Fig. 2.

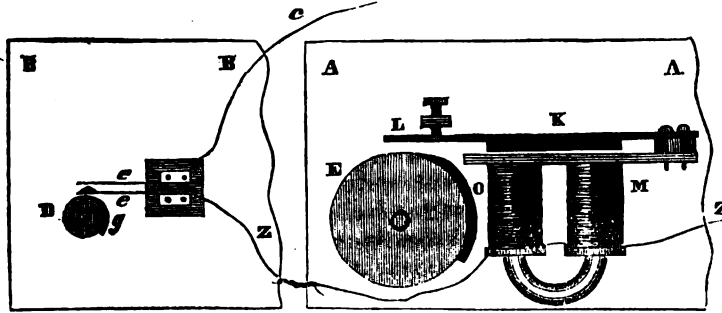

A side view only of the two instruments is given, without their stands or other mechanism than that which appears on the outside of each; the trains of wheels propelled by the weights being contained within the cheeks *A A* and *B B*, and the cylinders being on the opposite sides. The wheel *D* is fixed to the projecting arbor of a fast-moving wheel next to the fan, and it makes twelve revolutions to one of the cylinder. Two springs *e e*, insulated from the instruments by being mounted on wood, are connected by wires *c z* to the voltaic battery, and to the electro-magnet *M* on the other instrument. The other end of the coil of wire round the electro-magnet is fixed to the voltaic battery, so that when the two springs *e e* touch, the circuit of the battery is completed, and the electro-magnet is instantly brought into action. This occurs once every revolution of the wheel *D*, by the projecting part *g* pressing the two springs together. The wheel *E* on the instrument *A* is fixed on to the arbor of a wheel corresponding with that of *D*, and likewise makes twelve revolutions to one revolution of the cylinder.

The keeper *K* of the electro-magnet has an arm or lever *L* added to it, which reaches to the circumference of the wheel *E*, and, when the keeper is attracted by the magnet, rubs against a projecting part of the circumference *O*, and thus operates as a break to check the motion of the instrument. In regulating the instruments to rotate synchronously by these means, a heavier weight is put on *A* than on *B*, to cause it to rotate considerably faster than the other when the break is not applied. But when both instruments are set in motion, the lever being pulled down each time that the springs are pressed together by

the wheel *D*, the break is thus put in operation just sufficiently to make the movements of the two instruments correspond. By this arrangement, it will be observed that one instrument regulates the other; and it has it under such complete control that if the speed of *B* be diminished, the movement of *A* will be retarded by the longer continued action of the break, and be made to rotate equally slowly, and even to stop by stopping the motion of *B*.

When the instruments are worked at a distance from each other, the electro-magnet *M* is put into action by a local battery, and the contact is made and broken by an intermediate small electro-magnet, as in Mr. Morse's telegraph. In that manner the copying telegraph has transmitted messages with perfect accuracy from Brighton to London.

When a single communicating wire only is used, the instruments are regulated independently of each other by means of pendulums. Clock-movements, with pendulums that beat four times in a second, are employed at each instrument. These pendulums at every vibration strike against springs, at each contact with which the electro-magnets which regulate the instruments are brought into action.

The arrangement of the mode of making and breaking contact by the pendulum will be easily understood by the diagram.

Fig. 8.

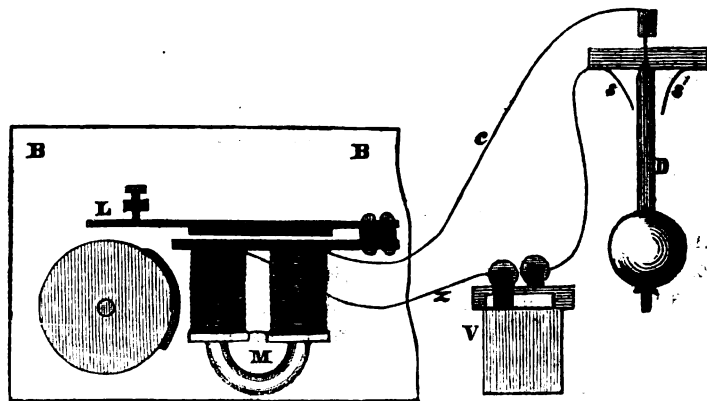

The pendulum *D* is connected by the wire *c* to the electro-magnet *M*. The springs *s s'* are connected with the voltaic battery *v*, from which a wire *z* connects with the other end of the coil of the electro-magnet. It will be evident, therefore, that when the rod of the pendulum vibrates against *s s'*, the voltaic circuit is completed through the magnet, which is

brought into action in regulating the instruments as rapidly as the pendulum beats.

The guide-line serves to indicate with the greatest accuracy whether the pendulums at two corresponding stations are beating together; for if one be vibrating faster than the other, the guide-line on the paper will be slanting instead of perpendicular; and by means of an adjusting screw to raise or lower the pendulum-bob, the two may be readily adjusted to beat together. In this manner a variation of even the thousandth part of a second may be observed and corrected.

It may probably be supposed, because the metal style has to pass over each line of writing nine or ten times to complete it, that the copying process must be necessarily slow; but it is, on the contrary, very rapid. A cylinder six inches in diameter will hold a length of paper on which one hundred letters of the alphabet may be written in a line. The cylinder revolves thirty times in a minute; and allowing ten revolutions to complete each line of writing, the rate of transmission is three hundred letters in a minute. Much greater speed than that has been obtained.

SECRETY OF CORRESPONDENCE.

One of the advantages which the copying process also possesses is the means it affords of maintaining the secrecy of correspondence. It is now customary for those who wish their communications not to be known to transmit messages in cipher, by which certain letters or figures have significations given to them which are only intelligible to the parties corresponding. This plan has the disadvantage of being liable to error, as the clerks are ignorant of the meaning of the symbols they transmit. By the copying telegraph the symbols made on the tin-foil are transmitted as accurately as if written in full, for no manipulation whatever is required, the effect being produced altogether by mechanism.

There is also a special mode of maintaining secrecy by transmitting the messages impressed on the paper invisibly. If the paper be moistened with diluted acid alone, the iron is deposited on the paper, but no mark whatever is visible, and the paper remains blank until it is brushed over with a solution of prussiate of potash, which instantly renders it legible. In this manner messages written with colorless varnish may be transmitted without any one seeing the contents; that part containing the name and address being alone rendered legible till the message is delivered to the person for whom it is intended.

NOTT'S ELECTRIC TELEGRAPH

CHAPTER XXII.

ELECTRIC DIAL TELEGRAPH.

On the 20th of January, 1846, Mr. John Nott, of England, took out a patent for a particular description of an electric telegraph.

Fig. 1.

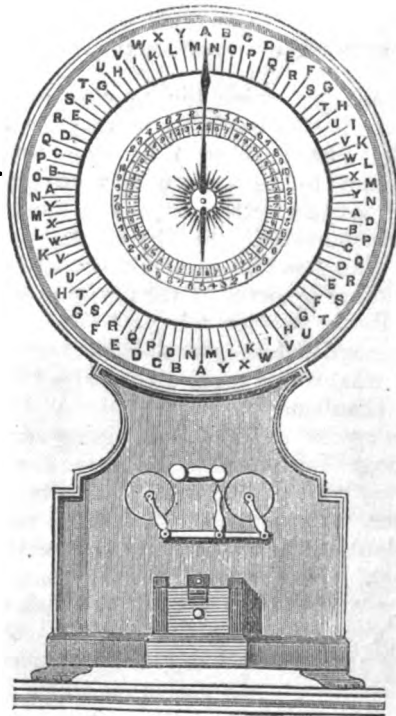

In this instrument, an electro-magnet causes an armature to catch into the teeth of a wheel, so as to force it forward one tooth on the sending of each current of electricity.

By the sending of currents of electricity at small intervals of time, the wheel, and pointer attached to it, may thus be worked to any desired points on the dial. Letters were engraved on the dial as seen in fig. 1. There are duplicate sets of the alphabet, to produce the greater celerity. Any letter might be pointed out by the hand being allowed to rest at such letter for a short period of time.

INTERIOR MECHANISM OF THE APPARATUS.

Fig. 2

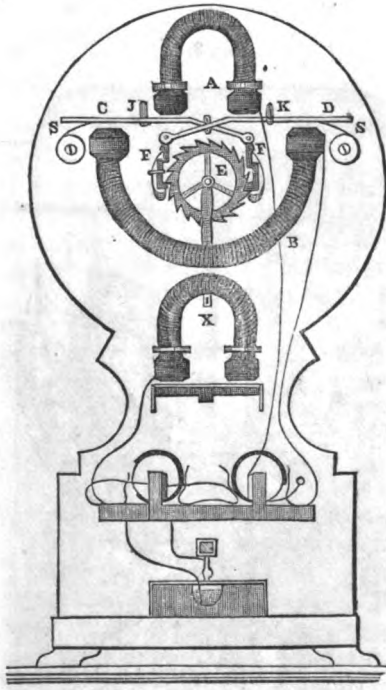

The interior view of the telegraph will be seen in fig. 2 Letters A and B are electro-magnets, with armatures c and d working on centres j k ; E is a ratchet-wheel in which armatures F and F work. In this ratchet-wheel the hand shown on the dial in fig. 1 is attached. As the armatures c and d are

attracted to the electro-magnet A and B, the wheel E moves forward one tooth, and the hand progresses from one letter to the next. A similar movement occurs when the current ceases, the armatures being forced back by the springs s and s. In this way the hand may be brought successively opposite to any desired letter. x is an electro-magnet for sounding the alarm before a communication is made.

Mr. Highton states that this telegraph was bought by the Electric Telegraph Company and never employed except to a limited extent.

I have presented this apparatus to the consideration of the reader, because it embraces combinations similar to a more recent invention proposed in America, and for the purpose of giving information on every improvement calculated to promote the art of telegraphing.

Fig. 8.



SEIMENS AND HALSKIE'S GERMANIC TELEGRAPH.

CHAPTER XXIII.

Description of the Telegraph Apparatus—The Alarm Bell—Electric Circuits and Manipulation—The Transmitter and its Application.

DESCRIPTION OF THE TELEGRAPH APPARATUS.

THIS apparatus is organized upon the principles of the dial-pate system, and is universally admitted to be the most perfect in the European telegraphic service. The following description, though very defective, will give the reader a knowledge of its mechanism and manipulation. I have seen this apparatus on the German railways; it was really a model of beauty, and to me very simple. It serves the purposes of rapid communication; it is easy to keep in order, and it is susceptible of manipulation by the ordinary employés of the railway service. In the organization and finish of the apparatus, and in the perfection of the system, Messrs. Seimens and Halskie have exhibited rare powers, fully sustaining the distinguished and enviable reputation enjoyed by those gentlemen in Europe, as telegraphers.

In fig. 1, $E E_1$ are the poles of an electro-magnet, perpendicular to the upper side of the box, or the plane of the drawing, flat on one side and round on the other. $A A_1$ is the armature, something like a reversed ω , moveable around a vertical axis, which axis is supported by two gudgeons fixed on the support c ; a lever-arm is fixed to the middle of the armature, and the spring R draws it continually upward toward the left, tending to separate the armature from the electro-magnet, so that it will not be in contact with it, except when under the influence of the attraction produced by the passage of the current, and so that the armature will separate therefrom, under the traction of the spring, when the current is interrupted. The fig.

ure shows how, by means of the screw v , and of its adjustment, the spring R_1 can be stretched more or less, and increase or diminish the facility with which the armature detaches

Fig. 1

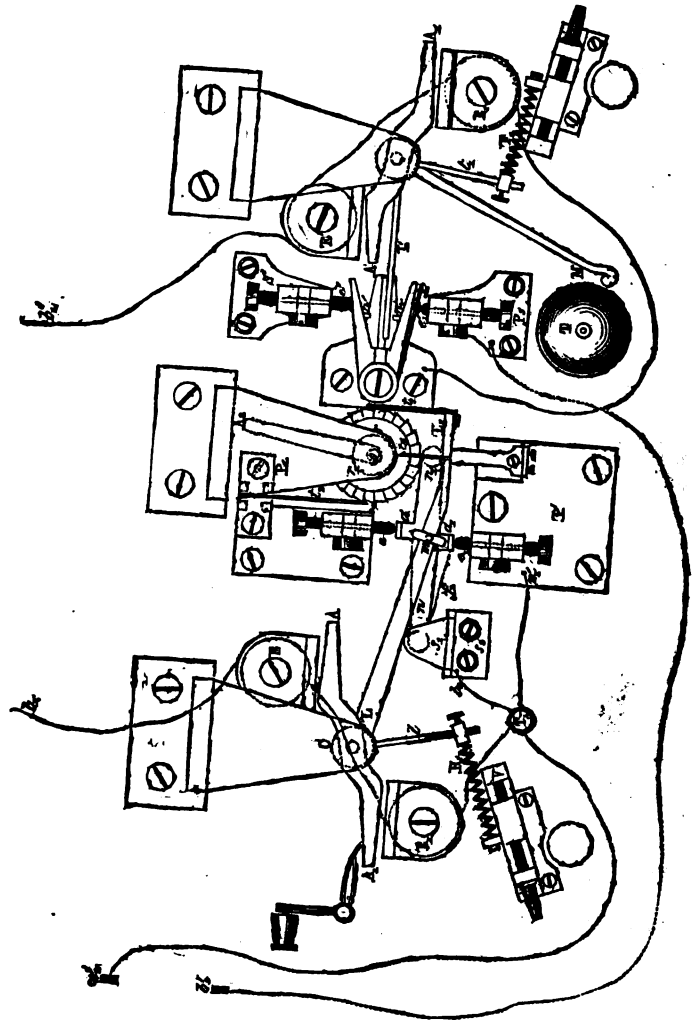

itself from the electro-magnet. A long lever branch, L, L_1 is also fixed to the armature, and turns with it on the same axis, and shares with it in the movement. This lever bears at its

extremity L_1 , a rod with a hook t_1 , which engages in the teeth of a little steel-toothed wheel r ; the ratchet in descending makes this wheel turn one tooth; when rising, on the contrary, it slides upon the inclined plane of the succeeding tooth, and engages itself above it, in order to make it descend in its turn. A second hook, t_2 , borne by the plate P_1 , prevents the toothed wheel from turning back during the ascending movement of the rod t_1 ; a steel needle or indicator o , fig. 1, and o_1 , fig. 3, borne by the axis of the toothed wheel r_1 , turns with it upon the circular dial of the keys, fig. 3, and passes successively before the telegraphic letters or signals written or printed on the keys of fig. 2. It will be seen, therefore, that whenever the current is interrupted, the lever l detaches the armature, and makes it descend; the hook-rod L_1 , t_1 lowers a tooth, makes the indicator advance one step, and brings it from one letter to a succeeding letter. The most essential part of this instrument has been called, by Messrs. Seimens and Halskie, the

Fig. 2.

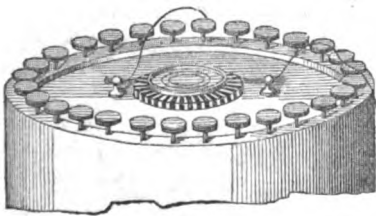
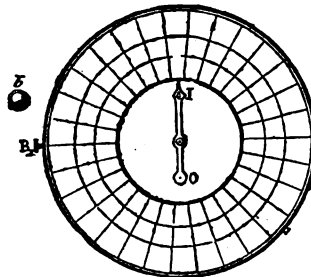

Fig. 3.



“shuttle,” because it is similar in effect to a weaver’s shuttle, moving continually from right to left, and from left to right, closing and opening the circuit, and giving also to the armature a continuous movement. The shuttle $n n$, scarcely perceptible in the drawing, is thus composed; upon the support s_2 , is raised a little brass column, bearing on its upper part the little, elongated, rectangle $n n$, of copper, furnished with two right-angled appendages, with sockets $a a_1$, and very easily moved; this is the “shuttle.”

At each of the extremities of the appendages $a a_1$, and perpendicular to the surface of the shuttle, is fixed a little piece of copper, pointed upward, and represented by the dotted lines on the faces $n n_1$. Underneath the extremity n_1 , is a little foot, which has a to-and-fro movement, with the shuttle around the centre n_1 , and rests at the bottom upon a little projecting metallic band. The shuttle, consequently, oscillates horizon-

tally exactly at the middle of the lever-arm $L L_1$; its foot at n_1 rubs, in the least degree possible, upon the band which supports it; and, in order that the shuttle may be completely insulated from the metallic plate P_1 , this foot is covered at its lower extremity with an agate stone. The movement of the shuttle, always quite circumscribed, is limited by the screws e_1 , and these screws are borne by two uprights, fixed to the plates $P_1 P'$, and, their heads being rounded, they fit into the cavities of the metallic appendages a_1 ; by means of these screws, the movement of the shuttle $n n_1$ can be regulated. When the appendage a_1 touches the screw e_1 , the appendage a is at a small distance from the screw e , and reciprocally; a wire spring, slightly stretched at f_1 , fixed to the shuttle itself, and which is shown by the dotted lines in the figure, tends to keep the appendage a_1 constantly in contact with e_1 , and prevents the little jars and oscillations of the shuttle from ever occasioning a momentary separation of a_1 and e_1 . It is then the appendage a_1 and the screw e_1 , which establishes the metallic contact necessary for the closing of the circuit. The only function of a and e is to circumscribe the movement of the shuttle. The nut m is connected in the movement of the lever $L L_1$, and presses, alternately, sometimes upon a , and sometimes upon a_1 ; but as it is a trifle shorter than the distance between a and a_1 , it cannot move between a and a_1 without taking the shuttle with it in its movement. In the figure, m presses against a_1 , if the lever-arm moves from the side of a_1 , the shuttle will, at first, remain immovable, but a moment before the hook t_1 engages above the following tooth, the nut m presses against a , and at that instant it displaces the shuttle; there is then no longer communication between a_1 and e_1 ; a is then in non-metallic contact with e_1 . The shuttle remains in this position until the armature, dropping down, makes the nut m press against a , and re-establishes the metallic contact between a_1 and e_1 , by separating a from e ; it will be seen that the extent of the movement of the lever-arm $L L_1$ is much greater than that of the shuttle, and that it is only at the moment that the lever has arrived at its maximum, right or left point of separation, that the shuttle makes a very small movement, first to the one side and then to the other.

One of the ends b_1 of the wire of the electro magnet connects with a pressure screw, the other end of the wire traverses the hole τ_1 , and connects at b , with the support s_1 of the shuttle; another wire is screwed to the plate P_1 , and has metallic communication with e_1 , which also traverses the hole τ_1 , and is fixed to a pressure screw. If, then, b_1 and a' , are united to

the two poles of the battery, the circuit through the apparatus will be closed as long as a_1 touches e , and will be opened when a touches e .

In the position represented by the figure, the current coming from the positive pole of the battery to b_1 , traverses the wire of the electro-magnet, comes to b_2 , passes from b_2 into the shuttle, comes from the shuttle at a to a'_1 , and goes to the negative pole through a'_1 . The armature is attracted, the hook t_1 is placed above the next tooth, but at the same time the nut m presses a , and makes the shuttle advance toward e_1 , the contact no longer exists between a_1 and e , the circuit is broken, the current is interrupted, the armature separates from the electro-magnet, the hook t_1 descends, taking with it a tooth, and making the indicator advance a step upon the dial; at the moment when this return movement attains its limit, the nut m presses against a_1 , and a_1 against e_1 , the current is again closed, and everything recommences.

In order to prevent the shock of the lever-arm against e from causing two teeth to pass, instead of one, or causing the hook not to pass over a single tooth, there is fixed:

1st. Upon each of the teeth of the wheel r_1 a steel feather, ratchet, or bevel edge, as indicated in the figure by the white rays.

2d. Upon the lever-arm $L L_1$ is a little vertical steel rod, indicated by t_2 at its extremity, and it is bent toward the bottom every time that t_1 engages in the space between the two succeeding teeth, and stops the wheel r , the bent extremity t_2 abandons the ratchet teeth, which are directed downward; but every time the lever-arm redescends, and sets the wheel r_1 in motion, t_2 places itself between two consecutive ratchets, makes the left ratchet pass, opposing the passage of the right-hand ratchet; in this manner, a movement of the lever-arm $L L_1$ toward e_1 can never let two teeth pass, and the needle of the indicator must always pass freely from the centre of one signal to the centre of the following signal. One of the principal characteristics of this telegraph is, that as long as the battery is in the circuit, the mechanism operates, and the needle of the indicator passes constantly over the dial without intervention of any clockwork.

I will now notice the means by which the movement is stopped to indicate any letter. A circular key-board, fig. 2, forms a sort of a gallery around the apparatus, each key bears a letter, or signal, and is prolonged with a steel point, which, when pressed by the finger on the key, is caused to penetrate into the apparatus. The axis of the wheel r , which bears the indicator, carries with it a second needle Δ_2 , situated under

the plate P_1 . Each key pressed down, becomes an insurmountable obstacle to the rotation of the needle, the wheel stops, and with it the indicator of the dial, as well as the lever-arm $L L_1$.

It will be seen, by the preceding, that, at the moment when the letter indicator attains the middle of a space, the lever-arm $L L_1$ goes toward e_1 , the hook t_1 places itself in the interval of the two succeeding teeth. If, then, the indicator is to be placed before a letter, the lever-arm $L L_1$ must be stopped in its return toward e , before the nut m arrives in contact with a_1 , and also before the indicator has reached the middle of the space at which it ought to stop. For that purpose, the needle A_1 is prolonged and inclined, so that it presses against the rod, sunk by the lowering of the key, before the nut m touches a_1 , and before the indicator on the dial has reached the signal at which it ought to stop. If the finger is taken off the key, the rod rises, the needle A_1 is no longer stopped, the spring detaches the armature, the nut m presses against a_1 , a_1 arrives in contact with e_1 , the current circulates again, and the armature recommences its oscillations.

THE ALARUM BELL APPARATUS.

The alarum bell is represented, in part, by fig. 4. It is composed of a new electro-magnet, as seen in fig. 1, $E' E'_1$, having also its armature in the form of an ∞ reversed. $A' A'_1$, moveable around an axis; this axis bears the lever-arm L' , which

Fig. 4.

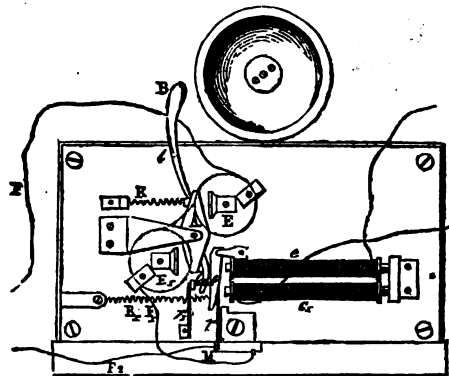

partakes of the to-and-fro movement of the armature. A metallic plate, P_3 , serves as a support to a little foot, upon which a shuttle $n' n'_1$ rests, its form being different from that of

the telegraph apparatus. It has a prong of a fork, moving within very narrow limits, between the two screw heads $e' e_1$. Each interior jaw of the shuttle bears, near its middle, two little insulating bone or ivory buttons, against which the lever arm l' strikes in its oscillations, making the shuttle $n' n_1$ move in its turn, sometimes toward e' and sometimes toward e_1 ; the jaw n_1 bears a very elastic spring, with an insulating piece, and which, by its pressure, prevents the oscillations of the shuttle from ever separating a_1 from e_1 . A spiral spring r_1 , which can be stretched or loosened at pleasure, and which draws upon the lever-arm l_1 fixed to the axis of the armature, tends to detach the armature from the electro-magnet, and even to detach it after the current has ceased to pass. This same axis bears a long, round-headed bar, which strikes upon the bell τ as often as the armature is attracted.

The screw-poles $e' e_1$ (of which the first is insulated from the support s' , while e_1 is in constant metallic contact with the opposite) must be adjusted and regulated for the intensity of the current and the tension of the spring. It will be seen that the bell apparatus is analogous to the telegraph apparatus. The entire mechanism is contained in a round brass box, fig. 3, some twelve inches in diameter, and upon the top of which is the circular key-board, the letter-dial, and the indicator. Two square screw heads are seen to project on the sides, which enables the operator to regulate, by means of a key, and without opening the box, the springs of $e_1 e'$; another screw-button, B_1 , serves to act directly on the escapement, and to bring the indicator upon such letter or signal as we desire. The letters $s e$ and n are written twice over, on account of their very frequent occurrence in the German language. Above and below are two vacant spaces, upon which the indicator is brought at the end of each word.

THE ELECTRIC CIRCUITS AND MANIPULATION.

Fig. 5 represents the circuits of the two apparatuses of two stations, united by the line wire and the earth wires. This figure is simple, and explains itself. $P P'$ are the two batteries, of which $c c'$ are their copper poles, and $z z'$ their zinc poles, united by wires to the pressure screws, indicated by the same letters in station 2. $T T' F F'$ are the pressure screws, destined to receive the wires which go to the earth, and the conducting wires of the telegraph line. $c c'$ are two commutators, which communicate metallicly sometimes with the pressure screws $m m'$, when it is desirable to transmit dispatches, sometimes with the pressure screws $R R'$, when the telegraphs are to re-

main at rest; $E E' E' E'$ are the electro-magnets of the indicators, and of the bell apparatus, and $G G'$ are two electrometers, placed in the circuit in the drawing. The station 2, at

Fig. 5.

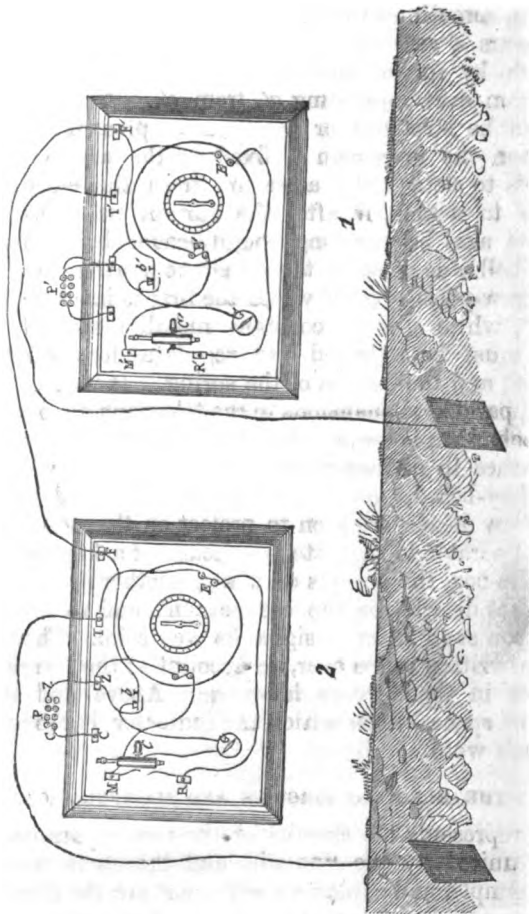

the left, speaks and transmits signals to the station 1, at the right. The course followed by the current is indicated by the line wires and the station connections.

To place the commutators in contact with $M M'$, it is sufficient to press the button b , fig. 5.

The needles of the two indicators move constantly over the dials; and to transmit signals, it is only necessary to stop

simultaneously the two needles upon the same letter. It has sufficed for this, to prevent the circuit from being closed in the apparatus at the first station, 1, producing the same results in effect. The circuit also rests open in the apparatus of the second station, 2; and neither of the two armatures will be attracted until the mechanism of apparatus 1 is permitted to close the circuit.

When the key of the first apparatus is pressed upon, the escapement wheel is stopped precisely in the middle of the movement which it was about to make, under the action of the spring, and the circuit cannot be again closed, until the operator has removed the obstacle by the withdrawal of the finger. During this time, nothing prevents the escapement of the apparatus of station 2, by its mechanism, from closing the circuit; but, inasmuch as the circuit is open at station 1, the armature will not be again attracted, and the indicator of the apparatus, at station 2, will stop over the desired letter, after the key is pressed corresponding to the same letter upon the apparatus at station 1.

In time of repose, when it is not desired to correspond, the circuit between the two stations, 1 and 2, is formed merely by the conducting wire, the earth, and the two spools or coils of the alarm bell. When the operator of station 1 wishes to communicate with the operator of station 2, he withdraws his bell apparatus from the circuit, and replaces it by a battery and his apparatus for telegraphing. Immediately, the bell of the station 2 gives the alarm, but the telegraph apparatus of that same station remains motionless. It may appear somewhat surprising, that two similar apparatuses, the telegraph and that of the bell, can be in the same circuit, the one operating and the other not operating. This effect is obtained by the unequal tension of the springs. Suppose, indeed, two apparatuses to be placed in the same circuit, the recoil spring of the one *A* is much stronger, or more tightly stretched than the apparatus *B*, thus, when the armature of *B* shall have been attracted, the electro-magnet *A* will not have acquired the force necessary to counterbalance the action of the spring. This result is owing to the difference as to tension in the recoil springs, the one being more susceptible and elastic than the other. The armature of *A* will remain firm and motionless, and the circuit constantly closed on that side. The apparatus *B* will alone move. It will be understood, then, that, from what actually takes place, the springs of the bell alarms are feebler than those of the telegraph. The bells will be sounded at each station, by the action of the battery of the other station, while the telegraphs will

continue to remain motionless. To completely establish the correspondence, the operator of station 2, being notified by the alarum, withdraws his bell apparatus from the circuit, and puts in its place the telegraph and the battery. The telegraph apparatuses then immediately work together. This simultaneity of movement will not take place if the operator of station 1, in giving the alarum, has not first introduced his telegraph into the circuit, and if his telegraph has not rested motionless while the bell of the other station is sounded.

If the operator of the second station wishes, in his turn, to correspond, or express some doubt, or ask some explanation, he places his finger upon a key, the needle of station 1 stops upon the signal corresponding to that key, and the sender of the dispatch is thereby notified that the operator of the other station wishes to speak. The interview then takes place, the explanations are exchanged, and the transmission of the signals is then resumed.

The normal movement of this telegraph is that whenever the needle passes over a demi-circumference of the dial. By this system, fifteen signals can be transmitted in a second. This rapidity is ordinarily attained. A Daniel battery, of five pairs, is sufficient to work a line of from one to two hundred miles. A battery of twenty-five pairs, with subterranean wires, makes the apparatus work very well over two hundred and fifty miles.

THE TRANSMITTER AND ITS APPLICATION.

To avoid increasing the number of pairs, an apparatus has been added to the Germanic telegraph, by the inventors, called a "transmitter," which is a peculiar relay magnet. When the circuit is closed, the current from the batteries of the stations do not enter at first into the two spools of the electro-magnets of the two stations. It passes first into the spools or coils of the transmitter, opposite the poles of which the armature turns, similar to those of the telegraph and of the bell apparatus. As soon as the armatures are attracted, they close an aperture which existed between the conducting stopper and the lever fixed to the armature, and when the armature is detached, the interruption is made to re-exist. The establishment and rupture of the contact is the only work performed by the transmitter. There can be given to their springs much less strength than that of the springs of the bells, and a very feeble current will suffice to give action to the transmitter.

When the transmitter has established the contact as above

described, the current of the battery has opened before it a de-activating circuit, much shorter and of less resistance, being composed of equal batteries and relay coils at each station.

These spools will then be traversed by a current much less intense, than if they had not had the transmitter. The armature of the telegraphs are attracted, and during their course, nothing is changed; but as soon as they have answered at the end of that course, the armatures interrupt the contact in the telegraphs. The current which animated the electro-magnets of the transmitters ceases, and the armatures of these magnets are detached by the springs. The auxiliary current, which rendered active the electro-magnets of the telegraph, ceases in its turn. The armatures of the telegraph are drawn back by their springs, and the indicators advance one step upon the dials, &c. The manœuvre for giving the alarum call is the same thing either with or without the transmitter. Fig. 4 will give an idea of the play of the transmitter or electro-magnet. It serves here to make a bell ring. $E E_1$ are the two poles of the large electro-magnet, the extremities of the wire which cover it go by the wires $F F_1$ to the two poles of a local battery. The wires of the transmitting electro-magnet terminate, one with the earth, and the other with the wires of the line. A is the armature of the small electro-magnet; it turns around a vertical axis, and bears the lever l , terminated by a hammer B , which strikes upon the bell at each attraction of the armature. The wire F goes directly to one of the poles of the local battery. The wire F_1 is at first attached to a metallic piece m ; to this same piece, but insulated from it, is attached the platina wire, which makes the very feeble spring r , of which the extremity is very near to the little platina prolongation of m , so that a very slight movement of the spring r serves to bring it in contact with m . The wire F_1 unites the spring r with the second pole of the battery. The prolongation of the lever l , or the second arm b , seen below the armature A , bears at its extremity two little pins, between which is engaged a rod, fixed to the armature of the electro-magnet $e e_1$; this rod is terminated by a little bead or button, which presses whenever the armature is not attracted against another similar button, borne by a second platina wire spring r_1 . The armature A and the armature e have their spiral springs $R R_1$, which tend to separate them from the electro-magnets, when they are no longer attracted. This being so, if the telegraphic circuit is strong enough, the electro-magnet $e e_1$ attracts its armature e , and this armature makes the spring r press against the metallic piece m , thereby the circuit of the local battery is closed.

The current circulates, and renders active the apparatus of the bell. The hammer strikes one blow, but at the same time its prolongation *l* detaches from the electro-magnet *e c*, the armature of the relay. The spring *r* abandons the metallic piece *m*, and the circuit of the local battery is again opened.

I have said, in the beginning of this chapter, that this description of the ingenious telegraph apparatus was defective. It is the best that I have been able to get. The system is worthy of a more extended notice. I have frequently visited the telegraph manufacturing establishment of Messrs. Seimens and Halskie, in Berlin, Prussia, and I found it to be the most complete and extensive in the world

FRENCH ELECTRIC TELEGRAPH.

CHAPTER XXIV.

The Nature and Origin of the System—The Receiving Apparatus—The Manipulating Apparatus—The Process of Sending Signals—The Formation of the Alphabet.

THE NATURE AND ORIGIN OF THE FRENCH TELEGRAPH.

THE French electric signal telegraph is of the needle order, but differs from that system in its index. It is fashioned after the semaphore of Chappé; the signals, however, are produced at the sending and destination stations, instead of at the sending station only, as in the semaphore. It will be remembered that, in the visual system, the receiving station observed the signals made at the sending station some miles distant therefrom. Those same signals are produced at the receiving station on an electric instrument by the operator at the sending station, any number of miles distant. A description of this apparatus I will embrace in this chapter.

It has generally been believed that this electric signal system for telegraphing has been preserved by the French administration, only because it reproduced the same character signals as the Chappé semaphore telegraph, and because it was not desirable to make modifications or changes of any kind in the vocabularies, or in the operative department of the telegraph. I notice that some of the French writers, among which Mr. Blavier may be named, deny the correctness of this impression. In 1854, when, by authority of His Majesty the Emperor, I made a careful and minute examination of the electric telegraphs of France, I certainly understood that the object of adopting the French electric system was to avoid the change which would be necessary in case of the organization of any other telegraph. This, however, is not a point of any consequence, nor does it lessen the merits of the French system. The apparatus was simple and beautiful. Hour after hour I have witnessed its operations with admiration, and I

can readily appreciate the regret experienced by the French in the abandonment of their national telegraph for the adoption of the Morse system.

For some years circumstances have wonderfully changed things in Europe, and in fact throughout the world; but in nothing has there been a greater change than in the means of communication. "The same principle which justified and demanded the transference of the mail on many chief routes through the countries of the different nations, from the horse-drawn coach on common highways to steam-impelled vehicles on land and water, was equally potent in warranting the adoption of the electric telegraph—that last and most wondrous birth of this wonder-teeming age."

Although the French electric signal system has been superseded and put aside for the recording apparatus, nevertheless it will remain in the history of the telegraph as one of the most ingenious, and as that which, at its commencement and during its continuance, rendered the most important services. Such is the impression of the Frenchman Blavier, with whom I cordially concur in the well-merited encomium expressed in his commendations.

The following is a description of the French electric signal telegraph. It will be seen that it does not differ from the dial-plate apparatus, except in the number of teeth in the escapement-wheel, which number instead of being 13 is only 4. The needle in turning, instead of stopping 26 times, stops only 8 times, and as the angles themselves suffice to determine the signals, it is useless to mark them on the dial plate.

Fig. 1.

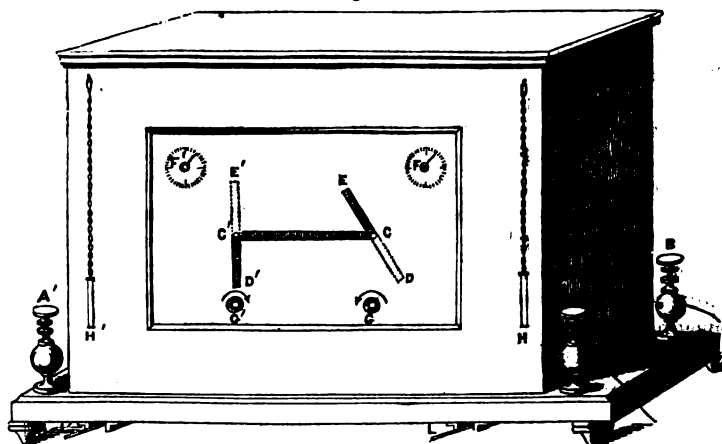

THE RECEIVING INSTRUMENT.

This apparatus comprises almost always two similar systems, so as to be able to operate with two needles.

D G E, D' C' E', fig. 1, are the two indicating needles, made of mica, blackened on the side which marks the signal. They are fixed by simple friction on the axis c and c'. g and g' are squares which correspond to the little barrel, and serve to wind up the clockwork. F and F' the axis of the pulleys, which are turned by means of little keys H and H', to tighten the recoil spring.

A and B, B' and A', are the knobs to which are attached the wires by which the current enters and passes off. The internal arrangement of this instrument will be seen by figure 2.

Fig. 2.

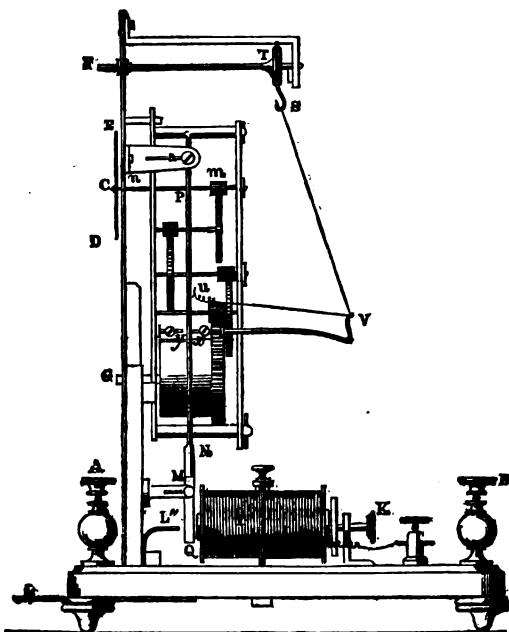

The electro-magnet i, instead of being at the upper part, as in a dial-plate apparatus, rests on the bottom of the case, and is held by two vertical rods, and a horizontal bar of copper. The soft iron of the electro-magnet may be advanced or drawn back by means of the screw k. The armature q m,

is movable around two screws, one of which is visible at *m*. The rod of the armature *n p*, is terminated at the upper part by a horizontal point, engaged in a fork. The axis bearing this fork, and the escapement anchor, are retained by the screw *a*—the disposition analogous to fig. 3.

Fig. 8.

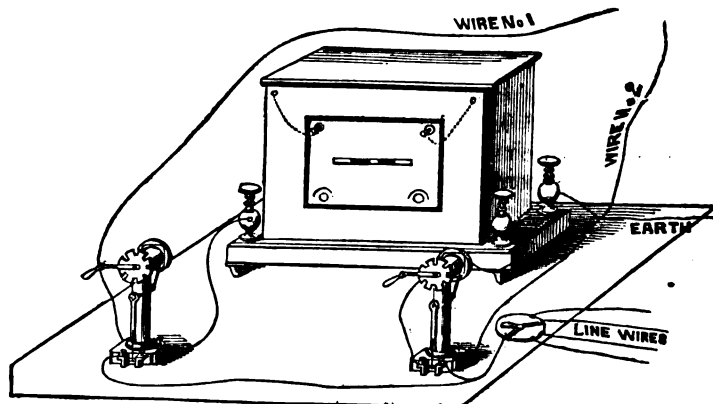

The clock-work is contained between two copper plates. The axis of the last wheel *m c*, bears the exterior needle *d*. *c e*, and the escapement-wheel furnished with 4 teeth, concealed in the figure by a rod of the armature. The two screws *x* and *y* limit the extent of the motion of the rod of the pallet.

The recoil spring is fixed at *u* to the rod *n p*, it is terminated by a wire passing in the hooks *v* and *s*, and is wound upon the little pulley *r*, the axis of which is prolonged as far as *f*.

L, figures 1 and 2, is a rod bent at *L''*, which serves to give direct motion to the armature. The wires of the electro-magnets terminate at two little buttons, which, by means of metallic strips, communicate with the exterior of knobs *A* and *B*.

The movement of the apparatus is the same as the dial-plate apparatus.

When the current traverses the wire of the electro-magnet, the armature is attracted, the rods set in motion the little fork and escapement anchor, which suffers a single tooth of the wheel to pass, and during the movement the needle turns through an angle 45° . When the current ceases to pass, the armature returns to its first position, and the needle turns again 45° .

The needle, therefore, produces a series of angles of 45° ; from 0° up to 360° .

THE MANIPULATING APPARATUS.

Fig. 4.

This instrument is formed of a vertical copper column, fig. 4, *A B*, terminated by a horizontal cylinder, *c d*. In the interior of this cylinder an axis turns, which is fastened on one side to the crank *E F*, and on the other side to the quadrangular grooved wheel *G H*, of which the angles are rounded. *I K* is a disk or divisor, having 8 notches, into which the crank enters, being pressed by an internal spring. An elbow lever, *L M N*, enters into the groove at *N*. At its other extremity is fixed to the rod *L P*, at the upper part of which is a little spring hammer which strikes alternately against two points of contact, *x* *y*. For the position of the crank marked 0, 2, 4, and 6, the hammer is upon *x*. For the other four positions, the hammer is on *y*.

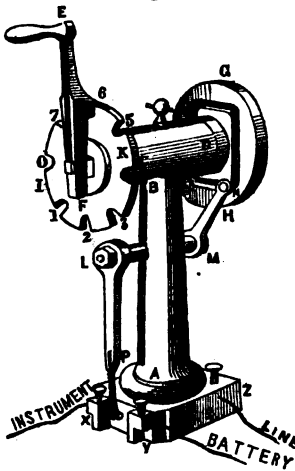

The two metallic pieces forming these points of contact, are insulated by means of an ivory plate, and they have little holes into which the wires which correspond enter, to the receiver for *x*, and to the battery for *y*. The wire of the line is attached at *z* to the base of the column.

When the crank is in one of the four positions, 0, 2, 4, and 6, the current coming from line at *z* passes into the column and over the rod *L P*, and over the spring hammer, over the point of contact *x*, and goes to the receiver, through which it passes in order to arrive at the earth.

In the other four positions the pole of the battery is in communication, by means of the point of contact *y*, with the spring hammer, the rod, and the column.

THE PROCESS OF SENDING SIGNALS.

The crank of the manipulator of one of the posts *A*, and the needle of the receiver of the other post *B*, have the same horizontal position. Let us suppose that we lower the crank and place it in front of the notch which bears number 1. At the same moment the current traverses the receiver of *B*, the needle turns through an angle of 45° , and remains in this position as long as the crank *A* does not change. If we place the crank upon the notch number 2, the current ceases to pass over the line, and the needle of *B* again advances 45° .

The same rotary movement takes place if we continue to turn the crank, and the angle which the needle forms with its primitive position is always the same as that of the crank.

In a state of rest, the receiver of the two corresponding posts ought to have their needles horizontal, the indicators concealing the bars traced on the dials. The cranks have the same position.

When we wish to send a signal to one of these, we turn the crank rapidly, passing first the upper part over the divisor, and we stop the crank at the notch corresponding to the angle which we wish to transmit. The needle of the other post immediately indicates the same angle. To produce a second signal, we continue to turn the crank in the same direction, as far as to the notch which represents the new angles. There would, evidently, be discord between the signals transmitted and those received, if we did not turn the crank in the same direction.

All the explanations, or descriptions of the dial-plate apparatus, apply also to the signal apparatus; thus, in order to regulate the apparatus, we tighten the screws *x* and *y*, so as to give a suitable play to the rod of the armature. We regulate the apparatus by causing to turn rapidly the crank of the corresponding post, and by tightening or loosening the recoil spring, until the movement of the needle shall become sufficiently rapid.

The electro-magnet can be advanced or drawn back when the current is too weak or too strong; but it is preferable to keep it at a very small distance from the armature.

The French apparatus operates ordinarily by means of two distinct wires. Fig. 4 shows the most simple disposition of a station.

The two column manipulators are fixed upon the table by strong screws, to correspond to the two wires of the line, and to the two sides of the receiver. The wires of the battery arrive at a communicator, which admits of the increasing or diminishing of the numbers of elements employed. A single wire extends from the communicator to the two manipulators. Although a single battery serves to transmit the current, either upon a single wire or upon the two, simultaneously, the intensity is so constant there is no perturbation in the transmission.

A single battery current has been found sufficient to operate this instrument on lines diverging in five or six directions.

The manipulation is performed by both hands. If we turn the cranks in order to stop at any two notches of the divisors,

the two positions which they take are reproduced identically by the needles of the receiver at the end of the line.

Small tables and special commutators are made for the apparatus.

One of the commutators is represented by fig. 5. The two wires of the line arrive at the binding screws *L* and *L'*. The current traverses a copper plate, furnished with points in front of the plate *T*, which communicates with the earth. *P* and *P'* are lightning rods; *R* and *R'* are the commutators which connect the two wires of the line with any one of the wires attached at *c* *B* *A*, and *c'* *B'* *A'*. At *A* and *A'*, for example, we place the wires which correspond with the two manipulators at *B* and *B'*, wires of direct communication; at *c* and *c'* are the bell-wires.

Fig. 5.

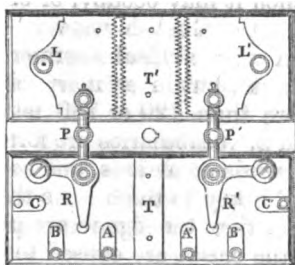

THE FORMATION OF THE ALPHABET.

The combination of the angles formed by the two needles furnishes 84 signals, which may represent the 24 letters, the numerals, the principal syllables, and several regulation signals.

When the indicator conceals the horizontal number of the apparatus, we do not indicate it in the drafting of the signal. When, on the contrary, it is on the prolonged line of the horizontal, we mark it with the index *o*. The regulation position is that of the closed.

The call is made by the return of the crank, to which the correspondent answers in the same manner.

Every transmission of a dispatch commences with the "open." "Activity" precedes all private dispatches, and "urgency" precedes every official dispatch; but of this full explanations are given in another part of this book. The end of the word is indicated by closing the indicators.

When the signals are unintelligible, the receiving operator interrupts his correspondent or the sending operator, by turning the crank, and he passes the last word understood. On both sides the normal position of the cranks and indicators is re-established, and the correspondence goes on again, commencing with the last word understood, as common to all modes of manipulation. By having a key, or a pre-determined signal preceding the signals, 64 new combinations are obtained, by means of which we form tables of conventional phrases.

The transmission takes place with wonderful rapidity. The

reading is also rapid, for the signals are drawn by the angles which they make without the necessity, as in the dial-plate apparatus, of following the needle through the 26 positions which it may occupy, or of mentally counting the movements as in the English system.

A very skillful operator can pass as high as 230 letters a minute, but in ordinary circumstances we cannot count upon more than 120 or 130 letters. By combining the signals 2 and 2, vocabularies are formed containing an indefinite number of words or phrases, and so complicated that it is impossible to find a key to them. As these signals have no intelligible signification, the signals are passed by ten at a time, and each ten of the closed are caused to follow in such a way that when the crank and the indicator do not agree, it is readily seen. In such a case the ten seen to be erroneous are repeated.

The vocabularies can be taken, either by signals themselves, which are easily written, or by the letters and figures which they represent, according to the alphabet formed by the angles on the receiver. In the manipulation frequently the signals are named directly, using abstractly the letters or figures which they represent. Instead of designating them by their absolute value, the angles formed by the needles, or applying to them the simple numbers represented in the alphabet and numeral code, use is made of the ancient system of Chappé.

Zero is called the position of the needle at rest. Five, corresponding to an angle of 45° ; ten, corresponding to an angle of 90° ; fifteen, corresponding to an angle of 135° . To which is added the word "sky," to words formed above the normal or horizontal position, and the word "earth" to angles formed below it. Finally, when the needle is on the prolongation of the line of the centres, it is indicated by the term "great zero." In the denomination of a signal, commencement is always on the left side. In the formation of angles by the two needles, a single expression is made.

The signals formed are analogous to the aerial telegraph. Therefore the old vocabularies have been preserved for secret dispatches. The aerial telegraph can exhibit all the combinations of this system, except those which correspond to the case when the needle is on the prolongation of the dial; but the Chappé telegraph can furnish the same signals *carried vertically*.

In order to indicate the horizontal or vertical position of the signals, before the signal to be carried vertically, is placed the index o.

In many instances the transmission takes place by means of

a single wire, whether use is made of a special apparatus having a single indicator, or whether an apparatus is employed of two indicators of which only one operates. This must necessarily take place when the lines have but a single wire, or when the different wires of a line are separated in order to correspond with several stations. In this case, the same alphabet is used as on the instruments constructed for two wires; but the signals are divided into two parts, and are made by a single indicator. First, form the angle of the left, and then make the angle of the right. This change, which at first seems to render the manipulation complicated, is attended with no difficulty in practice, and a few days are sufficient to accustom the operator to its use.

The transmission by a single wire is slower than by two wires; but the signals thus passed are not reduced to one half. From 80 to 90 letters per minute, instead of 130, can be sent with facility. The rapidity of transmission is claimed to be greater than that obtained by a dial-plate apparatus, although it requires two stoppages for each letter. The reason is explained thus: for two turns of the crank, that is to say, for eight emissions of the current, are produced 64 combinations—while only 26 are obtained with the dial-plate apparatus, in the French instrument, and the current passes 130 times.

When two lines, each of one wire, terminate in the same station, and the operator is required to transmit in the two directions, these two wires are generally placed at the two sides of the same apparatus, thus occupying a middle or betwixt position. Attempts have been made to use repeaters in connection with the French system, but all the efforts have proved unsuccessful.

For ordinary purposes, however, it will be sufficient to insulate the two screws *x* and *y*, fig. 2, by means of strips of ivory, and to make them, as well as the pallet, communicate with the exterior, binding screws, which will establish the following communication:

1st. The screw *x*, with another similar receiver. 2d. The pallet with one of the lines which terminate at the post; and 3d. The screw *y* with the battery.

THE FRENCH RAILWAY ELECTRIC TELEGRAPH.

CHAPTER XXV.

Principles of the French Railway Telegraph—Description of the Receiving Instrument—The Manipulating Apparatus—Process of Manipulation between Stations—Portable Apparatus for Railway Service—Breguet's Improvement.

PRINCIPLES OF THE FRENCH RAILWAY TELEGRAPH.

THIS apparatus is founded upon the principle of the movement of a clockwork, which turns an exterior needle, fixed to the same axis with an escapement wheel, the rotation of

Fig. 1.

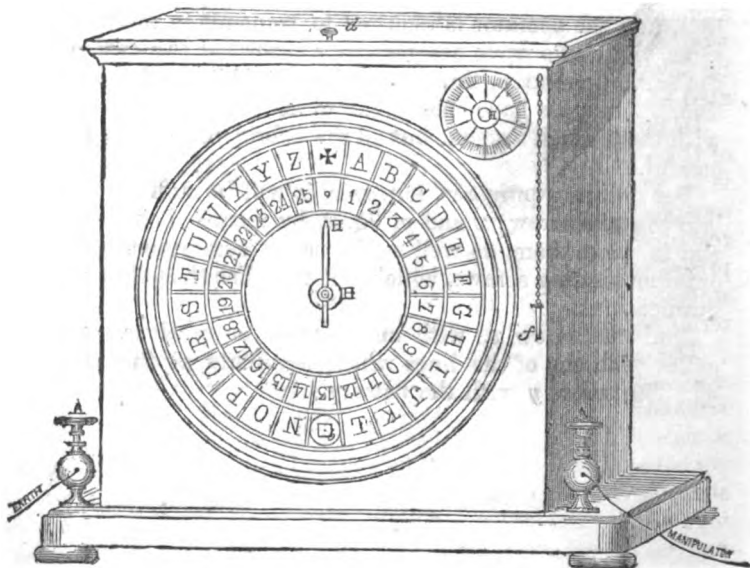

which is stopped by an anchor. A soft iron armature, moveable in front of an electro-magnet, communicates an oscillatory movement to that anchor, which, at every movement, lets a tooth of the wheel pass. The exterior dial bears letters, signs, or figures, and the needle may stop before any one of them. The whole is contained in a case, in which the dial alone is exposed to view. The model of the apparatus illustrated and explained in this chapter, is the same as that used in the telegraphic bureaux of France. The same system, a little modified, I noticed on the Belgian railways. It has proved to be of the greatest utility in the service, and every railway has in perfect organization this system of telegraph, having an office, or bureau at every station.

DESCRIPTION OF THE RECEIVING INSTRUMENT.

The receiver of this telegraph will be seen in fig. 1; it is inclosed within its cover. The dial has 26 divisions; the upper is a cross, and the other divisions are the alphabet. The first 25 numbers are placed on the interior of the dial-plate. The needle, $н н'$, is made of mica or steel, nicely balanced, and fixed frictionally on the axis of an escapement wheel. At the upper part, on the right hand, is a little dial, of which the axis a acts with the recoil spring of the armature. The two screws or binding posts, $а а'$, serve to fix the wires by which the current enters and leaves. At the place of the letter $м$ in the alphabet is a square, b , by means of which the clock-work is wound up. When the current is not passing, the needle may be advanced, by pressing on the button or thumb-key d , situated at the upper part of the case.

In fig. 2 is represented a side view of the vertical projection of the apparatus. Fig. 3 is a horizontal projection, and fig. 4 is a perspective view of the armature, the anchor, and the escapement wheel. In all the figures, the same objects are represented by the same letters. The clock-work movement is comprised between two copper plates, $в c$ and $д e$. The little barrel, $м$, contains a large spring, and its axis corresponds to the exterior square represented at b , in fig. 1.

The axis of the upper wheel, $г г н$, bears an index needle, $н н'$, and the escapement wheel, concealed in fig. 2 by the armature-rod, but visible at L , in fig. 4. The electro magnet $к$, figs. 2 and 3, is placed above the clock movement, on a copper plate, $д д'$. It is held by two vertical posts, and a copper strip, $w w'$. The two soft iron rods of the electro magnet, held together by a third rod, $к$, are independent of the spools, and can be moved by means of the screw-adjuster $L L'$. In order

to move forward or draw back the electro magnet, it is sufficient to turn the screw for the purposes respectively. The ex-

Fig. 2.

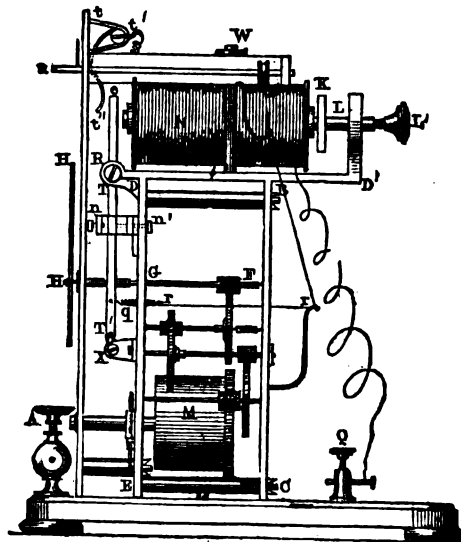

tremities of the covered wire spools terminate at two screws, or binding-posts, q q' , which, by means of two metal strips, communicate with the exterior binding-screws, A A' .

The armature R e , placed in front of the electro magnet, is moveable around the two screws, R and R' . The rod T T' , fig. 4, suspended from the middle, carries at its lower part a little horizontal point T v , engaged in a little fork, which is attached to the axis x y ; finally

in the middle of this rod, at z , is formed two little slips, m and m' , situated in planes differing from each other, and below the escapement wheel L , which has 13 teeth.

Fig. 3.

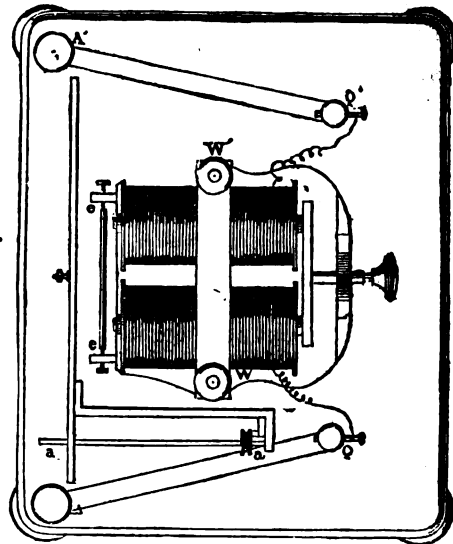

By means of the clockwork, the escapement wheel is caused to turn in the direction indicated by the arrow, but one of its teeth is stopped by the point *m*. When the current passes, the armature is attracted by the electro-magnet. The rod causes the axis *x y* to turn a little. The slip *m* withdraws, and permits the tooth to pass, which strikes against the strip *m'*. It rests thus, until the moment when the current ceases to pass, when the armature returns to its first position. The strip *m'*, being withdrawn, permits a tooth of the wheel to pass, and another tooth is stopped by the strip *m*.

Fig. 4.

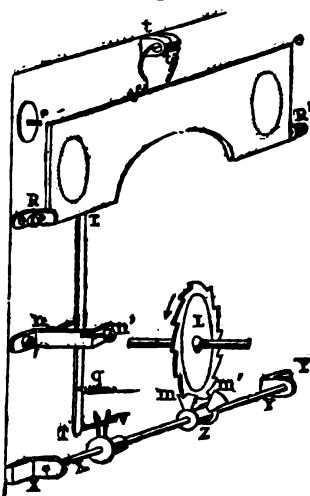

The exterior needle, fixed to the same axis, turns then with each complete oscillation of the armature through $\frac{1}{3}$ of the dial, and for each half-oscillation through $\frac{1}{6}$ of the dial. Thus, when the current traverses the wire of the electro-magnet, the needle advances through one division; if it is over the cross, it comes opposite letter *A*. When the current is interrupted, the needle advances again, and places itself in front of the letter *B*, and so on. In order that it may make a complete circuit, 13 emissions of the current are necessary.

The two little screws, *n* and *n'*, being fixed to a copper piece, which unites the plate *D E*, limits the play of the rod *r r'*. The recoil spring is a little spiral spring attached at *q* to the rod of the armature; it is terminated by a wire, *r r' a'*, which is coiled upon a little pulley at *a'*, the axis of which is prolonged to the exterior of the box or case as far as to *a'*.

At the upper part of the dial is a little rod *t t'*, which, when pressed down, turns around an axis, and gives motion to the bent strip *t' t''*, and this strip then presses the armature against the electro magnet, and produces an effect similar to the passage of the current. It is by lowering the exterior thumb-button *d*, fig. 1, that this movement is produced.

The apparatus is put in an operating state by means of two little screws, *n* and *n'*, which should be so tightened as to give to the rod of the armature the least possible play, allowing it, nevertheless, sufficient play to permit one of the teeth of the escapement-wheel to pass at each movement. It then remains

to regulate the motion of the needle, according to the intensity of the current. The electro magnet may be advanced or withdrawn, and the recoil-spring may be tightened from the exterior by means of the little key *f*, fig. 1. The apparatus is known to be regulated, when the needle turns regularly under the action of a series of rapid interruptions of the current. Sometimes the strips *m* and *m'*, fig. 4, are a little too far apart, and at a single movement of the armature, several teeth of the escapement wheel pass; in such cases, the two strips must be brought nearer together, or the screws *n* and *n'* must be put farther apart. When the play of the armature is too much, it may happen that the strips *m* and *m'* may both be, at a given moment, on the same side of the escapement wheel; the clock movement being no longer held, the wheels turn with great rapidity, until the spring has exhausted its action. When this part of the apparatus is touched, the little barrel *m* should be held by the hand, to prevent a rupture of the great spring and of the needle.

THE MANIPULATING APPARATUS.

The manipulator, fig. 5, is formed of a square plate, upon which rests a brass dial, bearing on its circumference, in front, notches, the same as the letters on the receiving apparatus, and disposed in the same order.

A crank, *A B*, pointed at the centre of the plate, gives motion to a spirally grooved wheel, which is partly shown in fig. 5. The regular sinuosities of this wheel are equal to the number of characters on the dial. The rotation of this wheel produces a to-and-fro movement of the lever *I O F*, which is moveable around the point *o*, and of which the extremity *F* is terminated by a little spring *F D*, which touches alternately the two screws *P*, and *P'*, which are fastened to *c*, the little copper pieces, as shown in fig. 5. Whenever the crank is over an even number, the lever presses on the binding screw *P'*; when the crank is over an odd number, the lever presses on the binding screw *P*. During a complete revolution of the crank, the lever touches the binding screw *P* 13 times and *P'* 13 times.

N V and *N' V'* are two springs moveable around *N* and *N'*, and can be made to press upon any of the strips, *L K H* and *L' K' H'*. Metallic communications are established beneath the plate between the different binding screws, which are seen on the manipulator: *P* communicates with *c*; *P'* with *E* and *E'*; *z* with *T G G' H* and *H'*; *L* and *L'* with the axis *o* of the lever: *c* is made to communicate with the copper pole of the battery, *z* with the zinc pole, and *T* with the earth. The two wires of the re-

ceiving apparatus are attached at *e* and *e*, or at *e'* and *e'*, and the line wire is attached at *n* and *n'*.

At *h k* and *h' k'* are fastened the bell wires. The two commutators *n v* and *n' v'*, enable the operator to employ a single manipulator in two different directions. When it is desired to correspond, the spring *n v* is placed in contact with *l*.

In the position of fig. 5, the current coming from the line *x*, follows the route *n l l' o f p' v e*, traverses the receiving apparatus, and returns to *e*, when it goes to the earth by the wire *g t*. In order to transmit, the crank, *a b*, is turned, and by placing it on the letter *A*, the spring, *o d*, comes into contact with the binding screw, *p*, the current leaves the copper pole of the battery, follows the route *c p f o l' l n*, and passes to the corresponding station in the direction of *x*. It produces an attraction of the armature and the needle of the receiving apparatus, and advances over the letter *A*. On placing the crank over *B*, the lever, *o b*, resumes its position, the current is in-

Fig. 5.

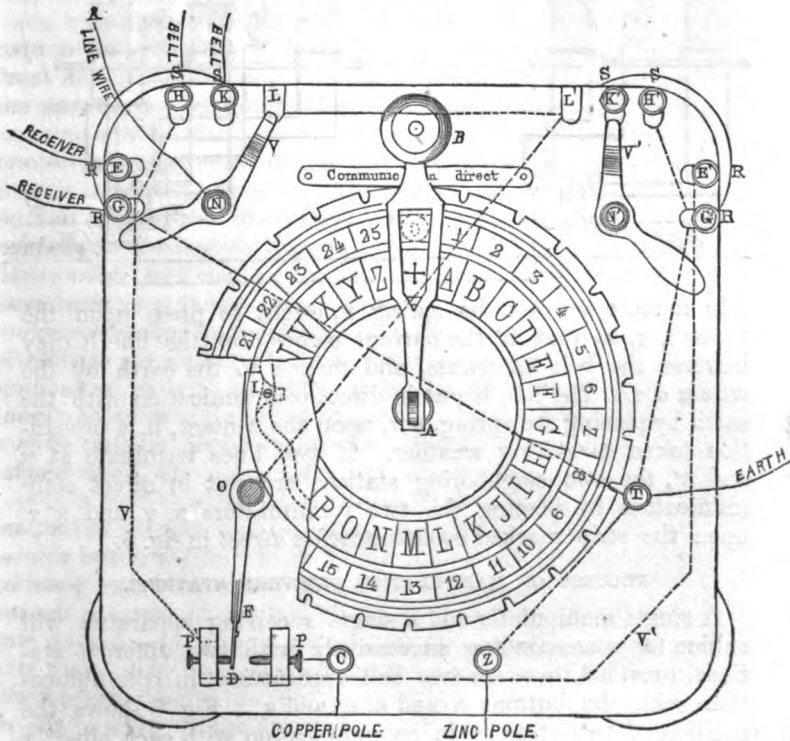

interrupted, and the needle at the station in communication advances through a new division and places itself above B. If the needle of the receiving apparatus and the crank of the manipulator are upon the cross, and if the crank be then turned rapidly and stops it at any letter desired, the needle of the receiving apparatus at the extremity of the line, will indicate the same letter.

When, instead of turning the crank according to alphabetical order of the letters, it is turned backward, the indicating needle of the station in communication continues to turn in the same direction, and the letters received do not agree with those sent. To re-establish an agreement between them it is necessary to bring the crank back to the cross on the one hand, and to make the needle advance by means of the thumb button, *d*, until it is over the cross.

Fig. 6.

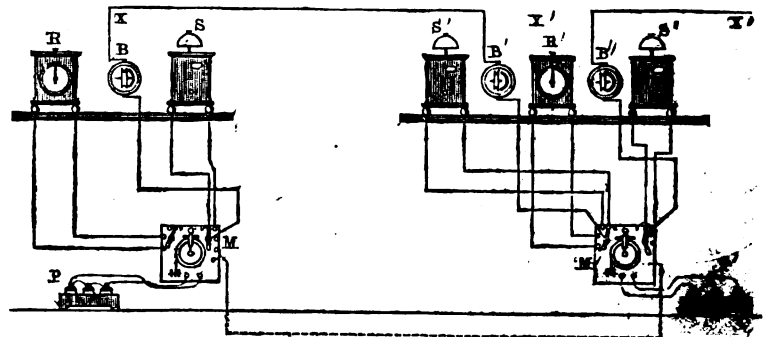

In a state of rest the spring, *n*, ought to press upon the contact, *k*, so that if the current comes over the line it may traverse the bell apparatus, and thence to the earth by the wire *H G T*. The line is put in direct communication with the earth by placing the spring, *n v*, upon the contact, *h*, a precaution taken in stormy weather. If two lines terminate at *n* and *n'*, the two neighboring stations are put in direct communication by placing the two commutators *n v* and *n' v'* upon the strip marked *communication direct* in fig. 5.

PROCESS OF MANIPULATION BETWEEN STATIONS.

A single manipulator and a single receiving apparatus will suffice for corresponding successively with two different stations, provided there are two bell apparatuses, in communication with the buttons *h* and *k*, *h'* and *k'*. Fig. 6 shows the position of two stations in communication with each other, *x*

and x' , of which x is the first station, in communication with x' , the second station, and x' with the third station x'' , $P P'$ are the batteries; $M M'$ the manipulators; $R R'$ the receivers; $S S' S''$ the bell apparatuses, to be described hereafter; $B B' B''$ are the galvanometers, which are constantly in the circuit and indicate the passage of the current.

In the normal position, the commutators or circuit connectors are placed on the contacts which communicate with the bell apparatus; the needles of the receivers, and the cranks of the manipulators, are upon the cross.

When an operator of a station wishes to send a dispatch, he places the commutator attached to the wire by which he wishes to transmit, upon the contact points L and L' , fig. 5, and sends the current by turning the crank. The operator of the station in communication, having been warned by the movement of his bell, places his commutator in the same way, and indicates, by a turn of the crank, that he is ready to receive. The operator of the other station sends his dispatch, letter by letter, turning the crank regularly, and stopping for a moment upon each letter he wishes to send. If he happens to pass a letter which he ought to have sent, he must be careful not to turn backward, but continue turning until he arrives at the letter by passing the cross. To avoid confusion, he ought to stop at the cross after each word. When the transmission is completed he turns the crank and stops it at the letter z , and then brings it back to the cross. The signal z is called the final.

The operator of the receiving station, if he has understood the dispatch, responds immediately by giving the two letters c o . At both stations the operators then place their commutators back upon the bell apparatus.

It is said that an expert operator can easily send from 60 to 70 letters per minute. If the dispatch contains numbers expressed in figures, indication thereof is given by stopping the crank twice over the cross, indicating that the following signals are to be taken from the figures. When in the course of the transmission, the signals become unintelligible, the receiving operator makes a turn of the crank, to inform the transmitting station of the fact, and he stops a moment to make the needle of his receiver come back to the cross, an operation which takes place at the same time at the sending station. He then passes the two letters r z , meaning "Repeat," which letters are placed immediately succeeding the last word understood. He then comes back to the cross and waits for the continuation of the dispatch, by the sending operator.

The needle of the apparatus sometimes does not turn regu-

larly; the transmission is then imperfect, and the apparatus must be properly adjusted. In such a case, one of the operators requests the other to turn his crank, when he tightens or loosens the recoil-spring, by means of the little key used for that purpose, until the needle moves regularly; this process completes the adjustment. The other operator then corrects his instrument by the same process, the adjusted station sending a current to the other, by the turning of the crank.

In order to transmit to a more distant station, call is made for the "communication direct," which is effected by turning the crank, following it by the name of the station wanted, and the number of minutes desired for the business is also mentioned. The station notified of this wish, answers *E O*, and immediately places the two commutators or circuit connectors upon the metallic strip, if "*communication direct*."

• The next succeeding station is notified in the same manner, which also makes the connection direct. In the same manner the successive stations are notified.

An operator ought always to answer to the call which is made, immediately. If occupied in another direction he passes the two letters *A Z*, which means "wait." When he is ready he should notify the other station.

To simplify the transmission, conventional tables of signals have been made combining figures 2 by 2, indicating certain phrases, as 5.17, "the train is starting." Notice is sent beforehand that these signals will be sent.

The manipulator may have several commutators similar to *N V* and *N' V'* and may serve to communicate in more directions than two, provided there is a special bell apparatus for each line. Nevertheless, it has been found injurious to multiply the commutators, for the reason that they are not readily understood by the employés of the railway, who take part in the telegraphic service as a secondary affair.

The dial plate apparatus leaves no record, no traces of what has been sent, consequently the reading of the signals requires the closest attention. Its movements are quiet, and the eye must be devoted to the signals and nothing else. The manipulation is so simple, that a person inexperienced in telegraphing may, at once, comprehend the system, at least be able to send dispatches. This apparatus will always be very useful for railways, and also where the telegraph is a mere auxiliary.

PORTABLE APPARATUS FOR THE RAILWAY SERVICE.

Fig. 7, represents the portable apparatus constructed by M. Breguet for the French railway service. It is very small, as

will be seen by the dimensions marked upon the figure. This instrument is designed to be carried in one of the cars of a train, and it is so arranged that it can be readily attached to the line wires. The dial, *r*, is the same as represented by fig. 1. The dial, *m*, is the key-board and crank represented by fig. 5. The upper part, *c c*, is fastened with hinges, and can be let down so as to cover the apparatus *m* and *r*, forming a square box, and in size some 8 by 10 inches.

Fig. 7.

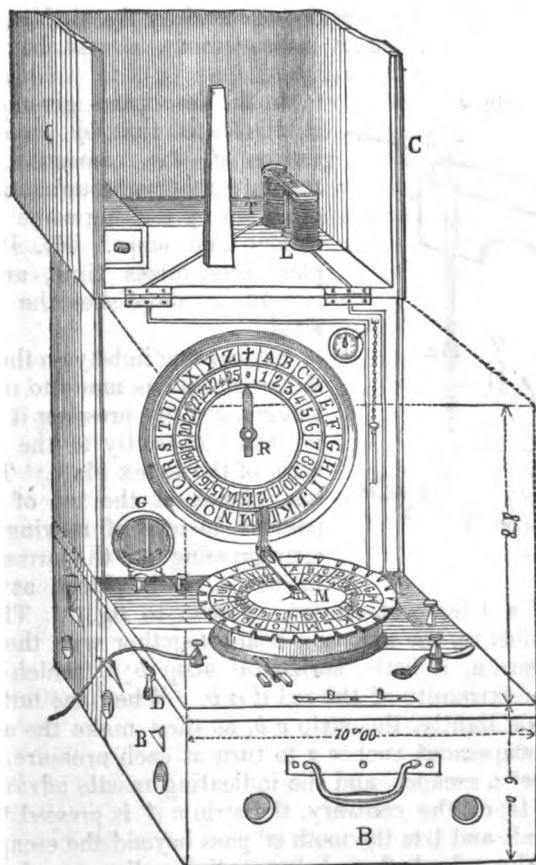

I do not consider it necessary to explain the manner of operating this apparatus, as the same explanations given of the preceding figures apply to this instrument. It is smaller than the

ordinary office apparatus, but in its construction it is the same. In case its use becomes necessary, by a train, the line wire is out and connected through the instrument, and thus, means of communication is speedily formed with an office to the right or to the left, as the case may be. The arrangement is simple and easy to be operated. The contrivance exhibits much ingenuity, particularly in the simplicity of its manipulation.

BREGUET'S IMPROVEMENT.

In regard to the clockwork indicated by fig. 4, Mr. Breguet has made a very valuable improvement, as will be seen by fig. 8.

Fig. 8.

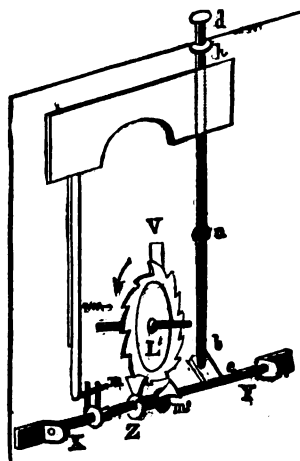

In the description given of fig. 1, it was stated that by pressing the button *d*, the respective instruments would be brought in unison of action by making some 13 revolutions and stops. Mr. Breguet's plan economizes time, and more speedily accomplishes the end desired.

By pressing lightly on the button *d*, the needle is made to move one single notch, by pressing it strongly it passes instantly to the cross, or zero, of the index plate. The button, placed at the top of the apparatus, instead of moving a little strip pressing on the armature, as in fig. 4, it is placed at the extremity of a long vertical rod, as seen in fig. 8. The spiral spring *h* holds up the axis, *x y* bears, together with the escapement anchor *z*, a little horizontal strip *b c*, which presses against the extremity of the rod *d a b*. When the button *d* is pressed upon lightly, the strip *c b*, as they make the axis *x y*, and the escapement anchor *z* to turn at each pressure, a tooth of the wheel *L* escapes, and the indicating needle advances one division. If, on the contrary, the strip *c d* is pressed forcibly, it is lowered, and lets the tooth *m'* pass beyond the escapement-wheel *L*, the wheel then being entirely disengaged, rapidly turns, bearing with it the needle. The rotation stops promptly, because the axis *L* bears a point *v*, which hits against a projection *a* of the rod *d b*.

At the moment when the rod *d b* is raised a little, the pro-

jection *a* disengages the stop *v*, but the slip *m'* of the escape-ment anchor engages again with the teeth of the wheel *L*, and, finally, when the rod rises entirely, the tooth *m'* comes in its turn to stop the movement, and the receiver is in its normal state.

The stop of the wheel *L* always takes place in the same position as occupied by the needle, and if it corresponds exactly, when the needle is in front of *z*, it is clear that, by lowering the rod forcibly, and letting it spring back quickly, the needle is brought from any position whatever to the cross. The needle will pass over the *z* during the very short time that the strip *m'* requires to come back in front of the wheel *L'*.

Experts are of the opinion that the rod of the armature might be a little modified, so that the little fork and the rod may incline with the anchor. It is terminated by a spring, which does not prevent it from causing the anchor *x y* to oscillate. It is the action of the spring which brings back the anchor *z* to its ordinary position, when the rod *d a b* ceases to press upon the strip *c b*.

ELECTRIC TELEGRAPH BELL APPARATUS.

CHAPTER XXVI.

The French Telegraph Bell Instruments—Vibratory Bell Apparatuses—Use of Bells in Telegraph Offices.

THE FRENCH TELEGRAPH BELL INSTRUMENTS.

THE greater part of the telegraphic stations are furnished with bells, which enable the different offices to call each other when the operator desired is not at the station, or to awake him in the night. They are indispensable at the railway stations, as the employés are not experts in telegraphing, having their services divided with the railway and the telegraph.

The bells are formed with a clockwork movement, by which a wheel, stopped by the armature of the electro-magnet, is disengaged at the moment when the current is sent by the operating or sending station. The rotation takes place for a longer or shorter time, and causes a hammer to oscillate, which strikes upon the bell.

The apparatus which is employed in the state telegraph office in France, is arranged in a case traversed by the hammer and the bell-rod.

Figs. 1, 2, and 3, gives three vertical projections, as seen in three different directions.

The clock movement is comprised between two vertical copper plates, *A B* and *C D*, fig. 3. The barrel *F* contains the large spring, which is wound up from the outside, by turning the axis *f* with a key. This barrel causes the two axes, *g* and *h*, in fig. 5, to turn, of which the first connects in front of the plate *A B*, fig. 1, to the eccentric *e*, fig. 1, formed of a circle, cut by two parallels, and the second connects to a circle *h*, fig. 1, which gives motion to the lever-arm *HI*, and also a to-and-fro movement to the lower part *I* of a hammer, *IKL*, moveable

around k . Behind the other plate, $c d$, as seen in fig. 2, is the electro-magnet $\epsilon \epsilon$, of which the wire is attached to two binding-posts, in connection with two exterior screw or binding posts.

Fig. 1.

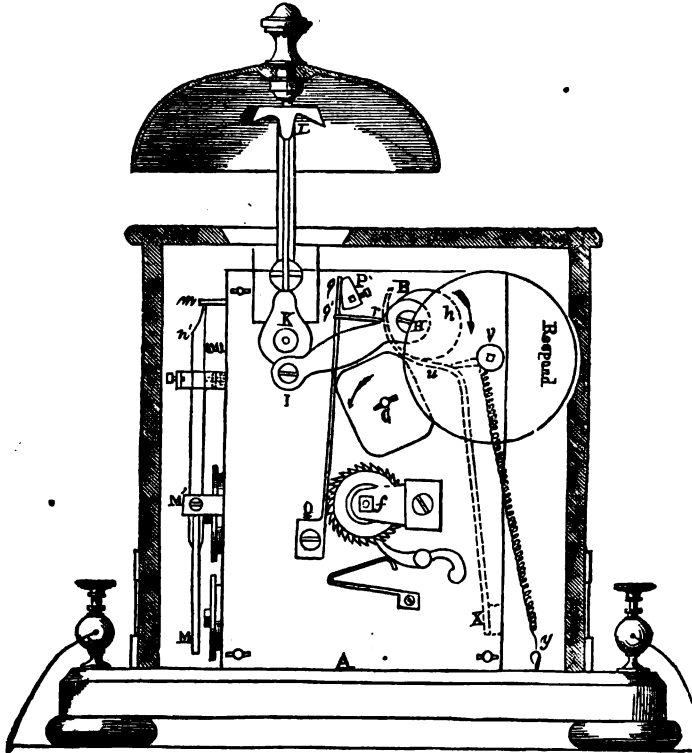

One of the screw posts connects with the line, by which the current is to arrive, and the other with the earth. The armature, $m m'$, is moveable around m' . Its rod, $m' n' m$, moves between two screws, limiting its course. The recoil-spring is tightened by means of the screw n . A little strip, $p_1 o' m$, drawn down by the spring $o o'$, presses upon the upper part of the armature-rod, and descends when the armature is attracted by the electro-magnet.

The axis p_1 , which traverses the two plates, is invariably fixed to the rod $p_1 o' m$, and to the quoin p_1 , fig. 1. It turns when the rod $p_1 o' m$, fig. 2, descends. One of the sides of the quoin

r' , in a state of rest, is vertical, and presses against the spring $q, q' q$.

The circle h , fig. 1, which turns with the eccentric e , bears a little rod, which it moves on turning in the direction indicated by the arrow, and which hits against the portions $q' q$ of the spring $q q q'$, which is wider at $q' q$ than $q q'$.

Fig. 2.

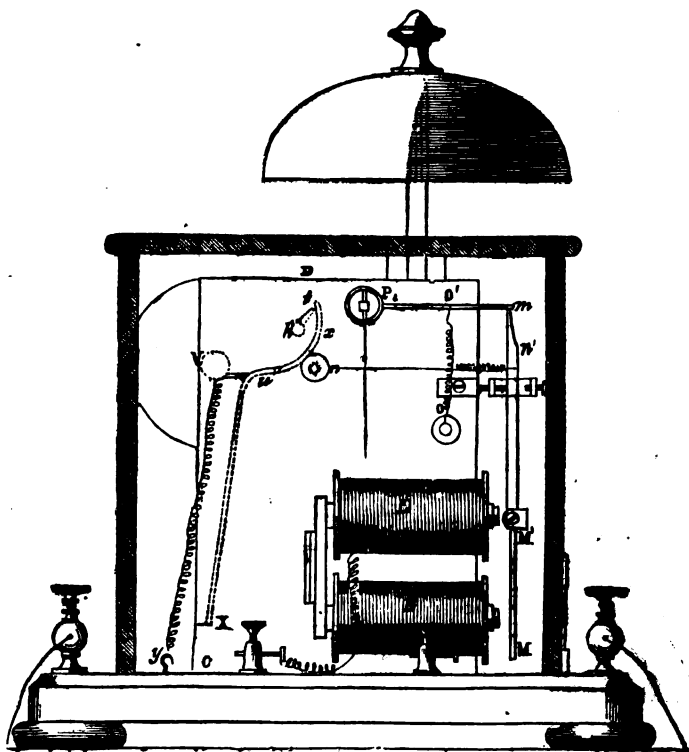

In the position of the figures, the rod r being stopped, the rotation of the axis h and e , in fig. 3, cannot take place. When a current arrives from one of the exterior screw or binding-posts, in traversing the wire of the electro-magnet, the armature $m' m$, fig. 2, is attracted, and $m' n' m$ withdraws a little, and the strip $p, o' m$, descending under the action of the spring $o' o$, fig. 2, causes the axis p , fig. 3, to turn a little. The quoin r' , fig. 1, inclines toward the left, and draws back the spring $q q' q$. The rod r is not stopped, and the wheel h , fig. 1, turns as well as the eccentric e , fig. 1, of which the bent part engages with the spring

q q' , and keeps it drawn back during all the time required to make a half revolution. During the rotation, the eccentric H puts in motion the lever-arm $H I$, and the hammer, which strikes on the bell. As the quoin comes back to its vertical position, the spring, after it has ceased to be passed by the curvilinear part of G , stops the rod r again, and interrupts the movement of the hammer.

Fig. 8.

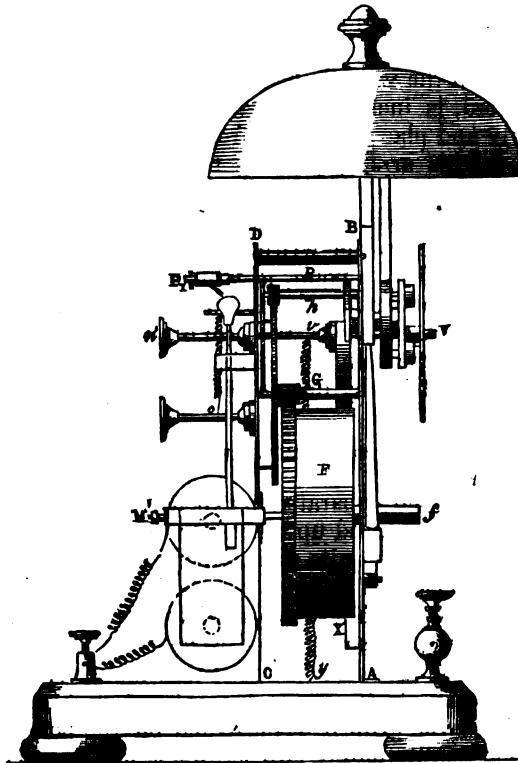

It remains now to be shown how the quoin comes back to the vertical position. Its axis, P , bears a rod which is seen in fig. 3, between the copper plate c D , and the large wheel, the axis of which is G . At the extremities of one diameter of the wheel are fixed two points, and when the wheel turns, these points press upon the rod and turn the axis, P , which raises the strip, P_1 $o' m$, fig. 2, and the quoin, r' , fig. 1.

If the current has ceased to pass, the armature is brought back to its position; the strip, P_1 m , presses again on the upper

part of the armature $m' n' m$, fig. 2, and the movement is stopped. If, on the contrary, the current passes, the rod is lowered again, and the play of the bell apparatus continues. Thus, when a single emission of current is produced, the bell apparatus continues to go while the wheel, c , is making a half revolution.

There are frequently several bell apparatuses in the stations, as the employés are not always present when required, and it is important that there should be some indication by which the station making the call could be known to the operator when he returns to the service. To this end, a disk is fixed, upon which is written the word *answer*. The part of the disk which bears this word, is inclined, and when the bell rings, it raises itself quickly and places itself in front of a little window cut in the case. This arrangement is thus described: This disk is fixed on an axis, v , fig. 1, to the middle of which a spiral spring, $v y$, is attached. The spring, $v y$, tends to make the disk turn and raise up the writing on it. The movement of this axis is stopped by a point, u , which the bent spring $x x$, fig. 2, holds. The axis h is formed with a little arm $h'' t$, fig. 2. When that wheel moves, the arm draws back the spring $x x$, which releases the point u and the disk rises rapidly. It is lowered on the outside by means of a little key.

VIBRATORY BELL APPARATUS.

The preceding bell apparatus is expensive and quite complicated. It must be wound up whenever the spring has executed its action, which is quite an inconvenience when it is to be intrusted to the care of inferior agents in the service of the railway companies, such as the guards, workmen, &c.

I will now give a description of a new bell system, which offers great advantages on account of its simplicity.

Let there be an electro magnet, $A B$, fig. 4, and an armature, $c D$, with its lever arm, $D O$, moveable on the point, O . The rod, $O D$, touches alternately two screws, m and n . The rod, $O D$, is in communication with the wire, $O P$; the point, m , with the wire of the electro-magnet, of which the other extremity reaches to q . When the two extremities, P and q , are placed in an electric circuit, the current traverses the wire of the electro-magnet and the armature, $c D$, is attracted. The rod at the same instant is withdrawn from the screw, m , and breaks the circuit. The horseshoe core of the electro-magnet ceases to be a magnet, and the armature $c D$, yielding to the action of the recoil spring, $I H$, returns to its normal position. The

circuit is again closed, and the movement taking place again, a series of vibrations are produced.

Fig. 4.

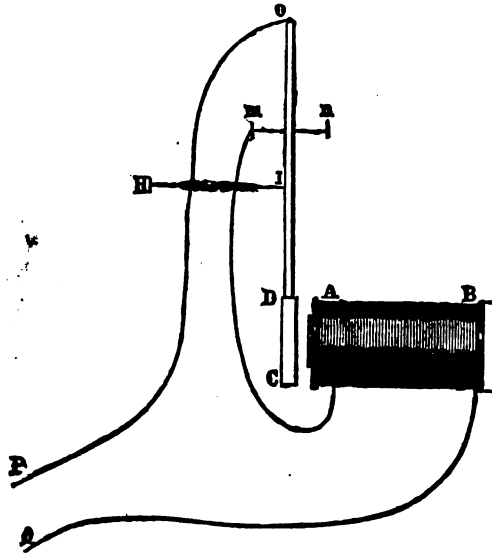

This apparatus, in the French service, is called a *trembler*. The width of the vibration is extremely small, when the current passes quickly on and off the electro-magnet; but if there be added to the screw *m* a small spring, which may press slightly upon the armature, at the moment when it withdraws from the rod, the movement becomes much stronger.

The bell apparatus, fig. 5, is contained in a box, the outside casing of which is seen. The bell *r* is placed over the box; the armature *L N* is terminated at the upper part by a little hammer *M*; it is moveable around the point *K* by means of a spring, which draws it from the electro-magnet *A A'*, and serves in the place of a recoil-spring.

Another spring, *I D*, presses upon the rod for a moment, when the armature is attracted by the electro-magnet. The fixed point *I* of the spring *I D* is connected to the exterior screw-post *B* and the point *K*, by means of the wire of the electro-magnet to the screw-post *C*. The movement of the bell apparatus is produced as has been above shown. All the time the current is coming over the line, the hammer strikes a continuous series of blows upon the bell; it produces a sort of rolling sound, which lasts as long as the screw-post *B* is in connection with

the battery. Mr. Blavier thinks this bell apparatus a useful appendage to the Morse Telegraph, the sound of which can

Fig. 5.

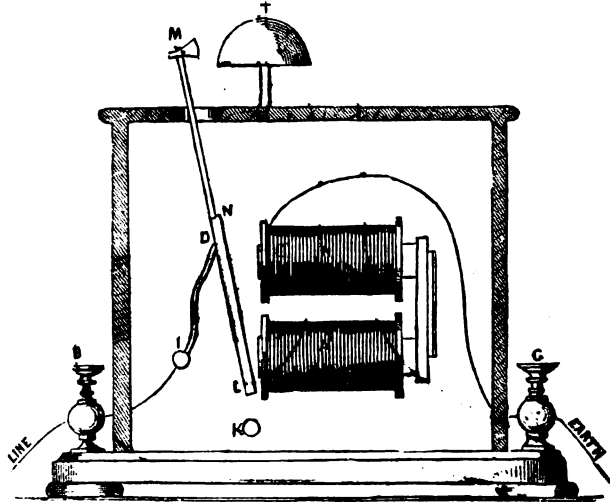

be distinguished, when given in adjusted time, to indicate the dots and dashes of the alphabet. The force of the hammer upon the bell depends upon the power of the electro-magnet in the attraction of the armature.

USE OF BELLS IN TELEGRAPH OFFICES.

In telegraph stations, where many lines centre, a special bell apparatus for each line is very common in Europe, in order that the operator may recognize the call of the respective stations on his line. A single bell apparatus suffices, if there is placed upon the circuit of each wire a relay, similar to that of the Morse apparatus. All these relays being furnished with an appendage, indicating the one which has been traversed by the current, closes the circuit of a local battery, and sets in motion the bell apparatus. This relay, fig. 6, comprises an electro-magnet A, and an armature, which, in a state of rest, touches the screw N, and when it is attracted, it touches the screw M. This screw M connects with one pole of the local battery, and the armature connects with the other pole, by means of the electro-magnet.

When the current is coming over the line, and traversing the electro-magnet *A*, the armature being attracted, makes the current of the local battery pass into the bell apparatus, and at the same instant disengages the rod *a b*, which rises under the action of the spring *d*.

Fig. 6.

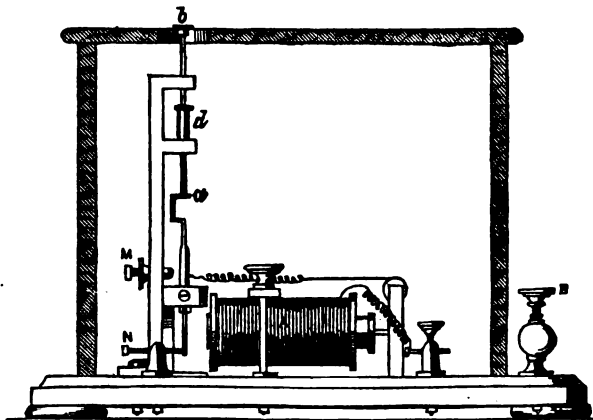

All the relays may be arranged in a single box, in order to save room. A single local battery being necessary, all the screws, such as *m*, communicate together, as well as all the armatures. Above each of them is written the name of the station with which it is in connection. For these bell apparatuses, relays must be employed, because they require a very considerable development of magnetic force, in order to produce a sufficient sound to be distinguishable.

In America, bells are wholly unnecessary on the Morse Electro-Magnetic Telegraph lines. They are serviceable on the House, Hughes, Barnes, and other printing apparatuses. On electro-chemical telegraph lines, bells are indispensably necessary. The ordinary relay magnet produces a sound, which, to the expert, is intelligible. On the German lines, sometimes bells are employed.

THE ELECTRO-CHEMICAL TELEGRAPH.

CHAPTER XXVII.

Bain's Electro-Chemical Telegraph—Apparatus and Manipulation—Smith and Bain's Patented Invention—Bain's Description and Claims—Morse's Electro-Chemical Telegraph—Westbrook and Rogers' Electro-Chemical Telegraph.

BAIN'S ELECTRO-CHEMICAL TELEGRAPH.

THE most prominent chemical telegraph is that of Mr. Alexander Bain, of England. There are none others in practical operation at the present time. In England, this telegraph is worked by the old Electric Telegraph Company to a limited extent. In the United States, through the wonderful energy of Mr. Henry O'Reilly, the chemical telegraph invented by Mr. Bain was used on an extensive range of lines about 1850. The Morse companies instituted suits, and obtained injunctions against the chemical telegraph lines, which produced a very great change in the use of that apparatus in America. The Federal Court for the District of Pennsylvania held a very thorough hearing on an application for an injunction, and a decree was awarded, declaring the patent which had been granted to Mr. Bain an infringement upon the original patent of 1840, granted to Mr. Morse.

After this injunction, the other chemical telegraph lines consolidated with the Morse companies. At the present time, there is but one electro-chemical telegraph line in America, and that one extends from Boston to Montreal, with branches; the whole making about 800 miles, and works in co-operation with the Morse lines.

THE APPARATUS AND MANIPULATION.

Having thus briefly referred to the present state of the chemical telegraph lines on both continents, I will, in the next

place, give a few explanations in regard to the practical manipulation of the apparatus.

Fig. 1 represents the apparatus placed upon a table ready for operation. The table is about four feet high and six feet long. The line wire enters the station upon the right, traverses

Fig. 1.

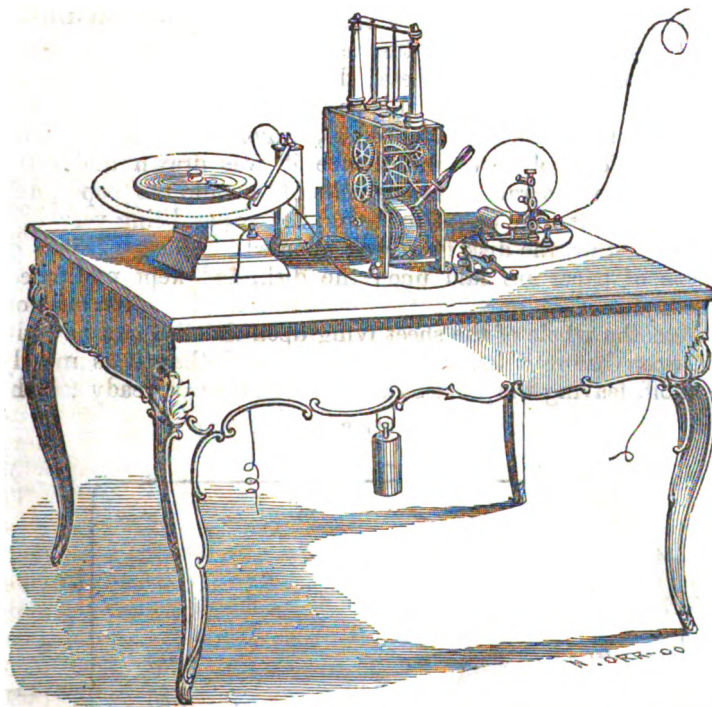

a small relay magnet, sitting on the right of the table; it then passes through the key, and thence to the stylus, which rests upon the disk; from beneath the disk, the wire is conducted to the earth.

The relay magnet upon the right has attached to it a circular piece of glass, which serves as a bell, when struck by a rod attached to the armature. With this, the call is made and the operator is thus notified when and by whom wanted. The clockwork on the centre of the table is to put in motion the disk, as seen upon the left. Upon the disk is laid the chemically prepared paper, which is kept damp. It lies on, or connects with the metallic disk. The stylus lies upon the moist paper,

and the revolving of the disk, when communication is being made, conducts the paper from under the stylus, so as to leave a clear space for the marks produced by the current of electricity. The line of dots on the disk illustrates the peculiar action of the marking by the stylus.

This form of apparatus was not universal. The clockwork seen in the table is about eighteen inches high, and is quite weighty. Some of the instruments are constructed as small as the Morse apparatus, using a ribbon paper, passing over rollers plated with a metal that will not be acted upon by the acids used to moisten the paper. The ribbon paper was drawn between two sponge rollers, which moistened it with the chemical solution, and thence it was drawn under the stylus. The operator was compelled to handle the paper, and in doing so, it was liable to break, the paper being very wet. To avoid this, the disk form was adopted. A dozen layers or sheets of paper are laid upon the disk, and kept moistened. The stylus is graduated to move from the exterior to the interior, so that the whole of the sheet lying upon the disk can be written upon before it has to be removed, and then it is merely torn off, leaving the next sheet clean and clear, ready for the

Fig. 2.

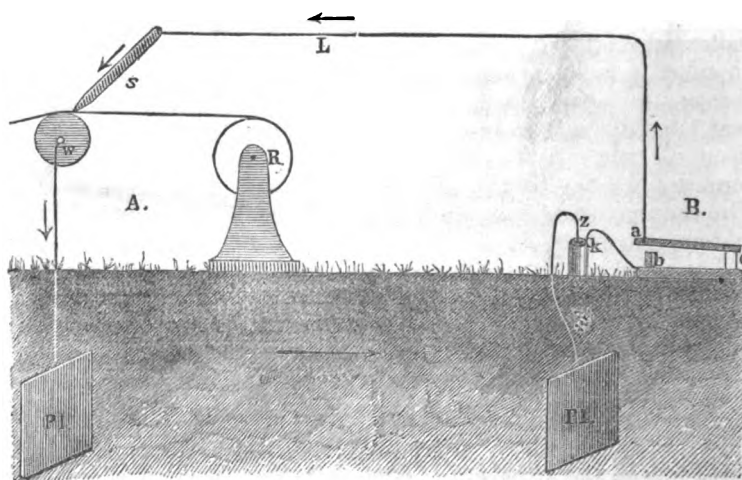

stylus to form the connection and trace the marks as before. The mark produced by the electric current does not extend farther than on the top sheet. The current passes through the other sheets leaving no mark. The coloring is confined to the place of contact between the stylus and the paper.

In order that the beauty and simplicity of this apparatus may be the better understood, I present a diagram of the electric current, which will be seen in fig. 2. *A B* are the respective stations. At station *B*, I introduce only the sending apparatus, and at station *A*, I leave off the sending mechanism, and insert only the receiving apparatus, reduced to the most simple and comprehensive form. I will first describe the sending station *B*. *P I* is the earth plate of zinc or copper, to which is attached a wire leading to the battery *z*; the wire *k* connects with the anvil *b* of the key *a b c*; to *c* is attached the lever *a*; *c* is a non-conductor, and insulates the brass pieces *a* from *b*; to *a* is attached the line wire *L*, which connects with the stylus *s*; *w* is a metallic roller, over which runs the chemically moistened ribbon paper from the reel *R*; from *w* the wire extends to the earth plate *P I* (station *B*).

The clockwork, as seen in fig. 1, is attached to the roller *w*, which puts in motion the paper, and causes it to move forward under the point of the stylus *s*.

In order to communicate, it is only necessary to press upon the lever *a*, which forms a contact with the anvil *b*. This then will complete the circuit from the earth plate of station *B* to the earth plate of station *A*, and the earth completes the circuit between the two plates. When the circuit is thus closed at *a b*, the electric current flows over the line wire, as indicated by the arrows, descends with the stylus, traverses the chemically moistened paper, passes through the roller *w*, and thence to the earth. In the passage of the electric current through the moistened paper, a beautiful dark color is left upon it, either in the form of a dot or a dash, as may be determined by the length of time that *a b* may be in contact. The manipulation with the key is the same as with the Morse system.

The color produced upon the moistened paper remains for an indefinite time. I have a strip of the paper that I got in London five years ago, and on reference to it on the present occasion, I find that the marks are as clear as they were when I got it.

It will be seen that, according to the arrangement of the circuit in fig. 2, there is no electric current on the line, unless a station is communicating, or, in other words, every station transmits a message with a current generated by the battery at that station. There will be, of necessity, a battery at every station. This arrangement, however, is not indispensable; for there might be a continuous current on the line, if desired. With a sounder at each station, there can be no impropriety

in the continuation of the voltaic current on the wire, as is the practice with the Morse apparatus in America. Some of the Bain chemical telegraph lines did not use the sounder for fear of an infringement on the Morse patents. Each station had an allotted time, and the batteries were so organized, that each station brought into service the battery of that station, communicating with that and none other.

With these explanations, I will now proceed to give Mr. Bain's descriptions and claims, in relation to his electro-chemical telegraph.

SMITH AND BAIN'S PATENTED INVENTION.

In the patent granted, in the United States of America, to Messrs. Robert Smith and Alexander Bain of England, under date of October 30, 1849, the inventors declare that their improvement in electro-chemical telegraphing consists of the following, viz. :

1st. In the present mode of arranging the several parts herein described of our marking instruments of Electro-Chemical Telegraphs.

2d. In a mode of constructing a style or point-holder, so as to afford a ready and convenient mode of regulating the pressure of the style or point on the surface of the chemically prepared paper, or other suitable fabric.

3d. In a mode of applying a weight for regulating the pressure of an upper on a lower revolving wheel, or roller, in motion, so as to grasp the strip of chemically prepared paper or other suitable fabric, and insure it being drawn continually forward.

4th. In a mode of arranging the marking instruments, keys, wires, and batteries, in a single circuit, and in branch circuits connected therewith, so that a copy of a message sent from any station may be marked upon the chemically prepared paper or other fabric, at any desired number of stations in communication therewith, and also, if required, at the transmitting station.

I would here state, that the paper, linen, or other suitable fabric, may be prepared by being equally and thoroughly moistened by the following chemical compound, viz. : Ten parts, by measure, of a saturated solution of prussiate of potash, which will be best made in distilled water, and we prefer to use the yellow prussiate for this purpose ; two parts by measure of nitric acid, of the strength of about forty by Baumé's scale ; two parts by measure of muriatic acid, of the strength of about twenty by Baumé's scale.

To keep the paper or other fabric in a sufficiently moist state, favorable for the action of an electric current, we add about one part by measure of chloride of lime; this mixture is to be kept stirred about with a glass rod, until the chloride of lime is in complete solution. In connection with this compound, it is proper to observe that we have found that prussiate of potash, combined with almost any acids, will give mark under the decomposing action of an electric current, but no other mixtures act so quickly, or give such permanent marks with feeble currents of electricity, as that herein described. The principal use of the chloride of lime is, that it absorbs moisture from the atmosphere, and thereby keeps the prepared fabric in a proper state to be acted upon by an electric current in all states of the weather.

After describing the apparatus for telegraphing, the following are given as the claims of the inventors:

1st. The modes of arranging the several parts of our marking instruments for electro-chemical telegraphs, substantially, as hereinbefore described.

2d. We claim the mode of adjusting a style or point-holder, as hereinbefore described and shown, so as to afford a ready and convenient mode of regulating the pressure of the style or point upon the surface of the chemically prepared fabric.

3d. We claim the mode of applying the weight *q*, for the purpose of regulating the pressure, as herein described and shown.

4th. We claim the mode of arranging the marking and transmitting instruments, wires, and batteries, in a single circuit, and in branch circuits connected therewith, so that a copy of a message sent from any one station may be marked upon chemically prepared paper, or other fabric, at one or any desired number of stations in communication therewith, and also, if required, at the transmitting station, without requiring the use of any secondary current.

In the application for a patent in the United States, Mr. Bain was opposed by Prof. Morse. The Commissioner of Patents sustained the claims of the latter gentleman. Mr. Bain appealed to the Federal Court for the District of Columbia. On the 13th of March, 1849, the honorable judge reversed the decision of the Commissioner of Patents, and issued the following order, viz.:

“And I do further decide and adjudge, that the said Samuel F. B. Morse is entitled, under the 7th section of the Act of 1836, to a patent for the combination which he has invented, claimed, and described in his specification, drawings, and model; and

that the said Alexander Bain is entitled, under the same section, to a patent for the combination which he has invented, claimed, and described in his specification, drawings, and model; provided the said Morse and Bain shall have respectively complied with all the requisites of the law to entitle them to their respective patents."

The following extracts were embraced in the application of Mr. Bain, which will be sufficient to explain the details of his telegraph.

BAIN'S DESCRIPTION AND CLAIMS OF HIS INVENTION.

Know ye, that I, Alexander Bain, formerly of Edinburgh, now of the city of London, at present in the city of New-York, electric telegraph engineer, a subject of the Queen of Great Britain, have invented and made, and applied to use, certain new and useful improvements in the construction of electric telegraphs, for which original invention a patent was granted to me, by the government of Great Britain and Ireland, dated, in London, the 12th of December, 1846, for which said original invention, including other original and important improvements thereon, I now seek letters patent of the United States: That the said improvements differ with all other precedent modes employed in electric telegraphs; first, by using electricity in a manner independent of any magnetic action; secondly, in composing a message or communication by perforations through paper, in sets of characters, each of which represents a letter of the alphabet, or numeral figure, or other needful sign; which arrangement of perforated signs being arbitrary, may be changed at pleasure, so as to transmit secret or other important communications, by signs not understood by those not having the key or index of the secret arrangement; thirdly, by an arrangement of mechanical means, through which the non-conducting substance of the paper passing through the electrically excited parts of the machinery interrupts the circuit, except when the perforated parts forming the signs pass between the electrically excited parts of the machinery, and place these in contact in a manner that completes the circuit, transmitting a corresponding electric pulsation to the receiving apparatus at the distant station; fourthly, in recording the pulsation so given, by the intermittently passed electric fluid, on chemically prepared paper in such a manner as permanently to record on the chemically prepared substance a succession of signs corresponding to the perforations in the paper used at the transmitting station; and, fifthly, in the arrangement of mechanical means, by which a communication, when composed, can be

simultaneously transmitted through one machine to any plurality of distant stations, at, or nearly at, the same instant of time; and, as will be shown hereafter, with a rapidity unknown in electro-telegraphic apparatus wherein magnetic influences are admitted.

Before describing the means of making the perforations to form the signs, it may be proper to describe the signs hitherto found most available. By referring to description, it will be seen that the letter A is formed by one small dot and a line, thus, - —; the letter B by a dot, a line and a dot, thus, - — -; and so on of the rest; but it will be seen that all the letters to N, inclusive, are begun with a dot or dots to the left of the line; L being formed by four dots, I by two dots, and E by one; all following are begun with a line to the left of the dot or dots used; the Y and Z with the abbreviation & being represented by lines only. The numeral signs to 5, inclusive, also commence with a dot or dots, and from 6 to 0, inclusive, these numerals begin with lines; the fractional line is represented by — - - - —, and is to be preceded by the numerator, and followed by the denominator of the given fraction, thus - - - - - — - - - - — - - - -, will represent $\frac{5}{9}$, and so on of all the other signs. It has been before noticed, that these signs are arbitrary and changeable; but as will be seen hereafter, the means of composing, transmitting, and recording signs are equally effective for any other system of signs that may hereafter be found either better in arrangement, or more especially applicable for any particular object.

The entire alphabet, as adopted by Mr. Bain, and used on the American lines, was the following:

ALPHABET AND NUMERALS.

A - —	N - - — —
B - — .	O —
C . . .	P — . .
D . . —	Q —
E .	R — — .
F — — — —	S — . .
G — . . .	T —
H — — —	U — .
I . .	V — — — — .
J . . . —	W — — . . .
K — — — .	X — . . . —
L	Y — —
M — — . . —	Z — — — —
	& — — — —

NUMERALS.

1	6
2	7
3	8
4	9
5	0

The process of rapid communication contemplated the previous preparation of the ribbon paper, by perforating the alphabet. This arrangement was as follows :

The punch is cylindrical, having a flat end and a sharp edge, and the whole of the parts very accurately fitted and adjusted together, without any lateral shake in the punch, so that it enters the die properly. When so completed, the compositor passes a strip of paper of any required length from beneath through the right-hand slot, and under the guide-block, out and downward through the left-hand slot, when the compositor strikes the head with a small ball of wood, covered with leather or India-rubber, in his right hand, which forces the punch point through the paper into the die, cutting out a small disk that falls through the die and holes below ; the expansive spring throws the punch up, while the compositor, by his left finger and thumb, draws the paper on, to strike successively again on the punch head at the required distance, which, for a second or next successive single perforation, should be equal to the diameter of one dot, the space between a dot and the commencement of a line the same ; to form a line, the compositor draws the paper on a little less than the diameter of a dot, successively, until he has struck the punch as many times as will form a line equal to three diameters of one dot, leaving a space between the ends and the commencements of lines, in the same manner equal to the diameter of one dot ; the space between each two letters, equal to four dots ; and the space between each two successive words equal to the diameters of eight dots. This process forms groups of perforations in a continuous line, each of which groups complete a sign, representing a letter or numeral, and the larger spaces show the ends and commencements of words, that so placed are formed and read from left to right along the centre of the paper, in the same manner as common writing or printing. In this manner, a competent compositor, with a thorough knowledge of the signs, will compose a communication nearly as fast as it can be set up in type, and as fast as the same quantity of matter can be marked upon paper, by magnetism operating through mechanical means. When all the perforations are made, the paper strip is to be wound on a

roller, which fits into the transmitting machine, so that the communication is ready to be passed through that machine.

In regard to the preparation of this paper for the application of the apparatus, the following will serve as explanatory :

To receive a communication, the wire brush is to be turned back to the right by means of the pointer, to be out of contact with the transmitting roller ; then take a piece of fine, good smooth paper, the width of which should be equal to the length of the cylinder, and long enough to go round the cylinder, with the ends lapping over each other a quarter of an inch ; this paper is to be previously prepared as follows : It is to be laid on any clean surface that acids will not act on, the paper is then to be covered on the upper surface with oil, by a very clean sponge ; for this good salad oil will answer, but other oils will answer, if they do not evaporate too quickly, because the use of the oil is to lessen the evaporation of the chemicals next noticed, by retaining their moisture ; the paper is then to be turned over, and washed with a clean sponge containing a solution of nitric acid, prussiate of potash, and liquid ammonia, in the following proportions—the ammonia is merely added to prevent the other ingredients from rotting the paper : Two parts, by measure, of pure nitric acid, twenty parts, by measure, of a saturated solution of prussiate of potash, in distilled water, and two parts of pure liquid ammonia, mixed together. The paper so prepared is to be laid, with the oiled surface upward, on and around the cylinder, and the lapping edges fastened with a little gum water ; the cylinder is then to be put in place, and the steel slide is to be turned on to the paper ; the apparatus is then ready to receive a transmitted communication. The machinery is then to be worked by a man at the wheel, at the rate of one revolution of the wheel per minute, the same as in transmitting a communication, and as before stated. The operator at any one distant station transmits the electric current in pulsations, regulated by the perforations in the paper he is using, as already explained, and these pulsations are received by the wire, as before mentioned, they pass by the screw and standards, axle, thence to the stem, and through that to the style, and through the chemically prepared paper to the cylinder, leaving a dark mark on the paper, which, though less in size, will be in number and position an exact transcript of the perforations in the paper used at the transmitting station. It is proper to notice, that steel styles leave a dark mark approaching black or blue black on the paper, but copper styles will leave a brown mark on the paper. It is not intended to discuss the theory of the causes that produce

these effects and facts ; nor is it intended to claim the use of any particular chemical solution, either separate or conjoined ; because the paper saturated with a solution of nitric acid only will receive a communication that will not become visible, until the paper is washed with a solution of prussiate of potash ; therefore any chemical solutions may be used that will produce the best effects ; and I have stated the solutions of nitric acid and prussiate of potash as those that I have hitherto found most effective in practical use.

It is believed to be sufficiently plain, without much explanation, that as the perforations composed in the paper successively pass under each comb, the electric circuit will be completed, by the points of the comb coming in contact with the roller through such perforation, and that a corresponding period of rapid electric pulsations will be thus communicated simultaneously to the marking style at each distant station. It is proper to remark, that the battery in connection with each transmitting roller, must be of proportionate strength to the distance the current has to travel ; and these arrangements admit of so graduating the strength of each battery, because each separate circuit is totally and entirely independent of any other circuit ; and each circuit is completed at the receiving station, independent of any other station, and the communication transmitted is received and recorded at each receiving station, in the same manner, and with the same effect, as if made with the single acting machine first described.

All other electric telegraphs hitherto used are dependent on the motive power of electro-magnetism for their action, and many mechanical means have been sought or tried, whereby to adapt this power for use, the main principle remaining the same in all ; the machines are, consequently, all designated " Electro-Magnetic Telegraphs."

But electricity travels with a velocity capable of giving several thousand signals per minute of time ; and any apparatus composed more or less of ponderous bodies, having also to give motion to other and similar bodies, cannot act with more than a fraction of the velocity with which electricity travels ; and another and greater hinderance is, that, however skilful an operator may be, he can only open and close the electric circuit, in a manner which again reduces the numerical velocity of its pulsations, and no other mode has yet effected the correct transmission of the same communication to a plurality of distant receiving stations.

I have, therefore, in my hereinbefore described invention, rejected magnetism altogether ; and caused the pulsations of the

electric current to be transmitted through groups of perforations, forming signs which are recorded at the receiving station by the pulsations of the electric current, acting on chemically prepared paper, in the manner described and shown; so that the circuit is completed and interrupted by the operation of the composed communication itself, without the electric current having to produce any mechanical motion, and without any manipulation of the operator, in forming the intermittent pulsations of the electric current, thereby effecting the transmission of a communication to one or a plurality of distant receiving stations, with far greater rapidity than by any other known mode.

It is not deemed requisite to describe or refer to the voltaic, or other source of electricity, nor is it intended to claim the application of that or any other electric source to these purposes; nor is it intended to claim any of the parts employed herein, irrespective of the uses to which they are severally put, as herein described.

But I do claim as new, and of my own invention, and desire to secure by letters patent of the United States:

1st. The composing of electro-telegraphic communications, by making groups of perforations through paper, corresponding with or representing the signs to be transmitted, irrespective of the general arrangement of the collective or individual signs, and irrespective of the mechanical means employed to make the perforations.

2d. The application of paper so perforated to open and close an electric current, or several successive currents, thereby transmitting the electric current or currents in successive pulsations, that correspond with the perforations in the paper, substantially in the manner described and shown; but including any merely practical or convenient variations of the mechanical means, or materials, or fabrics employed, that are analogous or equivalent in their operations and effects.

3d. The application of any suitable chemically prepared paper, without regard to the chemical ingredients used for such a purpose, to receive and record signs forming communications, such signs being made by the pulsations of the electric current or currents transmitted from a distant station, said current operating directly, and without the intervention of any secondary current or mechanical contrivance, through a suitable metal marking style, that is in continuous contact with the receiving paper, thereby making marks thereon, which marks correspond with the groups of perforations in the paper, composing the transmitted communication, or may be given by the pulsations from the spring and block, so that, in either

case, these form the received communications, substantially, in the manner and with the effects described and shown, including any merely practical variations in the means employed and the effects produced thereby.

MORSE'S ELECTRO-CHEMICAL TELEGRAPH.

In order that the chemical telegraph invented by Prof. Morse may be understood, I have taken the following extracts from his patent. This chemical telegraph has never been put into operation. The right is held by the companies owning the other Morse patents, and, whether better or worse, there is a disinclination to change the systems.

Whereas, among my earliest conceptions of the telegraph, in October of the year 1832, on board the packet-ship, *Sully*, on her voyage from France to New-York, I conceived the idea of marking the telegraphic signs I had invented (being dots and spaces to signify numerals), by electrical decomposition of certain salts and chemical compounds; and whereas, the application of the proper means for producing a successful result of this thought was soon after superseded in my mind by another method, at the same time conceived, of marking the said signs, to wit, by magnetism, produced by electricity, which is the successful method now in use, and having recently recurred to my original thought of applying decomposition by electricity through a single circuit of conductors, and discovered a means of successfully applying the same, as then conceived, to the marking of the aforesaid signs for numerals and letters, and of any desired characters, I will here describe the nature of my invention, and the method by which I obtain my results.

The nature of my invention consists: 1st. In the application of the decomposing effects of electricity produced from any known generator of electricity, to the marking of the signs for numerals or letters, or words, or sentences, invented and arranged by me, and secured by patent, bearing date June 20th, 1840, reissued January 15th, 1846, and again reissued June 13th, 1848, or their equivalents, through a single circuit of electrical conductors.

2d. In the mode of applying this decomposition, and the machinery for that purpose.

3d. In the application of the bleaching qualities of electricity to the printing of any desired characters.

In applying the decomposing effects of electricity upon any known salts that leave a mark, as the result of the said decomposition, I use

Class A.—A class of salts that produce a colored mark upon cloth, paper, thread, or other material; under the action of electricity.

1st. Iodide of tin in solution.

2d. Extract of nutgalls, and sulphate of iron, in solution, making an ink which colors white cambric cloth of a uniform gray.

3d. Acetate of lead, and nitrate of potash in solution.

4th. Iodide of potassium in solution.

Into either of these I dip a strip of cloth or thread, which is kept properly moistened. All these give a black mark upon the cloth, thread, or other material under the action of electricity.

Class B.—A class of salts which color the cloth, paper, thread, or other material, and are bleached by the action of electricity.

1st. Iodide of tin in solution.

2d. Iodine dissolved in alcohol.

Into either of these I dip a strip of cloth, paper, thread, or other material; and if in solution second, I also dip them into a solution of sulphate of soda, the cloth or other material, in these cases, becomes of a purple color more or less dark. The electricity in these cases, when a metallic point or type is pressed upon, or comes in contact with the moist cloth or other material, bleaches it, and leaves the point or the type impressed in white characters upon the material.

Class C.—A class of salts that produce a mark upon metal, through the intervening cloth or other material, and not upon the material, under the action of electricity.

1st. Sulphate of copper in solution.

2d. Chloride of zinc diluted with water.

3d. Sulphate of iron in solution.

Into either of these solutions I dip the cloth, thread, or other material, and if into the third, I afterward dip it into muriate of lime in solution. The electricity in these cases causes a dark mark upon a bright metal plate beneath the moistened material, but not on the material itself.

The mode of applying this decomposition by electricity, is by the use of so much of my machinery previously described in the schedule referred to in the letters patent, granted to me, and bearing date June 13, 1848, being the re-issue of the original patent of April 12th, 1846, as is employed in regulating the motion of the paper, substituting, however, for the common paper therein used, the cloth, thread, metal, or other material, chemically prepared, and which machinery is therein

described in the words following, to wit: "The register consists of a series of wheels and pinions, and its object is to regulate the movement of paper, or other material upon which to imprint telegraphic characters. *A, A, &c.*, sheet I., II., figs. 1 and 3, the platform of wood or other convenient material upon which the machinery is erected. *B B, &c.*, the standards for the reel of paper, and *c* the reel of paper upon which is to be printed the telegraphic characters. *D* one form of the arrangement of the wheels and pinions of the register; *a e* rollers for drawing the paper in contact with the pen or marking roller 2, seen also on sheet III., fig. 10. * * * * * The frame *D* contains the train of wheels, whose motion is caused by the weight *a*, or its equivalent. * * * * * The paper roller *d e*, and 2, fig. 10, sheet III., are so connected with the train of wheels, that the paper drawn from the reels by passing between *a* and *e*, is made to be in contact with the cylinder, fig. 2. The roller *e* is kept in contact with *a*, by the forked spring in fig. 10, bearing upon the ends of the journals, and regulated in its strength by the thumb-screws 8 and 9. The bearings or sockets for the ends of the shafts of *e*, are not circular, but are slots to allow of a slight movement in a direction with and against the force of the spring, so that the spring shall act with proper power, tending to keep the cylinder *e* in contact with *d*."

Instead of a magnet, however, and lever and pen, I dispense altogether with both the receiving magnet and the register magnet, of my former patents, and substitute therefor the following arrangement, as exhibited in the accompanying drawing and description:

Description.—In the accompanying drawing, *r* is so much of the register of my original patent just quoted, as is used in drawing and regulating the motion of the paper, and is similarly used for drawing and regulating the chemically prepared material for marking by electricity.

s s is the wooden platform for mounting the machinery.

a is a metallic cylinder or drum, or piece of metal mounted upon a metal standard *d*, screwed into the platform. *b* is the cloth or prepared material to be marked.

c is a thin-edged wheel, the periphery of which is platinum, held by a metal spring *e*, also mounted on a metal stand and *f*, screwed into the platform.

k is the metal key of my previously patented telegraph machinery. One form of it consists of a short lever of metal, having its fulcrum at or near one end. At the other end is a finger-knob, the better to press it down. Between the fulcrum and the knob may be a protuberance or hammer, as at *i*, above

a small anvil, as at *h*, from which the hammer is separated, when not pressed down, by a spring. *p* is the battery.

From the standard *d*, a conductor proceeds to one pole of the battery. From the standard *f*, a conductor proceeds connecting with the back of the key at *g*, which is screwed into the platform.

h is the metallic anvil, also screwed into the platform, and insulated from the rest of the key.

i is the hammer attached to the upper part of the key.

From the anvil proceeds a conductor to the other pole of the battery.

Operation.—While the hammer *i* is separated from the anvil *h*, no current can proceed from the battery. But the moment *i* and *h* are in contact, the current of electricity takes the direction of the arrows, and passes through the chemically prepared material at *a*, decomposing the salt with which it is prepared, and making a mark. Thus the characters of my conventional alphabet, and other characters, are at pleasure made upon the prepared material.

I consider the discoloring process better than the bleaching process; and for the discoloring process, I consider the iodide of potassium in solution, as the best of the substances I have mentioned for the preparation of the cloth, paper, or other material. I wish it to be understood, that I do not confine myself to the use of the substances I have mentioned, but mean to comprehend the use of any known substance already proved to be easily decomposed by the electric current.

Claims.—What I claim as of my own invention and improvement, and desire to secure by letters patent:

1st. The use of the single circuit of conductors for the marking of my telegraphic signs already patented, for numerals, letters, words, or sentences, by means of the decomposing, coloring, or bleaching effects of electricity, acting upon any known salts that leave a mark as the result of the said decomposition, upon paper, cloth, metal, or other convenient and known markable material.

2d. I also claim the combination of machinery as herein substantially described, by which any two metallic points or other known conducting substances, broken parts of an electric or galvanic circuit, having the chemically prepared material in contact with and between them, may be used for the purpose of marking my telegraphic characters already patented in letters patent, dated the 20th June, 1840; in the first issue 25th January, 1846; and second re-issue, 13th June, 1848.

WESTBROOK AND ROGERS' ELECTRO-CHEMICAL TELEGRAPH.

Messrs. Charles Westbrook and Henry J. Rogers, of the city of Baltimore, were extensively engaged in the chemical telegraph lines, and in their daily labors, they invented a very important improvement. The stylus, made of asbestos or other substances, is brought into contact with the brass disk, as seen in fig. 1. On passing the current through the stylus, a clear and distinct mark is made upon the brass plate. This mark can be removed by rubbing the face of the disk. They also devised the plan of using a fountain pen and other modes, to avoid the use of the chemically moistened paper.

As a practical telegraph, there can be no doubt but what the invention of Messrs. Westbrook and Rogers would prove eminently useful, and subserve completely the purposes intended. The dot and dash alphabet was employed.

In order that the reader may have a fuller description of this important improvement in telegraphing, I extract the following from the letters patent granted by the government of the United States to Messrs. Westbrook and Rogers :

The nature of our invention consists in recording telegraphic signs on a metallic surface, connected with the earth by a wire conductor at one end, and to a galvanic battery and the earth at the other end of the circuit, by the use of the acidulated water or other fluid interposed between the point of the usual wire conductor, leading from the operating apparatus, connected with a galvanic battery of the ordinary construction and the metallic surface, by which the use of paper is dispensed with ; time also being saved in not having to moisten the chemically prepared paper, when it becomes too dry for use, and in having the telegraphic signs more clear and distinct on the metallic surface than on the paper, and in avoiding the inconvenience arising from the fumes from the chemicals employed in preparing the paper, and evils arising from the corrosion of instruments, and annoyance to the operators in preparing and using chemical paper, and other inconveniences.

The metallic recording surface, after being filled and transferred, is simply cleaned, by the application of a sponge, or other soft substance, saturated with acidulated water.

Description.—A is the pen, made tubular, of some non-conducting substance, such as glass or ivory, open at both ends, and made tapering at its lower end, for containing a piece of sponge or other porous substance, through which the acidulated water, or other fluid passes to the metallic surface, on which the telegraphic signs are to be made—the bore of the pen being

sufficiently large to contain the requisite quantity of acidulated fluid. By reducing the outlet at the tapered end of the pen, the sponge or porous valve may be dispensed with. A very small barrel valve might be used to regulate the flow of the fluid, instead of the porous substance.

b is a short conducting wire, connected with the metallic stand *c*, or pen-holder *d*, and leading into the barrel of the pen *a*, and brought into immediate contact with the acidulated fluid in the pen—thus continuing the conducting line to the surface of the metallic cylinder or plate, so that the current from the galvanic battery can be made to pass from the metallic conductor through the acidulated fluid or saline solution, to the metallic surface of the plate or cylinder upon which the signs or marks are to be made. *e* is the binding screw for securing the main wire; *f* is the main wire connecting the receiving and transmitting stations; *g* is the fulcrum of the manipulator; *h* is the manipulator; *i* is the anvil of the manipulator;—*k* platina pole of a galvanic battery;—*l* is the zinc pole of the battery, connected by a wire with the ground plate *m* at the transmitting station;—*n* is also a ground plate, connected with the binding screw *e*, at the receiving station.

g is a horizontal stationary screw-shaft, upon which the cylinder moves to the right, by means of a chaser (*s*), fixed to the end of the cylinder, and revolving with the cylinder in contact with the spiral thread of said screw. The cylinder may be made to move to the right and to the left, over the shaft, simultaneously with its rotary motion, by forming a female screw through its centre, corresponding with the screw shaft. The rotary motion of the cylinder may be produced by ordinary clock machinery, or by a coiled spring, pulley, cord, and weight, or by any convenient means. The cylinder having the combined rotary and longitudinal movement, as aforesaid, will cause the telegraphic signs to be recorded on the surface of the cylinder or plate, in a continuous spiral line, in the same manner that we have practised for some time past.

Operation.—Bear down the long arm of the key, lever, or manipulator *h*, so that the point comes in contact with the anvil *i*, the current will instantly pass from the platina pole *k* of the battery, through the conducting wire and acidulated solution contained in the pen, to the surface of the cylinder (*c*) or plate (*p*), thence to the ground plates *m* and *n*, the earth being part of the circuit, and by the wire to *l*, the zinc pole of the battery, leaving a black mark or stain on the cylinder or plate, according to the length of time the circuit is closed,

indicating the sign, mark, word, or sentence required to be recorded.

Having thus described the nature of our invention and improvement in telegraphs,

What we claim and desire to have secured to us by letters patent is, recording telegraphic signs on the surface of a revolving metallic cylinder plate, or other equivalent surface, by means of an acidulated liquid, or saline solution, of water held between the point of the wire conductor and the metallic recording surface, by means of a non-conducting porous substance contained in a glass, or other non-conducting reservoir, in which the recording fluid is contained, to which the electric current from a battery is applied, by means of any of the known forms of manipulators, and anvils used for making and breaking the circuit—the recording fluid being applied to the metallic recording surface, substantially in the manner herein fully set forth, by which the use of every description of paper is dispensed with, thereby saving great expense in telegraphing.

FROMENT'S ALPHABETICAL AND WRITING TELEGRAPHS.

CHAPTER XXVIII.

Alphabetical Apparatus and Manipulation.—The Writing Apparatus.

THE ALPHABETICAL APPARATUS AND MANIPULATION.

THE alphabetical telegraph devised by M. Froment is distinguished for simplicity and peculiar construction of its transmitter or manipulating combination.

Fig. 1.

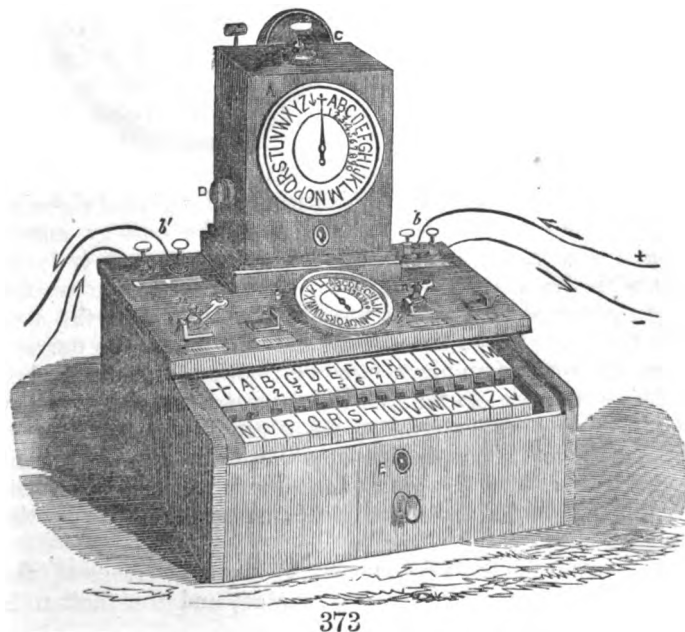

Figure 1 represents the instrument as seen in the station ready for telegraphing. It is an elegant piece of apparatus. In external form it resembles a small pianoforte without the black keys. There are twenty-eight keys: twenty-six of them representing letters, the twenty-seventh a cross, and the twenty-eighth an arrow; by pressing down any key its corresponding letter is shown on the dial, and at the same time on the dial of a similar apparatus at the distant station. Suppose, for example, the apparatus figured in the text to be at Paris, the current from the battery enters the apparatus at *b* and leaves it at *b'*; it proceeds thence to the distant station—say Rouen—where it traverses and works a precisely similar apparatus.

The mechanism of the internal part of the apparatus will be understood from a slight consideration of figs. 2 and 3.

Fig. 2.



Fig. 3.



Fig. 2 is the *manipulator*, or the instrument for giving signals; fig. 3 is the *receiver*. The current from the battery enters through *A*, fig. 2, passes up the brass spring *N*, which is in contact with the wheel *R*, and from this through the second notched spring *M*, out by the wire *B*, and on along the line wire to the telegraph at the distant station. There the current traverses the coils of an electro-magnet, not seen in fig. 2, but exhibited separately in fig. 4. This electro-magnet is fixed horizontally at one extremity, the other being left free to operate on the soft iron armature *a*, which forms part of a bent lever, moveable round the pin *c*; the lever is restored to a vertical position when the electro-magnet is no longer active by the action of the spring *r*.

The moment the electric current traverses the coils of the electro-magnet, the lever at *c* is attracted, and the motion is

imparted to a second lever *d*, through the shank *i*. This second lever is fixed on a horizontal axis, and is united to the fork *f*. When the current is interrupted the spring pulls back the lever, and thus a step by step movement is given to the fork, which it transmits to the wheel *c* carrying the index.

The manner in which the battery current is interrupted and renewed will be understood by referring to fig. 2. The wheel *r* carries twenty-six teeth; on turning it by the button *p* while the plate *n* is, from its curved form, in constant contact with the teeth, the plate *m*, being crooked, has its contacts broken and renewed every time it passes over a tooth and at the same time the battery current is thrown off and on. Suppose the pointer *f* is advanced four letters, then the current between *n* and *m* will be four times made and four times broken, and the armature of the electro-magnet at the distant station will be four times attracted and four times pulled back by its spring; but these four attractions will give four movements to the wheel *c*, and the pointer will pass over the same number of letters in the dial of fig. 3, the receiver, as in that of fig. 2, the manipulator. At the top of the case of the instrument is the alarum *c*, which is worked by a special electro-magnet. Referring now to fig 1, will be seen in front of the apparatus a series of twenty-eight ivory keys, the first marked with a cross, the last with an arrow; and the intermediate twenty-six with the letters of the alphabet, the first ten letters carrying also the ten numerals. Immediately in front of the keys, on a horizontal platform of mahogany, is the dial *b* and two small metal pieces, *m n*, which are moveable, and which by means of a handle may be brought into contact, *m* with *s* or *r*, and *n* with *q* or *p*. The dial *b* is the verifier; its index must always point to the same letter as that last signalled; if it does not, it shows that the apparatus is not in proper working order. When *m* is in contact with *s*, the apparatus is in a condition to send signals from Paris to Rouen. When in contact with *r*, it is in a condition to receive a signal from Rouen to Paris. In like manner when *n* is in contact with *q*, the alarum may be sounded at Rouen; when in contact with *p*, the machinery is in a state to receive a notice forwarded from Rouen.

As this apparatus is regarded of much importance, I will be more specific in its description than can be found elsewhere.

Fig. 4.

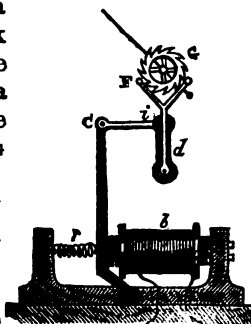

If the reader will carefully study the following descriptions and diagrams, he will not fail to comprehend the construction and manipulation of this beautiful system of telegraphing.

Fig. 5.

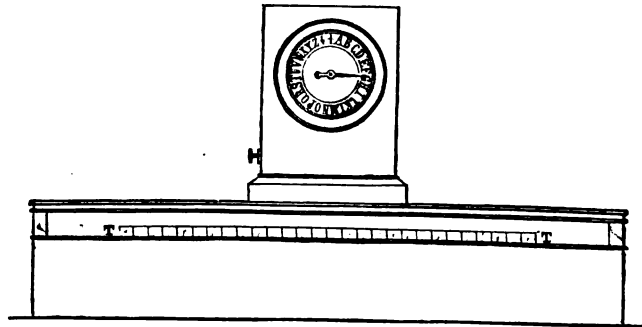

Fig. 5 represents an outline view of the front of the apparatus, as more fully shown by fig. 1. The key-board is indicated by $\tau \tau$.

Fig. 6.

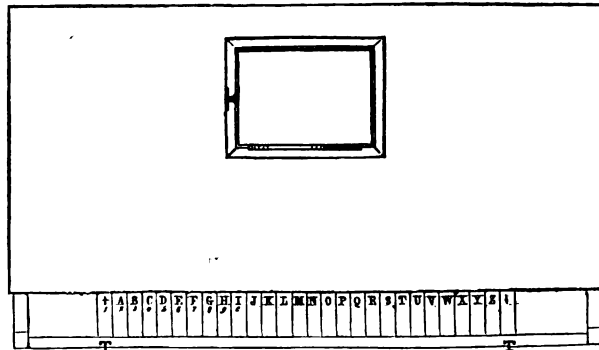

Fig. 6 shows a full view of the key-board $\tau \tau$, with the letters and numerals marked on the keys respectively. The key-boards, represented by figs. 5 and 6, are arranged different from the key-board of fig. 1. The two styles of instruments are used. Fig. 1 is more modern; but the arrangement shown in figs. 5 and 6 are also in operation. Operators exercise their own convenience in the use of the one or the other.

Fig. 7.

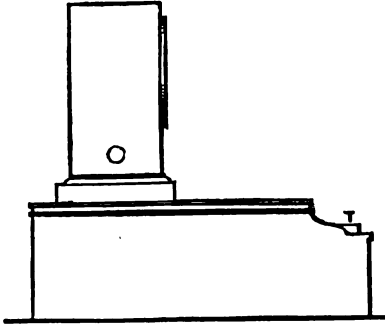

Fig. 8.

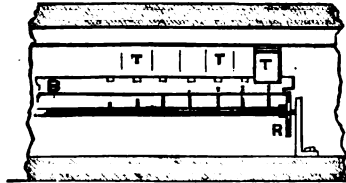

Fig. 7 represents an end view of fig. 1, and fig. 8 represents a section of the key-board $\tau \tau$, and the arrangement for the action of the keys. B is an elongated bar, and R is a wheel with a ratchet.

Fig. 9 represents a section of the key-board, as seen from above. $\tau \tau$ are the keys; B a bar traversing beneath the keys, as seen by the dotted lines, disengages the ratchet from the wheel R , and the releasement permits the arbor A to turn, until the pin answering to the key pressed. $z z z$ are pins upon the arbor A , as seen in the figure. $c c$ is a centre, around which moves the keys, which bear at their middle a stop pallet s , the use of which will be hereafter explained.

Fig. 9.

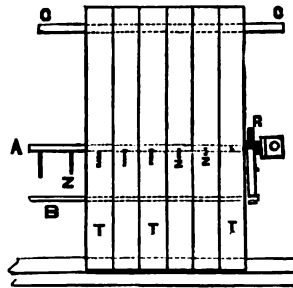
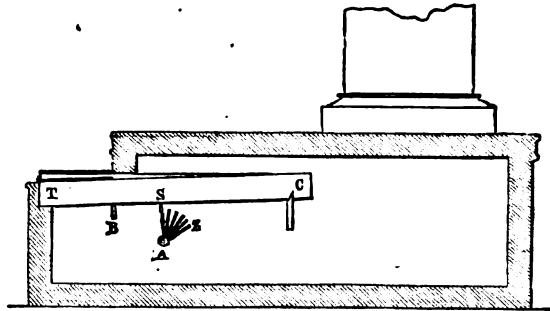

Fig. 10 is an end view of fig. 9, and shows the pallet s , the keys $\tau \tau$, the centre c , the pins $z z$, the bar B , and the arbor A .

Fig. 11 is another end view of fig. 9, having thereon the wheel R , and the ratchet attached to the arbor A . The arbor A , which is a horizontal bar, capable of being moved downward parallel to itself, is stopped in its movement by the ratchet, which engages in the wheel R . Whenever a key is touched, the bar A is lowered, and it rises when the finger is withdrawn. It is made to turn by means of a clock movement.

Another key may be pressed down, and there will be produced a similar effect, and the arbor A is permitted to turn

Fig. 10.



through an angle proportional to the length of the helix comprised between the two keys, which have successively stopped the movement.

Fig. 11.

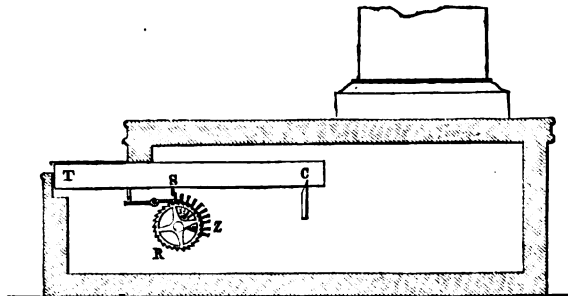

In this way, if the arbor *A* bears an electric interrupter, or circuit-breaker, which opens and closes the circuit every time that a tooth of the ratchet-wheel passes, the effect produced by this mechanism upon an electrical current, will be identical to that produced by the rotation of a telegraphic dial, having as many signals as there are keys in this apparatus, but with very perceptible advantages.

The rotations of the arbor *A* being uniform, are regulated according to the greatest velocity that the receiving apparatus is capable of executing. When a uniformity is once established, between the transmitting and the receiving apparatus, it will continue indefinitely to exist, independent of any irregularity in touching the keys; provided, of course, that the needle is allowed time to pass over the divisions of the dial, and this time

is extremely short, as the uniformity of movement permits of regularity for the greatest mean velocity of the receiving apparatus.

From these facts, it will be seen that any one knowing how to read, can transmit at first sight with this instrument a dispatch without an error resulting from the apparatus.

The clockwork of this instrument is wound up from time to time in the usual manner; but in addition to the care necessary to be observed in winding, the following mechanism has been attached. A fine-toothed ratchet wheel, fitted to the clock movement, and moved by a ratchet set in motion every time that the bar *b* is lowered, gradually winds up the spring of the clockwork, at a rate which has been found to be a little more rapid than the unwinding process of the clock movement. When the spring is wound up entirely, the ratchet ceases to act, because it is turned aside by a lever arranged for that purpose.

WRITING TELEGRAPH APPARATUS.

Mr. Froment also devised a printing telegraph, not employing the ordinary Roman letter, but signal letters. These letters were made by means of a pencil adjusted in mechanism, so that

Fig. 12.

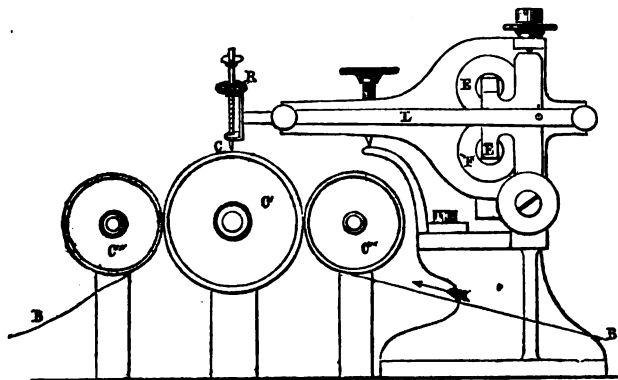

as the apparatus was put in motion by a clockwork, the pencil was sharpened and pressed upon the paper band, so as to make a clear and distinct mark. It was arranged at the end of the rod, fastened to the armature, as seen in figs. 12 and 13. In the three figures, 12, 13, and 14, the same letters indicate the same parts of the apparatus, and the reader may refer to each and to all for an understanding of the description herein given.

E E is an electro-magnet, and **L** is a rod attached to the armature, elongated to sustain the pencil **c**. **F** is the armature of soft iron. Immediately under the extremities of the armature **F** are the cores or the electro-magnets surrounded by the coils **E E**. **c** is the pencil writing on the ribbon paper **B**; **R** is a ratchet-wheel, which turns the pencil on its axis; **c'** is the cylinder upon which the ribbon paper **B** is rolled, and **c'' c'''** are cylinders regulating the movement of the ribbon paper **B**.

Fig. 13.

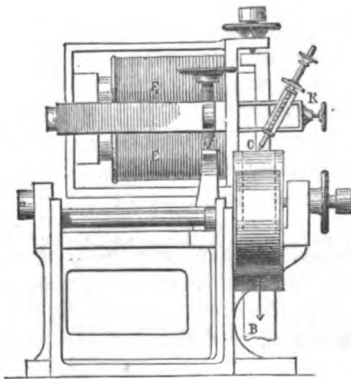

The apparatus is made to move by clockwork.

The practical operation of this apparatus is as follows: When the current is on the line, the electro-magnet attracts the armature, which causes the pencil to make a mark across the ribbon paper **B**; and as the paper

Fig. 14.

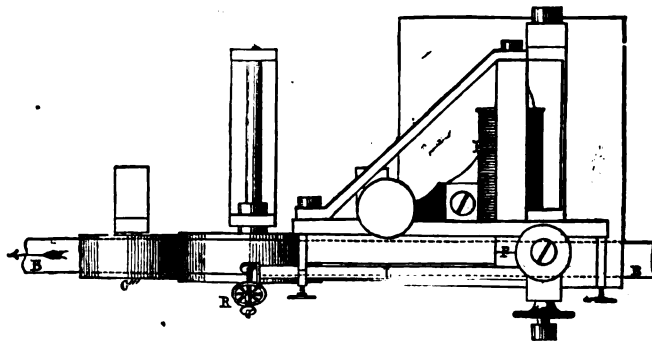

is in motion, the mark will be made at an angle in proportion to the speed of the paper passing over the cylinder **c'**. When the circuit is broken, the pencil will make a mark back to its normal position, regulated by a spring. A movement forward and another backward will make the letter **V**. If the manipulation is continued, by opening and closing the electric circuit, or by transmission or non-transmission of the voltaic current, the writing executed by the pencil will be as follows, viz.:

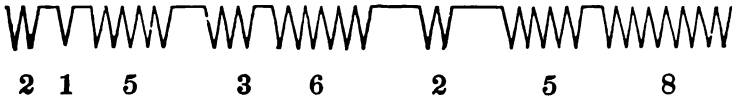

These points may indicate letters or numerals to be compounded and explained by a vocabulary. Thus, 215—36—2—58, may mean,

215 36 2 58.
 Froment's Practical Printing Telegraph.

The writing thus produced is clear, and easily to be read. The apparatus is simple, and not liable to get out of order. Fig. 15 gives a perspective view of the same. *A* is the frame upon which the parts are fastened; *B* is the bell apparatus and

Fig. 15.

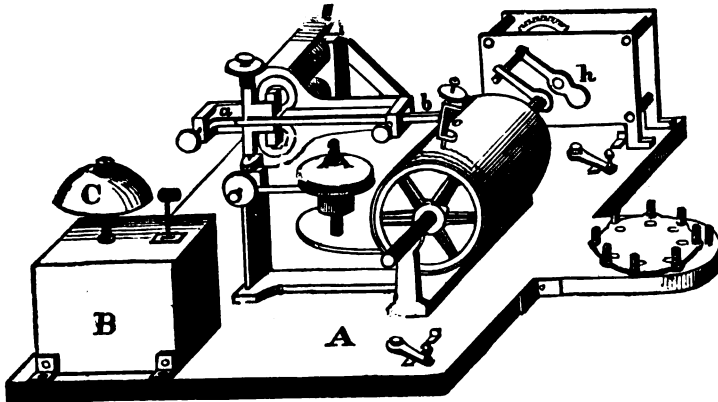

c is the bell; *h* is the clockwork, *a b* is the armature and pen lever, and *c* is the roller, upon which is fixed the paper. The current passes through the electro-magnet, attracts the armature, and thus motion is given to the pen point, which, being on the paper, the marks are produced.

VAIL'S PRINTING TELEGRAPH.

CHAPTER XXIX.

Description of the Telegraph Apparatus—Manipulation and Celerity of Communicating—Arrangement of the Alphabet.

DESCRIPTION OF THE TELEGRAPH APPARATUS.

IN September, 1837, Mr. Alfred Vail, of the United States, invented a printing telegraph. The following is his description of the apparatus :

Fig. 1 represents a front and side view of the instrument ; fig. 4 is a top view ; fig. 5 is a back view. The same parts are represented by the same letters in the three views. In fig. 1, *q* *q* is the platform upon which the whole instrument is placed. *m* and *m* are wooden blocks supporting parts of the instrument. *k* is the helix, the soft iron bar *n* passing through its centre, and there is another coil and bar directly behind this ; the two making the electro-magnet. *g* is its armature fastened to the lever *F F*, which has its axis at *r*, seen in fig. 4, at *x x*. *r* is a brass standard for supporting the lever *F* upon its axis, by means of two pivot-screws ; *a* and *a* are two screws passing vertically through the standard *r*, for limiting the motion of the lever *F F*. *j* is a spiral spring, at its upper end, fastened to the lever *F F*, and at its lower end passes through the screw *l*, by which it is adjusted so as to draw the armature from the magnet, after it has ceased to attract, and for other purposes, hereafter to be explained. *n o* is a brass frame, containing the type-wheel *B'* and the pulley *E U*. *p* and *p* represent the edge of a narrow strip of paper, passing between the type-wheel and pulley *E*. *d* is the printer, which, at the bottom, forms a joint with the end of the lever *F* and *r*. *b* represents twenty-four metallic pins, or springs, projecting at right angles from the side of the type-wheel ; each pin corresponding in its distance from the centre of the type-wheel to its respective hole, represented by dots upon the index *c* ; so that, if the pin is put in any one of the holes, the

type-wheel, in its revolution, will bring its corresponding pin in contact with it.

There are 24 holes, corresponding to the following letters of the alphabet: A B C D E F G H I J K L M N O P Q R S T U V W X, and

Fig. 1.

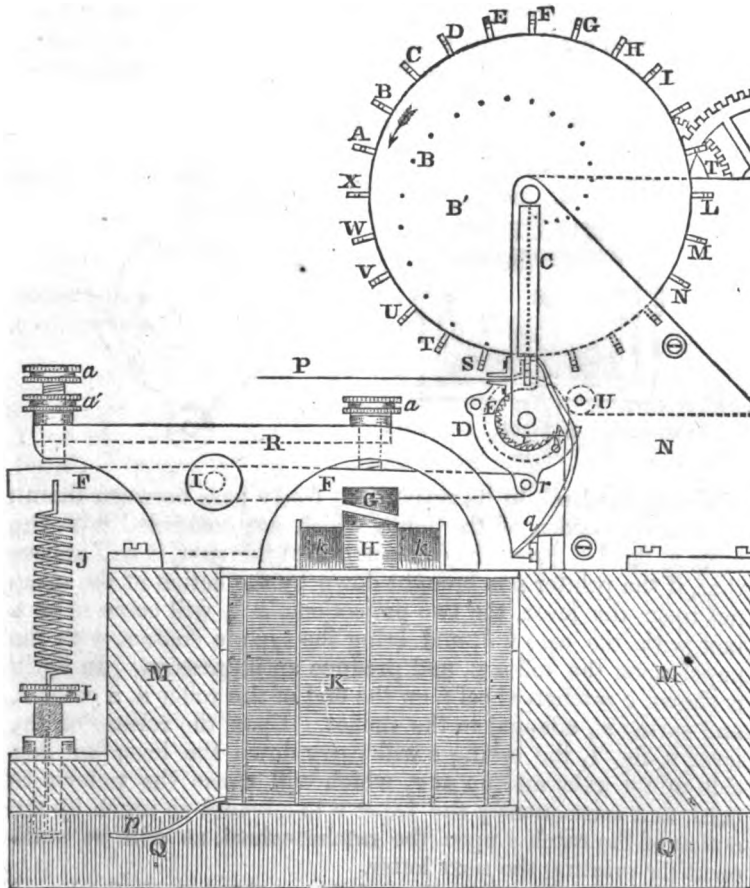

the types are lettered accordingly. The cog-wheels, *r* and *s*, are a part of the train of the clock. The lever *F F* has two motions, one up and another down, and both are employed by an attachment at the end of the lever *r*, and in the following manner: figs. 2 and 3 represent a front and end view of the roller *ε* and printer *D*, enlarged. *D* is the printer, fig. 2, of the form shown by *D*, fig. 3. *ε* is the roller over which the paper

p is carried. *A* is the front of the type, having ears, *h h*, projecting from each side. Through the sides of the printer *D D*, a rod, *u*, passes, in order to give more firmness to the frame. The rod projects a little on each side of the frame at *J J*. These projections slide in a long groove in the frames *n* and *o*, fig. 1, by which the printer is kept in its position, and allowed freely to move up and down. It will be observed that the upper parts of the frame *D D* extends over the top of the roller *E*, and nearly touch each other, but are so far separated, as to let the type *A*,

Fig. 2.

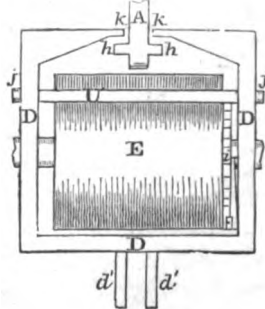
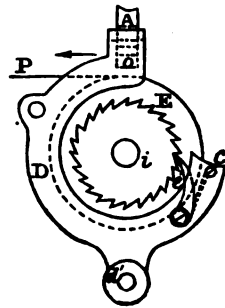

Fig. 3.



of the type-wheel, in its revolution, freely pass between them; *d' d'* are the sides of the joint, which are connected with the lever *F*, fig. 1. From the construction of this part, it will appear that, if the printer *D* is brought down by the action of the magnet upon the lever, the two projections, *k k*, will come in contact with the ears *h h*, and bring the type in contact with the paper upon the roller *E*, and produce an impression. In fig. 3 is shown a ratchet-wheel *i*, on the end of the roller *E*, a catch *e*, and spring *c'*, adapted to the ratchet. Upon the release of the lever *F*, fig. 1, the spring *J* will carry down the lever on that side of its axis, and up at *r*, which will cause the roller *E* to turn, and consequently the paper *P* to advance so much by the action of the catch *e* upon the ratchet-wheel, as will be sufficient for printing the next letter.

Fig. 4 represents a top view of the machine: *s* is the barrel upon which is wound a cord, sustaining a weight which drives the clock-train, and upon the same shaft with it is a cog-wheel driving the pinion *m* on the shaft *τ*; and on the same shaft *τ* is another cog-wheel, driving the pinion *n* of the type-wheel shaft *τ'*. *κ* and *κ* are the helices of the large magnet, of which *η* and *η* are the soft iron arms. *Μ Μ Μ Μ* are the blocks which support the instrument. *F F* is the lever, *a* and *a* its ad-

justing screws; x and x its axis; k and k are the two upper coils of the two electro-magnets at the back part of the instrument for purposes hereafter to be described; x is the wire soldered to the plate buried in the ground; p is the wire proceeding to the battery; c is the connecting wire of the two

Fig. 4.

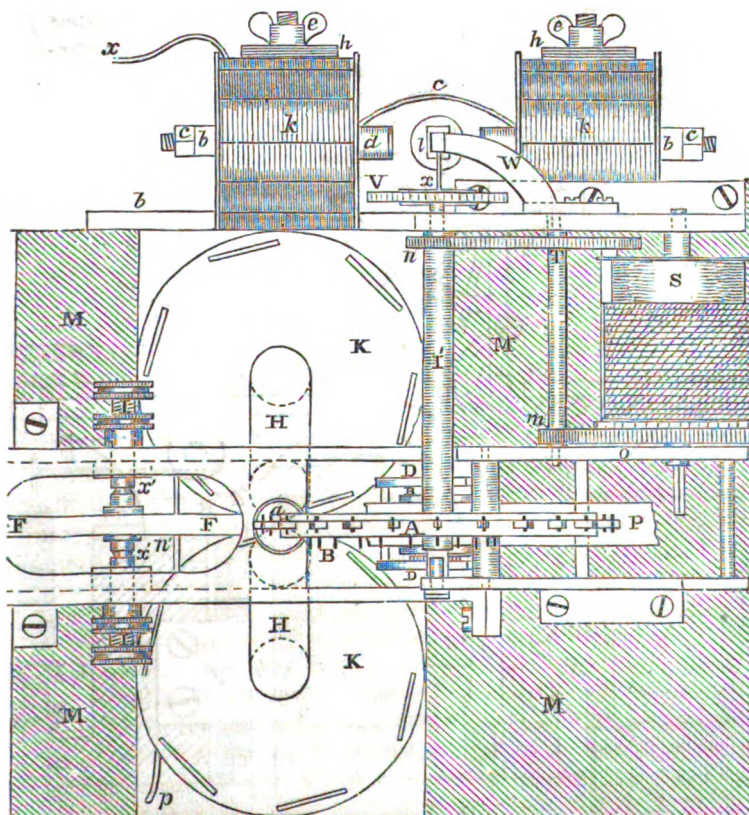

electro-magnets, $k k$; w is the support of the pendulum; v is the escapement-wheel; l is the type-wheel; $D D$ is the printer, and B the roller over which the paper P is carried.

Fig. 5 represents a back view of the instrument; $k k$ and $k k$ are the coils of two electro-magnets, surrounding the soft iron bars $d d$ and $d d$; b and b are the flat bars through which $d d$ and $d d$ pass, and are fastened together by the screw nuts $c c$ and $c c$. The right hand electro-magnet is fastened to the blocks

m and m , by the support f and f , from which proceeds a bolt passing between the coils k and k , and the block h , with a thumb-nut upon it, by which the whole is permanently secured. In the same manner the left-hand magnet is secured to the block

Fig. 5.

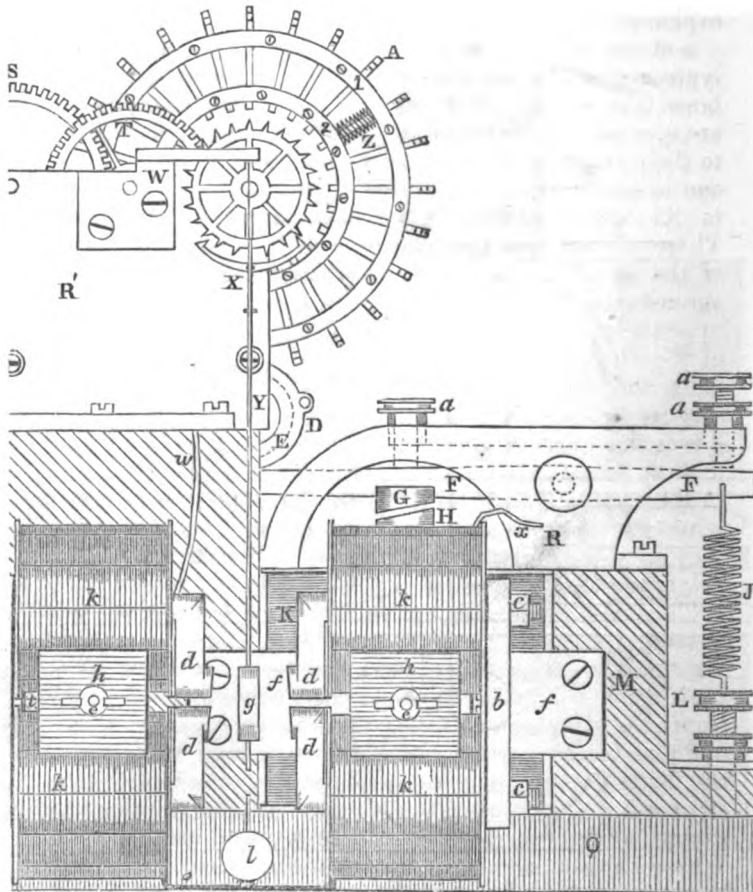

m . r' is the outside portion of the brass frame containing the clockwork. w is a standard fastened to r' , for supporting the pendulum y . x y and l are parts common to a chronometer for measuring the time, viz., the escapement and pendulum. The escapement-wheel has 24 teeth, corresponding in number with the type on the wheel, and such is the arrangement of the parts, that when the pendulum is upon the point of return,

either on the right or left hand, a type is directly over the paper, and the armature g is near the face of one or the other of the magnets; so that, if an impression is to be made with the type thus brought to the paper, the pendulum v is ready to be held by the magnet at the same time from making another swing, until the type has performed its office, which will be hereafter explained.

A shows the type as they are arranged on the wheel. The types are square, and move freely in a groove cut out of the brass type-wheel. At 1 and 2 are seen flat brass rings, which are screwed to the wheel, and over the types, confining them to their proper places. z is a spiral spring, of which there is one to each type, by means of which the type is brought back to its former position, after it is released by the printer. Through each type there is a pin, against which the inner end of the spiral spring rests. The outer end of the spring rests against the circular plate. w represents the wire from the upper helix, soldered to the metallic frame κ' . The two helices of the left-hand magnet are joined together, and from the bottom helix the wire proceeds to the lower coil of the right-hand magnet. These two helices are likewise connected, and the wire leaves the upper coil at x . Thus the wire is continuous from w to x . From x the wire is continued to a copper plate buried in the earth. The frame κ' , being brass, the arbor of the type-wheel and the wheel itself, and each being in metallic contact, they answer as a continuous conductor with the wire w , for the galvanic fluid.

The index c , fig 1, is insulated from the frame n , being made of ivory. There is inserted in the ivory a metal plate, containing the holes, to which is soldered a wire q , connected with the back coil κ . The two helices being connected, the wire of the front helix comes off at p , and thence is connected with one pole of the battery; from the other pole it is extended to the distant station, and is there connected with a similar instrument. It will be observed that the circuit is continuous, except between the type-wheel and the metal plate in the ivory. When neither station is at work, the batteries of both are thrown out, and their circuits, retaining in them the magnets of both stations, are closed. For this purpose, there is an instrument at each station, resembling in some respects a pole-changer. If one of the stations wish to transmit by reversing his circuit instruments, the battery is instantly brought into the circuit. Through the agency of the clock-work and weight, and the pendulum, both instruments are vibrating together, and their type-wheels are so adjusted, that when a type of one sta-

tion is vertical, the *A* type of the other station is also vertical. Now, suppose one station wishes to transmit to the other, the word *Boston*, for example; he first brings his battery in the circuit, then places a metallic pin in the hole of his index, *c*, marked for the letter *B*. When the type-wheel shall have brought round the pin corresponding to the type *B* on the wheel, its pin will come in contact with the inserted pin of the index, and instantly the circuit is established. The fluid, passing through the coils of the magnets, on each side of the pendulum, will hold it, and also passing through the coils *K*, will bring down the lever *F F*, and with it the printer *D*, which, as heretofore described in figs. 2 and 3, will bring the type with considerable force against the paper. The instant the two pins have come in contact with the moving-pin, it is taken out and put in the hole *o*, when the same operation is performed, and in like manner for the remaining letters of the word. The pin can be so arranged, as to be thrown out the instant a complete contact is made.

MANIPULATION AND CELERITY OF COMMUNICATING.

The rapidity of this printing process would be as follows: Suppose the pendulum makes two vibrations in a second, that is, it goes from right to left in half a second, and returns in half a second. Since, then, a single letter is brought to the vertical position, ready to be used if needed, at the end of each vibration, it is clear that the two letters are brought to the vertical position every second, or 120 every minute. This is not, however, the actual rate of printing; for, in the word *Boston*, the type-wheel, after *B* is printed upon the paper, must make so much of a revolution as will bring the letter *o* to the paper. This will require 12 vibrations of the pendulum; *s* will require 4; *t* 1, *o* 18, and *n* 22; equal to 57, to which add 6, the time required to print each letter, will make it 63. This, divided by 2, gives $31\frac{1}{2}$ seconds, the time necessary to print 6 letters. If we now take an ordinary sentence, and estimate in the same manner the time required to print it at the distant station, we shall be able to find what number of letters it can print per minute. As an example, viz.:

“There will be a declaration of war in a few days, by this government, against the United States. Orders have just been received to have all the public archives removed to Jalapa, which is 60 miles in the interior, for safekeeping.”

Here are 184 letters, and would require 2,266 vibrations, to which add 184, the number of letters, would give 2,450 half seconds, equal to 1,225 seconds, the time required for printing

the message; or over 20 minutes; the rate being six and two thirds seconds for each letter.

If, however, a vocabulary is used, with the words numbered, and instead of using the 26 letters of the alphabet on the type-wheel, we substitute the 10 numerals, in their place, we reduce the time required for a revolution of the wheel, and it is clear that this same message may be transmitted in much less time.

The following numbers represent the words of the same message, in the numbered vocabulary: 48687, 54717, 4165, 1, 12185, 34162, 54078, 25393, 1, 18952, 11934, 6177, 48766, 21950, 1106, 48652, 51779, 46532, 34475, 22991, 28536, 4321, 40254, 49085, 22991, 1391, 48652, 39087, 3845, 41278, 49085, 28536, 54536, 28668, 45008, 31634, 25393, 48652, 27326, 19865, 42813, 28592. Here are 42 numbers and 196 figures. To 196 add 42, the spaces required, and we have 238 impressions to make, to write the sentence thus represented. By calculation, we find there is required, in order to bring each numeral and space in its proper succession to the vertical position, 1627 vibrations of the pendulum, which, at the rate of two to the second, gives the time required to transmit the message at 812 seconds, or nearly 13 minutes, being at the rate of $18\frac{1}{3}$ letters per minute.

If, however, the vibrations of the pendulum are increased at the rate of 4 in a second, then the time required for the transmission of the message would be almost 7 minutes, and at the rate of $36\frac{2}{3}$ letters per minute. If it be increased to 6 vibrations per second, then the time would be $4\frac{1}{2}$ minutes, and at the rate of 55 impressions per minute.

ARRANGEMENT OF THE ALPHABET.

The modes of using the English letter for recording telegraphic messages are various. Among them are those using 26 types, one for each of the letters of the alphabet, and 13 extended wires, from station to station, with more or less battery. These types are arranged in a row, directly over the paper which receives the impression, and consequently require a strip of paper some 4 or 5 inches broad. Each type is furnished with an electromagnet and lever, answering as a hammer to bring down the types upon the paper. As the types are arranged in a straight line, they present the order given on the next page. In this example, we have the style of this kind of printing. By spelling the letters on the first line, then on the second, and so on, the words "Printing Telegraph" will be made out. Those letters which follow each other in the word, and also follow each other

THE HOUSE PRINTING TELEGRAPH.

CHAPTER XXX.

Early History of the House Telegraph—The Composing and Printing Apparatuses—The Axial Magnet—The Air Valve and Piston—The Manipulation—The Patented Claim.

EARLY HISTORY OF THE HOUSE TELEGRAPH.

THE printing telegraph invented and patented by Royal E. House is one of the most remarkable blendings of the arts and sciences accomplished by the genius of man.

In the perfection and introduction of his telegraph, Mr. House had to contend with the most extraordinary difficulties. Before him were the earlier patented systems, and it required wonderful powers to devise mechanical contrivances to act conjunctive with the known discoveries in the sciences. He obtained a patent from the United States government in 1848, dated from April 18th, 1846. This patent, however, was defective in the protection of a complete system. Early in 1847, Mr. Henry O'Reilly, the indomitable pioneer in telegraphing, became interested in the House Printing Telegraph, and he rendered invaluable aid in the perfection of the apparatus. This energetic and sterling telegrapher furnished the necessary means for new instruments, and had them applied to his line between Cincinnati and Louisville, in the fall of 1847. The first dispatch ever transmitted over a telegraph line with a printing system was by Mr. O'Reilly, from Cincinnati to Jeffersonville, opposite Louisville, 150 miles.

For a long time the friends of the House telegraph struggled against competing interests. Finally, in March, 1849, the first line using the House system was put in operation, from Philadelphia to New York. Under the able and enterprising administration of Messrs. Hiram Sibly, Francis A. Morris, R. W. Russell, and others, the House telegraph was rapidly and successfully extended to different parts of the country.

The mechanism of the apparatus operated with the most

perfect accuracy, and many of the instruments have operated for years with but little repair. I have recently seen one of them that had been used to so great an extent, that the fingers of the operator had worn away the ivory on the keys.

The main constituents of his telegraph are, the composing machine, the printing machine, a compound axial magnet, a manual power which sets the two machines in motion, and a letter-wheel or tell-tale, from which messages can be read, should the printing machine get out of order.

THE COMPOSING AND PRINTING APPARATUS.

A composing and printing machine are both required at every station; the printing apparatus is entirely distinct from the circuit, but all the composing machines are included in and form part of it: the circuit commences in the voltaic

Fig. 1.

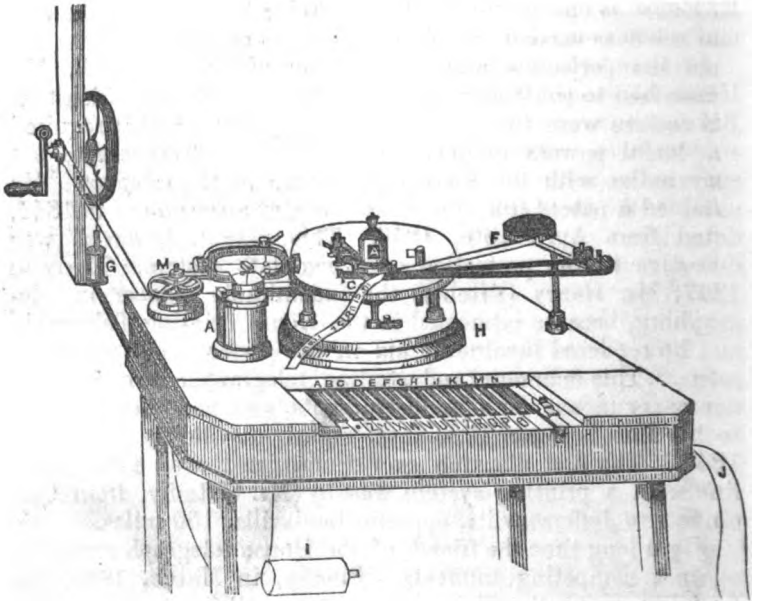

battery of one station, passes along the conductor to another station, through the coil of the axial magnet, to an insulated iron frame of the composing machine, thence to a circuit wheel revolving in this frame; it then enters a spring that rubs on the edge of this circuit wheel, and has a connection

with the return wire, along which the electricity goes through another battery back to the station from which it started, to pursue the same course through the composing machine and magnet there, and all others upon the line; thus the circuit is confined to the composing machines, axial magnets, conducting wires, and batteries.

The composing machine, fig. 1, is arranged within a mahogany frame *H*, three feet in length, two in width, and six or ten inches deep; the various parts of the printing machine are seen on the top of the same case; both are propelled by the same manual power, which is distinct from the electric current; it is simply a crank, with a pulley carrying a band to drive the machine, and a balance-wheel to give stable motion; one of the spokes of the balance-wheel has fixed to it an axis for the end of a vertical shaft to revolve on, that moves the piston of an air condenser *G*, fastened to the floor; the air is compressed in the chamber *I*, fourteen inches long, and six in diameter, lying beneath the mahogany case *H*; it is furnished with a safety-valve, to permit the escape of redundant air not needed in the economy of the machine.

Fig. 2.

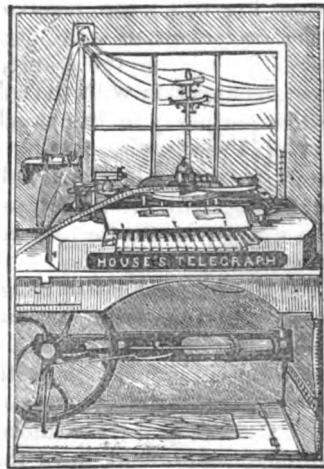

The composing system has an insulated iron frame, *A*, fig. 3, placed immediately below the keys, parallel with the long diameter of the case; this has within it a revolving shaft

Fig. 3.

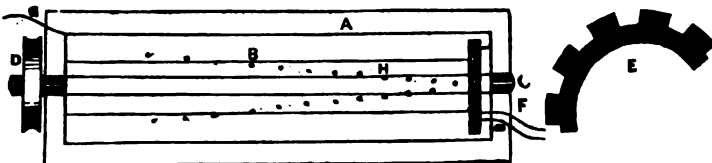

c; the shaft is enclosed for the greater part of its length by the iron cylinder *B*; it is made to revolve by a band playing over the pulley *D*, fixed to the left extremity of it. The cylinder *B*, fig. 3, is detached from the shaft, but made to

revolve with it by a friction contrivance, consisting of a brass flange fastened permanently to the revolving shaft; the face of the flange and the inner face of the circuit wheel are in contact with a piece of cloth or leather interposed, moistened with oil; the friction is regulated by a spring pressing against the end of the revolving shaft *c*.

The object of this friction apparatus is to allow the shaft to revolve while the cylinder can be arrested.

On the right end of the cylinder is fixed the brass wheel *e*, fig. 3, four or five inches in diameter, called the circuit wheel, or break; the outer edge of it is divided into 28 equal spaces, each alternate space being cut away to the depth of one fourth of an inch, leaving fourteen teeth or segments, and fourteen spaces, Fig. 3, *e*; the revolving shaft and cylinder form part of the electric circuit; one point of the connection being where the shaft rests on the frame, the other through a spring *f*, having connection with the other end of the circuit, pressing on the periphery of the break-wheel *e*, fig. 3; *g*, the other part of the circuit, coming from the axial magnet to the frame *a*; when the shaft, cylinder, and circuit wheel revolve, the spring will alternately strike a tooth and pass into an open space; in the former case, the circuit is closed, in the latter it is broken.

For the purpose of arresting the motion of the circuit wheel and cylinder, the latter has two spiral lines of teeth *h*, fig. 3, extending along its opposite sides, having fourteen in each line, making 28, one for each tooth, and one for each space on the circuit wheel; the cylinder extends the whole width of the key-board above it; the latter is like that of a pianoforte, containing twenty-eight keys that correspond with the twenty-eight projections on the cylinder, and have marked on them in order, the alphabet, a dot, and dash, fig. 1; they are kept in a horizontal position by springs; there is a cam or stop fixed to the under surface of each key; directly over one of the projections on the cylinder; these stops do not meet the teeth unless the key is pressed down, which being done the motion of the cylinder is stopped by their contact; by making the circuit wheel revolve, the circuit is rapidly broken and closed, which continues until a key is depressed; that key being released, the revolution continues until the depression of another key, and so on; the depression of a key either keeps the circuit broken or closed; as it may happen to be at the time, so that the operator does not break and close the circuit, but merely keeps it stationary for a moment; from one to twenty-eight openings and closings of the circuit take place

between the depression of two different keys or the repetition of the depression of the same one; the object of the composing machine is to rapidly break and close the circuit as many times as there are spaces from any given letter to the next one which it is desired to transmit, counting in alphabetical order.

THE AXIAL MAGNET.

The rapid electrical pulsations are transmitted by the circuit of conductors to the magnet and printing machine at another station, through the wire *J*, fig. 1. The helix of this magnet is an intensity coil contained in the steel cylinder *A*, fig. 1, on the upper surface of the mahogany case; its axis is vertical.

A, fig. 4, is a brass tube, eight or ten inches long, placed within the helix, and fastened at the bottom by the screw *p*. To the inner surface of this tube are soldered six or eight soft iron tubes, separated from each other at regular intervals. Above the iron cylinder is an elliptical ring *F*, through the axis of which is extended an elastic wire, *g*; two screws are attached to the wire, by which it is made lax or tense, to suit the intensity of the electric current. From this is suspended the brass rod *c*, that passes down within the small iron tubes before mentioned, and has strung on it six or eight small iron tubes *L*; these are fastened at equal intervals, and have their lower extremity expanded into a bell-like flanch; the surrounding fixed ones have their upper ends

Fig. 4.

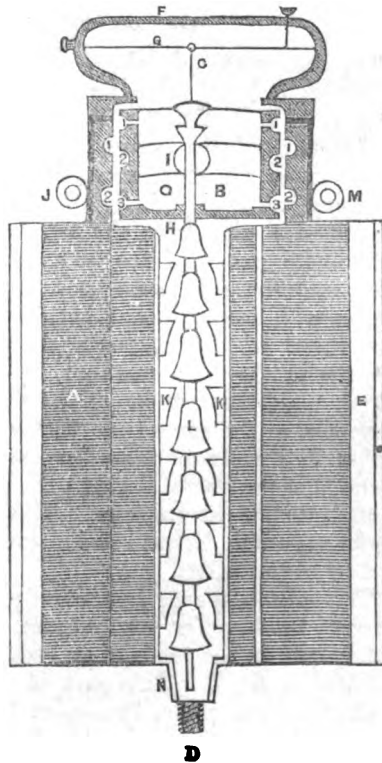

enlarged inwardly in the same manner. The tubes *L*, and the wire to which they are fastened, are movable, so as to come in contact with the small exterior iron tubes *K*, fig. 4, but are kept separate by the elastic spring above. At *E*, is the brass covering. On the transmission of an electric current through the helix, the tubes become magnetic. Such is the arrangement of their polarities, that they act by attraction and repulsion, overcome the elasticity of the spring, and bring the movable magnets down to the fixed ones—the current being broken, the spring separates them. The two flanches do not come in direct contact, though the movable one acts responsive to magnetic influence. Most of the magnetism exists at the flanches, and the order is such that the lower end of the inner tube has south polarity, the surrounding one above, the same, which repels it, while the top of the surrounding one below has north polarity, and attracts it; this movement is through a space of only one sixty-fourth part of an inch.

THE AIR VALVE AND PISTON.

On the same rod, above the movable magnets, is fixed a hollow cylindrical valve, having on its outer circumference the grooves 1, 2, 3, fig. 4. The plate represents a longitudinal half section of the valve, magnets, and helix. The valve slides in an air chamber *H*, which has two grooves, 1, 2, on its inner surface. Air is admitted through the orifice 1, by means of a pipe from the air chamber beneath the case into the middle groove of the valve. The grooves of the chamber open into the side passages *J* and *M*, which connect at right angles with a second chamber, in which a piston moves. The movement of the magnets changes the apposition of the grooves in the first chamber, by which air enters from the supply pipe, through one of the side passages, into the second chamber, at the same time that air on the other side of the piston in the second chamber escapes back into the grooves 1 and 2 of the valve, through the other side passage, and from them into the atmosphere. This causes the piston to slide backward and forward with every upward and downward motion of the valve.

This piston moves horizontally, and is connected with the lever *S*, fig. 5, of an escapement, the pallets of which alternately rest on the teeth of an escapement wheel of the printing machine *A*, fig. 5. This part of the apparatus is arranged on a circular iron plate, twelve or fourteen inches in diameter, supported by standards on the mahogany frame *H*, fig. 1. The escapement wheel revolves on a vertical shaft that passes

through the iron plate, and has fixed on it there a hollow pulley. This pulley contains within it a friction apparatus,

Fig. 5.

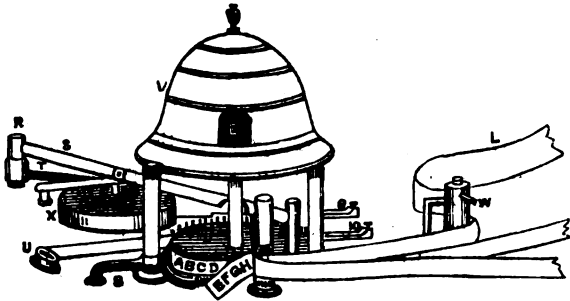

consisting of an ordinary spiral clock spring—the inner end of which is fastened to the shaft, and the outer pressing against the inner side of the case. Thus the spring is always about the same strength, and acts upon the escapement wheel, causing it to revolve uniformly when released by the escapement. The pulley revolves constantly, while the shaft and escapement wheel may be stopped. The escapement wheel has fourteen teeth, each one of which causes two motions of the escapement, which will make twenty-eight for a single revolution of the wheel, which is shown in fig. 7.

Fig. 6.



When in operation, the piston to which the escapement arm 8, fig. 5, is attached, is subjected, on one side or the other, to a pressure of condensed air; therefore the piston and escapement will only be moved by the escapement wheel when the air is removed from one side or the other of the piston. The position of the valve, fig. 4, attached to the magnet, regulates the pressure of air on either

Fig. 7.

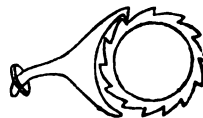

side of the piston, by opening one or the other of the side passages into the second chamber. By breaking and closing the circuit, therefore, the piston and escapement move backward and forward; thus a single revolution of the circuit wheel at one station opens and closes the circuit twenty-eight times, causing an equal number of movements of the magnets in another station; they carry the valve which alternately changes the air on either side of the piston. This permits the

escapement wheel to move the escapement and piston twenty-eight times, and allows one revolution of the escapement wheel for one of the circuit wheel at the transmitting station.

A steel type wheel, fig. 5, A, B, c, D, two inches in diameter, is fixed above and revolves on the same shaft with the escapement wheel; it has on its circumference twenty-eight equi-distant projections, on which are engraved in order the alphabet, a dot, and a dash. The fourteen notches of the escapement wheel cause twenty-eight vibrations of the escapement in a revolution, that correspond to the characters on the type wheel. Every vibration of the escapement, therefore, makes the type wheel advance one letter; these letters correspond to those on the keys of the composing machine. If any desired letter on the type wheel is placed in a certain position, and a corresponding key in the composing machine is depressed, by raising that key, and again depressing it, the circuit wheel at one station, and the escapement and type wheels at the other station, all make a single revolution, which brings that letter to its former position. Any other letter is brought to this position by pressing down its key in the composing machine, the circuit being broken and closed as many times as there are letters from the last one taken to the letter desired.

THE MANIPULATION.

To form the letters into words, it is necessary that the printing and composing machines should correspond, and for this purpose a small break and thumb screw, 9 and 10, fig. 5, can be made to stop the type wheel at any letter. In sending messages, they usually commence at the dash or space; if, by accident, the type wheel ceases to coincide with the distant composing machine, the printing becomes confused, the operator stops the type wheel, sets it at the dash, and the printing goes on as before.

Above the type wheel, on the same shaft, is the letter wheel E, fig. 5, on the circumference of which the letters are painted in the same order with those on the type wheel below. It is incased in a steel hood, having an aperture in it directly over where the letters are printed, so that when the type wheel stops to print a letter, the same letter is made stationary for a moment at the aperture, and is readily distinguished; hence messages can be read, thus making it a visual telegraph.

The type wheel has twenty-eight teeth arranged on the outer edge of its upper surface; near it, on the opposite side from where the printing is done, is the shaft τ , fig. 5,

revolving in an opposite direction. A steel cap *x*, fig. 5, two inches in diameter, is so attached to the top of this shaft that friction carries it along with it, but it can be moved in the opposite direction; it has a small steel arm, three fourths of an inch long, projecting from its side, and playing against the teeth on the type wheel; while the latter is revolving, its teeth strike this arm, and give the cap a contrary motion to its shaft. There is a pulley on this shaft, below the plate, connected by a band to *m*, fig. 1; its speed is less than that of the type wheel. When the type wheel comes to rest, the arm falls between the teeth, but it has not time to do so when they are in motion. On the opposite side of the cap to where the arm is attached are two raised edges, called detent pins, against which the detent arm *v*, fig. 5, alternately rests, as the position of the cap is altered by the small arm that plays on the teeth of the type wheel.

Between the type wheel and cap is a small lever and thumb-screw, 9, fig. 5, which acts as a break on the cap; its motion can be stopped by it, while the type wheel revolves; it is used merely to arrest the printing, though the message may be read from the letter wheel.

The detent arm revolves in a horizontal direction about the vertical shaft, which is also driven by a pulley beneath the steel plate; when the type wheel is at rest, the detent arm rests on one of the detent pins, but when it moves, the teeth on its upper surface give the arm and cap a reverse direction to its shaft, which alters the position of the detent points, so that the detent arm is liberated from this first pin, and falls upon the second, where it remains until the escapement and type wheels again come to rest; when this happens, the arm falls between two of the teeth, the cap resumes its first position, the detent is let loose, makes a revolution, and stops again on the first pin.

The shaft that carries the detent arm has an eccentric wheel, *r*, fig. 5, on it, above the arm; an eccentric wheel is one that has its axis of motion nearer one side than the other, and, while revolving, operates like a crank; from this eccentric is a connecting rod, *s*, which draws a toothed wheel against the type; this toothed wheel is supported in an elastic steel arm (shut out of view by the coloring band), on the opposite side of the type wheel from that of the eccentric, and revolves in a vertical direction; the band *e*, fig. 1, carrying the coloring matter to print with, passes between this and the type; the dots seen represent small teeth that catch the paper and draw it along, as the wheel revolves, between itself and a steel clasp,

operated by a spring that presses the paper against the teeth and keeps it smooth ; the clasp is perforated in such a manner that the type print through it ; there are two rows of teeth, one above, the other below the orifice.

The vertical wheel, fig. 5, is embraced in a ring by the connecting shaft s, and a rotary motion is imparted to it by a ratchet fixed to its lower surface, moving with it, and catching against two poles fastened to the steel plate below it ; the poles are pressed against the ratchet by springs, as shown in fig. 8 ; the wheel is octagonal, and every revolution of the eccentric turns it through one eighth of a revolution, and therefore presents a firm, flat surface to push the paper against the type, and advances sufficient for every letter, one being printed each time the detent arm revolves.

Fig. 8.

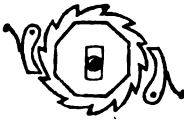

When the type wheel stops, the detent arm revolves, that carries with it the eccentric, which, through the connecting rod, draws the toothed wheel having the paper and coloring band before it against the type, and an impression is made on the paper ; a letter is printed if the circuit remains broken or closed longer than one tenth of a second ; three hundred letters, in the form of Roman capitals, can be accurately printed per minute ; the roll of paper L, fig. 5, is supported on a loose revolving wire framework ; on the same standard is a small pulley w, around which one end of the coloring band runs.

In transmitting a message, the machine is set in motion, a signal is given (which is simply the movement of the magnet), and then with the communication before him, the operator commences to play like a pianist on his key-board, touching, in rapid succession, those keys which are marked with the consecutive letters of the information to be transmitted ; on hearing the signal, the operator at the receiving station sets his machine in motion ; then setting his type at the dash, sends back signal that he is ready, and the communication is transmitted ; he can leave his machine, and it will print in his absence ; when the printing is finished, he tears off the strip which contains it, folds it in an envelope ready to send to any place desired.

The function of the electric current in this machine, together with the condensed air, is to preserve equal time in the printing and composing machine, that the letters in one may correspond with the other. The electrical pulsations determine the number of spaces or letters which the type wheel is per-

mitted to advance; they must be at least twenty-five per second to prevent the printing machine from acting; the intervals of time the electric currents are allowed to flow unbroken are equal, and the number of magnetic pulsations necessary to indicate a different succession of letters are exceedingly unequal; from A to B will require one twenty-eighth of a revolution of the type wheel, and one magnetic pulsation; from A to A will require an entire revolution of the type wheel and twenty-eight magnetic pulsations.

THE PATENTED CLAIM.

On the 28th December, 1852, Royal E. House obtained the following patent for various improvements on the original machine: "I claim, First. The employment of electro-magnetic force, in combination with the force of a current of air, or other fluid, so that the action of the former governs or controls the action of the latter, for the purpose described. Second. I claim the construction of the electro-magnet, as described; that is to say, a series of fixed magnets, in combination with a series of moveable magnets, arranged upon a central axis, which axis plays between or through the line of fixed magnets, so as to effect a vibratory movement of said axis by a force multiplied by the number of magnets of both kinds. Third. I claim the combination of the electro-magnet with the valve, for regulating and directing the force of a current of air, or other fluid, acting as a motive power upon the piston, or other analogous device for producing a vibratory motion, as described. Fourth. I claim the endless band, in combination with the cylinder, as an inking machine, for conveying and applying the coloring matter to the paper, at the moment of receiving the impression from the types, as described. Fifth. I claim the combination of the regulating bar with the type wheel, for the purpose of regulating the proper position said wheel should have, in connection with a given position of the key shaft, at the moment of printing any letters or characters."

HISTORY OF THE AMERICAN ELECTRO-MAGNETIC TELEGRAPH.

CHAPTER XXXI.

Invention of the Telegraph—The first Model of the Apparatus—Specimen of the Telegraph Writing—The Combined Circuits invented—Favorable Report of the Committee on Commerce in Congress—Construction of the Experimental Line—Invention of the Local Circuit—Improvements of the Apparatus—Administration of the Patents by Hon. F. O. J. Smith and Hon. Amos Kendall—Extensions of the Lines in America.

INVENTION OF THE TELEGRAPH.

THE patented American electro-magnetic telegraph was invented by Samuel Findley Breese Morse. It is not my purpose to discuss the questionable claims of others, in regard to their participation as auxiliaries in the perfection of the telegraph bearing the above name. It is my purpose to give the facts with but little comment. The reader can exercise his own judgment in the premises.

Mr. Morse was an historical painter, and much of his early life was spent in Europe in the perfection of his profession. In reference to the invention of the telegraph, Mr. Morse has deposed, in a case before the Supreme Court of the United States, as follows, viz. :

“Shortly after the commencement of my return voyage from Europe, in the autumn of 1832, before referred to, the then recent experiments and discoveries in relation to electro-magnetism, and the affinity of electricity to magnetism, or their probable identity, became the subject of conversation.

The special subject of conversation was the obtaining the electric spark from the magnet. In the course of the discussion, it occurred to me that by means of electricity, signs representing figures, letters, or words, might be *legibly written down* at any distance.

At this time the idea of telegraphing in any way by electricity was new to me, and so far as I could judge, to every one on board the ship. So far as my knowledge then extended, I was ignorant that any one had previously entertained even the idea of an electric telegraph. Subsequent investigation has, however, shown me that the first *idea* of telegraphing by electricity does not belong to me, and I therefore disclaim it; but in the modes proposed by me I *do* claim to have invented an entirely novel and useful mode and art of telegraphing.

All previously known modes of telegraphing were by evanescent signs. Had my invention rested merely in the idea, it would have been comparatively valueless; but at the same time I conceived a practical mode of carrying into effect my original idea. I claim then to have invented a new *art: the art of imprinting characters at a distance for telegraphing purposes*, and the mode and means of performing the same are set forth in my several letters patent. And I also claim the use of sounds for telegraphing as are set forth in my letters patent.

The idea thus conceived of an electric telegraph took full possession of my mind, and during the residue of the voyage, I occupied myself, in a great measure, by devising means of giving it practical effect. Before I landed in the United States, I had conceived and drawn out in my sketch book the form of an instrument for an electro-magnetic telegraph, and had arranged and noted down a system of signs, composed of a combination of dots and spaces, which were to represent figures or numerals, and these were to indicate words, to which they were to be prefixed in a telegraphic dictionary, where each word was to have its own number. I had also conceived and drawn out a mode of applying the electric or galvanic current, so as to make these signs by its chemical effects in the decomposition of salts; and so also to make sounds for telegraphing. Immediately after my landing in the United States, I communicated my invention to a number of my friends, and employed myself in preparations to prove its practicability and value by actual experiments.

To that end, before the commencement of the year 1833, being at the house of my brother, in New-York, I made a mould and cast a set of type representing dots and spaces, intended to be used for the purpose of closing and breaking the circuit in my contemplated experiments."

The type referred to in the above were precisely as those represented in fig. 1. The application of the type will be explained hereinafter. Their value is indicated by the top, thus, **A** is a dot and a dash, **B** a dash and three dots, &c.

Fig. 1.

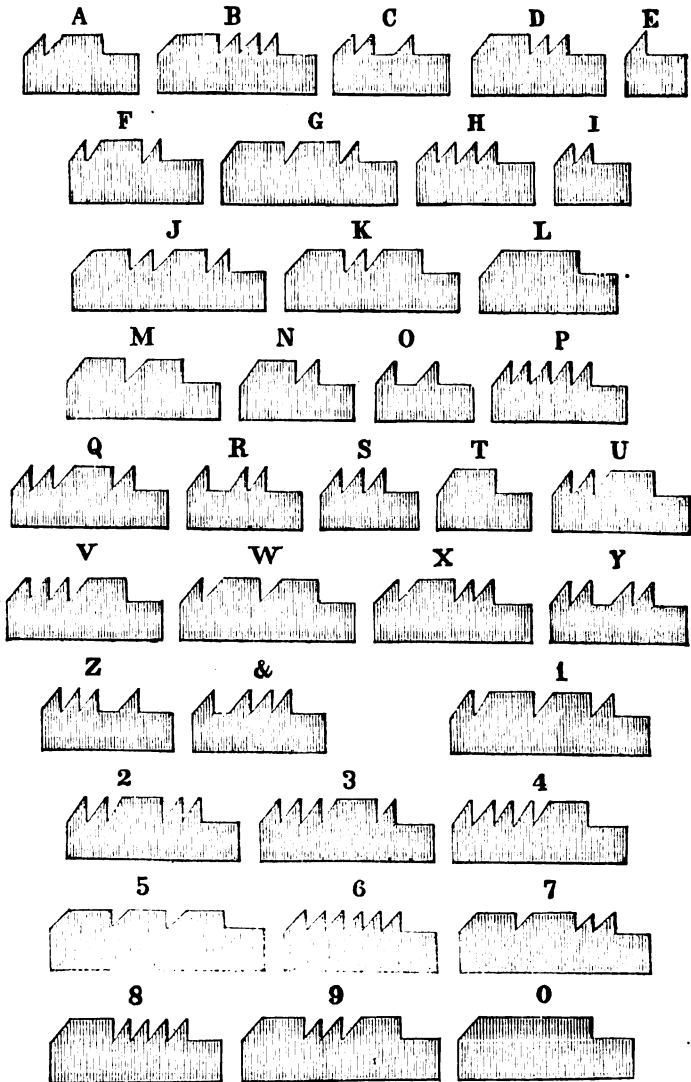

THE FIRST MODEL OF THE APPARATUS.

Morse's first instrument was made of an old picture frame, F A C F, fastened to a small table, as in fig. 2. The wheels of an old clock D were arranged to carry the paper forward, by the endless band connecting D with the cylinder axle C. The

weight *E* put in motion the clock-work. *A* is a cylinder on which rolls the ribbon paper, and *B* is an auxiliary drum in the movement of the paper. The paper unrolls from *C*, passes over the drum *B*, and winds around *A*. The movement of *A* is regulated by the weight attached to it. The pen lever is sus-

Fig. 2.

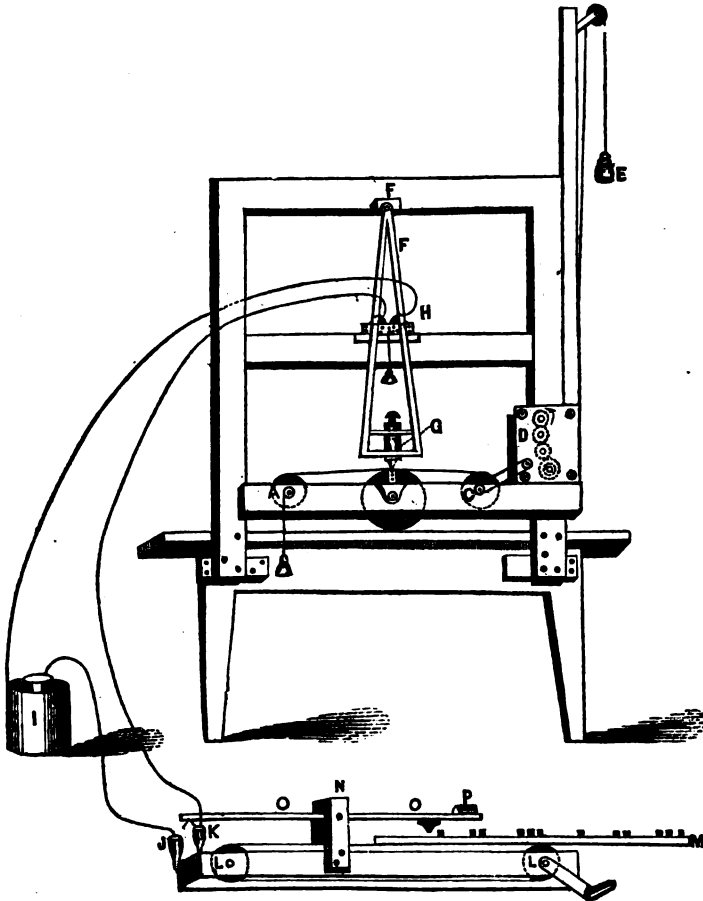

pended from *F*. It is composed of two diverging rods connected by two cross pieces at *G*, and at *H* is a steel bar to serve as an armature to the electro-magnet at *H*, the ends of which face the armature represented by the dotted bar. The wire runs from the battery cup *I* to the magnet coils, thence to *K*, and from *J*

back to the battery. When the battery is in electrical action, the magnet *h* attracts the armature, which draws the pen lever *f h g*. When the circuit is opened, a spring draws the pen lever from the magnet. The dotted lines from *g*, run to the pencil adjusted in the base of the lever. When the magnets attract the lever, the pencil makes a mark on the paper, and if the paper is in motion the mark will be oblique across, forming the half of the letter *v*. When the current is no longer in the magnet spools, the spring draws the lever back again, which forms the other half of the letter *v*. Mr. Morse formed his alphabet by a combination of the angles, as will be presently shown. I have in the above explained this primitive apparatus—the clock-work, magnet, paper rollers, pen lever, pencil, and the wire circuit. I will now describe the manner of opening and closing the voltaic circuit, which is consummated at *j k* by a simple mechanical arrangement. *l l* are the two cylinders or drums upon which is an endless band, moveable by a crank as seen to the right in the figure. *o o* is the circuit lever, *n* is its fulcrum and *p* a small weight to bear down that end of the lever so as to elevate the fork seen at the other end. *j k* are two small cups filled with mercury, into which is immersed at intervals the line wire. When the fork is made to descend into the mercury cup it closes the metallic circuit, and the electricity flows through the wires, the magnet spools, and then to the battery. *m* is a port-rule or a grooved piece of wood or metal. It is filled with the type represented in fig. 1. These type are moveable, but they fit solid in the port rule. When the crank is turned, the projection of the type presses under the subtending piece seen attached to the lever *o o*, which raises the lever at that end and depresses the other end, so that the forked ends enter the mercury in the cups *j k*. After the first type has passed the hanging projection *o*, the lever is elevated from the mercury cups. The crank then carries on the port-rule and another type passes, elevating the lever, closing the circuit at *j k*, which magnetizes the cores of the magnet *h*, attracting the armature of the pen lever *f h g*, and then the pencil makes its mark upon the paper.

In order that the port-rule may be the better understood, I will present the following as given by Mr. Alfred Vail:

“These type were set up in a cavity, made by putting two pieces of long rules of brass plate together, side by side, with a strip of half their width between them; so as to make the cavity sufficiently large to receive the type. This was denominated the *port rule*, and is represented in fig. 3 by *A*. Parts of the type are seen rising above the edge of the rule, and

below it are seen the cogs, by which with the wheel *v*, the pinion *L*, and the crank *o*, the port rule, with its type, were carried along at a uniform rate, in a groove of the frame, *k* *R*, under the short lever *c*, which has a tooth or cam at its extremity. *J* is a support, one on each side of the frame, for the axis of the lever *B* and *c*, at its axis *i*; *a* and *t* are two brass

Fig. 8.

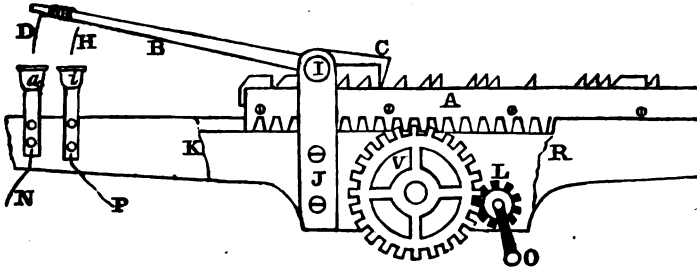

or copper mercury cups, fastened to the frame. Those cups have the negative and positive wires soldered to them, *n* and *p*. *D* and *n* are the ends of *one* copper wire, bent at right angles at that portion of it fastened to the lever *B*. The ends of the copper wire were amalgamated, and so adjusted that when the lever is raised at *c*, by the action of its cam passing over the teeth of the type, the lever *B* is depressed, and the wires *D* and *n* dip into the mercury cups, and thus complete the connection. This plan worked well, but was too inconvenient and unwieldy.

The second method was upon the same principle, with a more compact arrangement. The type being put into a hopper and carried one by one upon the periphery of a wheel, the teeth acting upon a lever in the same manner as in the figure preceding. The wheel being horizontal.

The third plan differed only in one respect, instead of the types moving in a circle they were made to move in a straight line. Fig. 4 represents that instrument. The type were all made with small holes through their sides, so as to correspond with the teeth of the wheel *A* driven by the clock-work and weight. *k* is the side of the frame containing the clock-work. *B* is the hopper containing the types, with their teeth outward. The hopper is inclined at an angle, so that the type may slide down as fast as one is carried through the cavity *a* and *b*. *c* is a brass block to keep the type upright, and sliding down with them. *E* and *F* are two small rollers, with springs (not shown) to sustain the type after the wheel *A* has carried them beyond its reach. *G* is a lever for the same purpose as *c* in fig. 3. *D*

its support, through which its axis passes. At *l* is the long lever *o* of the right-side figure, to the end of which is the bent wire in the mercury cups *h* and *s*, and to which are soldered the wires *p* and *n*. *t* is the spring to carry back the lever *o*. *f'* is one of the small rollers, and *c'* the short lever. At *r* may be seen a part of one of the type passing, the tooth having the short lever upon its point, thereby connecting the circuit at the mercury cups *h* and *s*, by the depression of the long lever *o*. The hopper *v* may be of considerable length, and at a less angle. when a communication is to be sent, it is set up in type and put in the hopper. The clock work is then put in motion, and the wheel *a* will carry them down one by one.

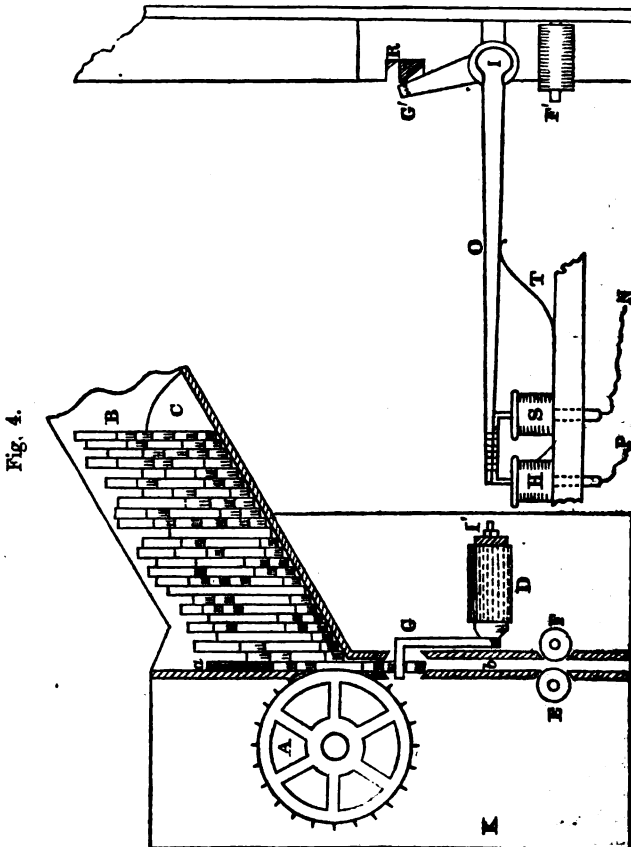
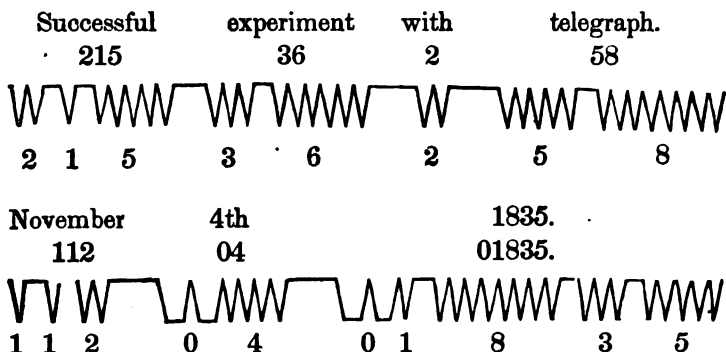

Fig. 4.

SPECIMEN OF THE TELEGRAPH WRITING.

The writing upon the paper with the pencil or fountain pen was rapid and intelligible and practically effective, though far less so than the more modern organizations of the alphabet. The following are specimens of the writing done by this plain and simple arrangement, at a public exhibition in the New-York City University, at a distance of one third of a mile.



The *words* in the diagram were the intelligence transmitted.

The *numbers* (in this instance arbitrary) are the number of the words in a telegraphic dictionary.

The *points* are the markings of the register, each point being marked every time the electric fluid passes.

The register marks but one kind of mark, to wit, (V). This can be varied two ways. By intervals, thus, (V VV VVV,) signifying one, two, three, &c., and by reversing, thus, (Δ). Examples of both these varieties are seen in the diagram.

The single numbers are separated by *short* and the whole numbers by *long intervals*.

To illustrate by the diagram: the word "successful" is first found in the dictionary, and its telegraphic number, 215, is set up in a species of type prepared for the purpose, and so of the other words. The type then operate upon the machinery, and serve to regulate the times and intervals of the passage of electricity. Each passage of the fluid causes a pencil at the extremity of the wire to mark the points as in the diagram.

To read the marks, count the points at the bottom of each line. It will be perceived that two points come first, separated by a *short* interval from the next point. Set 2 beneath it. Then comes one point, likewise separated by a short interval. Set one beneath it. Then comes five points. Set 5 beneath

them. But the interval in this case is a *long* interval; consequently the three numbers comprise the whole number, 215.

So proceed with the rest until the numbers are all set down. Then, by referring to the telegraphic dictionary, the words corresponding to the numbers are found, and the communication read. Thus it will be seen that, by means of the changes upon *ten* characters, all words can be transmitted, But there are *two points* reversed in the lower line. These are the *eleventh* character, placed before a number to signify that it is to be read as a *number*, and not as the representative of a word.

The telegraph apparatus above described was worked by Professor Morse, November, 1835, in the New-York City University, in the presence of Leonard D. Gale, D. Huntington, O. Loomis, Robert Rankin, and others. The facts are fully substantiated by the evidence given in various telegraph suits, and particularly in the case, Morse vs. O'Rielly, adjudicated upon by the Supreme Court of the United States. The apparatus above described is precisely in accordance with the idea held by Morse on the ship Sully in 1832. In substantiation of this fact, Captain Pell, the master of the ship, and others have testified, as will be found in the records of the Supreme Court of the United States, and the Federal Courts of Kentucky, Pennsylvania and Massachusetts.

Captain Pell deposed as follows:

"His plan of communicating intelligence at a distance was by imprinting signs at a distance. While on board the ship, he described his use of a galvanic trough, the circuit from which was to be broken and closed by means of a lever, acted upon by the tooth types, which were to be moved by a crank.

At the other extremity of the circuit was an artificial horse-shoe magnet, with a moveable armature, holding a pencil or pen, and carrying it by the movement communicated by the closing and breaking of the circuit, over a papered cylinder, on which it traced a succession of toothed marks. This was in the month of October, 1832. On that passage, Prof. Morse also showed me a sketch-book, in which were contained drawings of some of said telegraphic apparatus.

The said sketch-book was shown to me last spring, and I recognized it as the same sketch book shown to me in the possession of said Morse during said voyage of 1832. When it was so shown to me last spring, I wrote my name upon it and the date of my said signature.

I distinctly recollect that the said sketch-book, at the time that I saw it on board the packet-ship Sully, had in it certain drawings which I recognized when I wrote my name upon

said leaf, as before stated; and also on another page, other drawings of the part of the apparatus and machines described by Professor Morse for his telegraph, which I also recollected having seen in said book during the voyage aforesaid, and I recognized them when so shown to me last spring, and then wrote my name upon the page containing them.

When said Morse showed me an apparatus and machine in operation at the University, in the city of New-York, I recognized the instrument the moment I saw it as being constructed upon the same general principles of the telegraphic instrument described by Professor Morse on board the ship Sully, on his passage from Havre, in 1832."

Such was the telegraphic apparatus devised by Morse on the ship Sully in 1832, and exhibited to his friends in 1835. In the year 1836 he had the same telegraph on public exhibition in the city of New-York.

THE COMBINED CIRCUITS INVENTED.

The combination above described satisfied every one of its practicability on short voltaic circuits, and it became a question how far the current could be transmitted over a wire to produce magnetism in a piece of soft iron.

The following extracts are taken from the deposition of Prof. Morse, filed in the Supreme Court of the United States:

"Early in 1836, I procured forty feet of wire, and putting it in the circuit I found that my battery of one cup was not sufficient to work my instrument. This result suggested to me the probability that the magnetism to be obtained from the electric current would diminish in proportion as the circuit was lengthened, so as to be insufficient for any practical purposes at great distances; and to remove that probable obstacle to my success, I conceived the idea of combining two or more circuits together in the manner described in my first patent, each with an independent battery, making use of the magnetism of the current on the first to close and break the second; the second, the third; and so on."

Fig. 5.

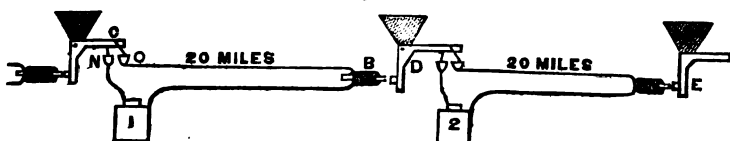

This arrangement is represented by fig. 5, in which three electro magnets, B, are shown. Numerals 1 and 2 are two

stations twenty miles apart. At station 1 are two mercury cups, *n* o, into which the forked wire at *c* descends and closes the circuit. The battery current of station 1 follows the wire to *n*, through the forked wire *c* to *o*, thence to the magnet *b*, and after passing around the soft iron, it returns to the battery at 1. When the current passes around *b*, the magnet attracts the armature of the right angle lever *d*, which causes the forked wire to descend into the mercury cups of the station 2, which puts in action the battery of 2. The second twenty-mile circuit is then charged and the magnet at *e* attracts the armature, and thus another circuit is put in motion. The three equilateral triangular pieces attached to the right-angled levers are weights to draw from the mercury cups the forked wires when the magnets cease to attract the subtending part of the armature lever. The levers *d* are fixed to pivots as fulcrums at their angles. This arrangement was termed the "combined circuits," and was publicly exhibited at the University in March, 1837. The plan represented could telegraph only in one direction. To communicate back another combination of circuits would have to be organized upon the reverse order. At that time there was no evidence on record demonstrating that a circuit as great as twenty miles could be operated. The apparatus, therefore, was based upon theory, but that problem has long since been solved by the practical extension of the circuit several hundred miles for telegraphic purposes.

Prof. Morse further deposed that, "In 1836 and the early part of 1837, I directed my experiments mainly to modifications of the marking apparatus, contrivances for using fountain pens, marking with a hard point through pentagraphic or blackened paper, varying in the modes of using and moving the paper; at one time on a revolving disk spirally from the centre, at another on a cylinder, by which means a large ordinary sheet of paper might be so written upon that it could be read as a commonplace book, and bound for reference in volumes, and devising modes of marking upon chemically prepared paper. As my means and the duties of my profession would admit, the spring and autumn of 1837 were employed in improving the instrument, varying the mode of writing, experimenting with plumbago and various kinds of ink or coloring matter, substituting a pen for a pencil, and devising a mode of writing on a whole sheet of paper instead of upon a strip or ribbon; and in the latter part of August or the beginning of September of that year, the instrument was shown in the cabinet of the University to numerous visitors, operating through a circuit of one thousand seven hundred feet of wire running back and forth in that room."

In the perfection of the apparatus and the scientific appliances, Prof. Morse had the invaluable aid of Prof. Leonard D. Gale and Messrs. George and Alfred Vail. These gentlemen became interested in the patents subsequently obtained.

In September, 1837, the government of the United States issued a circular, in conformity to a resolution that passed Congress in February, 1837, seeking propositions upon the subject of telegraphs. A correspondence followed with Prof. Morse, but nothing was effected. In October, 1837, Morse filed his caveat in the United States Patent Office. Later in the year 1837, a model instrument was completed and operated before the Franklin Institute at Philadelphia on a circuit of ten miles. Thence the apparatus was removed to Washington, where it was exhibited in successful operation to a multitude of persons, among whom were the President, members of the Cabinet, Senators and Representatives in Congress. It was placed in the room of the Committee on Commerce in the Capitol.

FAVORABLE REPORT OF THE COMMITTEE ON COMMERCE IN CONGRESS.

At that session Prof. Morse had an application pending before Congress, for an appropriation to aid in the construction of an experimental line between Washington and Baltimore. The subject had been referred to the Committee on Commerce, the chairman of which was the distinguished representative, Mr. Francis O. J. Smith. That gentleman was at once struck with the practicability of the invention, and he exerted his great powers in its behalf. The invention was novel, and it was difficult to get members of Congress to believe in the possibility of success. The Honorable Mr. Smith, however, never ceased his efforts in behalf of Morse, fully believing his telegraph to be, as he declared, "the most wondrous birth of this wonder-teeming age." He succeeded in getting the entire committee to sign the following report:

Mr. Smith, from the Committee on Commerce, made the following report, April 6th, 1838:

"The Committee on Commerce, to whom the subject was referred, have had the same under consideration and report: On the 3d of February, 1837, the House of Representatives passed a resolution requesting the Secretary of the Treasury to report to the House, at its present session, upon the propriety of establishing a system of telegraphs for the United States.

In pursuance of this request, the Secretary of the Treasury, at an early day after the passage of said resolution, addressed a circular of inquiry to numerous scientific and practical indi-

viduals in different parts of the Union; and on the 6th of December last, reported the result of this proceeding to the House.

This report of the Secretary embodies many useful suggestions on the necessity and practicability of a system of telegraphic despatches, both for public and individual purposes; and the committee cannot doubt that the American public is fully prepared, and even desirous that every requisite effort be made on the part of Congress to consummate an object of so deep interest to the purposes of government in peace and in war, and to the enterprise of the age.

Amid the suggestions thus elicited from various sources, and embodied in the before mentioned report of the Secretary of the Treasury, a plan for an electro-magnetic telegraph is communicated by Professor Morse, of the University of the City of New York, pre-eminently interesting, and even wonderful.

This invention consists in the application, by mechanism, of galvanic electricity to telegraphic purposes, and is claimed by Professor Morse and his associates as original with them; and being so, in fact, as the committee believe, letters patent have been secured, under the authority of the United States, for the invention. It has, moreover, been subjected to the test of experiment, upon a scale of ten miles' distance, by a select committee of the Franklin Institute of the city of Philadelphia, and reported upon by that eminently high tribunal in the most favorable and confident terms.

In additional confirmation of the merits of his proposed system of telegraphs, Professor Morse has exhibited it in operation (by a coil of metallic wire measuring about ten miles in length, rendering the action equal to a telegraph of half that distance) to the Committee on Commerce of the House of Representatives, to the President of the United States, and the several heads of departments, to members of Congress generally, who have taken interest in the examination, and to a vast number of scientific and practical individuals from various parts of the Union; and all concur, it is believed, and without a dissenting doubt, in admiration of the ingenious and scientific character of the invention, and in the opinion that it is successfully adapted to the purposes of telegraphic dispatches, and in a conviction of its great and incalculable practical importance and usefulness to the country, and ultimately to the whole world.

But it would be presumptuous in any one (and the inventor himself is most sensible of this) to attempt, at this stage of the invention, to calculate in anticipation, or to hold out

promises of what its whole extent of capacity for usefulness may be, in either a political, commercial or social point of view, if the electrical power upon which it depends for successful action shall prove to be efficient, as is now supposed it will, to carry intelligence through any of the distances of fifty, one hundred, five hundred or more miles now contemplated. No such attempt, therefore, will be indulged in this report. It is obvious, however, that the influence of this invention over the political, commercial, and social relations of the people of this widely-extended country, looking to nothing beyond, will, in the event of success, of itself amount to a revolution unsurpassed in moral grandeur by any discovery that has been made in the arts and sciences, from the most distant period to which authentic history extends to the present day. With the means of almost instantaneous communication of intelligence between the most distant points of the country, and simultaneously between any given number of intermediate points, which this invention contemplates, space will be, to all practical purposes of information, completely annihilated between the States of the Union, as also between the individual citizens thereof. The citizen will be invested with, and reduce to daily and familiar use, an approach to the HIGH ATTRIBUTE OF UBIQUITY, in a degree that the human mind, until recently, had hardly dared to contemplate seriously as belonging to human agency, from an instinctive feeling of religious reverence and reserve on a power of such awful grandeur.

Referring to the annexed report of the Franklin Institute, already adverted to, and also to the letters of Professor Morse, marked 2, 8, and 9, for other details of the superiority of this system of telegraphs over all other methods heretofore reduced to practice by any individual or government, the committee agree unanimously, that it is worthy to engross the attention and means of the Federal Government, to the full extent that may be necessary to put the invention to the most decisive test that can be desirable. The power of the invention, if successful, is so extensive for good or for evil, that the Government alone should possess the right to control and regulate it. The mode of proceeding to test it, as suggested, as also the relations which the inventor and his associates are willing to recognize with the Government on the subject of the future ownership, use, and control of the invention, are succinctly set forth in the annexed letters of Professor Morse, marked 8 and 9.

The probable outlay of an experiment upon a scale equal to fifty miles of telegraph, and equal to a circuit of double that distance, is estimated at \$30,000. Two thirds of this expen-

diture will be for material, which, whether the experiment shall succeed or fail, will remain uninjured, and of very little diminished value below the price that will be paid for it.

The estimates of Professor Morse, as will be seen by his letter, marked 9, amount to \$26,000; but, to meet any contingency not now anticipated, and to guard against any want of requisite funds in an enterprise of such moment to the Government, to the people, and to the scientific world, the committee recommend an appropriation of \$30,000, to be expended under the direction of the Secretary of the Treasury; and to this end submit herewith a bill.

It is believed by the committee that the subject is one of such universal interest and importance, that an early action upon it will be deemed desirable by Congress, to enable the inventor to complete his trial of the invention upon the extended scale contemplated, in season to furnish Congress with a full report of the result during its present session, if that shall be practicable.

All which is respectfully submitted.

FRANCIS O. J. SMITH,	JAS. M. MASON,
S. C. PHILLIPS,	JOHN T. H. WORTHINGTON,
SAMUEL CUSHMAN,	WM. H. HUNTER,
JOHN I. DE GRAFF,	GEORGE W. TOLAND,
EDWARD CURTIS,	

Committee on Commerce, U. S. H. R."

Nothing further was effected at that session of Congress, and but little hope was entertained that Congress would ever grant the desired appropriation. Mr. F. O. J. Smith was so well convinced of the practicability of the system of telegraph, that he abandoned his seat in Congress, and purchased one quarter interest in the invention for Europe and America, under date of March, 1838. In May, 1838, Professor Morse and Mr. Smith visited Europe to obtain patents and to make sales of the invention. In England a patent was refused, because a brief description of the invention had been published. In France a patent was granted, but by order of the government he was forbidden to put it in operation, and at the end of two years the patent expired. The various efforts in Europe proved of no avail.

In June, 1840, Professor Morse obtained his patent in the United States, based on the specification filed by him in April, 1838. In December, 1842, he petitioned Congress again for aid to test the practicability of his invention, and on the 30th of December the Committee on Commerce reported a bill in

favor of appropriating \$30,000 for that purpose. The bill passed the House of Representatives, and in the last hour of the last night of the last session of that Congress, March 3d, 1843, the bill passed the Senate, was signed by the President, and became a law.

CONSTRUCTION OF THE EXPERIMENTAL LINE.

The experimental line between Washington and Baltimore was placed under course of construction in 1843. It was attempted to make it subterranean. Two copper wires, covered with cotton and gum-lac, were drawn through a leaden tube. From Baltimore to the Relay House, nine miles, were thus laid in the earth. On testing it an earth circuit was found; not even a mile of it could be worked. The plan proved a failure. Professor Morse then, after consultation with his friends, determined to put the wires on poles. The same copper wire that had been drawn through the leaden tubes for much of the distance between Baltimore and Washington were taken from the tubing and stretched on poles.

In May, 1844, the line was completed between those cities, and on the 27th day of May the first dispatch was transmitted over the line from Washington to Baltimore. It fell to the lot of Miss Annie Ellsworth to send that dispatch, which was, "WHAT HATH GOD WROUGHT?" As manipulating assistants, Professor Morse had Mr. Alfred Vail and Mr. L. F. Zantzinger, the former is no more, and the latter still remains attached to the profession of practical telegraphing, and is the oldest now in the service.

The apparatuses used were large and weighty. The electro-magnet weighed one hundred and eighty-five pounds, and its bulky construction made it necessary for two men to handle it whenever it had to be moved. It was placed in a large box. Fig. 4 represents, in part, the receiving magnet as then used.

Fig. 4.



B B were the coils of wire, three and one half inches long and eighteen inches in diameter. The soft iron bars are A A. The copper wire surrounding the spools was No. 16 copper wire covered with cotton thread. It was then supposed, by Professor Morse, as indispensably necessary that the wire surrounding the magnets should be the same size as that stretched

upon the poles of the line. This monster form of magnet was continued for a short time, and replaced by another less in size, devised by Professor Charles G. Page. These latter remained in the service until substituted by some of the size now in use, which had been purchased by Professor Morse in France in the year 1845.

INVENTION OF THE LOCAL CIRCUIT.

In regard to the invention of the local circuit, Professor Morse deposed, viz. :

"I further state, that the combination of machinery in constructing my telegraph as put in operation in 1844, was different from that originally contemplated and described in my first patent in the following respects, viz. : The combined circuits of my first patent, were the combination of two or more circuits as links in a main line for the purpose of renewing the power and propelling forward, indefinitely, the electric current, in such volume as to render the power more available at the distant point, and to charge an electro-magnet with sufficient magnetic force to work a register or move the lever of a relay magnet, suggested by the probability indicated by my own experiments and the experiments of scientific men, that sufficient magnetic power could not be obtained from the electric current through a very long circuit to make a mark of any sort.

This difficulty the undersigned proposed to obviate by means of two or more circuits, each with a battery, coupled together and broken and closed by means of the same principles as the receiving magnet now used ; these links of one main line are to be made so short as to secure the necessary magnetic power.

The register was to be placed, not in a short circuit, as now arranged, but on a link in the main line. But this arrangement was liable to the practical inconvenience that it would always require two lines of wire, both always in order ; because the receiving magnet would work only in one direction.

While preparing to build the line from Washington to Baltimore, I ascertained, by experiment upon one hundred and sixty miles of insulated wire, and, sometime previously, upon thirty-three miles of wire, that magnetic power sufficient to move a metallic lever could be obtained from the electric current of a circuit of indefinite length, and that there was no necessity for combining two or more circuits together *for the purpose of renewing the power at short intervals on the main line.*

I then devised the present combination, which enables me to work the same wire both ways, dispensing with one of

the two wires originally supposed to be necessary under all circumstances. This combination consists of one main circuit, connected by the receiving magnet with as many short office-circuits as may be desired, upon which respectively are the requisite registers, and not upon the lines of the main line, as originally contemplated. Any of these office-circuits may be separated from the main line without affecting its efficiency; whereas the breaking of a link in the chain of circuits originally contemplated would interrupt all communication. In that combination the battery at each station was to perform the double purpose of working the register and breaking and closing the next circuit in the main line.

In the present combination, the purpose of the battery on the main line is to close and break the short independent office-circuit, which works the register. This new combination of parts was a most valuable improvement upon my first plan. A part of this improvement was used on the experimental line between Washington and Baltimore, for the first time, in May, 1844, and the whole of the improvements in the year 1846.

The combination of circuits mentioned in my French patent of October, 1838, is the same as that mentioned in my American patent of 1840, and not that described in my American patent of April 11th, 1846."

IMPROVEMENT OF THE APPARATUS.

The original mode of manipulating the apparatus for marking on paper, and the mode of making those marks, were changed before the patent of 1840. The crank and port-rule were patented, but a better equivalent was found in the lever key, as in the chapter descriptive of the Morse telegraph apparatus.

The pen lever was changed in its position, so that instead of making the v lines it made a dot or a dash. The mechanism of fig. 2 can be easily changed to make the dot and dash. It is only necessary to place the paper cylinders in a perpendicular position. The face of the paper will be in front of the reader. Change the pencil *c* to a horizontal position in the lever, so that the marking end will rest opposite to the surface of the ribbon paper. When the paper and the pencil are thus arranged the following will be the result. The paper is moved forward, the current causes the magnets to attract the lever, which brings the pencil point against the paper. The mark on the paper will be in length proportional to the time the lever is held by the magnet. If but a moment, a dot will be made; if longer, a dash. The v marks will, therefore, not be made, but in their stead, dots and dashes.

The first key was very plain and simple, as well as the other parts of the mechanism. Attached to the marking lever were fountain pens, gotten up by Mr. Alfred Vail. To each lever were fastened four pens, which dropped the ink upon the paper. After that improvement the metallic points were adopted. There were at first four pens, then three, then two, and finally one pen. The marking process was soon abandoned, and the indenting of the paper substituted. The object of having more than one pen was to secure the mark, if one failed to drop the ink or to indent the paper the others might not.

Many were the improvements made to the different parts of the mechanism. At that time, and since then, the ingenious telegraphers throughout the world have, from time to time, devised important modifications to the different parts, having in view the perfection of the mechanism. The most remarkable change has been made in the receiving magnet; at first it weighed one hundred and eighty-five pounds, and now it is practically used in weight less than a pound, and so constructed that it can be carried, connected with the key, in the pocket.

ADMINISTRATION OF THE PATENTS.

After the completion of the experimental line between Washington and Baltimore, the commercial advantages resulting from the extension of the telegraph over the country began to be appreciated. It soon became a commercial affair, requiring peculiar powers to manage it, and to this end the Honorable Amos Kendall was made the attorney for Messrs. Morse, Vails, and Gale, the proprietors of three fourths of the patent. Mr. Kendall had been Postmaster-General of the United States, and had managed its affairs with distinguished ability. It was such ability that Professor Morse brought to the management of his telegraph. Mr. Kendall entered into the affairs with great zeal, and in a short time the lines were being spread throughout the country. Mr. Kendall devoted his special attention to the South and Southwest, and Mr. Smith to the East and Northwest. These gentlemen thus combining their remarkable powers, extended the telegraph to all the principal towns and cities in the United States, amounting in the aggregate to some forty-five or fifty thousand miles of telegraph wires, all of which are operated upon commercial principles, beneficial to the affairs of the people and of the government of the nation.

I have now followed the progress of the Morse telegraph from its beginning until its full development by its extension over the widespread territories of the American Union.

From the foregoing it will be seen that Morse devised a system of telegraphing in 1832, and that he made some type for the model; that in 1835-'36, he exhibited it in operation to his friends in New-York; in 1837 he devised his system of combined circuits; in 1844 he applied the local circuit, without the combination of circuits on the main line, and on the 27th day of May, 1844, he worked successfully the line, forty miles long, from Baltimore to Washington; and that the first dispatch, benign in its source and conception, was,

“WHAT HATH GOD WROUGHT?”

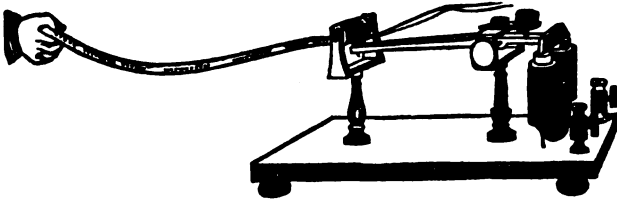

THE MORSE TELEGRAPH APPARATUSES.

CHAPTER XXXII.

The Early Telegraph Instruments—Modern Lever Key—The Early Circuit Changer—Modern Circuit Closers—Nottebohn's Circuit Changer—Binding Connections—The Electro-Magnet of 1844—The Modern Relay Magnet—The Receiving Register—The Sounder.

THE EARLY TELEGRAPH INSTRUMENTS.

THE present chapter will be devoted to the description of the various parts of the Morse telegraph apparatuses, which have been and are in use for practical telegraphy.

The original patented instruments were soon superseded by mechanism more convenient for the peculiar service. On the experimental line constructed between Baltimore and Washington, the register was similar to that represented by fig. 1, having three pen points to indent the letter into the paper. The perspective view shows the whole instrument. The electro-magnet $h h$, the pen-lever L , and the armature F , will be better seen on reference to fig. 3, which represents a part of fig. 1. Numerals 1, 1, 1, of fig. 1, represents the reel of paper, with its axle at y , fitted into the brass standard v at 12; 2, 2, is the paper coming from the reel, passing between the rollers $e f$, as seen in fig. 2; 11 is a metallic trough; and 3 is the paper after it has been marked by the pen points r ; 4 is the weight that puts in motion the clockwork revolving wheel b , fig. 2, to which is fastened the pulley r' , with an endless band 10, which puts in motion the wheel q . Fig. 3 represents the rear part of fig. 1, showing the electro-magnet. The letters $a b$, in figs. 1 and 3, are the line wires, one running to the battery, and the other to the telegraph poles. When the current passes through the coils, $h h$, the armature F is attracted, and the lever w attached is elevated in the direction of the arrow, causing the small steel points r to puncture the paper passing

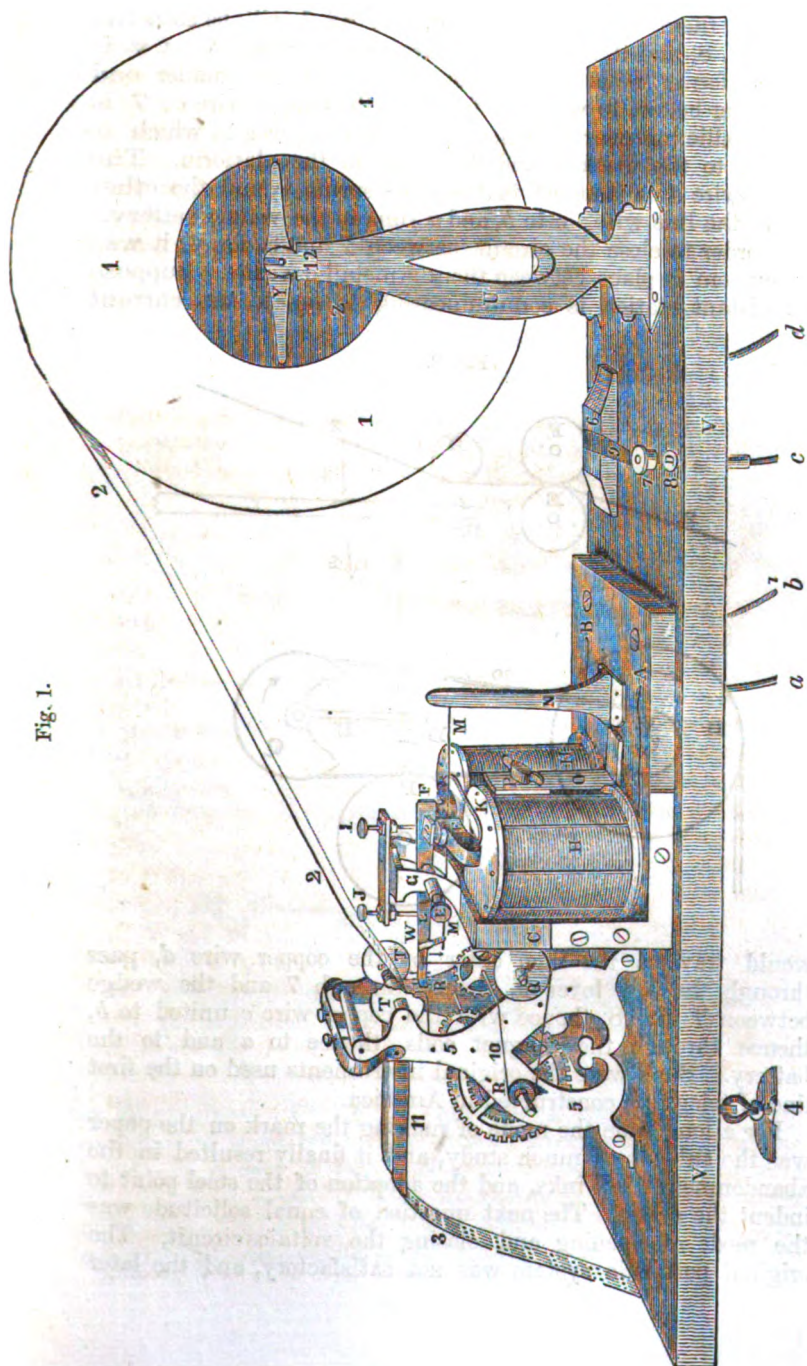
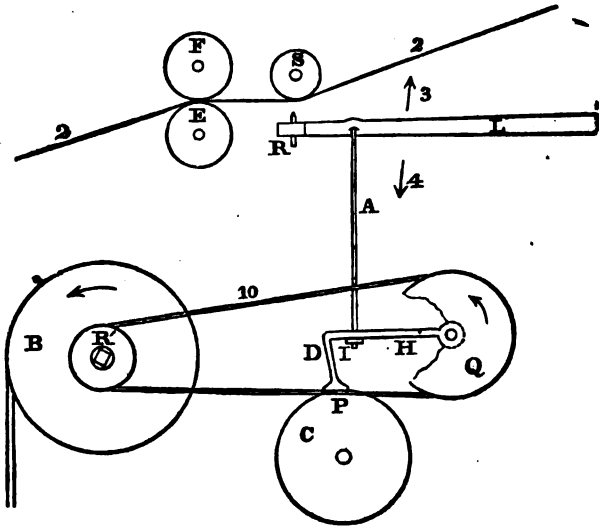

Fig. 1.

between them and the roller *r r*. In fig. 1 will be seen the key 6, 7, 8, and 9, shown on a large scale by fig. 4. *v v* is the platform; 8 is a metallic anvil, with its smaller end appearing below, to which is fastened the copper wire *c*; 7 is the metallic hammer attached to the brass spring 9, which is secured to the block 6, and the whole to the platform. The copper wire *d* is fastened to the brass spring 9, and the other end to the line wire; *c* to *b*, and *a* runs to the voltaic battery.

In order to close the circuit between 7 and 8, fig. 4, it was the custom to place between them a metallic wedge. Suppose the distant station is communicating to fig. 1, the current

Fig. 2.



would traverse the line, enter by the copper wire *d*, pass through the key lever 9, thence through 7 and the wedge between 7 and 8, thence with the copper wire *c* united to *b*, thence through the magnet coils, thence to *a* and to the battery. Such were the original instruments used on the first line of telegraph constructed in America.

For a long time the mode of making the mark on the paper was the subject of much study, and it finally resulted in the abandonment of all inks, and the adoption of the steel point to indent the paper. The next question of equal solicitude was the mode of opening and closing the voltaic circuit. The original port rule system was not satisfactory, and the later

mode—the use of the key and wedge, represented in figs. 1 and 4—was objectionable, as it did not firmly close the circuit.

Fig. 3.

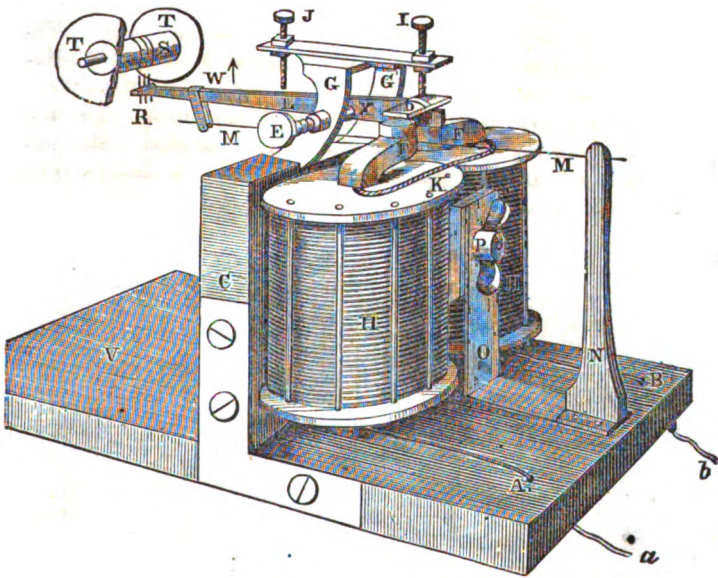

It was proposed to use a key-board, represented by figs. 5, 6, and 7.

Figs. 5 and 6 exhibit views of the keyed correspondent, with its clockwork. A' represents a top view of it, and B' is a side

Fig. 4.

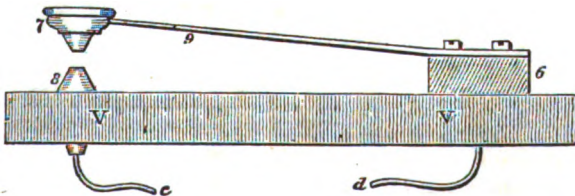

or front view. 1111, of both views, represent the long cylinders of sheet brass, covered with wood or some insulating substance, except at the black lines, which represent the form of the letters, made of brass, appearing at the surface of the cylinder and extending down and soldered to the interior brass cylinder. A cross section of the cylinder is seen at *v'*, of which

the blank ring is the brass cylinder, and the blank openings to the outer circle the metallic forms of the letter J, and the shaded portion of the circle represents the insulating substance, covering the whole surface of the cylinder, except where the letter-forms project from the interior. Every letter and parts of each letter are in metallic connection with the brass cylinder. At each end of the cylinder is a brass head, with its metallic journal, and the journal or arbor turns upon its centre in a brass standard, 17, secured to the vertical frame. To this standard is soldered the copper wire n, connected with the negative pole of the battery. There are together thirty-seven letters and numerals upon the cylinder. and made to correspond

Fig. 5.

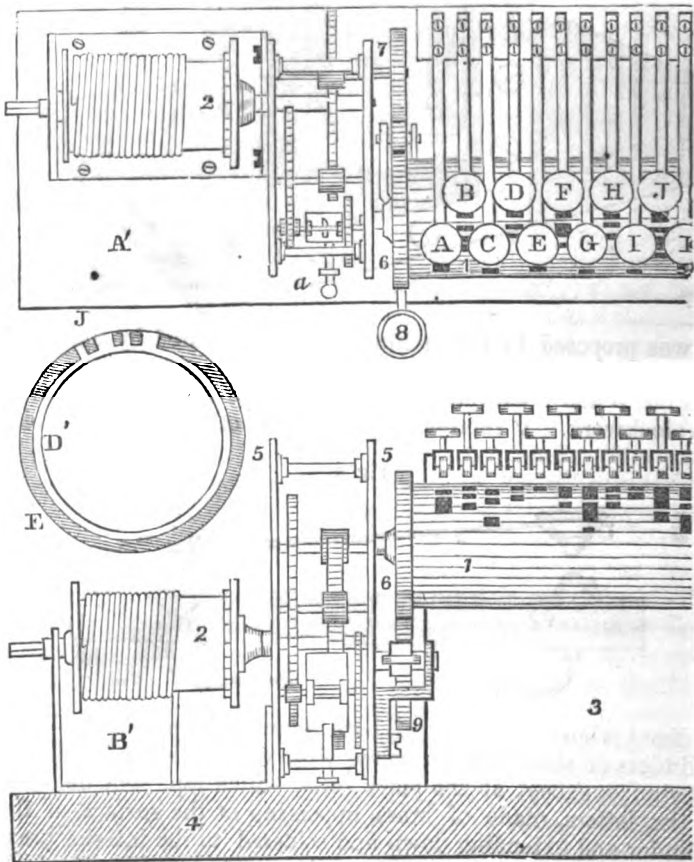

Fig. 6.

to the letters of the telegraphic alphabet. To each of these there is a separate key, directly over the letter cylinder. Each key has its button, with its letter A, B, C, D, &c., marked upon it, and beneath the button in a frame of brass is a little friction roller. The key is a slip of thin brass, so as to give it the elasticity of a spring, and is secured at the thicker end by two screws to a brass plate, extending the whole length of the cylinder, so as to embrace the whole number of keys. This plate is also fastened to the vertical mahogany frame. At the right-hand end of the brass plate is soldered a copper wire, leading to the positive pole of the battery, after having made its required circuit through the coils of the magnet, &c. It is

Fig. 5.

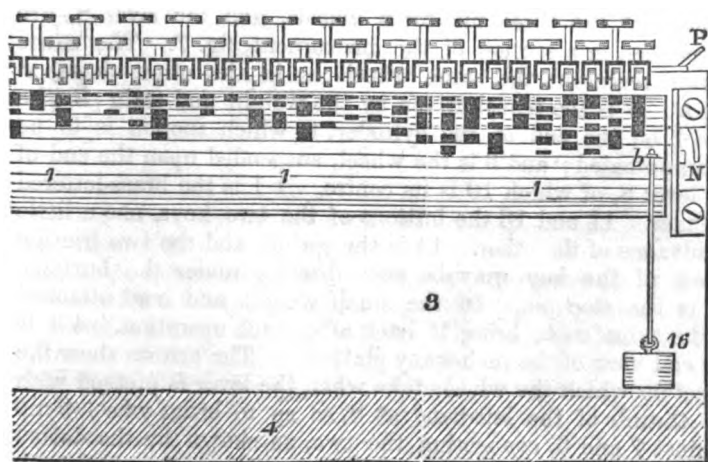
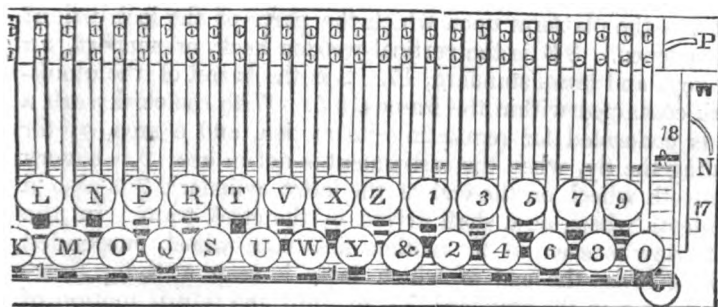

Fig. 6.

clear that if any one of the keys is pressed down upon any portion of a metallic letter, that the circuit is completed: the voltaic fluid will pass to the brass plate to which, *r*, wire is soldered; thence along the plate to the spring or key; then to the small friction roller beneath the button; then to that portion of any letter with which it is in contact; then to the interior brass cylinder, to the arbor; then to the brass standard, and along the negative wire, soldered to it, to the battery. I have now to explain in what manner the cylinder is made to revolve at the instant any particular key is pressed, so that the metallic form of the letter may pass at a uniform rate under the roller of the key; breaking and connecting the circuit so as to write at the register, with mechanical accuracy, the letter intended.

4 4 is the platform upon which the parts of the instrument are fastened. 3 3 is the vertical wooden back, or support, for the keys and brass standard, 17. 2 is the barrel of the clockwork contained within the frames, 5 5. With the clockwork a fly is connected for regulating its motion, and a stop, *a*, for holding the fly, when the instrument is not in use; 6 is a very fine-tooth wheel, on the end of the letter cylinder; 7 is also a fine-tooth wheel, on a shaft driven by the clock train. In the front view is seen, at 9, another fine-tooth wheel, suspended upon a lever, the end of which lever is seen at 8, fig. 5, *a'*. 18 is a stop in the standard, 17, to limit the return motion of the cylinder, which also has a pin at 18, at right angles with the former. 16 is a small weight, attached to a cord, and at its other end is fastened to the cylinder at *b*. The relative position of the three fine-tooth wheels, and the lever 8, are better seen in a section of the instrument, fig. 7. The same figures represent the same wheels as in the other views, *a'* and *b'*. 7 is the wheel driven by the weight and train; 6 the wheel, on the end of the cylinder, to which motion is to be communicated; and 9 is the wheel, suspended upon the end of the lever 8, of which 10 is its centre. 1 1 is the brass-lettered cylinder. 11 and 13 the buttons of the two keys, one a little in advance of the other. 14 is the spring, and the two friction rollers of the key may be seen directly under the buttons. 15 is the stop pin. 16 the small weight and cord attached to the cylinder, to bring it back after each operation. 4 4 is the end view of the mahogany platform. The arrows show the direction which the wheels take when the lever is pressed with the thumb of the left-hand at 8, so as to bring wheel 9 up against 7 and 6, connecting the two, as shown by the dotted lines. Wheel 7, communicating its motion to 9, and 9 to 6,

which causes the metallic letters to pass under the rollers in the direction of the arrow. Now, in order to use the instrument, let it be supposed a letter is to be sent. The stop *a*, fig. 5, Δ' , is removed from the fly, and the clockwork is set in motion by the large weight. Then the thumb of the left hand presses upon the *lever* 8, at the same time *key* *r* is pressed down by the finger of the right hand, so that the small roller comes in contact with the cylinder. At the instant the roller touches the cylinder, the letter begins to move under the small roller, making and creaking the circuit with mechanical accuracy. When the letter has passed under the small roller, the

Fig. 7.

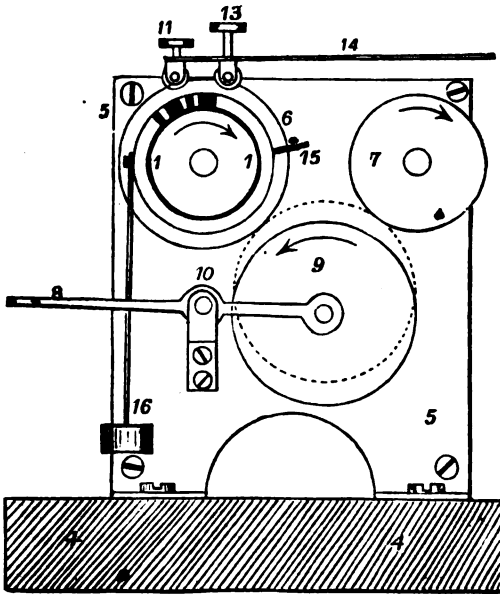

thumb is taken off the lever 8, and the finger from the key *r*. The cylinder is then detached from its gear wheel 9, and the weight, 16, instantly carries it back to its former position, in readiness for the next letter. Then the *lever* 8, and the *key* *e* are pressed down at the same instant for the next letter, and it is carried under the small roller in the same manner as the first, which, when finished, the wheel 9 is suffered to fall, and the cylinder returns to its natural position again. The same manipulation is repeated for the remaining letters of the word.

In fig. 8 is represented the flat correspondent. It somewhat

resembles the keyed correspondent, but without keys or clock-work. A represents the arrangement of the letters, presenting a flat surface. Those portions in the figure marked by black lines and dots represent the letters which are made of brass. That portion which is blank represents ivory or some hard insulating substance surrounding the metal of the letters. As in the keyed correspondent, each letter and parts of each letter extend below the ivory, and are soldered to a brass plate, the size of the whole figure A. A sectional view of this is seen at 1 1, which is ivory, and 2 2, the brass plate below. The whole is fastened to a table, B. 5' and 5' is a brass plate, called the guide plate, with long openings, represented by the blanks, so

Fig. 12.

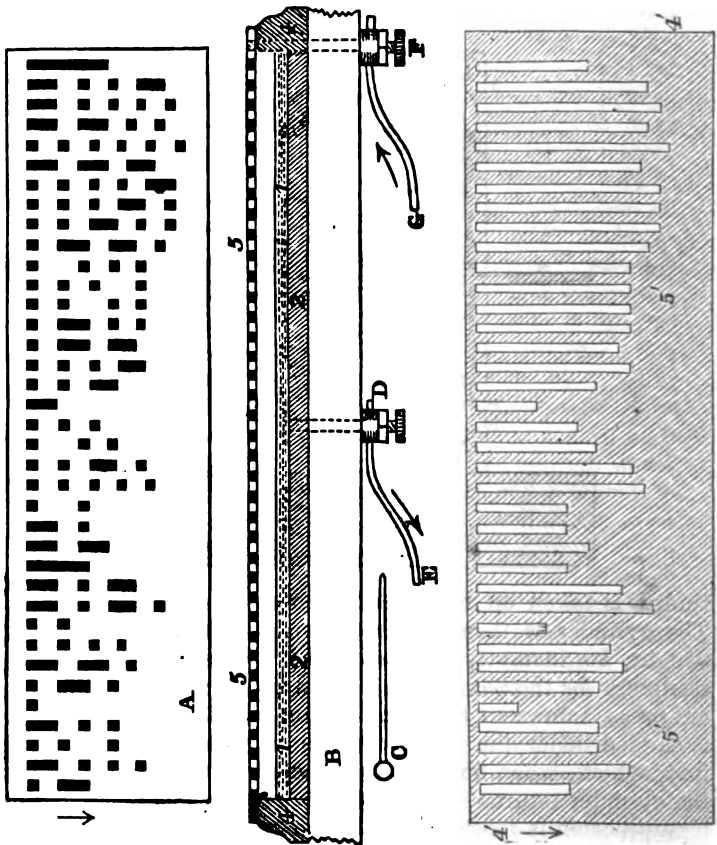

that when the guide plate, 5' 5', is put over the form, A, each opening is directly over its appropriate letter, and is a little longer than the length of the letter. 4' and 4' is the wooden frame, to which the guide plate is secured. The ends of this frame are seen in the sectional figure at 4 4, and the guide plate at 5 5; the dark portions of which represent the partitions, and the blanks the openings. It will be observed here that the plate 5 5, resting upon the wooden frame 4 4, is completely insulated from the brass letter plate 1 1 and 2 2; the blank space between them showing the separation. It is, however, necessary that the guide plate should be connected with one pole of the battery, and the letter plate with the other pole. For this purpose a brass screw, r, passes up through the table B; and through 4 into the guide plate 5 5. The head of the screw has a small hole through it, for passing in the end of the copper wire c from the battery, and a tightening screw below, by which a perfect connection is made. At d is another screw, passing through the table and into the letter plate 2 2. To the head of this screw is also connected another copper wire, e, extending to one of the poles of the battery.

This instrument, when used, occupies the place of the key or correspondent, in the description heretofore given of the register. The circuit is now supposed to be complete, except between the guide plate 5 5, and the letter plate 2 2. Now, if a metallic rod or pencil, c, be taken, and the small end passed through one of the openings in the shield above the letter, its point will rest upon the ivory; and if it be gently pressed laterally against the side of the opening of the guide plate, at the same time a gentle pressure is given to it upon the ivory, and then drawn in the direction of the arrow 4', it is obvious that when the metallic current reaches, for instance, the short line of letter B, the circuit will be closed; and the fluid will pass from the battery along the wire to the screw r, then to the guide plate, along the plate to the rod, thence to the metallic short line of letter B, thence to the letter plate below, thence to the screw, from the screw to the wire, and thence to the battery. When the point has passed over the short metallic line, it reaches the ivory, and the circuit is broken.

The next and most important improvement was the manipulating key, represented by fig. 9, which has been in universal use since the first year of the establishment of the experimental line in 1844. This was called the "lever key."

A A is the block or table to which the parts are secured; B represents the anvil block; J the anvil, screwed into the block, both of brass; B is another block, for the stop anvil K, and the

standard for the axis of the lever *c*; *L* is the hammer, and is screwed into the lever, projecting downward at *v*, almost in contact with the anvil *J*; *R* is another screw of the same kind, but in contact with the anvil *K*, when the lever *c* is not pressed upon. Under the head of each of these two screws are tightening screws, which permanently secure the two hammers to any adjusted position required for the easy manipulation of the lever *c*; *D* is a spring which sustains the arm of the key up, preventing the hammer *L* from making contact with the anvil *J* when not in use; *G* is a screw connecting with the brass block *B*, and *F* a screw connecting with the block *E*. To these screws the two wires, *i* and *H*, of the battery are connected. Now, in order to put it in operation, it is necessary to bring the hammer *v* in contact with the anvil *J* for so long a time,

Fig. 9.

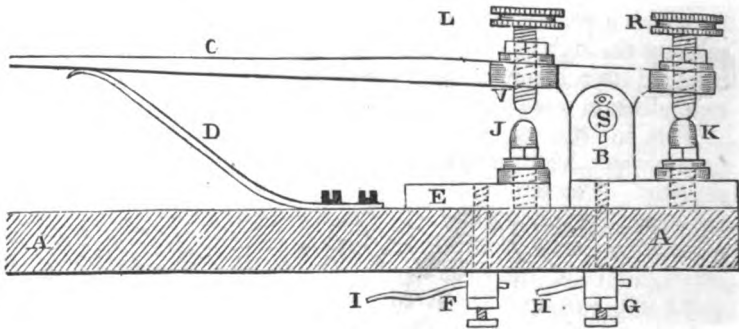

and at such regular intervals as are required by the particular letters of the communication. When the key is pressed down, the fluid passes from the battery to the wire *H*, then to the screw *G*, then to the block *B*, then to the lever *c*, at the axis *S*, then to its metallic anvil *J*, then to its screw *F*, then to the wire *I*, and so to the battery.

In order to give some idea of the rapidity with which the circuit may be closed and broken, and answered by the motion of the lever, fig. 10 is here introduced to explain its construction and arrangement. The platform is shown at *T*, and the upright at *S*, to which the coils of the electro-magnet *A* are secured by a bolt with its thumb nut *E*; *D* a projecting prong of the soft iron, and *C* the armature attached to the metallic lever *B*, which has its axis or centre of motion at *K*, in the same manner as the electro-magnet of the register, *R* being the standard through which the screws pass; *O* is the steel spring secured to *R*, by a plate *V* upon it, and the screw *N*; *L* and *M*

are adjusting screws, for the purpose of confining the motion of the lever *B* within a certain limit. *P* is a wire with an eye at the top, through which the end of the steel spring passes, with a hook at the other end passing through the lever. The wire *q* from one of the coils is connected with the plate *u*, at the top of the standard *R*. As the standard *R* is of brass, the plate *u*, the axis of the lever of steel, and the lever *B* of brass, all of them being metals and conductors of the voltaic fluid, they are made in this arrangement to serve as conductors. *i* is the wire proceeding from the other coil, and is extended to one pole of the battery. The wire *h*, coming from the other pole, is soldered to the metallic spring *J*, which is secured to the up-

Fig. 10.

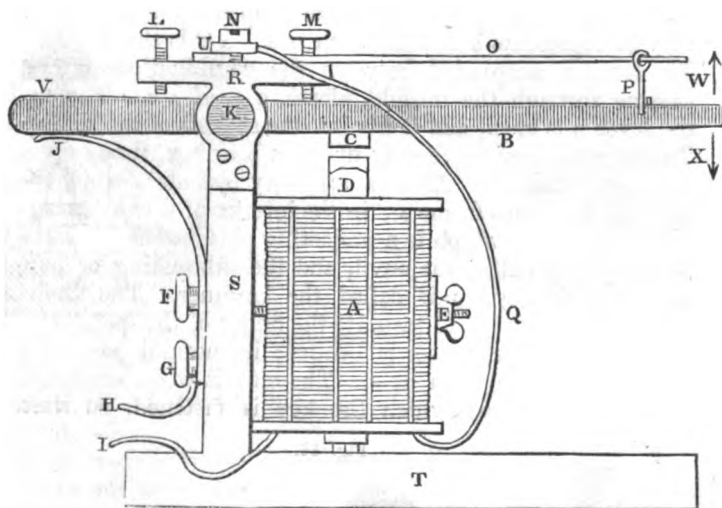

right *s* by means of the adjusting thumb screws *F* and *G*. This spring is extended to *J*, where it is in contact with the lever *B*. We have now a complete circuit. Commencing at *i*, which is connected with one pole of the battery, thence it goes to the first coil; then to the second; then by *q* to *u*, the plate; then to the standard *R*; then to the steel screw *K*; then to the steel axis; and then to the lever to the point *J*, where it takes the spring to *h*, the wire running to the mercury cup of the other pole of the battery.

The battery being now in action, the fluid flies its circuit; *D* becomes a powerful magnet, attracting *C* to it, which draws the lever down in the direction of the arrow *X*. But since *B*

and *J* are a part of the circuit at *v*, and since, by the downward motion at *x*, and the upward motion at *v*, the circuit is broken at *J*, the consequence is, that the current must cease to pass, and *D* can no longer be a magnet; the lever at *v* returns to *J*, and the current again flows.

Such were the original instruments and plans of the early telegraph in America. I will now present illustrations of some of the more modern apparatuses, with such descriptions of them as may be necessary to enable the reader to understand their respective parts.

MODERN LEVER KEYS.

The lever key, represented by fig. 9, is in principle still in practical use on all the Morse telegraphs on both continents. Fig. 11 represents a key in much use. *A C* is the brass frame. The lever is suspended between the combination screws *h h*, passing through the upright pieces, *e e*, of *A C*. The axle of the lever *D* is steel, and it fits into the sockets of the screws *h h*. To make the key move easy upon its bearings, many operators improperly use oil. At *E* is an ivory cylinder, which passes through the brass frame *A*; in the interior of *E* is a brass piece, upon the top of which is a projecting platina head. This part of the key is called the anvil, and the subtending or hanging nipple to the lever *D* is called the hammer. The knob *v* is made of ivory, so as to insulate the finger of the operator. The heaviest part of the lever is behind; its normal position is, as seen in the figure, open at *E*. The circuit wires are connected under the table on which the key is fastened, so that the

Fig. 11.

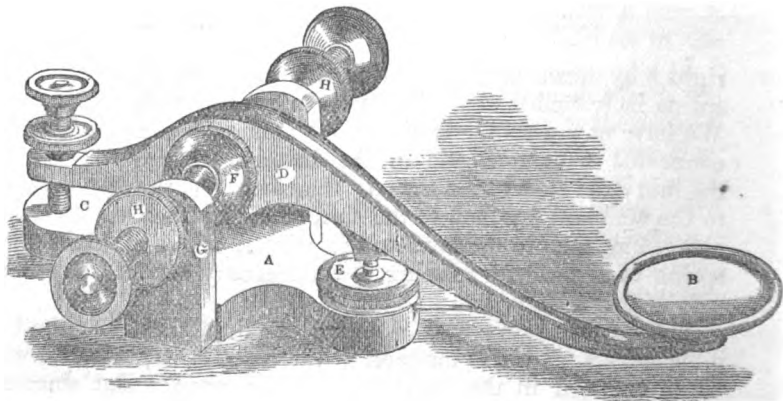

current will pass through the brass frame Λ C G , the screw H H , the axle of the lever at F , with the lever to the hammer and anvil at E , and then with the wire attached beneath. When the operator presses upon B , the lever descends and closes the circuit at E , the weight of the back part of the key elevates the front. This key requires an apparatus known as a "circuit closer," which will shortly be described.

Fig. 12 represents a key with the "circuit closer" attached.

Fig. 12.

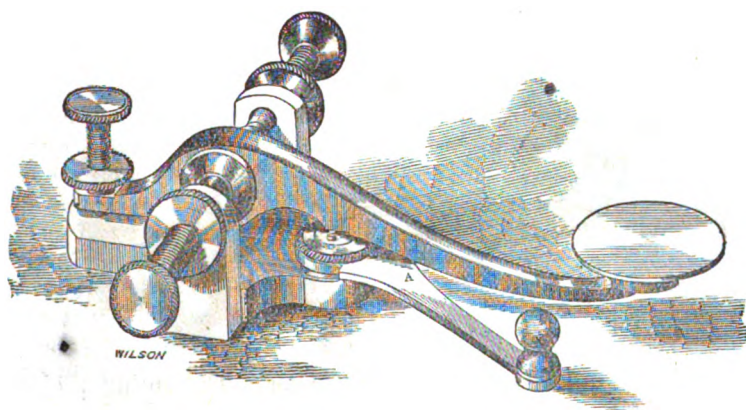

Λ is a small lever, with an ivory knob on its end. In the present position of the lever Λ the circuit is closed, but to move it to the left at right angles with the key lever the circuit will

Fig. 13.

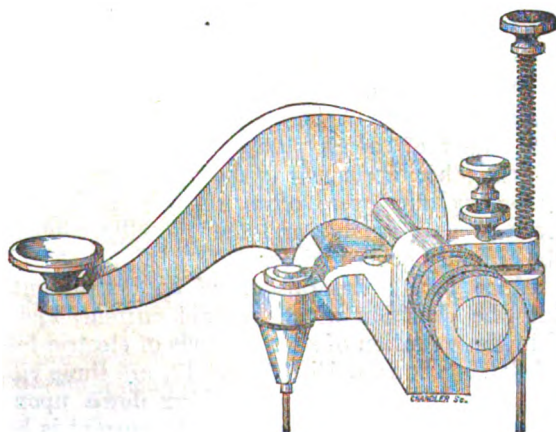

be opened. In swinging the arm to a position at right angles, a brass spring is brought firmly against a pin of steel attached to the anvil.

Fig. 13 is a closed lever key. The front part is heavy, and closes the circuit at the anvil by its own weight. When manipulated, the operator lifts the lever instead of pressing upon it, as with the other forms of keys. In order to make it an "open lever," a spiral spring is placed around the high screw behind; the spiral spring will force down the back part and elevate the front, as seen in the figure.

Fig. 14 represents another form of key, having in front an insulated elevating spring, to raise the lever from a contact at

Fig. 14.

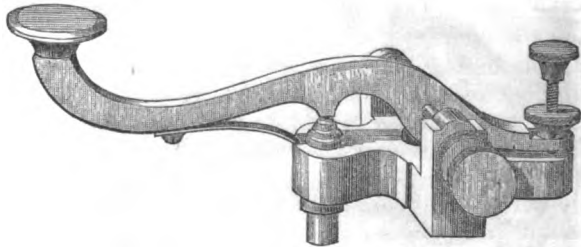

the anvil unless pressed by the finger. The spring projects from the frame and holds up the lever, as seen in the figure. The spring of course is insulated, so as not to form a part of the circuit.

THE EARLY CIRCUIT CHANGERS.

Having explained the lever key, it becomes necessary to describe the different arrangements for opening and closing the circuit, and the plans adopted for the transference of the polarity of the circuits.

In the early history of the telegraph, it was common to have an arrangement of mercury cups, with bent wires connecting one with the other, according to the necessities of the occasion. These mercury cups were often auger-holes bored into the table or a piece of plank, and the metallic connectors used were the ordinary copper wires.

I introduce here a description of an instrument used for reversing the direction of the voltaic current, and which is applied in the operation of several kinds of electric telegraphs.

The following figures, 15, 16, and 17, are three views of the instrument as it appears when looking down upon it in its three changes. First, that in which the current is broken and

the needle vertical; second, in which the circuit is closed and the needle deflected to the right; third, in which the circuit is closed and the needle deflected to the left. Each figure has, in connection with the pole changer, the battery, or any other generator of the electric fluid, represented by *n* and *p*, and the electrometer represented by *e*. In each of the figures, the circles numbered 1, 2, 3, 4, 5, 6, 7, and 8, represent cups filled with mercury let into the wood of the platform, and made permanent. The small parallel lines terminating in these cups represent copper wires or conductors.

A, fig. 15, represents a horizontal lever of wood, or some insulating substance, with its axis supported by two standards, *B* and *C*, by which it can easily vibrate. *D* represents an ivory ball, mounted upon a rod, inserted in the lever, and extending a few inches above it. It serves as a handle, by which to direct the elevation or depression of either end of the lever. Both ends of the lever branch out, presenting two arms each. Through each arm passes a copper wire, insulated from each other. The left-hand branches support the wires which connect the mercury cups 1 and 4, and 2 and 3 together; the right-hand branches support the wires which connect the cups 5 and 7, and 6 and 8, together. The ends of these wires directly over the mercury cups are bent down, so that they may freely enter their respective vessels when required; the other wires are permanently secured to the platform. The

Fig. 15.

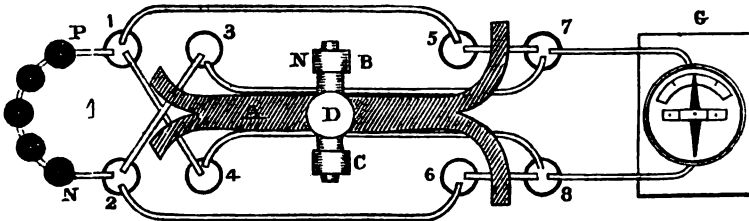

position of the lever is now *horizontal*, and the bent ends of the wires, which it carries, are so adjusted, that none of them touch the mercury; consequently, there is no connection formed between the battery and electrometer, and the needle is *vertical*. The ivory ball, it will be observed, is directly over the centre of the axis, and in that position required to break the circuit. Thus, the wires 2 and 3, 1 and 4, 5 and 7, 6 and 8, are each out of the mercury, and the circuit being broken the fluid cannot pass.

Fig. 16 represents those connections which are formed when the left-hand side of the lever is depressed, immersing in the mercury those wires supported by it. The ball and lever are omitted for the better inspection of the wires. Now the circuit is closed, and the current is passing from P of the battery, to the mercury cup, 1; then along the cross wire to 4; to 8; to the coils of the multiplier, deflecting the needle to the *right*: then to 7; to 3; then along the cross wire (which is not in contact with wire 1 and 4) to 2; to the N pole of the battery. The arrows also show the direction of the current. It will be observed that the cups 5 and 7, and 6 and 8 are not now in

Fig. 16.

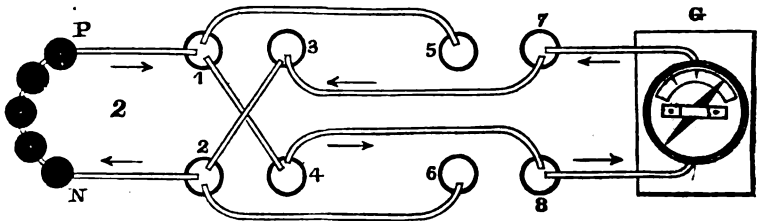

connection, and consequently the current cannot pass along the wires 1 and 5, and 2 and 6.

Now, if the ball *d* is carried to the right, a new set of wires, fig. 17, are immersed, and those represented in fig. 16, as in connection, are taken out of their cups. The fluid now passes from P of the battery, to the mercury cup 1; to 5; to 7; to the coils of the multiplier, deflecting the needle to the *left*; then it passes to cup 8; to 6; to 2; and then to the N pole of the battery; the arrows representing the direction of the current. It will now be found that the cups, 2 and 3, and 1 and 4, are not in connection; and consequently, the current cannot pass along the wires, 3 and 7, and 4 and 8.

Thus, it will appear, that by carrying the ball *d* to the left,

Fig. 17.

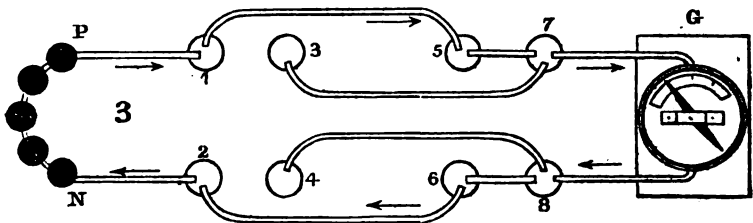

the needle is deflected to the *right*; then, by carrying the ball to the right, the needle is deflected to the *left*; and when the ball is brought to the vertical position, the needle is *vertical*. These three changes enter into the plans of several electric telegraphs, which are to be hereafter described.

MODERN CIRCUIT CLOSERS.

In later years, the mercury cups have been abandoned, and metallic connectors are used in their stead. Fig. 18 represents a circuit closer, that accompanies the keys represented by fig. 11.

The base *A* is made of wood; between *A* and *C* is a brass pin serving as a stop to the lever *B*. The lever moves around a fulcrum at the centre; *c c* are the top ends of the elongated screws, *D D*, the lower ends of which are attached to the circuit wires; these screws pass through the table board. The line wires enter the holes as seen in the larger ends of the screws, and the binding screws *E* hold the wires with a good metallic contact; *F* is a spring which causes the lever to press upon the upper ends of *D D*. This is the normal position of the circuit closer. The key is open and the current passes from the wire into the long screw *D* at *E*, thence through the lever from *c* to *c*, thence down *D* to the line wire. If the operator desires to manipulate with his key, it is necessary to move the lever *B* from *c*, to the pin by which the circuit is broken, and then upon pressing the lever of the key, the circuit is again closed. Whenever the operator has finished manipulating, it is necessary to close the circuit by placing the lever arm of fig. 18 in its present position.

Fig. 18.

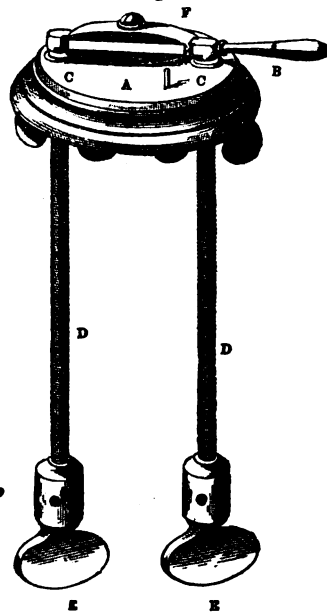

Figs. 19, 20, 21, and 22, are circuit closers of different forms, but constructed upon the same principle as fig. 18.

Like arrangements are used for the transference of circuits from one apparatus to another. There are a variety of arrangements for effecting this end. Figs. 23 and 24 are in common

use in America. On the Western Union lines, Mr. Anson Stager has applied a very ingenious circuit changer, having metallic straps across a board, and a hinge lever to transfer

Fig. 19.

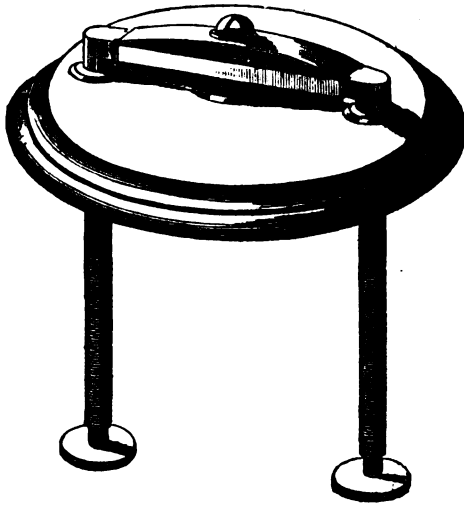

Fig. 20.

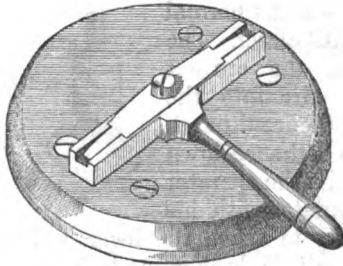

Fig. 21.

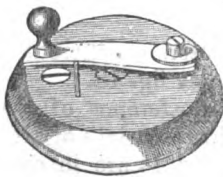
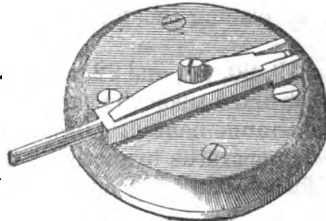

Fig. 22.



the current from one place to another. It is a compound "switch board," and is fastened upon the wall, so that any operator in

Fig. 23.

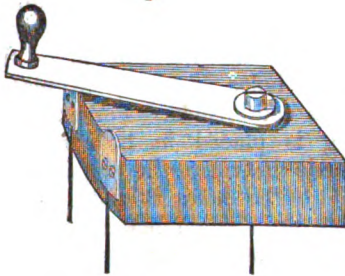
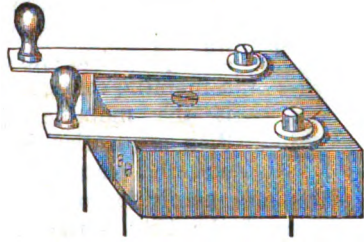

Fig. 24.



the room can see from his place the arranged circuits. Fig. 23 is a single, and fig. 24 is a double switch.

NOTTEBOHN'S CIRCUIT CHANGER.

An ingenious contrivance was gotten up by Mr. Nottebohn,

Fig. 25.

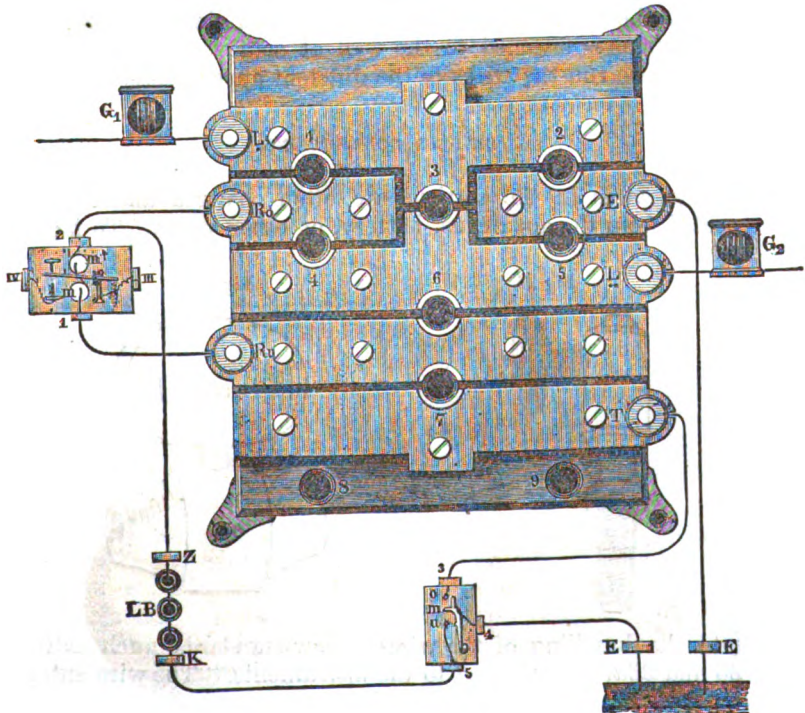

director-general of the Prussian telegraphs, for the purpose of changing the circuits. Fig. 25 represents the circuit changer used on the Prussian lines. It consists of six brass pieces, or plates, insulated by means of ivory, and situated upon a square piece of plank. Between the plates are seven holes, numbered

Fig. 25a.



from 1 to 7. By means of the metallic plug, fig. 25a, placed in one of the holes, between two plates, a metallic connection is established. For example, if the metallic plug is placed in hole number 3, a connection is made between the upper plate and the plate 4, 6, L . The holes 8 and 9 in the plank are merely to contain the plugs when not in use. By means of the bolt I the line wire coming from one side is fastened—for example, from Berlin through I to the side going to Minden—and at E the wire leading to the earth is fastened. Letters G^1 and G^2 are vertical electrometers; R O is connected with the apparatus by means of numeral 2; and R U by means of numeral 1; and by means of bolt 3 with L . The copper end of the battery K is connected with the earth, and the zinc end with the instrument. In the writing apparatus, the wire of the local battery proceeds from bolts III and IV. E E are the earth plates. The board containing these circuit connections is fastened to the wall at some convenient place, and thence run the wires to the different apparatuses.

BINDING CONNECTIONS.

The wires in the stations are often changed and disconnected from the apparatus, battery, or other parts. To facili-

Fig 26.

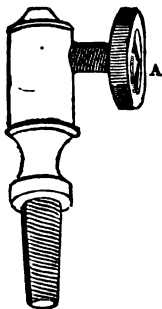
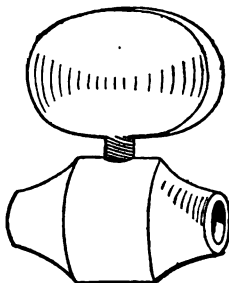

Fig. 27.



tate the handling of the wires, screw-standards, such as fig. 26 and 26a, are attached to the instruments. The wire enters

a hole, and the screw A, to the right, binds the wire fast. Figs. 27 and 28 are for uniting two ends of the wire together.

Fig. 26a.

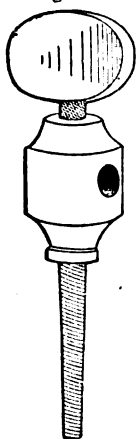
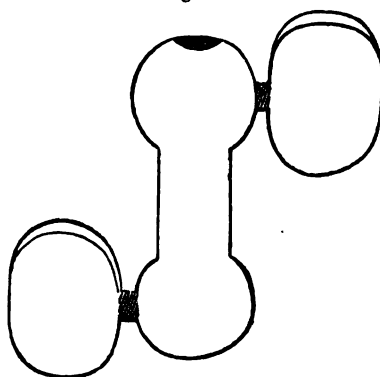

Fig. 28.



Figs. 29 and 30 are for making the connection between the wires and the arms of the battery.

Fig. 29.

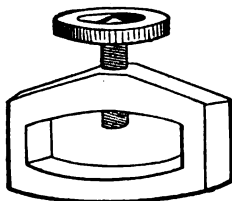
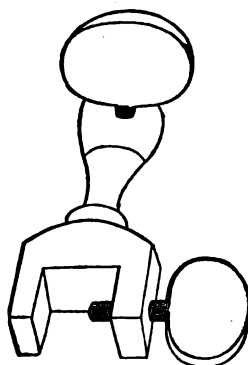

Fig. 30.



THE ELECTRO-MAGNET OF 1844.

The next telegraphic apparatus which I propose to describe is the electro-magnet of 1844. It is one of the most important parts of the system, and one that every operator should well understand. There are two kinds, the register magnet and the relay magnet. The name of the latter is not strictly proper, but in its understood sense it means an electro-magnet

that is placed in the main circuit for the purpose of putting into action another, a local or secondary circuit. In the understood sense, as a telegraphic technicality, I use the term relay magnet.

The magnet first used on the American telegraph in 1844 was as represented by figs. 31 and 32, and was thus described by Mr. Vail :

“ The electro-magnet is the basis upon which the whole invention rests in its present construction ; without it, it would entirely fail. As it is of so much importance, a detailed account will be given of the construction of the electro-magnet, as used for telegraphic purposes. A bar of soft iron, of the purest and best quality, is taken and made into the form presented in fig. 31, which consists of four parts—viz., *A F* and *A F* are the two legs or prongs of the magnet, of a rounded form, and bent at the top, approaching each other toward the centre, where the ends of each prong, without touching, turn up and

Fig. 31.

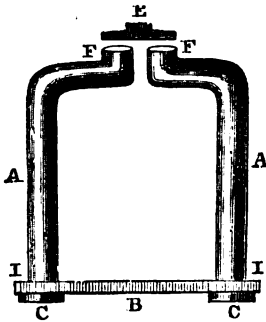
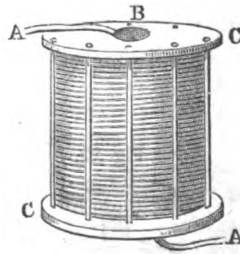

Fig. 32.



present flat, smooth, and clean surfaces, level with each other, at *F F*. The other end of these prongs or legs is turned smaller than the body, on the end of which is a screw and nut, *c c*. These ends pass through a plate of iron, *B*, of the same quality, at *I* and *I*, until they rest upon the plate at the shoulder produced by turning them smaller. They are then both permanently secured to the plate *B* by the nuts *c c*, and the whole becomes as one piece. This arrangement is made for the purpose of putting on the coils or taking them off with facility. The form most common for electro-magnets is that of the horse-shoe ; and is simply a bar of iron bent in that form. *E* represents a small flat plate of soft iron, sufficiently large to cover the faces of the two prongs *F* and *F*, presenting on its under

side a surface clean and smooth, and parallel with the faces, *F* and *F*.

The coils or helices of wire which surround the prongs *A A*, necessary to complete the electro-magnet, consist of many turns of wire, first running side by side, covering the form upon which the spiral is made, until the desired length of the coil is obtained; the wire is then turned back, and wound upon the first spiral, covering it, until the other end of the coil is reached, where the winding began; then again mounting upon the second spiral, covers it, and in the same manner it is wound back and forth, until the required size of the coil is attained.

The coil is wound upon a form of the size (or a little larger) of the legs of the magnet, and when the coil is completed, the form is taken out, leaving an opening in the centre, *B*, into which the prongs may freely pass. Fig. 32 represents a coil constructed in the manner described. *A* and *A* are the two ends of wire which are brought out from the coils. The one proceeds from the centre of the coil, and the other from the outside. *c* and *c* are circular wooden heads, on each end of the coil, and fastened to it by binding wire, running from one head to the other around the coil. The wire used in constructing it, as heretofore mentioned, is covered in the same manner as bonnet wire, and saturated or varnished with gum shellac. This preparation is considered necessary, in order to prevent a metallic contact of the wires with each other. Such a contact of some of the wires with others encircling the iron prong would either weaken or altogether destroy the effect intended by their many turns. If the wires were bare instead of being covered, the electric fluid, when applied to the two ends, *A* and *A*, instead of passing through the whole length of the wire in the coil as its conductor, would pass laterally through it as a mass of copper, in the shortest direction it could take. For this reason they require a careful and more perfect insulation. Two coils are thus prepared for each magnet, one for each prong *A* and *A*, fig. 31."

Such was the construction of the magnets in 1844. The wire was large, and one pair of coils weighed 185 pounds. Since then the ingenious spirit of the age has reduced the size and weight; the usual weight does not exceed from one to two pounds; the wire is very fine, and well covered or insulated with silk. The mechanism has very much changed; so much so, in fact, that the telegrapher unacquainted with the facts in the case, would not suppose the magnets above described ever belonged to the telegraph.

THE MODERN RELAY MAGNET.

The modern relay magnets are of many forms of construction. I will describe one of them in detail. Fig. 33 represents the magnet as it sets upon the table, with its wooden base, having at each corner binding posts. The line wire enters the hole in the post *A*, and is bound by the screw in its top. To the post *A* is soldered the copper wire leading to the spools or coils of the magnet. One end of the insulated wire that surrounds the coils is joined to the wire that leads to the post *A*; the other end of the spool wire is in the same manner connected with the post *M*. The current from the line wire enters the station and follows the conductor to the post *A*, thence through the magnet coils, thence to post *M*, and thence to the battery.

The local circuit is united to the posts *B* and *C*; the lower

Fig. 33.

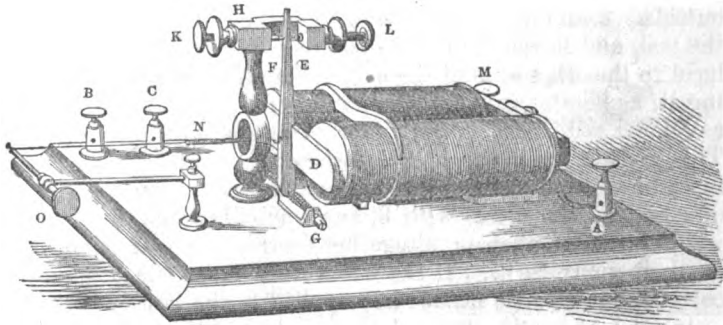

end of post *B* is connected by a wire beneath the base to the metallic frame *G*; the other local post, *C*, is connected by a wire underneath to the metallic standard *H*; the armature *D* is attached to a brass upright lever, on the side of which, near *E*, is fixed a piece of platina; *K* is an adjusting screw, with an insulating point, *F*, made of ivory; *L* is another adjusting screw, with a platina point *E*. The upright lever attached to the armature *D* does not touch the brass arm *H*. Suppose a current is transmitted over the line wire; it traverses the coils and produces magnetism in the cores of the spools. The armature *D* is then attracted toward the magnet, and the upright lever is brought into contact with the platina point *E*, which closes the local circuit. The current from the local battery will then flow with the copper wire conductor to the post *B*,

thence to the metallic axle frame *e*, thence up the lever of the armature, thence with the screw *e*, thence with the brass work *h*, thence underneath the board to post *c*, and from there through the register magnets to the other end of the battery. This completes the local voltaic circuit. If the circuit be broken at *e*, the local battery fails to act. Every time the current is transmitted over the line by the contact of a key at a distant station, the current flows through the relay magnet the local circuit is then closed, and the local battery current:

Fig. "4.

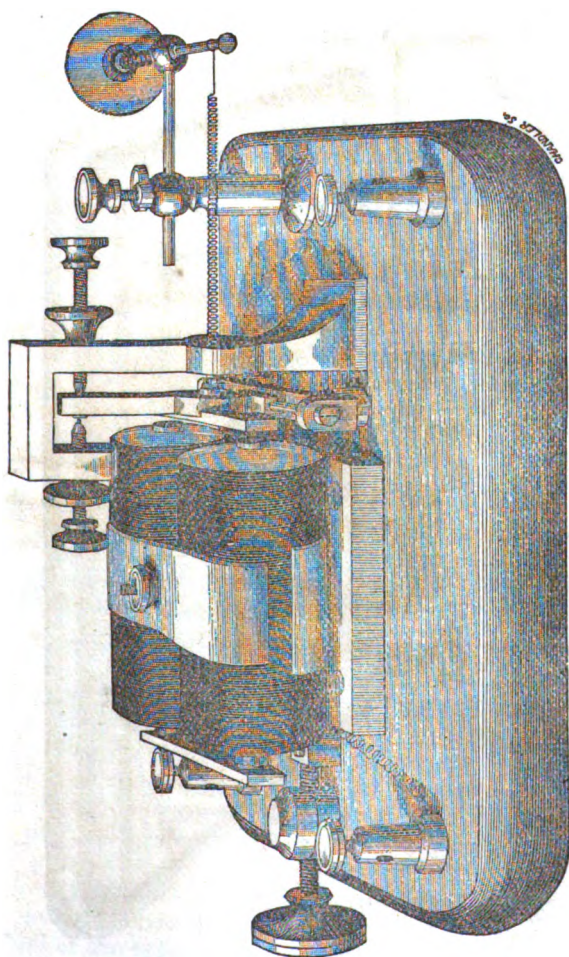

passes through the register magnets, which causes the pen lever to mark upon the paper. If the magnetism in the cores be too strong, the armature *D* is drawn farther from their ends by the adjusting screw *o*, to the end of which is attached a silk thread or cord. This cord is tied to one end of a spiral spring, *n*, the other end being fastened to the armature lever. These explanations are, I presume, sufficient to enable the reader to understand the application of the relay magnet in the telegraph apparatus.

Fig. 35.

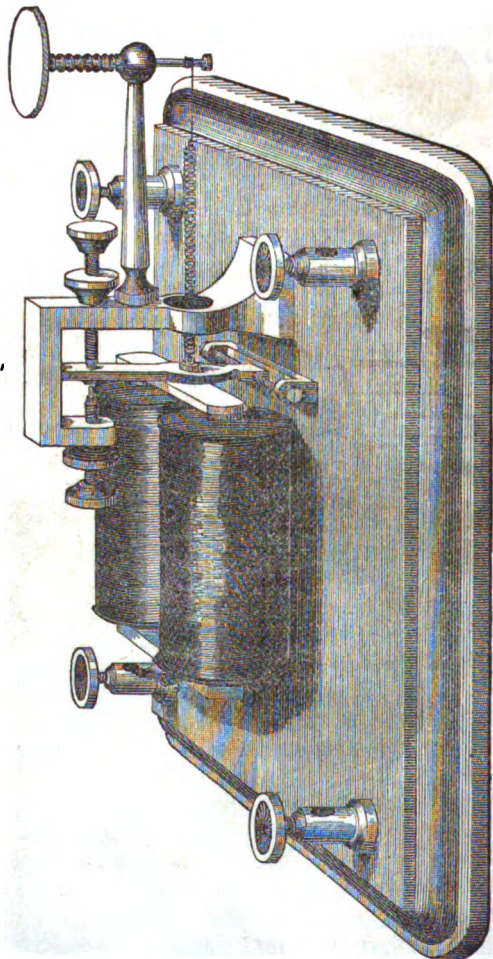
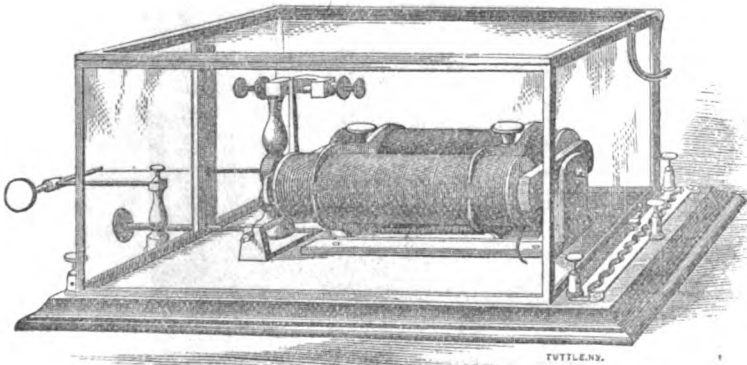

Fig. 34 represents a relay magnet with adjustable coils. By turning the screw at the left of the engraving, the spools or helices can be drawn from the armature or placed closer to it, as circumstances require. It is best for the armature lever to be poised on its axle, and when the adjusting screws are all arranged, it is easier to remove the coils backward or forward by the one screw, than to readjust the armature lever by the three screws *L*, *k* and *o*, as seen in fig. 33. This valuable improvement was invented by Mr. Thomas Hall, of Boston, who has been engaged in the manufacture of telegraphic apparatuses since the commencement of the enterprise. By his ingenious mechanical skill many very valuable improvements have been made, and the telegrapher has realized many advantages in the service by the application of Mr. Hall's contrivances in the different departments of the art.

Fig. 35 is another form of a relay magnet, manufactured by the same gentleman. The line wire is connected to the various parts beneath the base board.

Fig. 36 is another improved relay magnet, gotten up by

Fig. 86.



those energetic telegraphers, Messrs. Chester and Brothers. The coils of this magnet are covered with a glass case, set in a brass frame with hinged top. The coils are moveable by an adjusting screw outside of the glass. At one end of the board is attached a paratonnerre, with the earth wire connected to the centre post. The line wire is fastened to the posts at each end of the paratonnerre. If the lightning enters the station, it passes from the inner to the outer brass plate between the two posts in preference to traversing the coils. If the wire from one end of the brass plate is not connected with the earth,

and both ends lead on to other stations on each side, the plus lightning will pass over to the exterior or right-hand brass plate and follow the earth wire from the centre post, seen in the figure. This excellent combination is worthy of the highest appreciation.

Fig. 37 is a pocket relay magnet ; it is small, and weighs about one pound. The coils are fitted in a little case, and all the arrangements for wire connections are perfect. On the side is attached a small key, so that an operator can manipulate

Fig. 37.

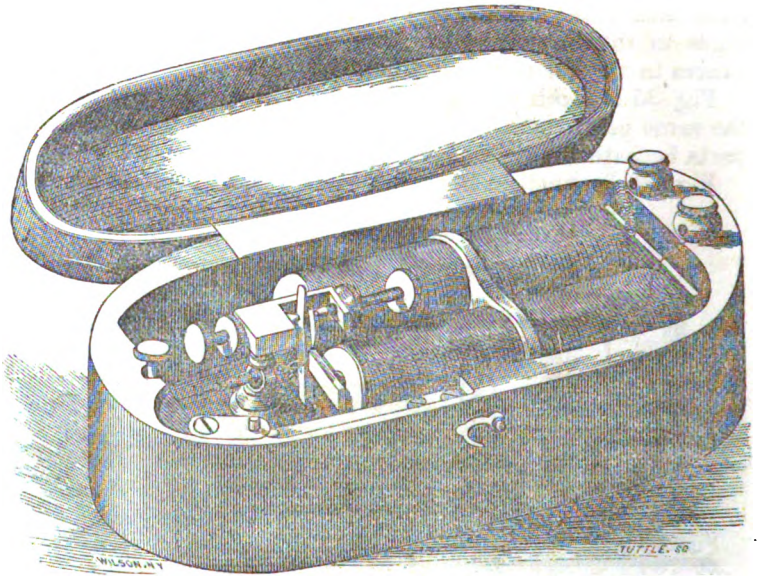

with it as perfectly as with the larger keys of the station. The binding posts at the right hand end receive the line wires. The current traverses the coils, and the armature lever makes the telegraphic sound, and the expert operator is thus enabled to transmit and receive information with the same perfection, common at the stations. Repairers find this miniature magnet of great value.

Fig. 38 represents what has been commonly known in America as the Bain sounder. It is the ordinary relay magnet, with one or more glass disks attached to it as seen in the figure. It was used as a call magnet on the lines not having the patented authority to work the Morse system. The Bain

lines applied this magnet, so that the stations could hear the "call" when wanted by a distant station. The armature

Fig. 38.

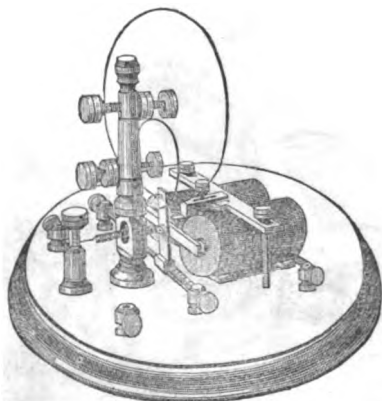

striking upon the glass disk, a distinct and intelligible sound was made.

THE RECEIVING REGISTER.

The next apparatus to be described is the register, an instrument of simple construction, and perfectly effective in the recording of the dispatch. The register herein before described was a complete success. Subsequent improvements have added to the exactness of the mechanism, and rendered it as reliable and durable in its service as possible to be attained in the art.

Fig. 39 represents an improved register, exhibiting the clock-work and magnets. The pen-lever is seen in the figure with the steel point projecting upward; the magnets are fastened to the upright standard. The wire from the local battery connects with the front standard, and it is then carried, as seen in the figure, to the front coil; after surrounding it and the rear spool, it is united with the rear standard. The wire surrounding these magnets is not so fine as the wire used for the relay magnets. The local battery circuit commences with the platina end of the battery, and runs to the relay magnet, and passes through the connections at that instrument as before described; thence it comes to the register, and through the coils; it then runs to the zinc end of the battery, which completes the local circuit. Whenever the relay magnet, fig. 34, attracts the armature, the local circuit is closed at E, and

the local current traverses the coils of the register magnet, fig. 39, which generates magnetism in the cores, the armature is then attracted down, which elevates the other end of the lever, and the pen point is thus caused to puncture the ribbon paper,

Fig. 39.

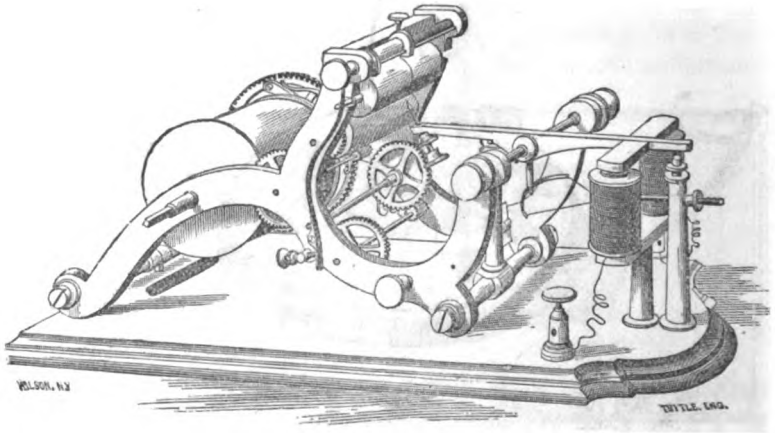

as seen in fig. 40. The clockwork being in motion, the paper is drawn through by the grooved rollers, and thus a clear piece of paper is continually presented for indentation by the pen point. The clockwork is wound up by the key, seen in the figure, and it is set in motion or stopped by the stop slide, the handle of which is seen at the centre and under the mechanism.

Fig. 40.

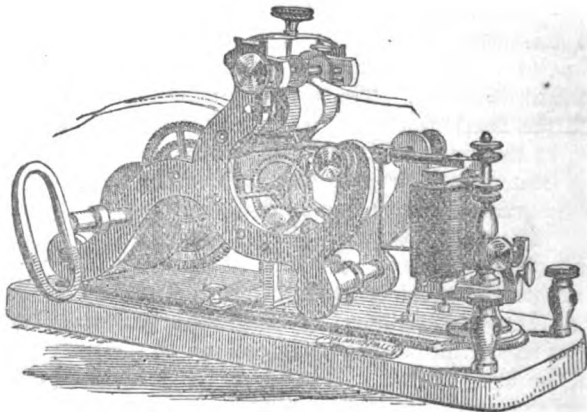

Fig. 41 represents an improved register, manufactured by the Messrs. Chester. It is one of beautiful finish and perfection of mechanism. The base is of pure Italian marble, highly

Fig. 41

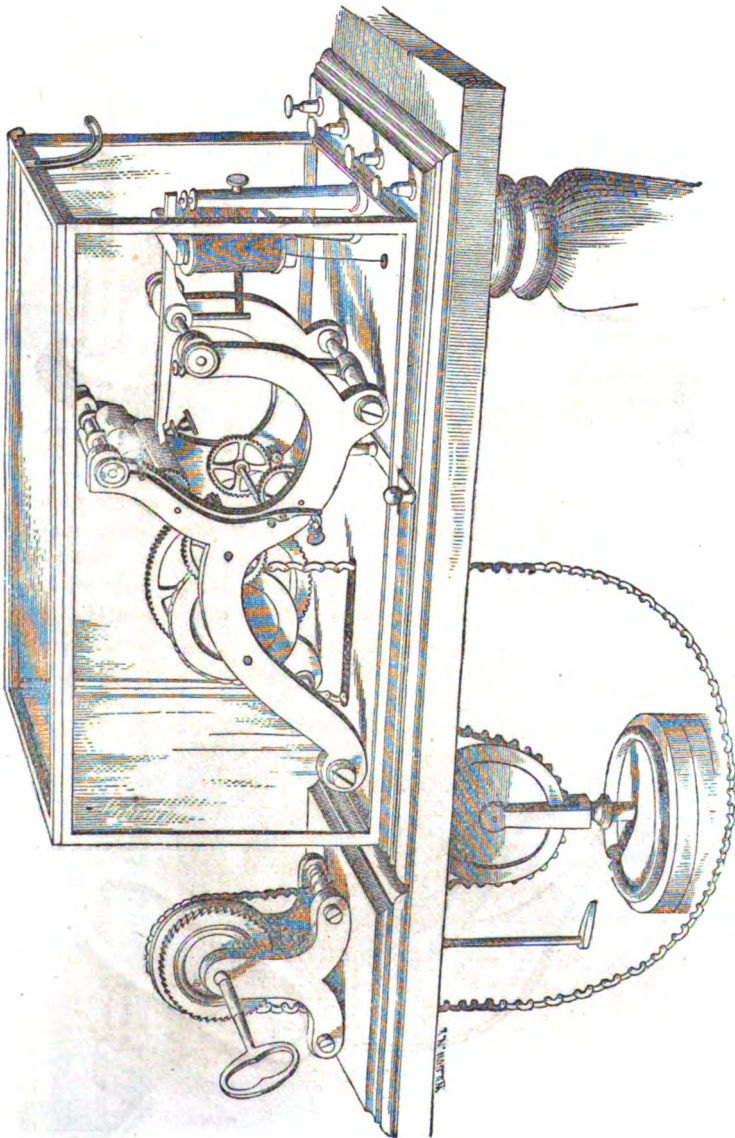
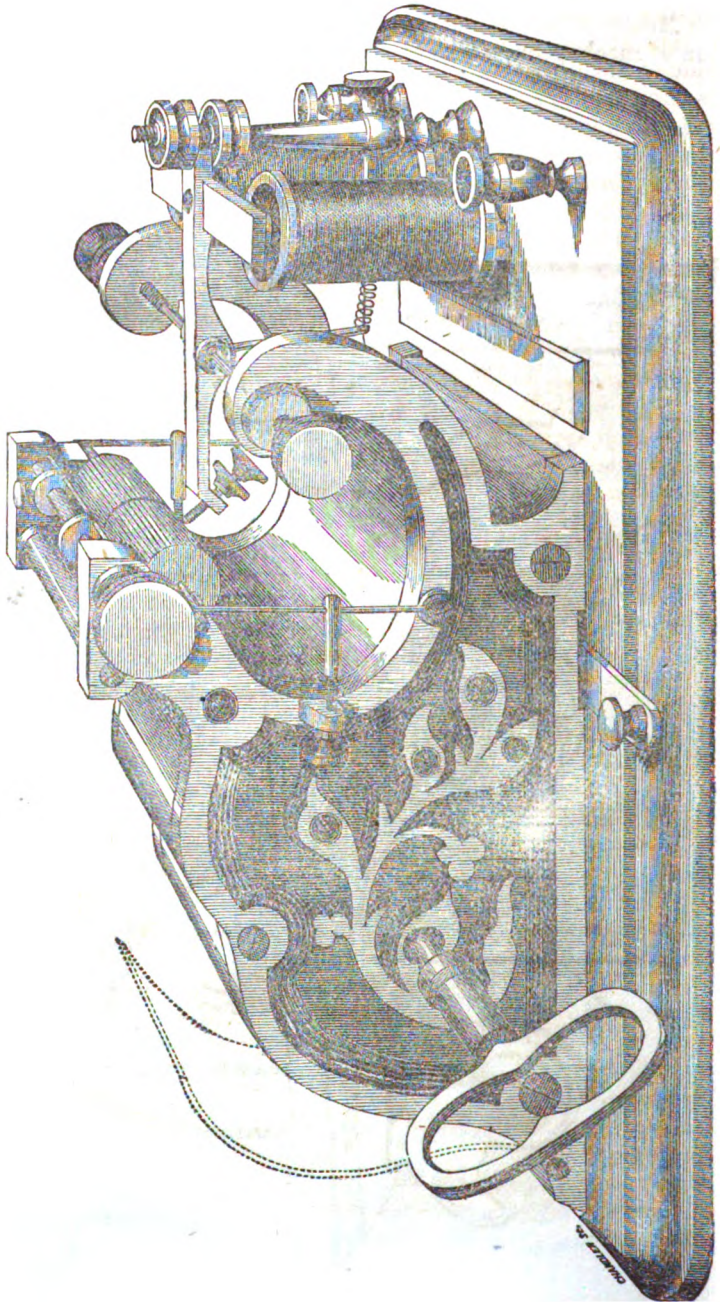

Fig. 42.



polished. It is encased in glass, with an opening at the top with a hinge.

The arrangement for winding up this register is on the outside of the glass case, which can be done while the clockwork is running. The pen-lever is also arranged to open and close another main circuit serving the purposes of a "repeater." The wire connections are made outside with the binding posts, as seen in the figure.

Fig. 42 is a closed register, manufactured by Mr. Thomas Hall. The clock-work is enclosed in a brass or iron case. In front is a hinged opening, which, when open, occupies the position indicated by the dotted lines to the left. This register has been extensively used on railway telegraph lines, and it has given universal satisfaction. The clock-work once put in order remains so for a very long time, and the wheels are thus enabled to move with the desired celerity. It has all the necessary and improved appliances for adjusting and regulating the different parts, and the whole embraces everything necessary to render it useful and economical.

THE TELEGRAPHIC SOUNDER.

Fig. 43 represents a sounder, as now successfully used in many of the American telegraph stations. The register, with all its clock-work, marking on paper, and accompaniments, has been laid aside at the leading stations, and this simple apparatus has taken its place. The coils are the same as those

Fig 43.

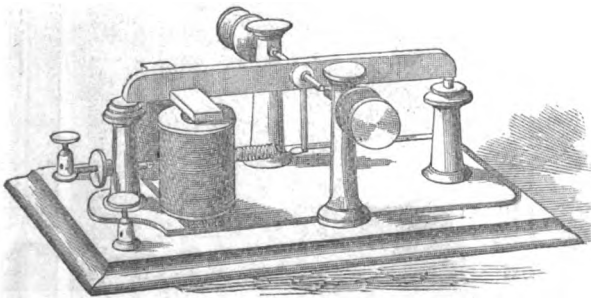

used in the register; the lever is made substantial, and the local current causes the magnet cores to attract the armature with great strength, and thus a good clear sound is made, by which the operator in any part of the room can hear and understand what is communicated by any other station on the whole line.

Fig. 44 is another form of the sounder ; the lever is adjusted at the end by the spiral spring, seen in the figure. Some operators prefer one mode of construction, and others choose a different kind ; some prefer a heavy sound, others can hear more distinctly a lighter tone. The sense of hearing is not the same with all operators, and it is but natural that there should be a difference in choice as to the sounder.

Of all the mysterious agencies of the electric telegraph, there is nothing else so marvellous as the receiving intelligence by sound. The apparatus speaks a language, a telegraphic language, as distinct in tone and articulation as belong to any

Fig. 44.

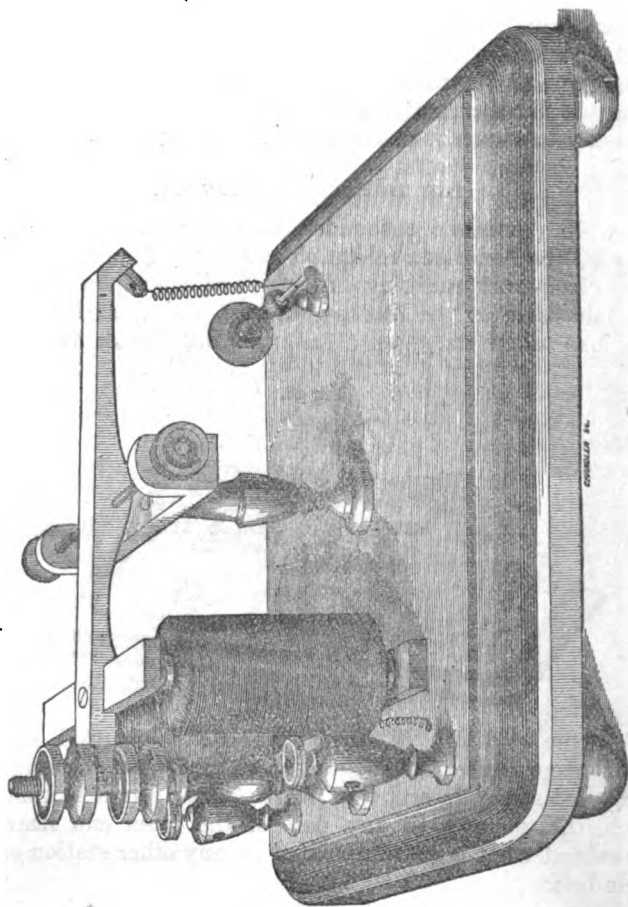

tongue. The sound that makes the letter, is as defined in the one as it is in the other. An operator sits in his room, perhaps some ten feet from his apparatus, and he hears a conversation held between two others, hundreds of miles distant, and perhaps the parties conversing are equally as far apart. He hears every word; he laughs with them in their merriment, or perhaps sympathizes with them in their bereavements. The lightning speaks, and holds converse with man! What can be more sublime!

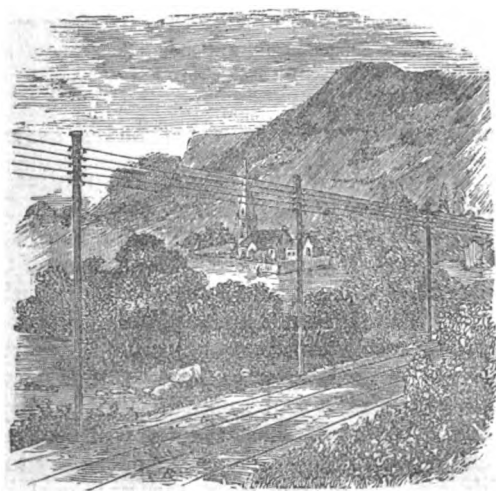

INTERIOR OF AN AMERICAN TELEGRAPH STATION.

CHAPTER XXXIII.

Receiving Department of a Telegraph Station—The Operating or Manipulating Department—Receiving Dispatches by Sound—Incidents of the Station—Execution of an Indian Respited by Telegraph.

RECEIVING DEPARTMENT OF A TELEGRAPH STATION.

In the present chapter I will explain the routine of the interior of a telegraph station on the American lines. The public reception rooms are sometimes on the lower floor, so that entrance may be direct from the street. At many of the offices, it is in the second story. Figure 1 represents the public reception room in the Cincinnati Station. Behind the counter are seen the receiving clerks; in front is the public department. At convenient places are arranged tables or stands on which are placed pencils and blanks to be used in writing dispatches to be transmitted. A copy of these blanks will be found at the end of this chapter, marked A. It is not necessary to write the dispatch with ink, and in fact it is the universal practice to use the ordinary lead pencil; the paper used, is generally soft and receives the lead so that the writing can be easily read. When the dispatch is handed to the receiver at the counter, the words are counted and endorsed on its margin. No regard is given to the signature, and the receiver may know it to be fictitious, yet he promptly receives the dispatch and the money for its transmission. The blank form A has been adopted recently on several of the American lines, but it is not compulsory to use them. In short, messages are received and sent from any one offering, whether upon the company's blanks or upon any other kind of paper.

Fig. 1.

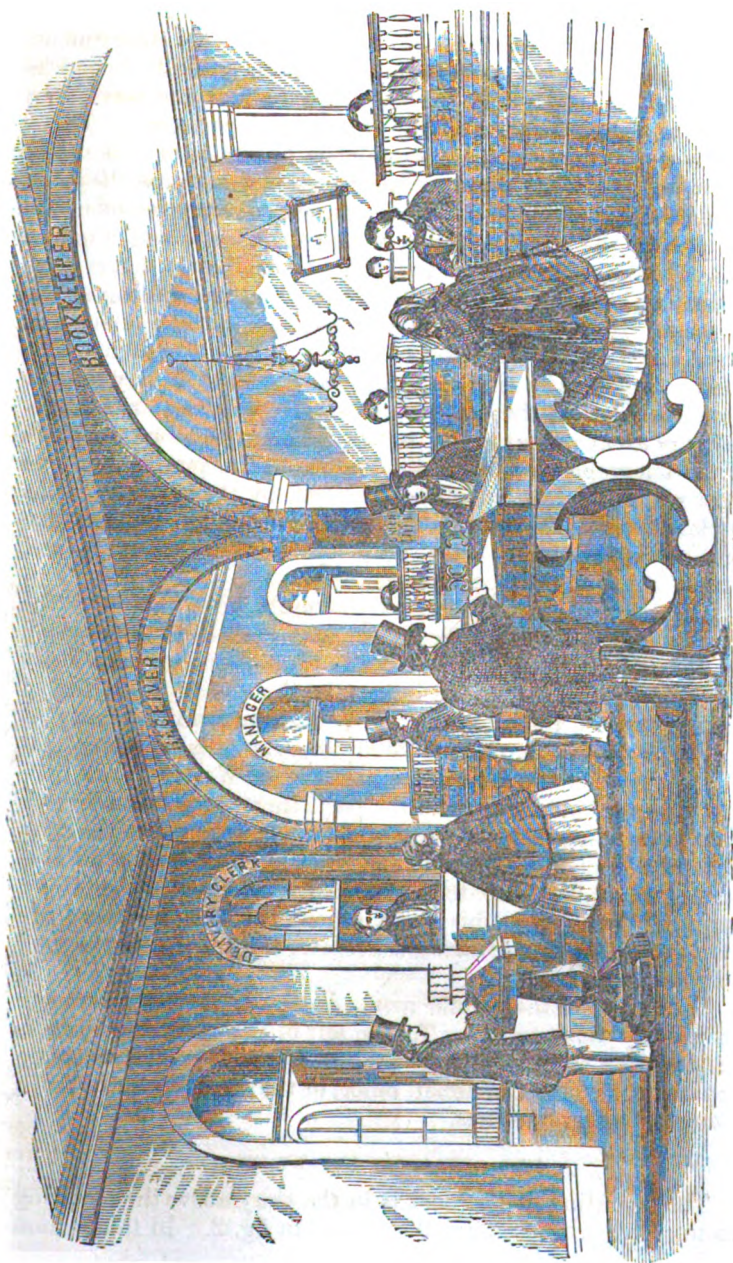

The general reception room represented in the figure, was arranged by Mr. Charles Davenport, who, for many years, has been energetically engaged in that most difficult department, discharging his trust with more than ordinary skill. There is no part of the telegraph service more tedious and perplexing than the administration of the reception department. Thousands of people send their dispatches hundreds of miles, and know not but what they go and their answers come the same instant. Far in the West, I have known persons to offer dispatches for the extreme East, some twelve or fifteen hundred miles distant, passing over the lines of some half a dozen companies, and expect the answer while they are waiting at the counter. It becomes the duty to explain to the anxious and uninformed public the cause of the delay of a dispatch. The answer is generally anxiously expected, because it may refer to some speculation, the death of a friend or relative, or of something of great import to the parties. The mysterious workings of the telegraph are but little known to the public, and the most respectful tone has to be observed, by the receiver, in his explanations. The service of the receiver is an art, and one that requires more than ordinary powers, manners and amiability of disposition to discharge.

I have not deemed it necessary to embrace in this work the fiscal details of the telegraph, nor is it easy for the European reader to comprehend the celerity and economy practically observed on the American lines. In the city of New York I have estimated the number of dispatches transmitted daily at 2,430, or for the year about 739,000. But this is in the great metropolis. At Cincinnati, a city in the far West, where a little more than a half century in the past, there were but a few log huts to be seen, now the telegraph largely enters into the commercial affairs of the public, and through that station an average of about 950 dispatches pass daily, or about 385,000 per annum. To execute this great amount of business there are employed 12 operators, 2 book-keepers, 2 receiving clerks, and 14 messengers.

To the left of the public room, in fig. 1, is the messenger or delivery department. To the left of the receiving space is the cashier's room. Such is the arrangement of the reception department of the Cincinnati office, of the great Western Union Range of telegraph lines.

THE OPERATING DEPARTMENT.

The operating department is in the story above the receiving room. A representation will be seen in fig. 2. In this station

Fig. 2.

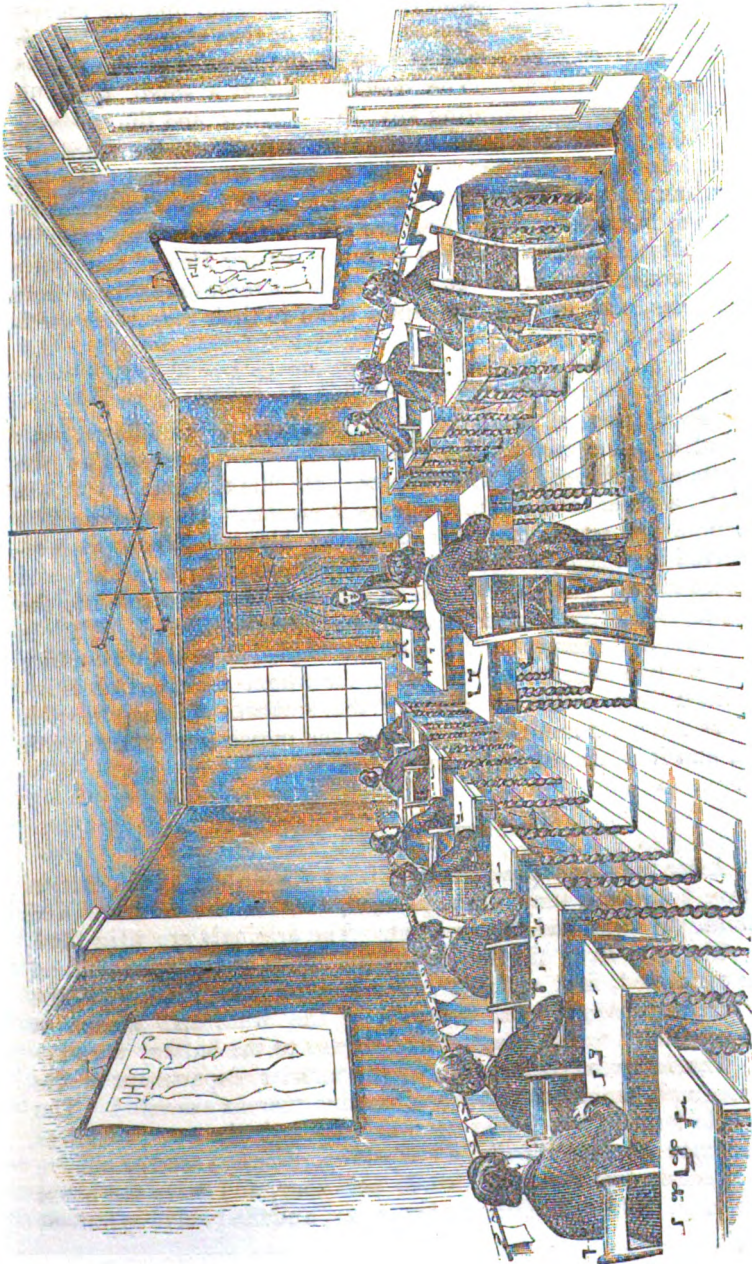

the sounding apparatuses are wholly used. No recording mechanism is there employed. The register, and the moving ribbon paper are no more to be seen in that station. The engraving gives a very correct idea of the interior of the manipulating department. The operator sits at a small table, on which is the manipulating key, the magnet, and the sounder.

These three pieces of mechanism constitute the whole of the telegraphic apparatus. The operator transmits by the key and receives by the sounder. As fast as the dispatches are received from the public, they are sent to the operating room by a pulley, and then distributed to the proper files of the routes over which they are to be sent. The operator takes them from the files, and, in turn, transmits them to their respective destinations.

RECEIVING DISPATCHES BY SOUND.

The process of receiving by the operator is as follows, viz. : He has before him on the table the blanks represented by the form B, at the end of this chapter. He fills the blank with the date, address, and the message as it arrives. He receives it by sound, and writes it in ink upon the blank. When thus received it is sent to the delivery department by a pulley, and there it is registered, placed in an envelope, entered into the messenger's book, and then immediately delivered. This is the whole formality, and the time occupied does not necessarily exceed five minutes, if the party for whom the dispatch is intended lives within a square of the station. If the dispatch thus delivered requires an answer, the messenger returns with it, and it is immediately forwarded.

INCIDENTS OF THE STATION.

After the dispatches received from the public at the station have been sent, they are registered, that is, the names to and from, the date, and the amount. The originals are then filed.

The wire from the line enters the office at the window, and is connected, first with the paratonnerre, and then with the "circuit changer" on the side of the wall, and thence it is conducted to the magnet and thence to the battery wires.

The foregoing description of the interior department of the telegraph, embraces the whole routine therein executed. The whole formality is based upon celerity and the most complete promptness. Practically, an expert operator can send or receive by sound, two thousand words per hour, and serve ten hours per day, making 20,000 words per day, and the twelve operators,

represented in fig. 2, can send and receive 240,000 words per day. According to this data, it will be seen that the capacity of the line for transmission of intelligence is equal to the most expert manipulation. It is in contemplation, by some lines, to apply mechanism by which the general news may be sent with more rapidity than by hand. Contrivances have been made by which twenty thousand words per hour may be successfully transmitted. The day is not far distant when this will be a daily achievement. Ten years ago, each line in the station had the most complete set of apparatuses. The register for receiving was manufactured with the greatest care, so that the clock-work would move with perfection, the paper had to be adjusted on cylinders, and the various appliances had to be arranged in a particular form. The operator put the machinery in motion, and he read from the paper the dispatch as it was slowly received. He read aloud, and the copyist, near by, wrote it down with a pencil; and when thus finished, it was handed to the copying clerk, whose duty it was to copy it on the forms as represented by *b*. It was then enveloped and handed to the messenger for delivery.

Expert telegraphers soon dispensed with the copyists, then followed the dismissal of the copying clerks, and soon thereafter, the recording instruments were laid aside. The first operator to practically receive by sound was Mr. Edward F. Barnes, of New York, and at that day it was regarded as a feat most extraordinary. But now it is the daily practice in all the leading telegraph stations in America—only the local or interior stations have in use the recording apparatuses.

If a telegrapher cannot receive, perfectly, by sound, he is not regarded as an expert, and the ambitious young man ceases not until he has fully attained that degree of perfection.

Some years ago, as president of a telegraph line, I adopted a rule forbidding the receiving of messages by sound. Since then the rule has been reversed, and the operator is required to receive by sound or he cannot get employment in first class stations. At the Cincinnati stations, for example, there is not a recording apparatus, and, of course, if an operator cannot read the language uttered by the mysterious messenger, as transmitted over the wires, he cannot have employment there. No mistakes are made, and, in fact, many experts have informed me that the ear proves to be more reliable than the mechanism.

It is quite common for the operator to take with him, when he proceeds upon the line to repair it, a small pocket magnet, and when he arrives at the place of difficulty, to communicate back to his office. Some operators care not for even this small

mechanism, preferring to manipulate by striking the wires together, and then receive with the tongue, by placing one wire above and the other wire below it. The voltaic pulsations will be felt on the tongue, and the dots and dashes are thus recognized as to time by the sense of feeling. In latter days practice has gone farther, and a second party has received intelligence from a distant office by noticing the quivering of the nerves of the tongue of another, who had the wires attached as above described. These latter modes of receiving, of course can never be used for practical telegraphing, but they are common in the repairing service, and have been for several years.

EXECUTION OF AN INDIAN RESPITED BY TELEGRAPH.

In 1850, a mail carrier, by the name of Colburn, was murdered on the plains some three hundred miles from the white settlements, on the Santa Fé trail. The mail bag was found near the dead body, open, and its contents scattered on the ground. Among the papers were found several drafts for money, which fact alone was sufficient to demonstrate that the murder had been committed by the Indians.

Search was made by the whites, and different articles were found in the possession of an old Indian, who was supposed to be the murderer. He was arrested, and so was his whole family. They were brought to Jefferson City, in the State of Missouri, that being the place of the nearest court of jurisdiction. At the first term thereafter the Indian was put on trial, and a son of the old man was called as a witness. He denied that his father had anything to do with the murder, or that he had been accessory either before or after the fact. He confessed to the murder, and declared that he alone had committed the horrid deed! The father was released, and so were the whole family, except the son. He was placed on trial. He again confessed to the murder, which was satisfactorily proved by some circumstantial evidence. He was convicted of the murder, and sentenced to be hung on the 14th of March, 1851. The old Indian and his family were then conducted back, by the Government, to their home in the wilds of the West, leaving the youthful, but brave son behind, never again to be seen by them.

But, a few days before the time fixed by the law for the execution of the young Indian, whose name was See-see-sah-ma, it was discovered that he was not the murderer of the mail carrier, and that he had confessed to the crime, in order to save his father from dying, other than by the hands of the Great

Spirit. He wanted him to die brave in battle, or calmly in the midst of his own family. The fact of this self-sacrifice for an aged parent, was satisfactorily substantiated to the citizens of Jefferson City, too late to save his life by the ordinary means of communication with the United States Government. The documents were prepared as speedily as possible, praying the President to respite the execution, having in view a consideration of the recently-discovered evidence. On the 13th of March, the day before the fatal hour, the papers had not been forwarded, and there was no hope for the poor doomed Indian, except through the telegraph. All the facts in the case were transmitted to me at St. Louis, with the request for me to aid in getting a respite. In the evening of that day, about eight o'clock, I sent to the President the following dispatch, viz. :

To His Excellency,

MILLARD FILLMORE, PRESIDENT OF THE UNITED STATES.

I am requested to petition your excellency for a respite of the execution of the Indian, See-see-sah-ma, to take place tomorrow at Jefferson City, for the term of thirty days. Documents substantiating his innocence are being prepared, and will be forwarded to Washington.

TAL. P. SHAFFNER.

The above dispatch reached the President that night, but too late to be answered before the closing of the telegraph lines. On the morning of the 14th, the day of execution, at half-past nine o'clock, the President sent to the office his answer, viz. :

WASHINGTON, *March 14, 1851.*

To Tal. P. Shaffner, St. Louis:

The Marshal of the District of Missouri, is hereby directed to postpone the execution of the Indian, See-see-sah-ma, until Friday, the 18th of April.

MILLARD FILLMORE.

One copy of this message was sent via Philadelphia, Pittsburg, Cincinnati, Louisville, to St. Louis, a distance of some 1100 miles, reaching its destination at ten minutes before ten o'clock, A. M. Another copy was sent via New York, Buffalo, Cleveland, Chicago to St. Louis, a distance of about two thousand miles, reaching the latter city at five minutes after ten o'clock, A. M. Another copy was sent via Baltimore, Wheeling, Louisville, Nashville, Cairo to St. Louis, a distance of some sixteen hundred miles, reaching St. Louis at eight minutes after ten o'clock, A. M. Each of these copies was transmitted over the wires of four different companies, and on the latter route was ferried over the Ohio river in an ordinary skiff.

The execution of the Indian was to take place at noon. Thousands of people had assembled around the gallows to see the poor red man of the forest launched into eternity in atonement for the awful crimes, supposed to have been committed by him, namely, the murdering of a fellow-being and robbing the great mail of the United States. There was no time for delay, and I hastened to search for the Marshal, who resided in the city of St. Louis. I found him in his office, some half mile distant from the telegraph station. He wrote the following dispatch to his deputy at Jefferson City :

To Mr. W. D. Kerr, Deputy Marshal :

You are hereby directed to postpone the execution of the Indian prisoner, See-see-sah-ma, till Friday, the 18th of April.

JOHN W. TWITCHELL,

United States Marshal, District of Missouri.

The above order, accompanied with the President's, was sent to Jefferson City twenty minutes after ten A. M. The Indian, who was already on his way to the place of execution, was returned to his cell in the prison, his coffin stored away, and the multitude dispersed.

The President received the evidence, and the Indian, See-see-sah-ma, was spared the ignominy of a public execution upon the gallows.

A.

WESTERN UNION TELEGRAPH COMPANY.

No. 2.] TERMS AND CONDITIONS ON WHICH MESSAGES ARE RECEIVED BY THIS COMPANY FOR TRANSMISSION.

The public are notified, that, in order to guard against mistakes in the transmission of messages, every message of importance ought to be repeated by being sent back from the station at which it is to be received to the station from which it is originally sent. Half the usual price for transmission will be charged for repeating the message. This Company will not be responsible for mistakes or delays in the transmission or delivery of un-repeated messages, from whatever cause they may arise; nor will it be responsible for damages arising from mistakes and delays in the transmission or delivery of a repeated message, beyond an amount exceeding two hundred times the amount paid for sending the message; nor will it be responsible for delays arising from interruptions in the working of its Telegraphs, nor for any mistake or omission of any other Company over whose lines the message is to be sent to reach its place of destination. All messages will hereafter be received by this Company for transmission, subject to the above conditions.

SEND THE FOLLOWING MESSAGE SUBJECT TO THE ABOVE CONDITIONS:

185

To

B.
WESTERN UNION TELEGRAPH COMPANY.
 CONSOLIDATED LINES.

~~~~~  
**TERMS AND CONDITIONS ON WHICH MESSAGES ARE RECEIVED BY THIS COMPANY FOR TRANSMISSION.**

The public are notified, that, in order to guard against mistakes in the transmission of messages, every message of importance ought to be repeated by being sent back from the station at which it is to be received to the station from which it is originally sent. Half the usual price for transmission will be charged for repeating the message, and while this Company will, as heretofore, use every precaution to insure correctness, it will not be responsible for mistakes or delays in the transmission or delivery of repeated messages, beyond an amount exceeding five hundred times the amount paid for sending the message; nor will it be responsible for mistakes or delays in the transmission of un-repeated messages from whatever cause they may arise, nor for delays arising from interruptions in the working of its Telegraphs, nor for any mistake or omission of any other Company, over whose lines a message is to be sent to reach the place of destination. All messages will hereafter be received by this Company for transmission, subject to the above conditions.

**A. STAGER, Gen. Supt, Cleveland, O.**

**I. R. ELWOOD, Sec'y, Rochester, N. Y.**

---

To..... 185

By *Taberagh*..... 185

---



---



---



---



---



---



---



---



---



---

# THE MORSE TELEGRAPH ALPHABET.

## CHAPTER XXXIV.

Composition of the American Morse Alphabet—The Alphabet, Numerals, and Punctuation—The Austro-Germanic Alphabet of 1854—European Morse Alphabet of 1859.

### COMPOSITION OF THE AMERICAN MORSE ALPHABET.

THE alphabet of the American Morse telegraph is composed of dots, dashes, and spaces, arranged upon mathematical scale. A student of the profession should at the beginning of his studies arrange a scale of measurement of his writing or sound by the telegraph pen. The length of the mark or of the space upon the ribbon paper will be precisely the same as the length of the contact made with the key. If the student will first arrange a scale, determining the style of writing he desires, and place it before him as he manipulates with the key—observing the letter made upon ribbon paper of the register before him—he can in a short time perfect the measurement of his manipulation to the scale adopted.

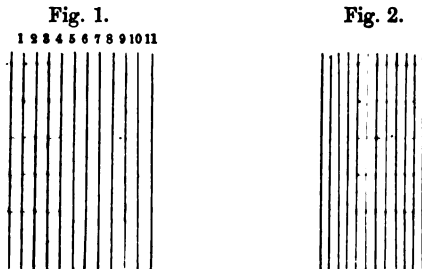

Fig. 1 represents a coarse hand-writing, and fig. 2 a fine hand. Whether the dots, spaces, and dashes be long or short, they should be uniform; and unless they are thus methodically made, the writing cannot be perfect. In the use of the



foregoing scale, to make an *a*, one of the spaces is used for the dot, one for the space, and two for the dash. For the letter *b*, the first dash occupies two spaces, then follows one for the space, then one for a dot, the next for a space, the next for the dot, the next for a space, and the next for a dot, making —... *b*. For the letter *c*, the first space for the dot, the next for a space, the next for a dot, the two next for the space, and the next for the dot. The letter *r* is the reverse of the letter *c*. The letter *t* is composed of a dash occupying two spaces, as the dash of the letter *a*; the letter *l* is a double *t*, or a dash occupying four consecutive spaces; the figure 6 occupies alternate spaces, being six dots and five spaces; the figure 5 is composed of three *t* dashes, each separated by a space; the cipher 0 is composed of three *t* dashes, joined, or six divisions of the scale.

## AMERICAN MORSE ALPHABET.

|   |       |   |       |   |      |
|---|-------|---|-------|---|------|
| A | ·—    | J | —...· | S | ...· |
| B | —...· | K | —·—   | T | —    |
| C | ·—·   | L | —     | U | ·—·  |
| D | —·—   | M | —·—   | V | ·—·— |
| E | ·     | N | —·    | W | ·—·— |
| F | ·—·   | O | ·—·   | X | ·—·— |
| G | —·—·  | P | ·—·—  | Y | ·—·— |
| H | ·—·—  | Q | ·—·—  | Z | ·—·— |
| I | ··    | R | ·—·   | & | ·—·— |

## NUMERALS.

|   |       |   |       |
|---|-------|---|-------|
| 1 | ·—·—· | 6 | ·—·—· |
| 2 | ·—·—· | 7 | —·—·— |
| 3 | ·—·—· | 8 | —·—·— |
| 4 | ·—·—· | 9 | —·—·— |
| 5 | —·—·— | 0 | —     |

## PUNCTUATION.

|                 |   |       |               |   |         |
|-----------------|---|-------|---------------|---|---------|
| Period          | . | ·—·—· | ‡ Exclamation | ! | ·—·—·   |
| Comma           | , | ·—·—· | Apostrophè    | ' | ·—·—·—· |
| Colon           | : | ·—·—· | Paragraph     | ¶ | —·—·—   |
| * Interrogation | ? | —·—·— | Italics       |   | ·—·—·   |

In learning to make the alphabet, the student should first make the dots, such as *i*, *s*, *h*, *p*, &c. The spaced letters *c*, *o*, *r*, *y*, and *z*, require much care to make them correctly. In making the *c*, as with the other spaced letters, it is important not to occupy more than two spaces between the last two dots. Between words the space should be equal to three lines, or one third greater than the space used in the spaced letters. If the space in the formation of the letter *c* be too long, it will be received as the separation between two words, and it will be taken as *i e*. In ordinary language the error would at once be detected by the receiving operator, but in the use of cipher terms it would not be. On the other hand, the space must not be too short, or the letter *s* will be received. There was a case of serious importance resulting from an error of this kind. A merchant telegraphed from New-Orleans to his correspondent in New-York, to protect a certain bill of exchange about maturing. In the word "protect," the *c* was received as an *s*, and the word was changed to "protest," and the consequence was very serious to the parties interested.

After the student has succeeded in making the dot and spaced letters, he should proceed in the next place to make single dashes, then the compound dashes, such as *l*, &c. After he is perfect in making the latter, then to unite the dots, spaces and dashes for the formation of letters; it will then be easy to write words and sentences.

The following are practical examples :

AMERICAN ALPHABET EXAMPLES.

I N H O C S I G N O V I N C E S .

.....

E N G L A N D E X P E C T S E V E R Y

.....

M A N T O D O H I S D U T Y .

.....

H O N O R T H Y F A T H E R A N D

.....

T H Y M O T H E R .

.....

**T H E U N I O N N O W A N D**

**F O R E V E R .**

**THE AUSTRO-GERMANIC MORSE ALPHABET.**

The Austro-Germanic alphabet adopted for the Morse system of telegraphing is, with some amendments, in the service of nearly all the governments of Europe, and, in fact, wherever the German or Latin letter is used. It is the same language in all Germany, Denmark, Norway, Sweden, France, the Italian States, Sardinia, Spain, Malta, Corfu, North Africa, &c.

This alphabet differs from the combination of the dots and spaced letters of the American telegraphic alphabet. In the European there are no spaced letters, and there is less liability of error than in the American, though it requires more time to transmit by the former than by the latter.

The Austro-Germanic Alphabet of 1854, herewith presented, has been engraved much larger than the usual letter made in the ordinary telegraphic manipulation in Germany. I have copied the alphabet, as officially published by Prussia, Denmark, and the other German states, as used in 1854. Since then the alphabet has been amended, so as to accommodate special letters, common to other languages on the continent. I have added the new combination, as now used all over Europe under the name of the European Morse Alphabet.

**AUSTRO-GERMANIC MORSE ALPHABET OF 1854.**

|          |         |          |         |
|----------|---------|----------|---------|
| <b>A</b> | • —     | <b>J</b> | • — — — |
| <b>Ä</b> | • — • — | <b>K</b> | — • —   |
| <b>B</b> | — • • • | <b>L</b> | • — • • |
| <b>C</b> | — • — • | <b>M</b> | — —     |
| <b>D</b> | — • •   | <b>N</b> | — •     |
| <b>E</b> | •       | <b>O</b> | — — —   |
| <b>F</b> | • • — • | <b>Ö</b> | — — — • |
| <b>G</b> | — — •   | <b>P</b> | • — — • |
| <b>H</b> | • • •   | <b>Q</b> | — — • — |
| <b>I</b> | • •     | <b>R</b> | • — •   |

|   |          |    |            |
|---|----------|----|------------|
| S | •••      | W  | • — — —    |
| T | —        | X  | — •• — —   |
| U | •• — —   | Y  | — •• — — — |
| Ü | •• — — — | Z  | — — — ••   |
| V | ••• —    | Ch | — — — — —  |

NUMERALS.

|   |            |   |             |
|---|------------|---|-------------|
| 1 | • — — — —  | 6 | — •••••     |
| 2 | •• — — — — | 7 | — — — •••   |
| 3 | ••• — — —  | 8 | — — — — ••  |
| 4 | •••• — —   | 9 | — — — — — • |
| 5 | •••••      | 0 | — — — — —   |

PUNCTUATION.

|                     |   |                |
|---------------------|---|----------------|
| •••••••             | ! | — — — •• — — — |
| ; — — • — — • — — • | = | — ••••• — —    |
| , — — — • — — • — — | , | • — — — — — •  |
| : — — — — •••       | / | — — — — — — —  |
| ? •• — — — •••      |   |                |

## EUROPEAN MORSE ALPHABET OF 1859.

|    |         |   |         |    |          |
|----|---------|---|---------|----|----------|
| A  | ·-·     | J | ·-·-·-· | T  | -        |
| Ä  | ·-·-·-· | K | -·-·    | U  | ·-·-·    |
| B  | -·-·-·  | L | ·-·-·   | Ü  | ·-·-·-·  |
| C  | -·-·-·  | M | -·-·    | V  | ·-·-·    |
| D  | -·-·    | N | -·      | W  | ·-·-·    |
| E  | ·       | O | -·-·-·  | X  | -·-·-·   |
| E' | ·-·-·-· | Ö | -·-·-·  | Y  | -·-·-·   |
| F  | ·-·-·   | P | ·-·-·   | Z  | -·-·-·   |
| G  | -·-·    | Q | -·-·-·  | Ch | -·-·-·-· |
| H  | ·-·-·   | R | -·-·    |    |          |
| I  | ·-·     | S | ·-·     |    |          |

## NUMERALS.

|   |         |   |          |
|---|---------|---|----------|
| 1 | ·-·-·-· | 6 | -·-·-·   |
| 2 | ·-·-·-· | 7 | -·-·-·   |
| 3 | ·-·-·-· | 8 | -·-·-·   |
| 4 | ·-·-·-· | 9 | -·-·-·   |
| 5 | ·-·-·   | 0 | -·-·-·-· |

## PUNCTUATION.

|               |   |          |             |     |            |
|---------------|---|----------|-------------|-----|------------|
| Period        | · | .....    | Hyphen      | -   | -·-·-·-·   |
| Semicolon     | ; | -·-·-·-· | Apostrophe  | '   | ·-·-·-·-·  |
| Comma         | , | ·-·-·-·  | Dash        | —   | -·-·-·-·-· |
| Colon         | : | -·-·-·-· | Parentheses | ( ) | -·-·-·-·   |
| Interrogation | ? | ·-·-·-·  | Paragraph   | ¶   | ·-·-·-·    |
| Quotation     | " | ·-·-·-·  | Italics     | —   | ·-·-·-·    |
| Exclamation   | ! | -·-·-·-· |             |     |            |

## EUROPEAN ALPHABET EXAMPLES.

I N H O C S I G N O  
 .. .. .  
 V I N C E S .  
 .. .. .

S U U M C U I Q U E .  
 .. .. .

“ J e d é s i r e q u e  
 .. .. .  
 m e s c e n d r e s r e p o s e n t  
 .. .. .  
 s u r l e s b o r d s d e l a  
 .. .. .  
 S e i n e , a u m i l l i e u d e  
 .. .. .  
 c e p e u p l e F r a n c a i s  
 .. .. .  
 q u e j ' a i t a n t a i  
 .. .. .  
 m é . ”  
 .. .. .

N a p o l e o n .  
 .. .. .

W a h r e W i s s e n s c h a f t  
 .. .. .  
 d u r c h W i s s e n s c h a  
 .. .. .  
 f f t .  
 .. .. .

S t e i n h e i l .  
 .. .. .

## THE RUSSIAN MORSE ALPHABET.

The Russian language, composed of thirty-six letters, has been reduced to a telegraphic alphabet of thirty, as represented by the following engraving. The numerals and punctuation marks are the same as those used on the European Morse telegraph lines. The Morse system of telegraphing is used on all the imperial lines, and dispatches in English, German, and French languages can be transmitted over them.

The dots and dashes have been arranged to economize their use in the formation of letters. For example, the *а* ·—, which is the equivalent of the English broad *а*; the *в* —·, equivalent to the English *v* and the German *w*, a letter much used; the *н* —, equivalent to the English *n*; the *с* —·, equivalent to the English *s*. the *р* ·—, equivalent to the English *r*, &c.

|          |         |          |         |
|----------|---------|----------|---------|
| <b>А</b> | · —     | <b>Ф</b> | — — — · |
| <b>Б</b> | · — · — | <b>Х</b> | · — — — |
| <b>В</b> | — ·     | <b>Ц</b> | — — —   |
| <b>Г</b> | — · — · | <b>Ч</b> | — · —   |
| <b>Д</b> | — —     | <b>Ш</b> | — · · — |
| <b>Е</b> | · ·     | <b>Щ</b> | — — — — |
| <b>Ж</b> | — — · · | <b>Ъ</b> | · · · · |
| <b>З</b> | · · — — | <b>Ы</b> | — · — — |
| <b>И</b> | · · ·   | <b>Ю</b> | · · · — |
| <b>И</b> | — — · — | <b>Я</b> | · — — · |
| <b>К</b> | · · — · | <b>П</b> | · — ·   |
| <b>Л</b> | · — · · | <b>Р</b> | · · —   |
| <b>М</b> | — · · · | <b>С</b> | — · ·   |
| <b>Н</b> | —       | <b>Т</b> | — — ·   |
| <b>О</b> | ·       | <b>У</b> | · — —   |

## MANIPULATING CODE.

Having become familiar with the alphabet, numerals, and arbitrary signals, the next step for the student is the transmission and reception of dispatches. There is no uniform rule governing these formalities; the circumstances pertaining to this part of the service are not the same with all lines. Experts, between themselves, seldom pay regard to the lesser forms. Day by day, accustomed to each other's manipulation, they have their own peculiar rules. On lines where there are employed operators of moderate ability, some forms are observed. In these matters, great changes have taken place on the American lines. In earlier days there were some hundreds of arbitrary signals, but they have become mostly obsolete.

The following are a part of the uniform signals used in America :

## SIGNALS.

|     |                  |     |                                         |
|-----|------------------|-----|-----------------------------------------|
| II  | I am ready.      | SFP | Stop for paper.                         |
| OK  | All correct.     | 1   | Wait a moment.                          |
| GA  | Go ahead.        | 2   | Get answer immediately.                 |
| SSS | Finish Signal.   |     |                                         |
| RR  | Repeat.          | 13  | Do you understand?                      |
| GM  | Good morning.    | 23  | A Message for all.                      |
| GN  | Good night.      | 31  | Don't understand.                       |
| Ahr | Another.         | 33  | Answer paid here.                       |
| Col | Collect.         | 44  | Answer immediately by telegraph.        |
| Pd  | Paid.            |     |                                         |
| W   | Words.           | 77  | Are you ready to receive my message?    |
| DH  | Free.            |     |                                         |
| SFD | Stop for dinner. | 92  | Was message 000 received and delivered? |
| SFT | Stop for tea.    |     |                                         |

Besides the foregoing, different lines have arbitrary signals of their own. Those given above are generally understood throughout America.

On examination at the stations in New York, I find different formalities observed in the transmission and reception of dispatches. I present the following instructions, as the nearest to the practised code.

Suppose, for example, the line extends from Europe to America. Each station has an independent signal. Europe may have the letter E, though, as that letter is composed of but one dot, it would not make an acceptable signal, and therefore another letter would be better. For the illustrations herein, I



will use the letter E as the signal for Europe, and the letter A as the signal for America; M for Marly-la-ville, L for London, N for New York, and P for Philadelphia.

Europe wants America. The former adjusts its magnet carefully, and, finding the line free, calls America, thus, A A A A A E (·- ·- ·- ·- ·- ·-). Having thus called Europe, it pauses for a response. If no answer, it repeats the call four or five times, pausing a reasonable time between calls for America to answer. This process should be repeated from time to time until the answer is received. The operator at the American station may be temporarily beyond the hearing of his call, and hence it is well to repeat it every few minutes.

When America hears the call, it promptly responds I I A (· · · · -). Europe may give signals to America, meaning "I have a message for you," "Are you ready?" &c., and in response America may send the signals G A, meaning "Go ahead." These forms are sometimes used, but in general practice they are obsolete.

Having gotten the response from America, Europe proceeds as follows:

#### EXAMPLE I.

M to P May 10 1752 for Dr Franklin Philadelphia      Ex-  
perimenting upon your suggestions I have drawn the lightning  
from the heavens      Sig      Dalibard      12 W pd  
1200 SSS E

In the above example the tariff is put at one dollar per word. No punctuation is given, because the language expresses the points. Thus as preceding the sig. the receiving operator knows there is a full stop; the SSS is the finish signal. Sometimes the office signal is given at the end, and at other times the operator's initial is given.

The following example illustrates the sending of a message from Philadelphia to London, viz.:

#### EXAMPLE II.

P to L June 1 1752 for Mr Collinson London      By the  
aid of a kite I have demonstrated that lightning and electricity  
are identical      Sig      Benjamin Franklin      15 W  
pd 1500 Ahr A

Example 2 illustrates the affixing of the signals, indicating that another (Ahr) message is to follow. America, without receiving any response from Europe, proceeds at once to send another dispatch, and so on until there are no more. When

all are sent, the signals SSS are given, and in response Europe says I I O K E, which means that the whole are understood, and that all had been received correct.

The following example gives the last words of the late illustrious Emperor of Russia. The news was telegraphed from St. Petersburg to the Kremlin City.

## EXAMPLE III.

S to M March 5 1855 for the People of Moscow The  
Emperor bids farewell to Moscow Sig Nicholas  
6 W D H SSS S

The foregoing examples represent the mode of transmitting messages where no punctuation is given. When a message contains two or more independent subjects, or broken into paragraphs, it is represented by the proper signals. Other points of punctuation are seldom used on the American lines. In Europe more attention is given to them.

# TELEGRAPH ELECTRIC CIRCUITS.

## CHAPTER XXXV.

Electric Circuits on European Lines—Circuit of the Main Line described—Adjustment of the Line Batteries—Early Experimental Circuits—The Stager Compound Circuits—Combining of Electric Circuits.

### ELECTRIC CIRCUITS ON EUROPEAN TELEGRAPHS.

In the present chapter it is my purpose to explain the simple and compound electric circuits as applied to the working of the telegraph, with special reference to the Morse system. As a preliminary, it is important for the reader to be informed, that

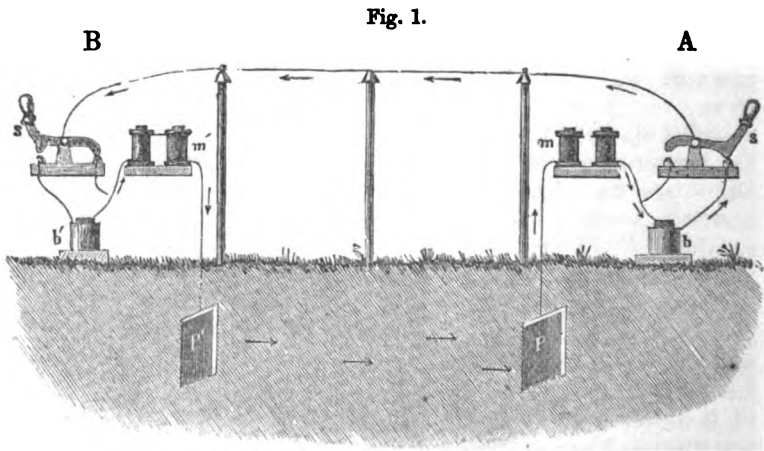

on the European lines the current of electricity is transmitted over the wires by the manipulating station. In its normal or rest state, the line wire is free from the voltaic current. The reverse of the above is the practice on the American lines. Their normal state is electrical. They are continuously charged

with the voltaic force, and the manipulation for the transmission of information breaks the flow of the current.

In further explanation of the above, I would refer the reader to fig. 1, which represents the European line, when being operated. The two stations are A and B, and the former is transmitting to the latter. In the normal state of the line, the key *s* at station A would be closed in the rear and open in front, exactly as represented by the key *s'* of station B. As the key is closed at A, the battery force of A charges the line. If the key of A was connected with the line, as the key of B, there would be no current on the line, because there would be no metallic circuit formed with the respective batteries. The base of the keys shown in the figure does not give a metallic circuit. The front is not metallically connected with the back part. The battery *b'* of station B is in its normal condition, that is, inactive. The course of the current generated by the battery *b*, of station A, follows the route indicated by the arrows, thus: through the anvil of the key, the key lever *s*, over the line wire to the lever *s'* of station B; thence from the rear of the key through the magnet *m'* to the earth plate *r'*; thence through the earth to the plate *p*; from the plate *p* the current ascends with the earth wire of station A, and traverses the magnet *m*, and thence to the zinc end of the battery *b*. Thus the circuit is made complete. If the lever *s* of station A is elevated from the contact shown in the figure, there will be no current on the line. The moment the battery is placed in the circuit, the current flows over the whole route. The station B is receiving, and in case the operator at B wishes to respond to A, or to interrupt the transmission, he presses the lever *s'* upon the anvil several times, and the effect upon the magnet *m* at A is at once seen, and the operator at A stops to ascertain the cause of the interruption. The operator at B then makes his explanations, during which process, the key lever *s* at A is elevated by a spring in front, so that the rear end is in contact with the metallic projection of the base; and the battery *b'* of station B is active, and the battery *b* of station A is inactive. The above explanations pertain wholly to the single or main circuit. The route of the current and the mode of interrupting it, by the opening and closing of the circuit, have been described. It is necessary, however, for the reader to remember, that the wires connecting the rear ends of the respective keys with the wires between the batteries and the magnets, are not used on the American lines; erase them from the figure, and the circuit will be composed as practically operated in America, excepting the key *s'* of station B should be closed as represented at station A. Hav-

Fig. 2.

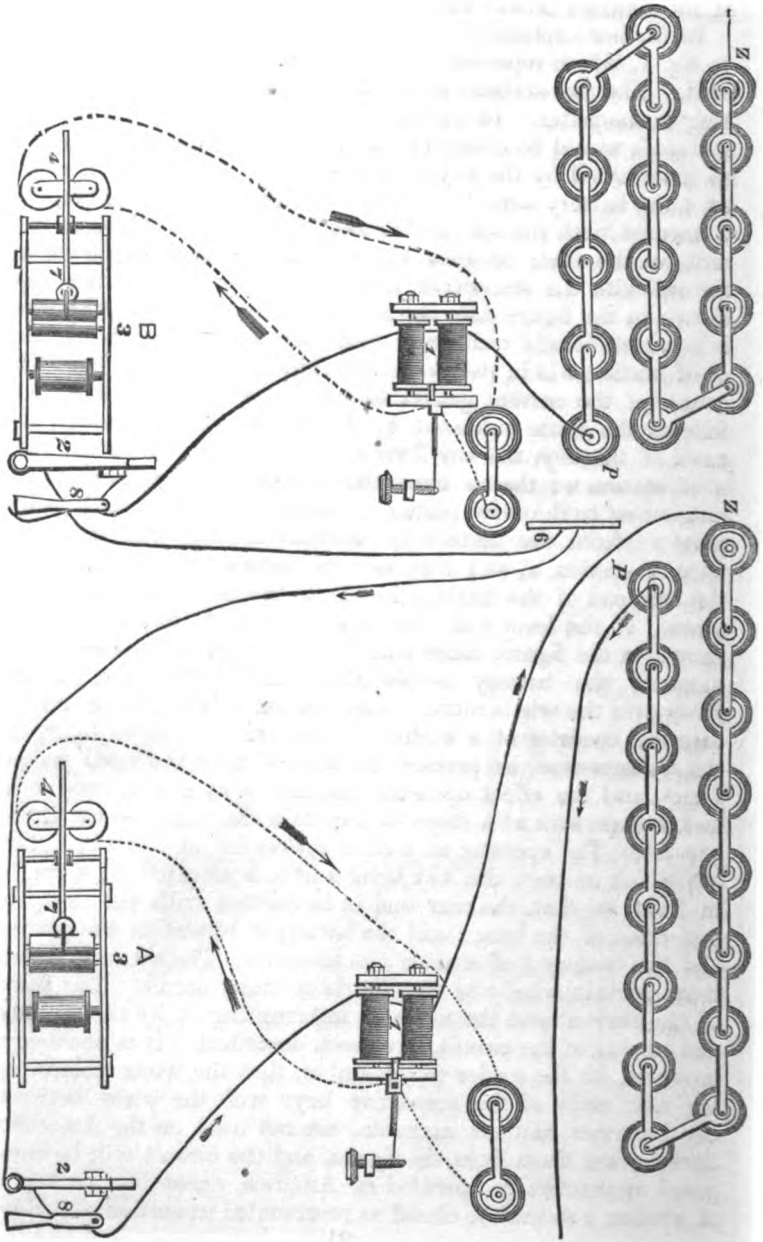

ing fully explained the main circuit, I will now proceed to describe its functions telegraphically applied.

THE CIRCUIT OF THE MAIN LINE DESCRIBED.

Figure 2 represents two stations, for example, New-York and Washington, distance 250 miles. The normal state of the line is shown, the current flowing continuously as indicated by the arrows. The right hand station *A*, is New-York, and the left hand, *B*, is Washington. The numerals at the two stations indicate the same parts at each respectively: 1, 1, are the electro or relay magnets; 2, 2, the base frames of the keys; 8, 8, are the key levers; 3, 3, are the register frames; 4, 4, the register or local magnets; 6, the line; and 7, 7, the pen lever; *p*, *p*, are the platina or positive poles of the batteries, and *z*, *z*, are the zinc or negative poles of the batteries. The zinc end of the battery at Washington is connected with the earth, and the platina end is joined to the line wire. At New-York, the platina end of the battery is joined to the earth wire. In figure 1, the battery is placed between the magnets and the keys; in figure 2, it is placed between the magnet and the earth. The proper place for the battery is as represented in fig. 2, that is, next to the earth.

In fig. 2, the current generated at Washington, follows the wire to and traverses the magnet 1, thence to the key 8 over the line 6, to New-York, thence into the office to the key 8, thence to and through the coils of the magnet 1, thence to the zinc pole of the battery, and after traversing the different cells it proceeds from the pole *p* to the earth. The reader will observe that the batteries are always constructed, so that the poles will be in the same direction. If the poles *p* and *p* were united, the battery would be ineffective. The special function of this circuit is to generate magnetism in the soft iron cores of the magnet 1 and 1. When the current flows through the coils, the iron cores become magnetized, and when it ceases to flow they are demagnetized. The passage of the voltaic current over the wire and through the spools or bobbins, instantaneously produces magnetism in the iron cores. When the line and the iron cores are thus charged, the armatures of the magnets are immediately attracted, which action closes other independent circuits. The dotted lines indicate the latter, or local circuits, which run from the armatures of the magnets 1, 1, to the batteries *L*, *L*; thence to and traverses the spools of the magnets 4, 4, of the registers, and thence to the armatures of the magnets. The opening and closing of these local currents attract or let go, the armatures 7, 7, of the

Fig. 3.

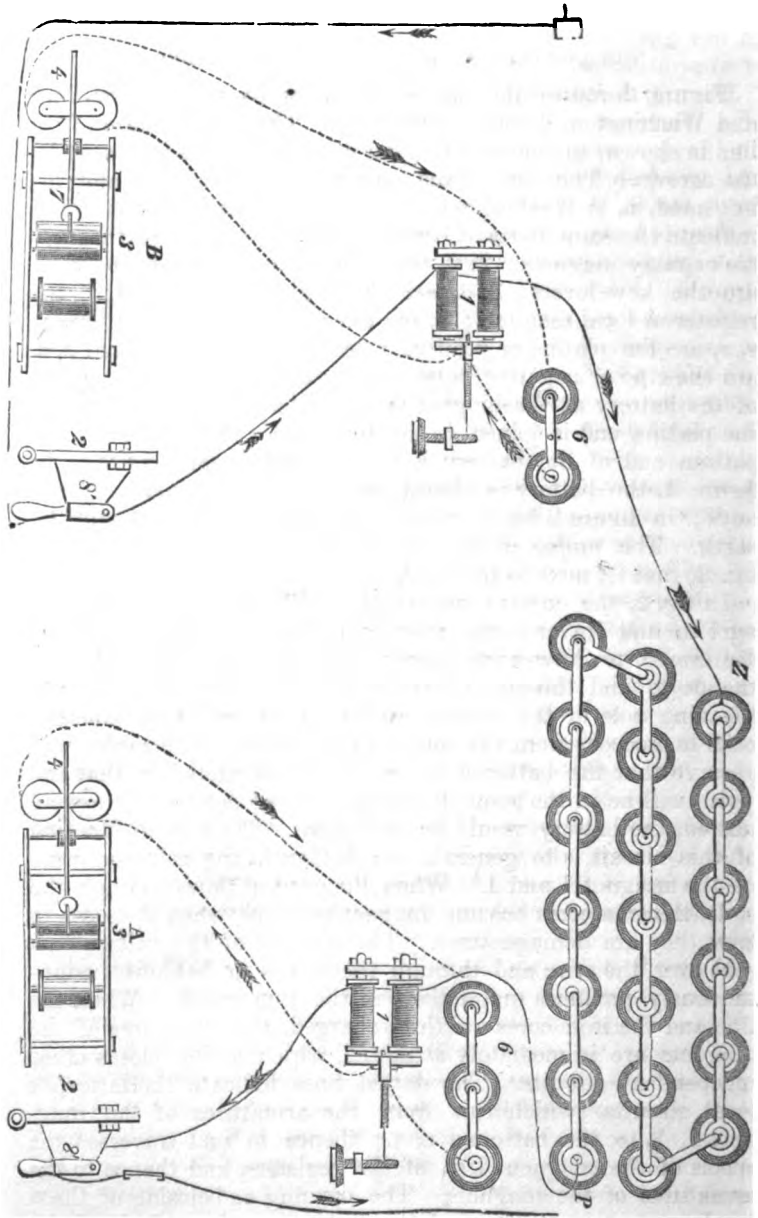

registers. The special and only function, therefore, of the main circuit is to open and close the local circuits in each office on the line, and the local circuit gives motion to the writing or imprinting pen levers, 7, 7, in each register.

Having described the arrangements of the two end stations of a telegraph line, I will now explain the organization of a line having on it one or more local stations. The terms *main* and *local* apply to the special arrangement of the batteries; for example, New-York, being the end of the line, the main battery is located at that station, Philadelphia, Baltimore, and other places, do not require batteries other than on their local circuits. Practically, however, the above places have main batteries for general application, on one or more of the many wires connecting those cities with others. The batteries at the two ends are fully sufficient to work the whole line, except under circumstances of bad insulation. The localization of the main batteries give those places the name of "main stations," and the use only of local batteries and the fact of their intermediate positions give to the other stations the name, "local stations." If an intermediate office has a main battery, it is called a "main station;" as, for example, the arrangement represented by fig. 3: A, is a "main station," and the other, B, is a "local station," the former, A, representing Philadelphia, and the latter, B, Baltimore. The Baltimore station, it will be observed, has no main battery, and the current from the Washington line wire enters the station, passes through the key, 2, 8, to the magnet coil 1, and thence to the main auxiliary battery at Philadelphia, where the current proceeds from the platina end of the battery through the magnet coils, thence to the key, and thence to New-York. The local batteries are marked 6, 6, one of which has two cells, and the other has three. It is usual to use but two; occasionally, however, when it is not sufficiently effective, owing to its decay, or from some other reason, the number is increased to three or more.

Figure 2 represents the two termini stations with their main and local batteries; and figure 3, two intermediate places, one a "local" and the other a "main" station.

A line of telegraph 300 miles long, can be successfully operated when properly insulated, in one circuit. In many cases, lines have worked a longer distance, but as a practical circuit on the American lines, 300 miles is a fair average. When the length of a line exceeds the power of the end batteries to charge it effectually with the voltaic current, it is the practice to place a main battery at an intermediate station, as





## ADJUSTMENT OF THE LINE BATTERIES.

As to the amount of battery necessary to charge a line of 300 miles there is no fixed rule. It is a question depending upon the climate, the quality and size of the wire, and the insulation of the line wire. Ordinarily, in good dry weather, a Grove battery of 60 cells will be sufficient to effect successful operation. If the weather is damp, or the insulation at fault, the circumstances of the case must determine the amount required. It very often occurs on the American lines, that the station at one end of the line can receive well, and the other end can not receive anything intelligible. For example, on line A B, 300 miles long, B cannot understand the faint signals received from A, but at the same time A receives perfectly from B. This diffi-

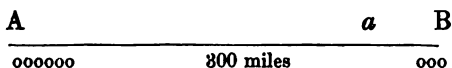

culty is occasioned, sometimes by atmospheric electricity, but more generally by faults of the line insulation. The metallic conductor is imperfect near B. The battery at B becomes active as a quantity battery. Its quantitative development is plus, and does not harmonize with the intensity stream coming from A. One of the remedies in such cases, is the reduction of the number of cells at B, and the increasing of the battery at A. I have sometimes found benefit in the polarization of the batteries to meet the emergency; thus, by placing the platina or positive pole of the battery at A, directed toward B, and the zinc pole to the earth. The battery at B should also be reversed. Some experts are of the opinion, that the direction of the poles have no particular value in the working of a line; in my experience, I have found the fact to be otherwise, and entitled to consideration.

If there be an earth connection at *a* near B, the quantitative development at B will be plus, and in practical service I have found that it had a retarding or hindering influence of the intensity current from A. The reduction, therefore, of the battery at B lessens that hinderance, and the current from A becomes more effective. The earth connection at *a* will carry off a part of the electric force from A, but if the conductor from *a* to the earth be insufficient to lead off the whole, enough will pass on to the station B, to effect the ends of telegraphing. Suppose that seventy-five per cent. is carried off to the earth at *a*, and the remaining twenty-five per cent. continues on to B, that, or even a less amount, will be sufficient. Station B, under such a state of the electrical force, can communicate with A. The

magnet at A can not be wholly demagnetized, but the strength of the magnet force will be minus and plus, according to the manipulation of B. The armature of A will have to be removed farther from the cores of the spools, so that the breaking of the circuit at B, will be effective in the attraction of the armature of the magnet at A. When the circuit at B is broken, the seventy-five per cent. current that passes off at a, creates in the soft iron cores at A, seventy-five per cent. of attractive force. The adjustable spring of the armature may draw it beyond that power, but the moment B closes the circuit, the magnetic force of the cores at A, becomes increased twenty-five per cent., and the spring no longer holds the armature, and it is attracted so that the armature-lever closes the local circuit, and thus the apparatus at A becomes subservient to the will of the operator at B.

The difficulties hereinbefore described are not always chargeable to the causes given. Sometimes the fault will be found in the connections of the wire, and many times I have found it to be with the earth wire. The earth must be moist where the connection with the telegraphic conductor is made. The metal surface in the earth should be large. In my experience, for an iron wire line, I have found it best to have an earth wire of copper, number 12, Birmingham gauge, well soldered to a copper plate, at least two feet square, or its equivalent surface, and buried in the wet earth. If the earth be not wet, the working of the whole line will be less effective. Dry earth is considered a non-conductor; therefore, in order to consummate a perfect circuit, it is necessary for the metallic surface, in contact with the water of the earth, to be commensurate with the conductivity of the line wire. If the earth connection be inferior, the electrical action of the battery will be minus in the same proportion. It is better to have the conductor uniform, equalling the generative powers of the battery, so that the voltaic streams can be sufficient for the consummation of the most certain and effective telegraphic manipulation.

#### EARLY EXPERIMENTAL CIRCUITS.

In July, 1747, Dr. Watson, Bishop of Llandaff, together with several other electricians, ascertained the passage of electricity through the water, by sending shocks across the Thames, and in August, 1747, they transmitted shocks through two miles of wire and two miles of earth at Shooter's Hill.

On the experimental line, erected by Professor Steinheil from Munich to Bogenhausen, in 1836, two lines of wire were

erected to complete the electric circuit. It was not then known that the earth would serve as one half of the conducting circuit. Soon thereafter, he discovered that the earth would answer, and that only one wire was sufficient for telegraphic purposes. When Morse constructed the experimental line from Baltimore to Washington, he did not know that the earth would answer for the half circuit, and therefore he erected two wires, and the voltaic current was sent over one wire and it returned over the other, as represented by fig. 4: *B* is Baltimore, and *W* is Washington. One of the wires is east and the other west. The

Fig. 4.

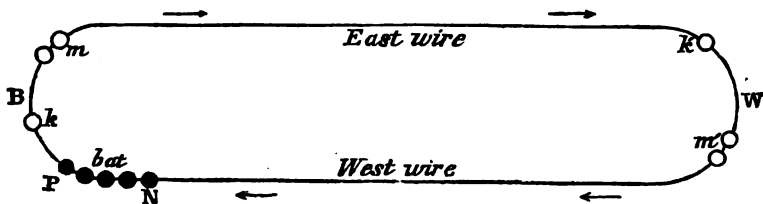

current starts from *P*, the positive pole of the battery, passes through the key, *k*, and the relay magnet *m*, at the Baltimore station, thence over the east wire to Washington, where it passes through the key *k'*, the relay magnet *m'*, and thence over the west wire to Baltimore, where it enters the negative pole of the voltaic battery.

After the line had been in operation for some six months, the earth was made a part of the circuit, according to the following diagram.

Fig. 5.

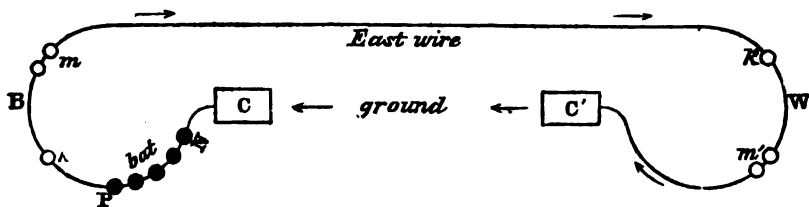

The route of the current is precisely the same as the diagram before described, except that the earth is made a part of the circuit. The current arriving at copper plate *c'* passes through the earth as indicated by the arrows, to copper plate *c*, which is also buried in the moist earth, and thence to the *N.* pole

of the battery. The plates used by Professor Morse were five feet long, and two and a half feet broad; at Baltimore, it was buried in the water at the bottom of the dock, near Pratt street; at Washington it was placed in the earth under the Capitol.

A subsequent experiment demonstrated the practicability of working the two wires, arranged as represented in the following diagram.

Fig. 6.

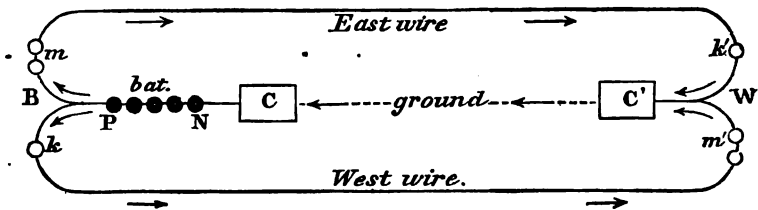

By this arrangement the keys were not required to be closed. Each station had its wire, independent of the other. At that time it was a discovery of great import, and to Mr. Alfred Vail the credit is due. They were called independent circuits. It will be seen that the west wire was used for transmitting from Baltimore to Washington, and the east wire from *w* to *b*. The battery at *b* was used in common for both circuits. When *b* transmitted to *w*, the current proceeded from *p* of the battery to *k*, then over the west wire, then to *m'* at *w*, thence to *c'*, thence through the earth to *c* at *b*, and thence to the *n*, or negative pole of the battery as shown by the arrows. When *w* transmitted to Baltimore, the current proceeded from the *p* of the battery to *m*, then over the east wire, then to *k'*, at *w*, thence to *c'*, thence through the earth to *c* at *b*, thence to the *n*, or negative pole of the battery, as shown by the arrows. In the above arrangement Mr. Vail used but one battery, and the same earth-plates common to both lines. The circuits were called "open circuits," because the keys at each station were always open, unless when used for transmitting intelligence.

In 1844, Mr. Vail experimented on the line between Baltimore and Washington, with the two telegraph wires then erected. There were none others in America. When he ascertained that the two wires could be practically worked, as described hereinbefore, he advanced the opinion, that several circuits could be operated with one battery, or by a series of batteries.

In the following fig. 7, let the right-hand side represent Washington, and the left Baltimore. The lines 1, 2, 3, 4,

5, and 6, between *m* and *k*, respectively, represent the six wires connecting (for example) Washington with Baltimore; *m* 1, *m* 3, and *m* 5, represent the three magnets, or registers, and *k* 2, *k* 4, and *k* 6, the three keys, or correspondents, at Baltimore; *k* 1, *k* 3, and *k* 5, are the three keys or correspondents, and *m* 2, *m* 4, and *m* 6, the three magnets or registers, at Washington.

Fig. 7.

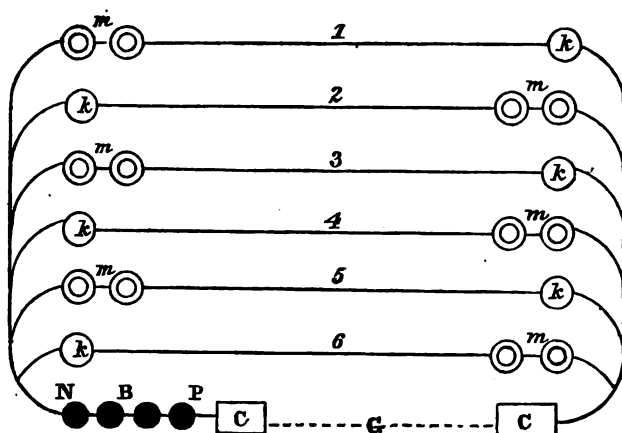

The battery is represented by four black dots, marked *n*, *b*, *p*. The course of the fluid in this case is from *p* to *c*, the copper plate on the left side; then through the ground to *c*, the copper plate on the right; then through the single wire to any of the six wires, which may be required, then to the single wire on the left side to *n*, of the battery. It is obvious that in this arrangement there is a division of the power of the battery, depending upon the number of circuits that may be closed at one instant. For example: if circuit 1 is alone being used, then it is worked with the whole force of the battery. If 1 and 2 are used at the same instant; each of them employ one half the force of the battery. If 1, 2, and 3, are used, then each use one third its power. If 1, 2, 3, and 4, then each circuit has one fourth the power; if 1, 2, 3, 4, and 5, are used at the same moment, then one fifth is only appropriated to each circuit, and if 1, 2, 3, 4, 5, and 6, then each employ a sixth part of the voltaic fluid generated by the battery.

## THE STAGER COMPOUND CIRCUITS.

On the extension of the lines, their continual use becoming necessary for commercial purposes, the working of the lines with open circuits, according to the plan adopted by Mr. Vail, was found impracticable for successful telegraphing.

The plan was then adopted, to keep the circuits always closed, and the battery current continuously on the line wires. This occasioned the necessity of placing upon each wire a battery, each independent of the other. It was maintained at a very great expense, but there seemed to be no law known by which it could be avoided.

For several years the lines throughout America thus worked. Various plans were tried to economize in the battery organization, but without success. The most skilled experts had their attention directed to the subject, and it fell to the lot of Mr. Anson Stager, of the Cincinnati station, to devise a plan by which might be successfully operated any number of lines from the same battery. This discovery made by Mr. Stager, in December, 1850, gave additional evidence of the very superior skill which had before and since characterized his telegraphic career. Mr. Stager thus explains his plan of operating a series of lines by the same battery.

Fig. 8.

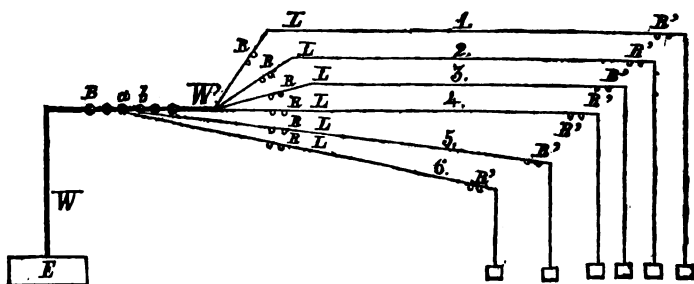

The improvement consists in working a "multiplicity of main circuits with a *single main battery*, instead of a battery to each circuit, as was practised previous to this discovery." It is described as follows :

B, is a main battery, w, w', large wires leading from the poles of the battery ; E, the earth-plate ; L, L, L, L, four main lines branching from the large wire of the battery at w', and extending to the several terminal stations, each finally connect-

ing with a ground plate. In their course each of the main lines may include at any point, or points, where stations are required, receiving magnets, represented by  $R, R', \&c.$ , connected in each instance with registers and the usual telegraphic apparatuses.

*Mode of Operation.*—The single battery,  $B$ , being in action, any one or all of the apparatuses in the several main circuits, may be used and operated in the same manner as though each main circuit was a separate and independent circuit, supplied with a separate and independent battery; and, herein consists the novelty and utility of the improvement, viz.: A multiplicity of circuits at even twenty or more, each extending several hundreds of miles, can thus be worked by means of a *single* battery, instead of one to each circuit, as was practised previous to this improvement. In this use of a single battery, according to the above described plan, there is no interference of circuits, one with another; each performing its functions, precisely as it would do if it were a complete and independent circuit. Nor does the single battery, thus used to supply many main lines, seem to be consumed faster than the single battery of a single circuit as formerly used.

In case one or more of the main circuits be short, for example, 5 and 6, they need but a small voltaic force, and they may be supplied by branches, starting out at intermediate points of the battery, as at  $a$  and  $b$ . The voltaic force, thus taken from a section of the battery, will not diminish perceptibly the current on the other main circuits.

It is a condition necessary to the success of this mode of working, that each main circuit include a receiving magnet, or a resisting wire equal to that of a relay magnet. There must be no "cut off," or earth conductor, between the main battery and a contiguous receiving magnet. If a circuit be thus made, the battery force will be withdrawn from the other circuits, and they may cease to operate effectively. If the earth connection be made beyond the receiving magnet, as at  $L$ , thus compelling the electricity to traverse the fine wire of magnet  $R$ , before reaching the earth, and returning to the prime ground plate  $E$ , there will be no interference with the other main circuits, though they may be of great lengths, and the other circuit very short. This affords to the operator the advantage of working one or more registers within the same station with the battery, independently of all other registers, and without any interference with them.

In the plan as heretofore practised, of having a battery in each circuit, the quantity of electricity generated, was more



than sufficient for supplying the single circuit; and the plus was retarded by the resisting coils of the magnets. It has been practically demonstrated, that when there are several main circuits connected with one main battery, *each with its receiving magnet or coils of resistance, prevents the electricity from taking one circuit exclusively*, and the voltaic force will be diffused over all the circuits sufficiently for telegraphic service. The surplus electricity which was on the single circuit system wasted or returned, by return shocks through the battery, is, by this improvement, brought into actual service.

Another valuable advantage resulting from this arrangement is, that an operator, having a key in the main common circuit between  $E$  and  $w$ , can work all of the registers on all the main circuits, and can thus multiply and diffuse identically duplicate copies of important documents, or newspaper reports, to all points at the same moment.

#### COMBINING ELECTRIC CIRCUITS.

As soon as the telegraph lines were extended over long ranges, it was found to be impracticable to operate them in long circuits. Various experiments were then made to remedy the difficulty. Mr. Ezra Cornell, arranged the apparatus of one station to open and close the next succeeding circuit. This

Fig. 9.

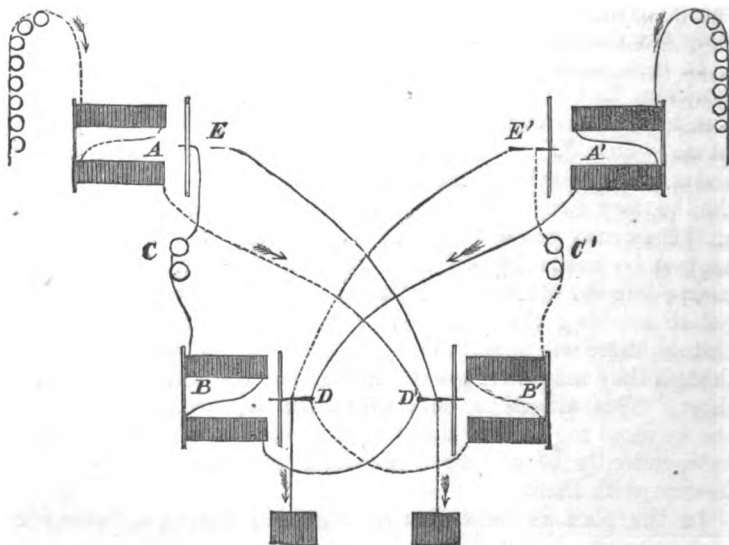

was called the "Cornell switch." By this arrangement, the second circuit could not respond without a transfer of the switch instrument at the central station, done by the operator. When B answered A, the operator at the central station, with a spring, changed the register magnets, or the local circuit, from the relay magnets of the circuit of A, to the circuit of B.

The next arrangement operated, was one proposed by Col. John J. Speed, Jr., and is represented by fig. 8. The instruments in the figure are supposed to be at Cleveland. On the right, the wires run to Detroit, and on the left, to Buffalo. A A' are relay magnets, constructed with a platina point to close the connecting circuit, through the action of a spring, when the main circuit is broken; B B' are the connector magnets; C C' are local batteries, to operate the connector magnets; D D' are closing points, to each of which is attached one main wire and one of the connectors; E E' are the closing points to which the connecting circuits are attached.

The manner of operating this instrument, commonly called a "repeater," is as follows, viz. :

When Buffalo breaks the circuit, the armature of the relay magnet A, at Cleveland, will be drawn back by means of the spring, against the closing point E. This will put in action the battery C, and the magnet B will break the connection at D, thus breaking the circuit of the Detroit line at D, and also breaking the connecting circuit, from the battery C' at the point D'. The breaking of the battery current C', prevents the magnet B' from breaking the Buffalo line at the point D'. When Buffalo closes the circuit, the relay magnet A, will break the connecting circuit, from the battery C, at E. The armature of the connector magnet B will be drawn back, by means of a spring, against the point D, and close the Detroit circuit at the point D, at which time the connecting circuit C', is also closed on the same point, and at the same instant. The main battery on the Detroit circuit having the greater number of cells, will break the connecting circuit C', at the point E' before the small battery C' will operate the magnet B, and break the Buffalo circuit at D'. The law being, that the battery of the greatest *intensity* will make its magnet first, or, in other words, the *velocity* of a current of electricity is in proportion to its *intensity*. This arrangement is now obsolete.

# ELECTRIC CURRENTS.

## CHAPTER XXXVI.

Electric Currents explained—Electric Circuits—Quantity and Intensity Currents—Phenomena of the Return Current—Retardation of the Current illustrated—Estimated Velocity of the Electric Current on Subaqueous Conductors.

### ELECTRIC CURRENTS EXPLAINED.

IN the consideration of electric currents I shall have especial reference to their application to purposes of practical telegraphing—of the science to the art. It is possible that some of the views entertained by me, and which are founded upon observations during several years of telegraphing, may not be consistent with theoretical laws advanced from time to time by philosophers. In my experience I have found many problems in electrical science unsolved, and which to this day remain hidden mysteries, known to Him alone who rules the storms and directs the movements of worlds.

A current of electricity is the passing of an invisible and an imponderable fluid over certain matter acting as conductor, starting from its generating source, traversing the circuit, and ending at the point of starting.

The source from which the current flows is known as the voltaic battery; one end of which is positive and the other end negative. It is composed of two metals and chemical compounds. The media through which the stream of electricity flows from one end of the battery to the other are called electric conductors, and they are usually of iron or copper metal. The whole chain of metals and chemicals through which the electric current or stream flows is called a circuit. A contact between the parts must be complete or there can be no electricity; because there can be no electricity if the two poles of the voltaic organization are not connected with one continuous and unbroken circuit.

The electric influence is sometimes called a "pulse," a "wave," a "stream," a "current," a "fluid," &c. These terms can mean but one thing, and that is, the presence of electricity.

## ELECTRIC CIRCUITS.

Overground wires, suspended on poles, extend in circuits of indefinite lengths, usually, as a maximum, three hundred miles. The electric circuit will be as a maximum six hundred miles; that is, three hundred miles of wire and three hundred miles of earth. The tendency of the current, when it leaves the positive pole of the battery, is to reach the negative pole as soon as it can. Static or frictional electricity will leap from one conductor to another to reach its opposite; but dynamic electricity, generated by a voltaic series, requires one continuous conductor in order to have life or existence.

In the use of the term or technicality, "dynamic," I mean electricity that has a continuous movement over the conductor, from one pole of the battery to the other, effecting an uninterrupted neutralization or a continual re-union of the two electricities—the negative and the positive.

If "dynamic electricity" is transmitted over very fine metal wire, and of short length, the metal becomes heated and may melt. If the conductor be water, when the "dynamic current" is transmitted, the water is in part decomposed, and its two constituent gases, the oxygen and hydrogen, are seen to be set free.

On a line of some three hundred miles it is certain that there will be many media through which the fluid can, in part, escape to the earth and return again to its original source. From each of these escaping places on the route, branch off lesser circuits; and in the three hundred miles there may be three hundred places where small portions of the current "leak" from the wire and pass off in small streams to the earth. If these conductors were equal to the wire the whole of the current would pass to the earth and return to its original source, and not traverse the line circuit. These media through which the current passes off from the line wire, are some of the many conductors mentioned elsewhere in this work, and to which may be added fog and heat. Fig. 1 represents a line passing through the air on poles. *A* is a sectional view of the wire; *B* is fog or heat, and *C* is the earth. The voltaic current is represented by the arrows. In working a telegraph line through a heavy fog, much difficulty is experienced, and it frequently becomes necessary to increase the number of the

Fig. 1.

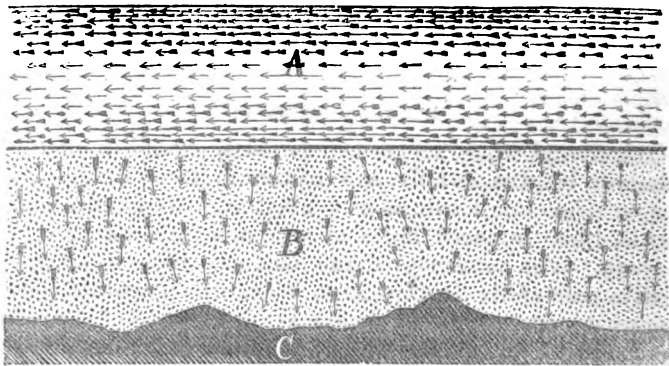

cells to obtain intensity of current sufficient to overcome the losses occasioned by the fog. The current escapes through the watery particles in contact and reaches the earth. The figure does not exactly represent the case, but it is sufficiently correct to enable the reader to form an idea as to the "leaking" of the current from the wire through the fog to the earth.

Heat has frequently produced the same result as mentioned above. On some lines in America, during very hot days, in the afternoon, when everything was dry and all surface moisture absorbed by the rays of the sun, I have known it to be impossible to work on a well-insulated line as far as two hundred miles. The result may not have been the heat, but there is no other way to account for it. The metallic circuit was good, because at times when it was dry and cool, or when it rained, and during the morning hours, there was no difficulty in work-

Fig. 2.

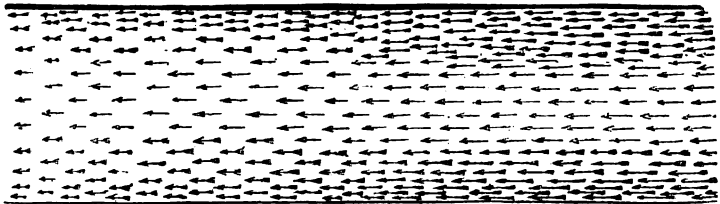

ing the line. The dry, hilly regions traversed by the line were free from trees, from grass, and from everything that partook of moisture. If it was not the heat, I know of no means of accounting for the strange phenomena which so often and for so many weeks manifested itself.

## QUANTITY AND INTENSITY CURRENTS.

I have frequently in this work used the terms *quantity* and *intensity* currents, and I have, on as many occasions as possible, explained the element of each. On a line of three hundred miles a quantity current would be of no value. Connect a line of that length to a large quantity battery, and the wire would be burned long before the intensity nature of the current would reach the farther end. It can be so great that it would partake of the nature of frictional electricity, and pass beyond the management of art. The telegraphic service requires a current of *intensity* and not of *quantity*. The strict technical definitions of these terms have been given by the great philosopher, Prof. Faraday, whose name stands in golden capitals upon many pages of the annals of progressive science. He says :

“The character of the phenomena described in this report induces me to refer to the terms *intensity* and *quantity* as applied to electricity; terms which I have had such frequent occasion to employ. These terms, or equivalents for them, cannot be dispensed with by those who study both the static and the dynamic relations of electricity. Every current, where there is resistance, has the static element and induction involved in it, while every case of insulation has more or less of the dynamic element and conduction; and we have seen that, with the same voltaic source, the same current in the same length of the same wire gives a different result as the intensity is made to vary with variations of the induction around the wire. The idea of intensity, or the power of overcoming resistance, is as necessary to that of electricity, either static or current, as the idea of pressure is to steam in a boiler, or to air passing through apertures or tubes, and we must have language competent to express these conditions and these ideas.”

The *quantity* of electricity developed by a given voltaic battery depends practically upon the size of the plates used. The *intensity* is the force with which the quantity is brought to bear upon anything to produce a given result; its *energy* in overcoming obstacles or impediments to the free passage of the electric current. This *intensity* is generally acquired by increasing the number of cells, and it is proportioned to that numerical increase. A *quantity current* can be so great as to be unmanageable for telegraphic service. It becomes as restless as static or lightning electricity, and will leave the wire in part, if near a better conductor. An *intensity current* is necessary for overcoming distance. In reference to this subject, that distinguished philosopher, Dr. Lardner, said, viz.:

“To produce the effects, whatever these may be, by which the telegraphic messages are expressed, it is necessary that the electric current shall have a certain *intensity*. Now, the *intensity of the current* transmitted by a given voltaic battery along a given line of wire will decrease, other things being the same, in the same proportion as the length of the wire increases. Thus, if the wire be continued for ten miles, the current will have twice the *intensity* which it would have if the wire had been extended to a distance of twenty miles.

*It is evident, therefore, that the wire may be continued to such a length that the current will no longer have sufficient intensity to produce at the station to which the despatch is transmitted those effects by which the language of the despatch is signified.*

The *intensity of the current* transmitted by a given voltaic battery upon a wire of given length will be increased in the same proportion as the area of the section of the wire is augmented. Thus, if the diameter of the wire be doubled, the area of its section being increased in a four-fold proportion, the *intensity of the current* transmitted along the wire will be increased in the same ratio.

In fine, the *intensity of the current* may also be augmented by increasing the number of pairs of generating plates or cylinders composing the voltaic battery.

Since it has been found most convenient generally to use iron as the material for the conducting wires, it is of no practical importance to take into account the influence which the quality of the metal may produce upon the *intensity of the current*. It may be useful, nevertheless, to state that, other things being the same, the *intensity of the current* will be in proportion to the conducting power of the metal of which the wire is formed, and that copper is the best conductor of the metals.

M. Pouillet found, by well-conducted experiments, that the current supplied by a voltaic battery of ten pairs of plates, transmitted upon a copper wire having a diameter of four one-thousandths of an inch, and a length of six tenths of a mile, was sufficiently intense for all the common telegraphic purposes. Now, if we suppose that the wire, instead of being four one-thousandths of an inch in diameter, has a diameter of a quarter of an inch, its diameter being greater in the ratio of sixty-two and one half to one, its section will be greater in the ratio of nearly four thousand to one, and it will, consequently, carry a current of equal intensity over a length of wire four thousand times greater—that is, over two thousand four hundred miles of wire.”

Fig. 2 is intended to represent the intensity current moving in a voltaic conductor. Commencing upon the right and running to the left, the farther from the place of starting the feebler becomes the force. The *intensity* or the energy of the current lessens in its force, as indicated by the lessening of the arrows in the given section of the conductor. In the preparation of the diagram, and the others in this chapter, I have waived the question as to localization of the motion and existence of electricity in the metallic conductor. It is my opinion, however, that the electricity on or near the surface might be properly called "electricity in motion," and that within "electricity at rest." I have no doubt but what the presence of electricity pervades the whole wire, but that the intensity, principally, has its motion at or near the surface. I am led to believe this from the result of some experiments which I have instituted. It is a question of much importance to the telegraphic enterprise, and it is to be hoped that others will give it a careful consideration.

In regard to the distribution of electricity on a circular plane, it has been found that the extent or thickness of the electric stratum was almost constant from the centre, to within a very small distance of the circumference, when it increased all on a sudden with great rapidity. The end section of a wire may represent the plane, and the philosophy established would prove that the inner or centre part was but slightly charged with electricity, and that it increased as to volume or amount from the centre to the surface; but that at or near the surface it was very considerably increased. My experiments have confirmed the truth of the foregoing law. It may be possible that the *intensity* of the current moves at or near the surface of the conductor, and that its quantitative element pervades the whole metal.

Fig. 3.

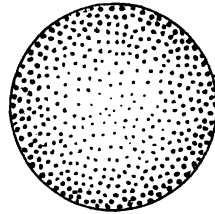

The foregoing remarks may be applied to all kinds of telegraph conductors, whether in air or in the earth.

#### PHENOMENA OF THE RETURN CURRENT.

I will, in the next place, notice the difference between practical working of subterranean, submarine and air lines.

On air lines we have to contend against atmospheric electricity, induced currents and cross currents, or the escape of the electricity by heat, fog, &c. On subterranean and submarine lines a new phenomenon has been manifested, which materially



interferes with the successful working of the telegraph. Whether in the earth or in the water, the philosophy is the same, except as the water exists in greater quantities nearer the submarine cable than to the subterranean, the influence is greater on the latter than on the former.

The discovery of this new phenomenon was announced by Professor Faraday in 1854; and notwithstanding electricians have expended much labor and money to discover a remedy for the difficulty, there has been nothing accomplished to ameliorate, in the slightest degree, the effects of the remarkable phenomenon in subaqueous telegraphing, described by Professor Faraday to the Royal Institute of Great Britain. The substance of the report will be found in the following extracts, viz.:

“In consequence of the perfection of the workmanship, a Leyden arrangement is produced upon a large scale; the copper wire becomes charged statically with that electricity which the pole of the battery connected with it can supply; it acts by induction through the gutta-percha (without which induction it could not itself become charged, Exp. Res. 1177), producing the opposite state on the surface of the water touching the gutta-percha, which forms the outer coating of this curious arrangement. The gutta-percha, across which the induction occurs, is only 0.1 of an inch thick, and the extent of the coating is enormous. The surface of the copper wire is nearly eight thousand three hundred square feet, and the surface of the outer coating of water is four times that amount, or thirty-three thousand square feet. Hence the striking character of the results. The intensity of the static charge acquired is only equal to the intensity at the pole of the battery whence it is derived; but its quantity is enormous, because of the immense extent of the Leyden arrangement; and hence, when the wire is separated from the battery and the charge employed, it has all the powers of a considerable voltaic current, and gives results which the best ordinary electric machines and Leyden arrangements cannot as yet approach.

Mr. Clarke arranged a Bain's printing telegraph, with three pens, so that it gave beautiful illustrations and records of facts like those stated; the pens are iron wires, under which a band of paper, imbued with ferro-prussiate of potassa, passes at a regular rate by clock-work; and thus regular lines of prussian blue are produced whenever a current is transmitted, and the time of the current is recorded. In the case to be described the three lines were side by side, and about 0.1 of an inch apart. The pen *m* belonged to a circuit of only a few feet of wire, and a separate battery; it told whenever the contact key was

put down by the finger; the pen *n* was at the earth end of the long air wire, and the pen *o* at the earth end of the long subterranean wire; and, by arrangement, the key could be made to throw the electricity of the chief battery into either of these wires simultaneously with the passage of the short circuit current through pen *m*. When pens *m* and *n* were in action, the *m* record was a regular line of equal thickness, showing by its length the actual time during which the electricity flowed into the wires; and the *n* record was an equally regular line, parallel to and of equal length with the former, but the least degree behind it; thus indicating that the long air wire conveyed

Fig. 4.

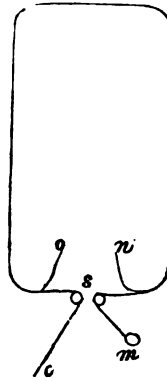

its electric current almost instantaneously to the further end. But when pens *m* and *o* were in action, the *o* line did not begin until some time after the *m* line, and it continued after the *m* line had ceased—*i. e.*, after the *o* battery was cut off. Furthermore, it was faint at first, grew up to a maximum of intensity, continued at that as long as battery contact was continued, and then gradually diminished to nothing. Thus the record *o* showed that the wave of power took time in the water wire to reach the further extremity; by its first faintness, it showed that power was consumed in the exertion of lateral static induction along the wire; by the attainment of a maximum and the after equality, it showed when this induction had become proportionate to the intensity of the battery current; by its beginning to diminish, it showed when the battery current was cut off; and its prolongation and gradual diminution, showed the time of the outflow of the static electricity laid up in the wire, and the consequent regular falling of the induction which had been as regularly raised.

When an air wire of equal extent is experimented with, in like manner, no such effects as these are perceived; or if, guided by principle, the arrangements are such as to be searching, they are perceived only in a very slight degree, and disappear in comparison with the former gross results."

#### MR. BRIGHT'S EXPERIMENTS ON THE VELOCITY OF THE CURRENT.

In reference to this subject, Mr. Edward B. Bright, the very able secretary of the English and Irish Telegraph Company, in association with the late Atlantic telegraph, has written a very clear paper, *viz.* :

"On extending this system [underground lines] throughout

the United Kingdom, where circuits of several hundred miles were brought into operation, it was found upon communicating a current to such wires, that, after the withdrawal of the excitation (whether galvanic or magnetic electricity was employed), an electric recoil immediately took place at the end of the wire to which the current had been previously communicated. This recoil was apparently analogous in all respects to the discharge of electricity from a Leyden jar, except that the current flowing from the wire partook of a quantitative rather than an intense nature; thus, however, finishing the remaining link of comparison, and establishing the identity as regards primary characteristics of all species of electricity.

Although this phenomena, as analyzed by Dr. Faraday, has proved highly gratifying in a philosophical point of view, its existence interfered materially with the working of all the previous existing telegraphic apparatus, not having been at all contemplated or provided for; and, up to this time, I am not aware that, as regards the galvanic system, any adequate remedy has been applied. The nature of the interference will be easily understood, when I mention that, with a letter printing telegraph, the surplus current has the tendency to carry the machinery on further, and to make other letters than those intended. *With the chemical and other recording telegraphs, the surplus flow of electricity will continue nearly a minute, entirely confounding the marks representing one letter with the next.* And, lastly, with Cooke and Wheatstone's and other needle telegraphs, a beat more is made by the back current than intended with every letter formed.

Another remarkable feature to be noticed in connection with the underground system is the small comparative velocity with which the electric impulse is communicated through each conductor in long circuits.

In experiments conducted by my brother and myself upon a circuit of four hundred and eighty miles of the underground wires, a *marked* difference between the communication of the electric impulse, and its arrival at the other end, has been observed; *the interval required for the passage of the sensation amounting to rather more than a third part of a second.*

The rate of transmission of the voltaic or magnetic fluids, through such conductors, is therefore only about one thousand miles per second.

Professor Wheatstone's experiments, showing the passage of *frictional electricity* through a short length of wire in a room, to take place at a speed approaching three hundred thousand miles per second, are well known and incontestable.

A subsequent experiment, conducted by Professor Walker, on some of the overground wires comprised in the American system, gives the velocity of the voltaic current, through two-hundred-and-fifty mile circuits, at about sixteen thousand miles per second.

The underground wires, however; as just mentioned, give a far lower result; and hence it appears evident that the velocity of frictional electricity far exceeds the voltaic or magnetic current, owing, doubtless, to the far greater intensity and comparatively small quantitative development of the former.

The retardation experienced in underground wires, as regards the propagation of the electric impulse, is not, however, due to any resistance of the conducting medium; for, as it is found, in the instance of the Leyden jar, that the frictional electricity communicated is temporarily absorbed by the metal in the interior of the jar, so the galvanic or magnetic currents, during their passage through the underground wires, are partly absorbed, until the mass of copper constituting the wire is saturated with electricity; and it would also appear that a definite time is occupied in the absorption of the electricity by the successive portions of the wire, such as is found to occur in charging a Leyden jar; and until this process of impregnation has been completed, the sensation cannot be communicated to the other end of the conductor.

The retardation will, therefore, result, not from resistance, but from the first portion of the charge communicated being absorbed for the time by the conductor through which it passes; for, in addition to the foregoing, copper wire conducts far more freely than the iron wire made use of in the overground wires.

Consequently the speed with which an electric impulse is communicated varies with the energy or intensity of the current employed, and the nature or conditions of the conductor interposed."

In relation to this subject, the following question among others, was propounded to Mr. Charles T. Bright, the engineer of the late Atlantic Telegraph Company, and his answer to the same is herewith given, viz.:

"43. What do you consider return currents? and to what extent do you find the existence of the same on both overground and underground lines? Please state all the points fully.

*Answer 43d.* On overground lines they are very trifling, indeed, compared with underground; the conditions on which the wires are suspended and insulated, passing also through a medium, capable, to a certain extent, of absorbing any electricity developed in surplus, prevents the occurrence of any effects appreciable by ordinary needle telegraphic instruments.

I look upon an underground wire as being exactly similar, on a large scale, to a Leyden jar, and I am borne out in this by the experiments of my brother and myself, and by those instituted by Faraday on the underground wires more recently laid by the Electric Telegraph Company. The magneto-electricity, as well as the voltaic (or chemical) electricity, evinces these phenomena, hitherto supposed to belong to properties appertaining peculiarly to frictional electricity.

The copper may be compared to the inner metallic coatings of a Leyden battery, the gutta-percha to the glass, and the earth and moisture surrounding to the outer covering.

I was much interested, in one of our experiments, to observe that the larger the size of the wire experimented upon, with the same battery power, the greater the amount of return current: a strong support of our opinion, as, had it arisen from an *elastic* return, owing to the wire being unable to receive as much electricity as was forced into it, as some supposed, of course a *smaller* wire (with the same power as that employed with the larger size) should have given out a *greater* amount of return current. If you experimentalize on No. 18 and No. 16, you will see this very clearly."

#### RETARDATION OF THE CURRENT ILLUSTRATED.

Fig. 5.

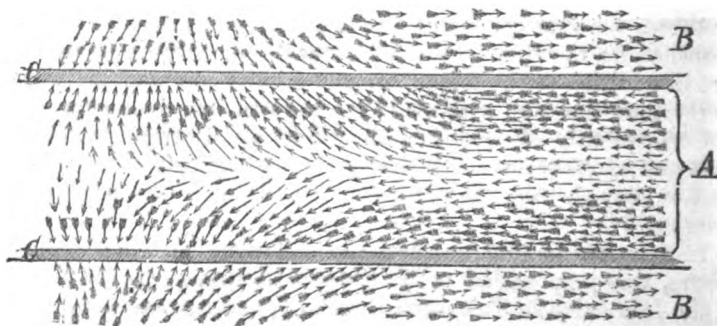

Fig. 5 represents a sectional view of a sub-marine cable: A is the copper conducting wire; C C the gutta-percha covering, serving as an insulation; B B is the water. The arrows represent the voltaic currents starting from A, full of energy. It presses forward in the completion of its circuit until overcome by the influence of the negative electricity of the earth. The wire is, in principle, the same as the inner coating of a Leyden jar, fully charged.

In charging the inner coating, nature furnishes simultaneously an opposite electricity on the exterior covering of the jar. The glass intervenes in the use of the jar, and the gutta-percha intervenes in the case of sub-marine cables. At the end c c, the positive current is seen at rest, brought to the position by the influence of the electricity of the earth, existing in the water. This phenomenon is called the retardation of the current. If at a a negative current be applied, the positive in the cable becomes neutralized. If the battery be disengaged from the cable, and the end of the wire be allowed to hang in the air for an hour, the electricity will be held in the cable in sufficient quantity to discharge a cannon, on renewing the earth circuit. The current thus coming back is called the "return current." The electricity of the earth encircling the cable is negative, when it is charged with a positive current. If the current transmitted through the cable was negative, then the earth electricity would be positive, and the effect would be the same. These imponderable elements seem to exist only in the effort to unite one with the other.

It is this retardation of the electric current that renders the success of ocean telegraphy so exceedingly questionable.

I have, time and again, expressed a want of faith in the practicability of operating long subaqueous conductors for telegraphic purposes, at least, until some new developments in science dispels the difficulties hereinbefore mentioned. The working of the subterranean telegraph lines in England, Denmark, Prussia, Russia, and other states of Europe, and of the various submarine lines, in different parts of the world, prove that long circuits through the water, or through the earth, can not be successfully operated, and that the maximum circuit that can be practically operated for telegraphic purposes, must be less than one thousand miles.

#### ESTIMATED VELOCITY OF THE CURRENT.

The operating of the line from Sardinia through the Mediterranean Sea to Malta, and thence to Corfu, demonstrates the impracticability of working long submarine telegraphs. The time required for the transmission of the electric current is irregular and unreliable. Such are the facts as known at the present time. The nearest estimate as to the time required for the transmission of the electric current, can be reliably based upon some experiments instituted by the brothers Bright, of England. The following was communicated to me by Mr. Bright:

"Answer 44th. In the course of a long series of experiments carried on last year, by my brother and myself, inquiries were

instituted with reference to the speed with which the galvanic or magnetic sensation is communicated through underground wires.

The result of the inquiry shows decidedly that the communication of the electric impulse through a length of 500 miles of underground gutta-percha covered copper wire (1.6 gauge) does not exceed 900 to 1,000 miles per second—a speed far below that usually assigned.

Reasoning upon the issue of these experiments, and those previously tried in America, I have no doubt that the speed of any description of electricity varies greatly with the peculiar conditions and nature of the conductor used, and also with the length of the conductor interposed; and that a wire suspended in the open air, especially if insulated only at points of its support, (such as in a pole line) would offer far less resistance (*cæteris paribus*) than a wire underground.

Submarine cables are similar, as regards electrical conditions, to subterranean lines, and the speed with which the electric impulse is communicated would be the same."

On the laying of the Atlantic cable in 1857, Professor Morse communicated the following important fact, viz.: "We got an electric current through until the moment of parting [of the cable], so that the electric connection was perfect; and yet *the further we paid out, the feebler was the current.*"

The highest speed of receiving intelligible and unintelligible signals over the late Atlantic cable, was about one wave, or pulsation, for each  $3\frac{1}{2}$  seconds. The value of the wave depends upon their combination in the formation of the alphabet.

#### WORKING OF THE MEDITERRANEAN TELEGRAPHS.

So true is the philosophy set forth in the preceding, that no practical telegrapher can question it; but, on the contrary, every experiment instituted on submarine or subterranean telegraph lines, adds evidence to its confirmation. Besides the proofs given, reference may be made to the following concise report of Signor Bonelli, the able director general of Sardinian telegraphs, viz.:

"Among the delays observed in the transmission of dispatches which cross Sardinia, I was at first surprised at the long intervals that were noticed between time when the dispatches were presented at Malta, and their reception at the Cagliari station—principally when these dispatches were of considerable length. Unwilling to suspect habitual negligence on the part of the employés at the Cagliari junction, I inquired as to the causes of the delay. I was told that the difficulty was in the method used

in this line, in consequence of the well-known inconveniences of submarine cables, which are the greater here, as the lines from Cagliari to Malta, and from Malta to Corfu, are each nearly 600 kilometres (about 375 miles), much longer than any previously existing. I, therefore, deem it useful to exhibit, in some detail, the effects which have been observed, the consequences which result therefrom for the service, and the importance of discovering a remedy.

The submarine cable between Cagliari and Malta is composed of a very fine copper wire, around which are twisted six similar wires of equal fineness, all in free contact with one another, so that if one or more of them should break, the transmission would not be interrupted. The seven wires together form a cord of about two millimetres (1-16 inch) in diameter, covered with a gutta-percha case of two millimetres, and a second envelope of tarred hemp. Eighteen iron wires, two millimetres in diameter, twisted in an extended spiral, enclose the whole, and form the outer covering of the cable, the total diameter of which is thus carried to 14 millimetres (about  $\frac{1}{2}$  inch), and weight 547 kilogrammes per kilometre (about 2,000 pounds per mile). The two extremities of the cable, both at Malta and Cagliari, are fastened to two pieces of wire on the land, each 5 kilometres (about 3 miles) long.

After the experiments made in England, and elsewhere, to diminish the difficulties which were foreseen, it was decided to employ for transmission induced electrical currents, with piles of a large surface, and a special apparatus to change the direction of the current alternately.

In spite of all these precautions, the following effects have been experienced :

If the transmission is made too rapidly, the signals are so uncertain as to become unintelligible ; it is better, therefore, to be very slow in making them. But several inconveniences result from this. Such a degree of special skill is required in the operator, that among the employés at Malta, for instance, only one was able to transmit the signals satisfactorily. Pauses of nearly a second must be made, so that scarcely 75 signals can be transmitted in a minute—that is to say, but two or three words—while on the land lines the average transmission in the same time is 280 signals, or perhaps ten words.

Besides—principally to avoid the difficulty of a current generated in the opposite direction, called return current—the apparatus is so arranged, that during the transmission from one side, nothing can be received from the other, nor can the current be interrupted. The operator to whom the message is



transmitted, cannot, therefore, give notice if a word has escaped him ; hence the necessity of suspending the transmission about every ten words, and reversing the apparatus, to ascertain if everything is understood, and if the words must be repeated before going further. This is one cause of an immense loss of time. And if the operator is not able to calculate the interval of the pauses precisely, the confusion of the signals makes frequent repetitions necessary, which almost indefinitely prolongs the duration of a dispatch. Finally, it is impossible to obtain simple points from the instrument, for, in working rapidly, we either get no signal at all, or a line ; hence, Morse's alphabet, instead of giving points and lines, is reduced to merely long and short lines. This is enough to show the danger of confusion and mistake.

To give an idea of the delay thus produced, it is only necessary to cite an example : A dispatch, consisting of 58 words, and containing news from India, took more than five hours in passing from Malta to Cagliari.

The causes of this have already been explained by Mr. Faraday, and proceed from the conditions of every cable, which performs the function of a Leyden jar ; the copper wire forming the internal armor, the gutta-percha and hemp make the insulation, the iron wire and water serving as the external armor, in communication with the earth. The extreme length of the cable gives it an immense surface, in spite of the fineness of the copper wire, and the interruption of the electric equilibrium which takes place on every passage, or on every discontinuance of the current by the reciprocal influence of the two armors and the insulating substances, occasions the delays as well as the apparent anomalies of which I have spoken in the action of the current on the telegraphic apparatus.

Another phenomenon quite important to notice—for it may perhaps suggest the remedy for the defects inherent in submarine cables—is that the confusion of the signals and the transformation of the points into lines were incomparably more numerous, when the telegraphic apparatus was attached directly to the end of the cable, than since the operation has been performed at stations with the interposition of five kilometres of wire on the land.

If the effects, of which I have stated the simple history, considerably obstruct the service of the Malta and Corfu lines, they also show how far the fears are justified with regard to the mischief they may produce on the far longer Atlantic cable, and the necessity of profiting by the lines already existing for the application of science to the correction of the difficulties.

It is true that Faraday and Whitehouse have made experiments touching the phenomena in question, but these experiments have been made only on cables prepared for immersion and coiled up in storehouses, or on submarine cables by uniting different wires, in order to multiply the length, or by combining them with long extensions of land lines. Now, in each of these cases, the effect took place of an inverse current on the cables or adjacent wires, whence resulted phenomena in the transmission entirely different from those which are manifested with a single current over a single wire of great length. Besides, if we have seen the great effect of the simple connection of five kilometres of land wire on a submarine cable of 600 kilometres, how can we estimate the influence of the land wires of so much greater length employed by the English experiments?

It seems to me that their reasons alone are sufficient to throw great doubt on the certainty of the result obtained by those experiments; but the convincing proof of their insufficiency is derived from a comparison of these results with those presented by the Malta line, although in both cases, the apparatus was the same and similarly arranged. While, in fact, we see an operator of the first order obtain a maximum of 75 signals in a minute, between Cagliari and Malta, on 600 kilometres, in the English experiments of October, 1854, from 210 to 270 signals in a minute (that is 6 or 8 words) were obtained, with currents on a circuit of more than 3,000 kilometres, over the subterranean and submarine wires between London, Dumfries, and Dublin. The rapid increase of difficulties from the Cagliari and Bona line, which is only 260 kilometres, to that of Cagliari and Malta, which is 600, leads to the conclusion that the same difficulties must be much more considerable on a line of 3,000. The reflections which naturally arise from the examination of the facts in the case, show to how great a degree it is necessary to study profoundly these questions of vital importance to the utility of great submarine lines.

BONELLI."

The following table contains the proximate velocity of an electric current on subaqueous conductors, based upon reliable experiments, instituted on submarine and subterranean telegraphs.

## VELOCITY OF THE ELECTRIC CURRENT ON SUBAQUEOUS CONDUCTORS.

No. 16, copper wire. Calculations based upon five pulsations per letter and seven letters per word.

| Miles.    | Time of Pulsation. |                     | Time per letter. |                     | Time per word. |                     |
|-----------|--------------------|---------------------|------------------|---------------------|----------------|---------------------|
|           | Min.               | Sec.                | Min.             | Sec.                | Min.           | Sec.                |
| 500.....  | 00                 | 0 $\frac{33}{100}$  | 00               | 1 $\frac{66}{100}$  | 00             | 11 $\frac{62}{100}$ |
| 1000..... | 00                 | 1                   | 00               | 5                   | 00             | 35                  |
| 1100..... | 00                 | 1 $\frac{24}{100}$  | 00               | 6 $\frac{20}{100}$  | 00             | 43 $\frac{40}{100}$ |
| 1200..... | 00                 | 1 $\frac{43}{100}$  | 00               | 7 $\frac{75}{100}$  | 00             | 54 $\frac{25}{100}$ |
| 1300..... | 00                 | 1 $\frac{93}{100}$  | 00               | 9 $\frac{65}{100}$  | 1              | 07 $\frac{55}{100}$ |
| 1400..... | 00                 | 2 $\frac{42}{100}$  | 00               | 12 $\frac{05}{100}$ | 1              | 24 $\frac{35}{100}$ |
| 1500..... | 00                 | 3                   | 00               | 15                  | 1              | 45                  |
| 1600..... | 00                 | 3 $\frac{73}{100}$  | 00               | 18 $\frac{65}{100}$ | 2              | 10 $\frac{55}{100}$ |
| 1700..... | 00                 | 4 $\frac{65}{100}$  | 00               | 23 $\frac{25}{100}$ | 2              | 42 $\frac{75}{100}$ |
| 1800..... | 00                 | 5 $\frac{79}{100}$  | 00               | 28 $\frac{95}{100}$ | 3              | 22 $\frac{65}{100}$ |
| 1900..... | 00                 | 7 $\frac{22}{100}$  | 00               | 36 $\frac{10}{100}$ | 4              | 12 $\frac{70}{100}$ |
| 2000..... | 00                 | 9                   | 00               | 45                  | 5              | 15                  |
| 2100..... | 00                 | 11 $\frac{21}{100}$ | 00               | 56 $\frac{05}{100}$ | 6              | 52 $\frac{35}{100}$ |
| 2200..... | 00                 | 13 $\frac{97}{100}$ | 1                | 09 $\frac{85}{100}$ | 8              | 08 $\frac{95}{100}$ |
| 2300..... | 00                 | 17 $\frac{40}{100}$ | 1                | 27                  | 10             | 09                  |
| 2400..... | 00                 | 21 $\frac{70}{100}$ | 1                | 48 $\frac{50}{100}$ | 12             | 39 $\frac{50}{100}$ |
| 2500..... | 00                 | 27                  | 2                | 15                  | 15             | 45                  |

# ELECTRIC TELEGRAPH CONDUCTORS.

## CHAPTER XXXVII.

Composition of Telegraph Circuits—Conductibility of Metals and Fluids—Conducting Power of different sizes of Copper Wire—Conducting Powers of Telegraph Wires—Advantages of Zinc-Coated Wires—Conductors composing a Voltaic Circuit—Strength of Telegraph Wires—Scale and Weight of Telegraph Wire.

### COMPOSITION OF TELEGRAPH CIRCUITS.

In the present chapter will be considered electric telegraph conductors. There are but two questions necessary to be discussed; first, the conductibility of the metals and other materials composing the voltaic circuits; and, second, the strength and durability of the metallic substances employed as component parts of the circuit.

A telegraphic circuit is composed of iron wire, copper wire, mercury, brass, tin, platina, zinc, acidulated water, and nitric acid. This arrangement contemplates the use of the Grove battery. The Smee, Daniell, Bunson, and other batteries, are sufficiently near the same organization, as to conducting elements, to be considered as equivalents. In regard to the conductibility of metals there seems to be some difference of opinion. Different experiments have produced different results.

### CONDUCTIBILITY OF METALS AND FLUIDS.

Some experiments instituted by M. Becquerel produced the results indicated in the following table. The conductibility of each metal is given respectively.

|                  |      |                    |      |
|------------------|------|--------------------|------|
| Copper wire..... | 100  | Platinum wire..... | 16.4 |
| Gold “.....      | 93.6 | Iron “.....        | 15.5 |
| Silver “.....    | 73.6 | Lead “.....        | 8.8  |
| Zinc “.....      | 28.5 |                    |      |

The following is the result of some experiments mentioned in the German works.

|              |     |               |     |
|--------------|-----|---------------|-----|
| Silver ..... | 136 | Platinum..... | 22  |
| Gold .....   | 113 | Iron .....    | 17  |
| Copper.....  | 103 | Mercury.....  | 2.6 |
| Zinc .....   | 28  |               |     |

This table is to be understood thus : a copper wire 100 feet in length, offers as great a resistance in the transmission of an electric current, as silver wire, of equal thickness, 136 feet long ; of gold 113 feet long ; of iron 17 feet long, and so on with the other metals.

Mr. Moses G. Farmer, of Boston, instituted thorough experiments, and the following were found to be the relative conductivity of the respective metals and fluids. The specific resistance to the transmission of electric currents, compared with chemically pure copper at ordinary temperatures, was, of

|                     |       |                         |       |
|---------------------|-------|-------------------------|-------|
| Copper wire.....    | 1.00  | Tin wire .....          | 6.80  |
| Silver " .....      | .98   | Zinc " .....            | 3.70  |
| Gold " .....        | 1.13  | Brass " .....           | 3.88  |
| Iron " .....        | 5.63  | German Silver wire..... | 11.30 |
| Lead " .....        | 10.76 | Nickel " .....          | 7.70  |
| Mercury.....        | 50.00 | Cadmium " .....         | 2.61  |
| Palladium wire..... | 5.50  | Aluminum " .....        | 1.75  |
| Platinum " .....    | 6.78  |                         |       |

His experiments with fluids produced the following results :

|                                                |               |
|------------------------------------------------|---------------|
| Pure rain water.....                           | 40,853,723.00 |
| Water twelve parts and Sulphuric Acid one..... | 1,305,467.00  |
| Sulphate Copper one pound per gallon.....      | 18,450,000.00 |
| Saturated Solution of Common Salt.....         | 3,173,000.00  |
| Saturated Solution of Sulphate of Zinc.....    | 17,330,000.00 |
| Nitric Acid 80° B.....                         | 1,606,000.00  |

#### CONDUCTING POWER OF DIFFERENT SIZES OF COPPER WIRE.

*Experiments showing the relative resistance of Nos. 18 and 16 copper wire, insulated by double covering of gutta-percha, and submerged in the Regent's Canal, London.*

No 18 gauge copper wire, covered with gutta-percha to gauge No. 7.

No. 16 gauge copper wire, covered with gutta-percha to gauge No. 4.

An ordinary single needle instrument was employed—connected to earth, as usual in practice.

|                             |         |                          |
|-----------------------------|---------|--------------------------|
| 100 miles.                  | No. 18. | No. 16.                  |
| With 3 pairs of plates..... | 29°     | 39° deflection of needle |
| " 6 " .....                 | 50°     | 59° " "                  |

The same instrument employed, but the needle slightly weighted :

|                             |         |         |
|-----------------------------|---------|---------|
| Battery of 72 pairs plates. | No. 18. | No. 16. |
| 100 miles.....              | 23°     | 30°     |
| 90 " .....                  | 25°     |         |
| 80 " .....                  | 26½°    |         |
| 70 " .....                  | 28½°    |         |
| 65 " .....                  | 30°     |         |

| Battery of 144 pairs plates : |       | No. 18. | No. 16. |
|-------------------------------|-------|---------|---------|
| 100 miles                     | ..... | 35°     | 41°     |
| 90 "                          | ..... | 37°     |         |
| 80 "                          | ..... | 38½°    |         |
| 70 "                          | ..... | 40°     |         |
| 65 "                          | ..... | 41°     |         |
| Battery of plates :           |       | No. 18. | No. 16. |
| 100 miles 72 pr. plates       | ..... | 23°     | 30°     |
| 100 " 84                      | ..... | 26°     |         |
| 100 " 96                      | ..... | 28½°    |         |
| 100 " 102                     | ..... | 30°     |         |

According to the above experiments a wire, No. 18, has capacity to conduct a given voltaic current 65 miles, and No. 16, 100 miles. Suppose the conductivity of iron wire, Nos. 8 and 10, have equal powers as Nos. 16 and 18 of copper, respectively; on a line of 300 miles No. 8, iron wire, can be worked successfully, but the No. 10 could be worked but 195 miles; or, if No. 10 wire can work maximum 300 miles, No. 8 could be worked 461 miles. These facts clearly prove a very great advantage in the use of the larger size wire for telegraphic purposes. This is an important matter, and it is worthy of being very gravely considered by companies having lines on long routes, where long circuits are required. For example, suppose a line to be 900 miles long, using No. 10 wire, a size common on American lines, the practical circuits would be about 300 miles each. If the wire be No. 8, a circuit of 461 miles can be as effectually operated, with a battery of a little more *intensity* than that employed for the 300 miles circuit, and, therefore, the line of 900 miles can be operated in two circuits of 450 miles each. In the use of the larger wire there will be economy, resulting from its increased strength. There will also be a saving of expenses in three years, by the lessening of repeating stations, sufficient to pay for the additional cost of No. 8 wire for the 900 miles of line.

CONDUCTING POWER OF TELEGRAPH WIRES.

Considering the above-mentioned facts, and others observed in my experience, I am convinced that the larger conductor is the best for telegraphic purposes, pecuniarily and electrically considered. On the Bengal lines, No. 1 iron rods are used for conductors, and those lines are successfully worked in long circuits. The philosophy establishing the surface as the part, on or through which the current moves, adds further proof in favor of the larger wire. In practical telegraphing we have had many proofs establishing the advantage of full metallic surface. In Pittsburg, and many other cities, where great quantities of coal are daily burned, the sulphurous vapors arising from such fuel, in a very short time, corrodes the iron wire, leaving but

very small metallic substance to serve as a conductor. These corroded wires have frequently been replaced by new ones, and the increased facility in telegraphing at once realized. To remedy their rapid decay, zinc coated wires have been adopted, and their durability is greatly extended; nevertheless, in time, they too yield to the devouring elements; the sulphurous vapors, passing over the oxyde of zinc covering, convert it into sulphate of zinc, which being soluble in water, is immediately dissolved by the rain and drops off. The wire being thus deprived of its insoluble armor, rapidly corrodes.

#### ADVANTAGES OF ZINC-COATED WIRES.

Many of the American lines have in use zinc-coated wires—commonly but improperly called “galvanized”—and their use has given great satisfaction. The advantages realized from the use of the zinc-coated wires, in the perfection of the joints, are sufficient to compensate for their general adoption. The economy to any company resulting from this one point of consideration is more than can be estimated by comparative values. Besides this, the wire for the whole line is preserved in its full metallic surface, and its conductivity is made even and continuous. On a line of 300 miles, if one mile of the line wire be reduced in size from that of the other 299 miles, the one mile of faulty wire will be a continual retardation to the flow of the current on the 299 miles of good wire. The trials given zinc-coated wire have established, beyond doubt, very great advantages in favor of its use for telegraphic purposes.

Objections have been made to the use of zinc-coated wire, in the Southwest, especially across prairies, where there are no trees to serve as auxiliaries in conducting the atmospheric electricity to the earth. A telegraph wire traversing forests can not be disturbed by atmospheric electricity, while on the other hand, when it traverses open fields, or prairies, it is very liable to serious interruption from that source. The use of the zinc coated wire, across these open plains, affords a greater metallic surface for the atmospheric electricity. If the iron wire was of equal size without the zinc, the result would be in proportion to the conductivity of iron and zinc. It is *not* the zinc that induces the atmospheric electricity to localize upon the line wire. The conductivity of zinc is  $3\frac{7}{10}$  and that of iron is  $5\frac{6}{10}$ . The zinc, it is true, has a great surface or circumference, but that additional surface does not give it an equal power with the iron. It cannot be maintained, therefore, that the zinc is at fault in the premises. If the wire was copper, the interference would be much greater than with the iron

and zinc. From these facts it may be said, that the better the conductor, the greater the interruption. Such a conclusion may be very true, but the cause and effect must be considered philosophically. In Sardinia, the lines have been constructed to meet the case. To each pole is attached a paratonnerre or lightning rod, which conducts to the earth the atmospheric electricity, and they have no interruption to retard the successful working of the lines. It is reasonable to believe, that if earth-wires were run from the tops of the poles into the moist earth, the working of the line wires would not be disturbed by atmospheric electricity. Such an arrangement throughout the line would be expensive, and most likely never will be tried in America, although it would be strictly conformable to established philosophy. From the facts above cited, it will be seen that the use of zinc-coated wires is promotive of the durability and working of the lines, and in no case injurious to successful telegraphing.

Some telegraphers may insist upon the truth of the questionable theory that the brightness of the zinc tends to attract atmospheric electricity. The use of a cheap paint would remedy that objection, and at the same time add to the protection and preservation of the wire. On making the joints, however, care should be taken to remove the paint so as to cause a perfect metallic contact. I am not prepared to believe, however, that the paint would be of any advantage. Dry paint serves as a non-conductor, and when the wire is covered with a film, the whole becomes a Leyden jar. The wire inside is charged and the dry paint acts as the glass of the Leyden jar, and on the exterior is collected the negative electricity from the atmosphere. The presence of this negative influence retards the interior or positive current, and thus the telegraph is disturbed to the extent of the retardation. On ordinary wires, covered with dry oxyde, the same philosophy must be considered. These philosophical considerations are worthy of attention, though, perhaps, their importance may not seem appreciable in practical telegraphing.

CONDUCTORS COMPOSING A VOLTAIC CIRCUIT.

The conductors common to a telegraphic circuit may be considered as 1st, iron; 2d, copper; 3d, brass; 4th, zinc; 5th, tin; 6th, platina; 7th, nitric acid; 8th, water, pure and acidulated; and, 9th, the earth.

1. The principal conductor used by the telegraph is iron. The size of this conductor should be commensurate with the length of the circuits desired.



2. The copper wire used, is confined to the interior of the station, and they should be fully equal in size to the relative conductivity of the iron wire; thus, a copper wire may be  $5\frac{63}{100}$  less in circumference than the line iron-wire.

3. The brass connections should be full, so as to form a contact with the copper wire sufficient to secure an equal conducting capacity with the iron. Usually the connections with the apparatuses through the brass binding screws or posts are greatly at fault, not having as much metallic contact as necessary.

4. The zinc metal in the circuit is confined to the battery, and that part of the circuit is seldom at fault.

5. Tin is used for solder, and though a better conductor than iron, yet the amount of contact is very often inferior, and far more at fault than any other part of the circuit. By studying the table given by Mr. Farmer, the telegrapher can readily determine to what extent he should make the metallic contact with the solder, especially in the battery.

6. The platina strips used in the battery, and in the key, should be sufficiently large to give its full ratio of conductivity in the circuit; and, also, to present surface sufficient to afford contact with the acid, so as to meet the lesser conductivity of the nitric acid held in the porous cup.

7. The nitric acid is placed in porous cells, through which it penetrates. It is necessary to form a contact with the platina, sufficient to give conducting medium equal to the other component parts of the circuit. It will be observed that the conducting power of nitric acid is about 260,000 times less than iron, and the metallic contact with the fluid should be commensurate with that law.

8. The water employed in the battery cells should be acidulated. I have known some operators to collect pure rain-water and use it unacidulated. Of course, as soon as the nitric acid passed through the porous cups, its conducting power was increased. Some telegraphers have supposed that the pure distilled water was the best for conducting purposes and for generating electricity. Many such errors have been practised to the detriment of the working of the telegraph. The acidulated water, in which the zinc is immersed, has about 216,000 times less conducting power than iron, and its contact with the zinc should be equal to the line wire.

9. The earth serves as a half of the circuit. The connection between the earth and the line should be equal to the conducting power of the wire. The earth wire should be attached to copper plates, or sheets, to afford the required surface. Iron

plates would answer if it did not so quickly decay. Sheet iron electro-plated with zinc or copper would answer fully the purpose required. The earth plate, of whatever metal it may be, should be buried in moist earth, and the greater the moisture the better will be the circuit. The iron wire next to and in the earth, ought to be coated with tin or zinc to prevent its decay.

I have, in the foregoing, briefly considered the component parts of the electric circuit; and the practical telegrapher can readily see that he cannot too well understand the philosophy of the media, composing the conductors of the voltaic circuit. A uniformity of the conducting powers will always prove of the greatest value in the attainment of telegraphic success.

## STRENGTH OF TELEGRAPH WIRES.

During the winter of 1858-'9 I instituted a series of experiments testing the strength of various sizes and qualities of iron wires. In these I was most liberally aided by Messrs. Ichabod Washburn & Co., wire manufacturers at Worcester, Massachusetts. This old established firm provided the various qualities of wire and the necessary appliances and help to enable me to effect the most thorough investigation. The average results of

Fig. 1.

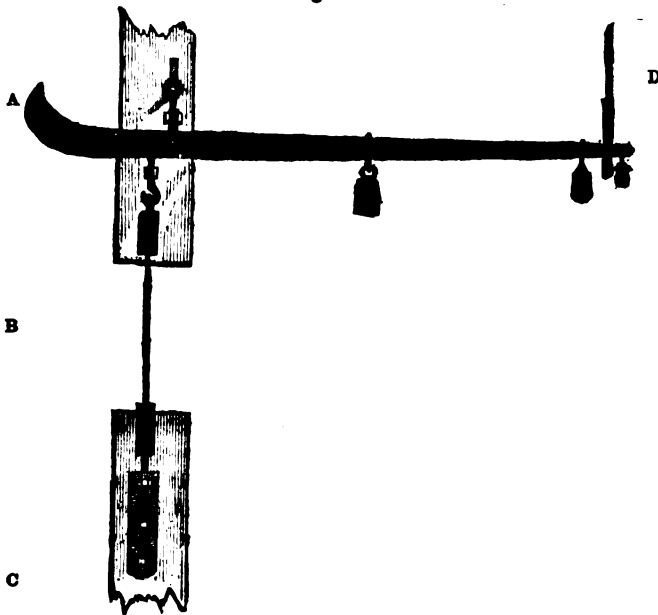

the trials, as to the strength of the wires, are given in the accompanying tables. To test the wire, an ordinary steelyard was employed, as represented by fig. 1 : *a* is a suspended timber, to which was swung the steelyard ; *b* is the wire undergoing the test ; *c* is an upright timber ; *d* is an iron rod fastened to the joist. At the lower end of the rod *d* is an opening through which the beam is passed. This opening is scaled to limit the movement of the beam within a foot. Whenever the wire stretches and lets the beam descend to the lower end of the opening, the screws at *c* can re-adjust the scale so as to allow the weight to again bring down the lever beam to its limit. The wire frequently broke within the clamps, and could not be counted. Only the breaks that occurred at *b* were recorded. The averages of these trials are given in the table. Table 6 shows some tests of wire not as strong as the wire of the other trials. The wire of each kind, viz. : Swedish and American, was from the same qualities and the same lot of iron. The difference in the strength, is owing to the manner of drawing. Messrs. Washburn & Co. have attained this superiority of strength by many years of careful experiment. Most of the telegraph wire used in America is manufactured by these gentlemen, and the peculiar wants of the enterprise have been carefully studied and accommodated by special arrangements. It is important for telegraphers to consider the peculiar wants of their line, and to have the wire manufactured to meet every contingency. Mr. P. L. Moen, of the above-named firm, informs me that the toughness of the wire depends as much upon the drawing, as upon the quality of the metal. I have frequently visited their establishment, and have been highly gratified to see the great care exercised to attain the greatest degree of perfection in the manufacture of the wire to meet the especial wants of the telegraph. The telegraphic enterprise has reason to rejoice that these gentlemen have done so much and are continuing their attentions, regardless of expense, toward the accomplishment of every consideration, having in view the perfection of the art of telegraphing, so far as can be attained in their specialty.

The earlier lines of telegraph were constructed with *annealed* wire. No builder would use *un-annealed* wire, nor would any company have any other kind employed. It was required to be *well* annealed, and the more pliable it was, the more acceptable. The experiments given in Table 4 show how great was the folly of the earlier ideas relative to the use of annealed wire. It cannot be denied, however, but what the wire should be slightly annealed, so that the joints can be made with rea-

sonable facility. The coating of the wire with zinc accomplishes this desideratum, and slightly anneals it. The difference in the strength, between the annealed plain wire, as table 4, as practically required some twelve years ago, and the zinc coated annealed wire, given in the other tables, will be seen to be very considerable.

The trials, given in the following tables, were made with much care, all under my own direction and observation. They are worthy of the telegrapher's careful study:

Table 1.

SWEDISH IRON WIRE.

| No.    | Plain Iron<br>broke at | Zinc-Coated<br>broke at | No.     | Plain Iron<br>broke at | Zinc-Coated<br>broke at |
|--------|------------------------|-------------------------|---------|------------------------|-------------------------|
| 6..... | 2,490                  | 2,300                   | 10..... | 1,430                  | 1,270                   |
| 7..... | 2,370                  | 2,176                   | 11..... | 1,185                  | 1,030                   |
| 8..... | 2,925                  | 1,993                   | 12..... | 1,020                  | 921                     |
| 9..... | 1,748                  | 1,495                   | 18..... | 770                    | 665                     |

Table 2.

ENGLISH IRON WIRE.

| No.    | Plain Iron<br>broke at | Zinc-Coated<br>broke at | No.     | Plain Iron<br>broke at | Zinc-Coated<br>broke at |
|--------|------------------------|-------------------------|---------|------------------------|-------------------------|
| 6..... | 2,050                  | 1,945                   | 10..... | 960                    | 985                     |
| 7..... | 1,670                  | 1,500                   | 11..... | 740                    | 725                     |
| 8..... | 1,580                  | 1,865                   | 12..... | 635                    | 670                     |
| 9..... | 1,270                  | 1,055                   | 18..... | 550                    | 445                     |

Table 3.

AMERICAN IRON WIRE.

| No.    | Plain Iron<br>broke at | Zinc-Coated<br>broke at | No.     | Plain Iron<br>broke at | Zinc-Coated<br>broke at |
|--------|------------------------|-------------------------|---------|------------------------|-------------------------|
| 6..... | 2,390                  | 2,300                   | 10..... | 1,885                  | 1,270                   |
| 7..... | 2,210                  | 2,010                   | 11..... | 1,155                  | 1,043                   |
| 8..... | 1,985                  | 1,820                   | 12..... | 992                    | 832                     |
| 9..... | 1,665                  | 1,520                   | 18..... | 885                    | 641                     |

Table 4.

The following table shows the result of the trials of the strength of some annealed wire, taken from the lot of the English wire :

|                     |       |                      |     |
|---------------------|-------|----------------------|-----|
| No. 7 broke at..... | 1,173 | No. 11 broke at..... | 618 |
| " 8 " .....         | 1,030 | " 12 " .....         | 410 |
| " 9 " .....         | 815   |                      |     |

Table 5.

In 1853 I instituted some experiments at the same establishment, and the following were the average results :

|                      |                      |          |
|----------------------|----------------------|----------|
| No. 10, zinc coated, | broke at.....        | 925 lbs. |
| “ “                  | annealed “ .....     | 875 “    |
| “ Plain              | “ .....              | 1,050 “  |
| “ “                  | not annealed “ ..... | 1,300 “  |

Table 6.

In January, 1859, I tested, at the same establishment, some wire manufactured for commercial purposes from the same quality of bars, from which were drawn the samples tested in the experiments of January and February, 1859. It will be found to be of much less strength than the wire manufactured for telegraphic purposes.

|            | American.  | Swedish. |
|------------|------------|----------|
| No. 6..... | 1,940..... | 2,020    |
| 7.....     | 1,675..... | 1,640    |
| 8.....     | 1,550..... | 1,430    |

## SCALE AND WEIGHT OF TELEGRAPH WIRE.

The mode of measuring wire has not been uniform or based upon any fixed standard. The two leading rules are the Birmingham gauge of England, and the Washburn gauge of America. The former measures the wire by passing it through a fixed opening, between parallel lines; the latter, by passing the wire between steel bars, fixed at an acute angle resembling a very elongated v. The wire descends the opening until its diameter rests against the sides forming the isosceles triangle, and the points marked upon the sides, gives exactly the size of the wire. This gauge is a great improvement over all other forms, because the fractionals can be given. If the wire is  $10\frac{1}{2}$  or  $10\frac{1}{4}$  or  $10\frac{1}{8}$ , the Washburn measure can indicate it exactly.

This novel improvement in measuring the diameter of any sized wire is the recognized gauge of America, and is known as the “Washburn gauge.” The weight of the wire according to this scale is given in the following table:

Table 7.

## WEIGHT OF IRON WIRE PER TWENTY FEET, BY WASHBURN GAUGE.

|                                         |             |                   |             |
|-----------------------------------------|-------------|-------------------|-------------|
| No. 1 weight.....                       | 4 lb. 2 oz. | No. 8 weight..... | 1 lb. 7 oz. |
| 2 “ .....                               | 3 “ 8 “     | 9 “ .....         | 1 “ 2 “     |
| 3 “ .....                               | 2 “ 15 “    | 10 “ .....        | 14 “        |
| 4 “ .....                               | 2 “ 8 “     | 11 “ .....        | 10 “        |
| 5 “ .....                               | 2 “ 5 “     | 12 “ .....        | 9 “         |
| 6 “ .....                               | 1 “ 14 “    | 18 “ .....        | 6 “         |
| 7 “ .....                               | 1 “ 10 “    |                   |             |
| No. 7 weight of iron wire per mile..... |             |                   | 430 lbs.    |
| 8 “ .....                               |             |                   | 375         |
| 9 “ .....                               |             |                   | 320         |
| 10 “ .....                              |             |                   | 250         |
| 12 weight of copper wire per mile.....  |             |                   | 176         |
| 16 “ .....                              |             |                   | 63          |
| 18 “ .....                              |             |                   | 38          |

Table 8.

## WEIGHT AND MEASUREMENT OF ENGLISH WIRE.

| No. | No. of feet per lb.<br>Ft. in. | Birmingham<br>Gauge. | Yards per cwt.<br>about |             |
|-----|--------------------------------|----------------------|-------------------------|-------------|
| 1   | 4                              | 3                    | 140                     | galvanized. |
| 2   | 5                              | 3                    | 170                     | "           |
| 3   | 6                              | 3                    | 210                     | "           |
| 4   | 7                              | 3                    | 240                     | "           |
| 5   | 8                              | 3                    | 275                     | "           |
| 6   | 9                              | 6                    | 320                     | "           |
| 7   | 12                             | 6                    | 400                     | "           |
| 8   | 13                             | 6                    | 450                     | "           |
| 9   | 16                             | 6                    | 550                     | "           |
| 10  | 21                             | 6                    | 730                     | "           |
| 11  | 28                             | 6                    | 950                     | "           |
| 12  | 33                             | 6                    | 1,150                   | "           |
| 13  | 41                             | 6                    | 1,420                   | "           |
| 14  | 55                             | 6                    | 1,900                   | "           |
| 15  | 66                             | 6                    | 2,300                   | "           |
| 16  | 90                             | 6                    | 3,100                   | "           |
| 17  | 17                             | 7                    | 4,000                   | "           |
| 18  | 16                             | 2                    | 5,200                   | "           |
| 19  | 22                             | 2                    | 7,000                   | "           |
| 20  | 33                             | 1                    | 10,500                  | "           |

# GUTTA-PERCHA INSULATION.

## CHAPTER XXXVIII.

Application of Gutta-Percha as an Insulation—Discovery of Gutta-Percha, its Nature, Qualities, and Chemical Properties.

### APPLICATION OF GUTTA-PERCHA AS AN INSULATION.

ALL efforts to insulate telegraph wires for submarine and subterranean lines proved ineffective until the introduction of gutta-percha, a substance of peculiar growth as hereinafter described. I do not propose to determine when it was first applied to telegraphing. In the year 1847 a manufactory of gutta-percha for the insulation of telegraph wires was established in Brooklyn, New-York, by Mr. Samuel T. Armstrong, who had ascertained that the substance was a non-conductor of electricity. Immediately following this scientific fact, machinery was made for the application of gutta-percha to telegraph wires, and a trial of the same was made across the Hudson river in 1848. It was eminently successful, and at the time Mr. Armstrong was so sanguine of the perfection of the insulation, that he published, in the New-York Journal of Commerce in 1848, a proposition to insulate and lay a telegraph cable across the Atlantic Ocean for the sum of \$3,500,000.

Since that time sub-aqueous conductors have been very greatly improved, and minds of great power are still at work for the perfection of submarine telegraphy.

The manufacture of gutta-percha as an insulation was commenced in England about the same time as it was in America, and the establishment in London, under the direction of Messrs. Statham & Co., has done wonders in the progress of the art. They have from the beginning exhibited a degree of enterprise not surpassed by any others in the art of telegraphing. To London and New-York manufactories the telegraphic world is greatly indebted for the degree of perfection now enjoyed in the use of gutta-percha.

Other establishments for the manufacture of gutta percha have been conducted at Berlin, Prussia, and at St. Petersburg, Russia, but the two most prominent are those of Messrs. Stat-ham & Co., in London, and Mr. Samuel C. Bishop of New-York. It is peculiarly fortunate that the telegraph enterprise has as promoters gentlemen of such sterling worth.



[Leaf and Fruit of the Gutta-Percha Tree.]



**GUTTA-PERCHA, ITS DISCOVERY, QUALITIES, CHEMICAL PROPERTIES.**

Gutta-percha—the Malayan term given to a concrete juice taken from the *Isonandra gutta* tree—is indigenous to all the islands of the Indian Archipelago, and especially to the Malayan peninsula, Borneo, Ceylon, and their neighborhoods, where are found immense forests of the tree, yielding this product in great abundance. Its fruit contains a concrete edible oil, which is used by the natives with their food. The gutta (or juice) circulates between the bark and the wood of the tree, in veins whose course is distinctly marked by black longitudinal lines. The natives were originally in the habit of felling the tree when they required a supply, but have been taught by experience that the juice can be obtained by cutting notches at intervals in the trunk, and save the life of the tree for future tappings, as our maples for successive years yield their sap to the sugar manufacturers. The juice consolidates in a few minutes after it is collected, when it is formed by hand into compact oblong masses of from seven to twelve or eighteen inches in length by four to six inches in thickness, and these, when properly dried, are what is known as the gutta-percha of commerce.

It is but a few years since the knowledge of the existence of this ductile secretion dawned upon the world. Dr. Montgomerie, an assistant surgeon at Singapore, observed in the possession of a native the handle of a wood-chopper of such singular material that it awakened his attention, and on inquiry and examination he found it to have been made of the juice of this strange tree—becoming plastic when dipped in hot water, and when cold regaining its original stiffness and rigidity. Within this brief period the exudations of these dense forests have assumed, in America and England, innumerable forms. It is singular indeed that there should circulate in the veins of the primeval forests of Malacca and the neighboring isles, a sap or juice so long a stranger to the civilized world, possessing such extraordinary virtues, and, in so short a period of time, entering so largely and variously into the service of man, and destined to become his servant in a greater variety of forms than any other material yet discovered.

The gutta-percha of commerce is of a light brown color, exhibiting a fibrous appearance, much like the inner coating of white oak bark, and is without elasticity. When purified of its woody and earthy substance, it becomes hard like horn, and is extremely tenacious, indeed its tenacity is wonderful.

Mr. Burstall, of Birmingham, referring to some experiments testing the strength of tubes composed of this material, says:

“The tubes were three fourths inch bore, the material one eighth thick. They were tested by the Water Company’s proving pump, with its regular load of 250 pounds to the square inch; afterward we added weight up to 337 pounds, and I wished to have gone to 500 but the lever of the valve would bear no more weight; we were unable to burst the pipe.” Another gentleman, Mr. Andrew Robertson, of Stirling, says: “I am of opinion that no other material is so well fitted for the above purposes” (extinguishing fires and watering the streets in dry weather) “as gutta-percha; for, although our pressure is perhaps the greatest in the kingdom, being upward of 450 feet, not the slightest effect could be discovered on the tube or joints, while the same pressure on our leather hose sends the rivets in all directions.”

The application of heat to this crude material makes it soft and plastic, and in a temperature of about 200 degrees it becomes quite ductile, when it is capable of being moulded into any desired shape, which it will retain when cool. It can be dissolved by sulphuret of carbon, or chloroform, or if immersed for a time in spirits of turpentine. It is repellent of and completely unaffected by cold water, but is softened and made adhesive by warm water. It is a *non-conductor of heat* and electricity; is proof against alkalis and acids, being only affected by the sulphuric or nitric in a highly concentrated state; while the most powerful acetic, hydrofluoric or muriatic acids or chlorine have no perceptible effect upon its structure or capabilities. This gum has qualities entirely differing from the India-rubber. It cannot be worn out. It can be melted and remelted, and repeatedly remoulded without changing its properties for manufacture or losing its virtue. It is lighter than rubber, of finer grain, and possesses certain repellent properties unknown to that material, and is extremely tough. It disregards frost and displays remarkable acoustic qualities.

In its crude state gutta-percha has no resemblance whatever to India-rubber in appearance, nor are its chemical or mechanical properties the same, nor does the tree from which it is taken belong to the same botanical family, or grow in the same latitudes or soil; yet, from the fact that it could be dissolved and wrought into water-proof wares, many have inclined to the belief that the two materials are identically or nearly the same.

Gutta-percha when immersed in boiling water, contracts in bulk.

India-rubber when immersed in boiling water, expands and increases in bulk.

Gutta-percha juice is of a dark brown color, and consolidates in a few minutes after exuding from the tree, when it becomes about as hard as wood.

India-rubber sap is perfectly white, and of about the consistency of thick cream; when it coagulates it gives from four to six parts water out of ten; it may be kept like milk, and is frequently drunk by the natives.

Gutta-percha first treated with water, alcohol and ether, and then dissolved in spirits of turpentine and precipitated, yields a substance *consistent with the common properties* of gutta-percha.

India-rubber similarly treated results in a substance resembling in appearance gum-arabic.

Gutta-percha by distillation yields fifty-seven and two thirds per cent. of volatile matter.

India-rubber by the same process yields eighty-five and three fourths per cent.

Gutta-percha in its crude state, or in combination with other materials, may be heated and reheated to the consistency of thin paste, without injury to its future manufacture.

India-rubber, if but once treated in the same manner, will be destroyed and unfit for future use.

Gutta-percha is not decomposed by fatty substances; one application of it is for oil vessels.

India-rubber is soon decomposed by coming in contact with fatty substances.

Gutta-percha is a non-conductor of cold, heat, and electricity, and in its natural state is non-elastic, and with little or no flexibility.

India-rubber is a conductor of heat, cold, and electricity, highly elastic and flexible.

The specific gravity of gutta-percha is much less than that of India-rubber, in proportion as one hundred of gutta-percha is to one hundred and fifty of India-rubber.

Chemists who have analyzed them vary a little as to their chemical proportions, but all agree that the chemical properties and mechanical action of gutta-percha and India-rubber are so entirely distinct and dissimilar, that they should never be classed under the same head, chemically or mechanically any more than commercially.

M. Arppe, a celebrated German chemist, says gutta-percha differs in composition from caoutchouc, and that the products of dry distillation of gutta-percha are different from those of caoutchouc. He considers gutta-percha to be a mixture of six resins, which have been formed from a carb-hydrogen.

# TELEGRAPH INSULATION.

---

## CHAPTER XXXIX.

English Telegraph Insulators—The American, the French, the Sardinian, the Bavarian, the Holland, the Baden, the Austrian, the Seimens and Halskie's, and the Hindostan Insulators—Tightening the wires in Asia, England, and on the Continent.

### ENGLISH TELEGRAPH INSULATORS.

IN Great Britain the telegraph enterprise has been under the administration of gentlemen skilled in the science and the art. Every arrangement employed on the lines in that country contemplates permanency and perfection of operation. The system of telegraphing adopted in Great Britain does not require the same organization, in every particular, as necessary for the American lines. This remark may be applied to the insulation at the posts. On the American lines stronger voltaic currents are employed in the working of the telegraphs, and these currents are continuous. On the English lines the electric force is weaker and non-continuous. Besides these facts, there are other reasons which might be mentioned, if necessary, explaining the fact that the telegraphs of the two countries are different, one from the other, and that the requirements of the one are not the same as those of the other.

The invention of an insulation received from the telegraph veteran, Cooke, at an early day, a proper appreciation. On the 8th of September, 1842, he obtained a patent for his particular modes of suspending wire in the air, &c.

The modes described are various, but the principal features were the causing of *zones* of dry wood to exist between wire and wire by the means of artificial boxes or circular sheds like umbrellas, the tightening of wires by certain well-known mechanical means, the use of compound twisted wire, a kind of portable telegraph instrument to be attached to the wires, as also the use of wires suspended under the particular modes

as described and patented, if used for the purposes of sending currents of electricity to work electric clocks, or particular kinds of apparatus connected with certain descriptions of electric telegraphs.

The plan of causing zones of dry wood to intervene between wire and wire was tried and abandoned. It was succeeded by the following method, which was very extensively employed in England.

The following figures will explain this plan: *a a* are arms of wood attached to a post or standard by means of a bolt passing through the porcelain tubes *y y*. *e e* are tubular insulators of porcelain, affixed to the arms by clips of iron. The wires pass through the tubes *e e*, and are thereby insulated. About every tenth post is made stronger than the intermediate

Fig. 1.

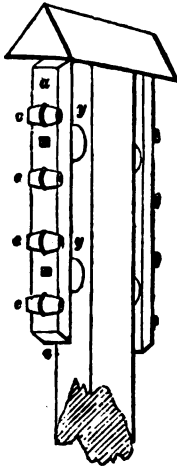

Fig. 2.

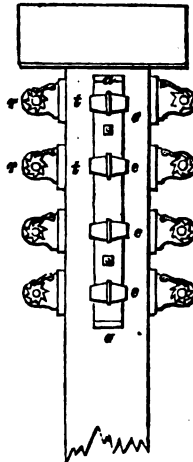
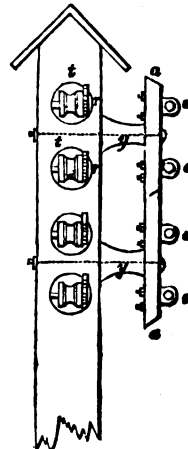

Fig. 3.



ones, and strong cast-iron ratchet-wheels, with barrels, *r r*, are affixed to it for drawing up the wires. When the wire has been threaded through the insulators *e e* on the intervening poles, its end is attached to these winders, and on turning the ratchet wheels round by means of a strong handle, the wire may be wound round these barrels and thus drawn up to any degree of tension desired. The ratchet-wheels and barrels on each side of the posts are connected to each other by bolt *b*, and insulated from the post by means of the porcelain tubes *t t*.

The first plan of insulation adopted by Mr. Cooke was to cover each wire with cotton or silk, and then with pitch, caoutchouc, resin, or other non-conducting materials, and to

enclose them, when thus insulated, in tubes or pipes of wood, iron or earthenware. The telegraph on the Great Western Railway line was originally laid down on this method. This mode of insulation was, however, abandoned on the introduction of the baked wood zones.

The insulator described in figs. 1, 2 and 3, has been known in England as the Cooke Pole system, and fig. 4 represents the insulator as fastened to the pole and the wire run through it.

Fig. 4.

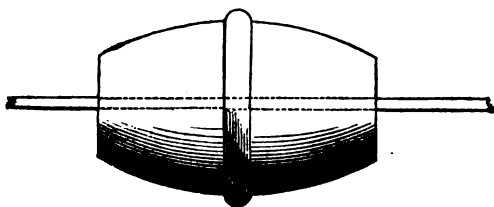

It is formed like an egg, slightly flattened at each end, and about three inches long. The wire had to be run through the holes, and when once on they could not be separated from the wire, except by cutting it or breaking the insulator. This mode of insulation was extensively employed until about 1848, when others were introduced and found to be more practicable.

Fig. 5.

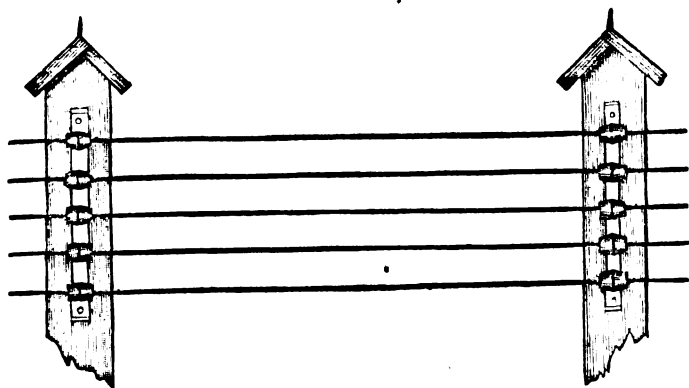
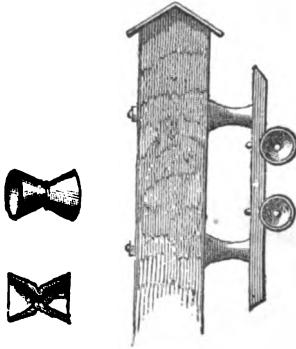

Fig. 5 represents the wire suspended upon the poles through the above described insulator. The wire was fastened at proper distances, the description of which will be hereinafter given.

About 1849, Mr. Physick devised an insulator by which the wire was supported by a hook, the upper part of which passed through a shed of earthenware, and fastened by a nut at the top; above this mastic was laid to insulate the hook from the post. This was found to be a faulty insulator. The vibration of the wires and other causes broke off the mastic.

Fig. 6.



Mr. Charles V. Walker adopted an insulator shaped like an hour-glass, as represented by fig. 6. They were made of brown salt-glazed stoneware, and were fastened to a bracket, as seen by the figure, by several turns of wire passed outside the narrow part of the insulator, and entirely unconnected with the telegraph wire within. The wire threaded the insulator. The bracket is partially insulated from the post. This mode of insulation was a success, so far as pertained to the work-

ing of the line, but the hour-glass shaped cones were liable to break, and when they were thus displaced, the wire had to be cut to thread on new cones. This was objectionable.

Fig. 7.

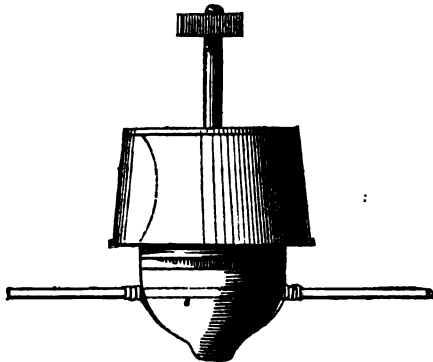

The next insulator adopted was that known as Clarke's, having been patented by Mr. Edwin Clarke, the engineer of the Electric Telegraph Company, in 1850.

Fig. 7 represents the insulator with the wire attached to it. Figs. 8 and 9 are sectional views of it, which I will now explain. Letter A is the arm to which the insulator is bolted by

Fig 8.

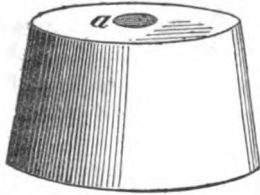
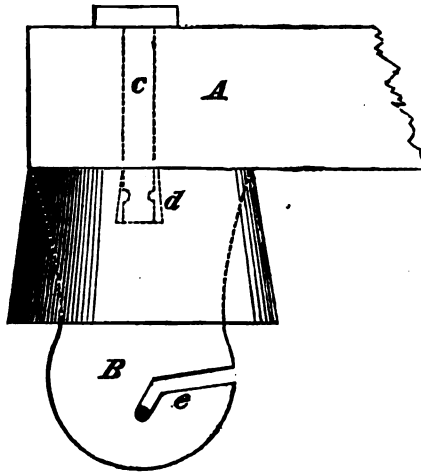

Fig. 9.



means of the bolt *c*, let into the earthenware *B* at *d*. The part *B* supports the wire by the slot *e*. Between the arm and the earthenware is fixed, by passing over the bolt at the hole *a*, a zinc cap of the shape represented by figure 8. The insulator is about four inches long.

Fig 10.

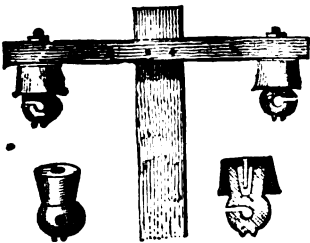
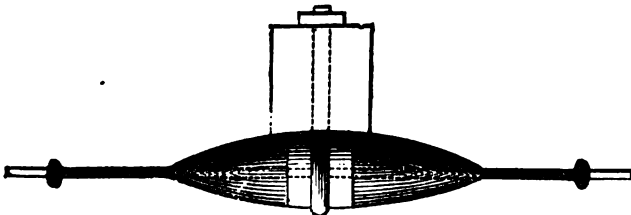

Fig. 10 represents the insulator as fastened to the cross beam and sectionalized.

This form and combination was then followed by another made of glass and suspended from an arm fastened to the post. The object of the application of the zinc or metal cap was that the moisture might condense on it rather than on the earthenware

Fig. 11.





TELEGRAPH INSULATION.

Fig. 12.

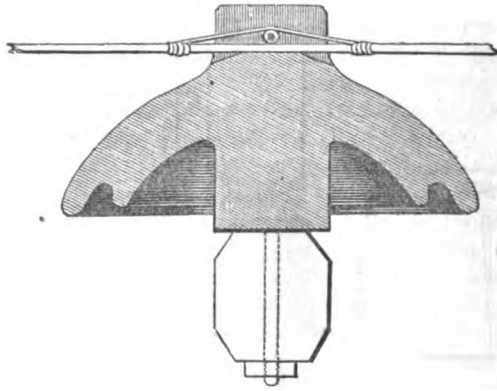
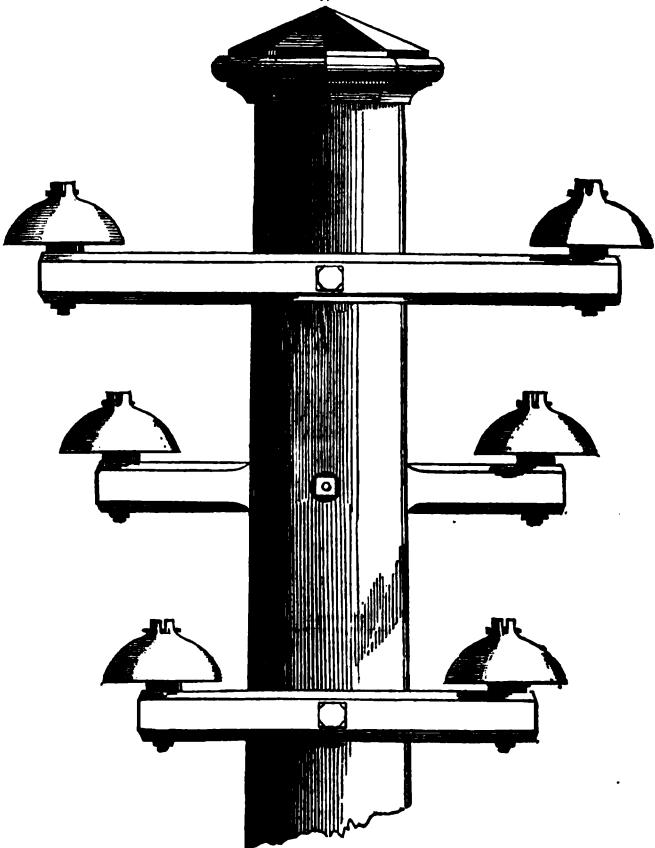

Fig. 18.



Mr. Hightons adopted the plan represented by fig. 11. The wire was capped with silk ribbon for about six inches on both sides of the point of support, and covering about five inches in the centre of the foot of ribbon with a piece of gutta-percha, shaped like an elongated sphere; the whole was then varnished with brown hard varnish.

Fig. 12 represents an insulator invented by the Brothers Bright, of the Magnetic Telegraph Company. It is mounted upon the pole or a cross-beam as seen in fig. 13. The inverted bow is fastened to the beam by a bolt and nut, as seen in fig. 12. The wire is attached to the top. Neither rain nor fog form a connection between the wire and the pole. It is made of earthenware or glass, very heavy, and about five inches diameter. Fig. 13 represents an arrangement for six wires. In connection with this mode of insulation, the brothers Bright devised the arrangement of the cross beams as represented by fig. 13, and also by figs. 14 and 15.

Fig. 14.

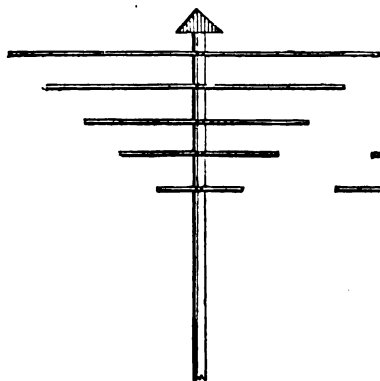

Fig. 15.

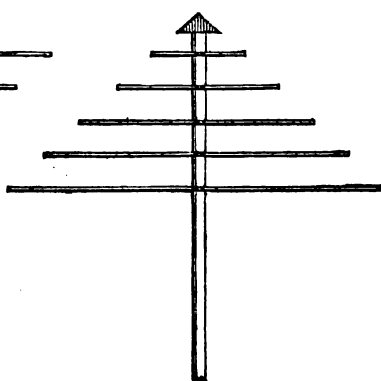

Fig. 14 represents the cross beams or arms reduced in length from the top. Fig. 15 represents the cone above. In either case when the wire breaks it falls clear, and does not get entangled with the other wires, as is often the case when they are on the same perpendicular line. Fig. 14 is a form more convenient for the erection or replacement of the wires. Fig. 15 is a stronger combination than fig. 14, the greater leverage arms being nearer the centre of the pole.

There have been various other insulators invented, and employed to a limited extent on the English lines, but those in general use are described in the foregoing. Gutta-percha insulators were tried, but were not successful, and other forms had

to be substituted in their place. The earthenware insulator has proved to be the most substantial and best in every respect for the purposes of insulation.

#### AMERICAN INSULATORS.

There is a greater variety of insulators upon the American telegraphs than is to be found on the lines elsewhere in the world. The enterprise, from its commencement on the Western continent in 1844, has been in the charge of "many men of many minds," and each has been ambitious to excel the others. This commendable spirit has been productive of much good. Besides this circumstance attending the erection of the lines, different sections of America have required an insulator peculiarly adapted to their special wants. On the other hand, however, there have been devised many kinds of insulators for special sections of the service which have proved destructive to practical telegraphing.

The first insulator used in America was the cloth, saturated with gum-lac, wound around the wire at the post contact. This was on the experimental line, constructed in 1843-'44, between Washington and Baltimore, under the direction of Professor Morse. Copper wires were used, and a cross board was fastened at the top of the pole. A small notch was cut in the top edge of the board, and the wire, covered with the saturated gum-lac cloth, was laid in the notch. Over this was nailed a board, serving as a roof, so that the rain could not have access to the wire contact on the perpendicular edge of the cross-board.

Various plans were suggested for the proper and better insulation of the wires. The horn used for lightning rods was tried and abandoned. Finally the glass was determined upon as the only reliable means of effecting the great desideratum. The question was then as to the form of the glass. On this the opinion of telegraphers are still at variance. Every new man that comes into power seems to aim for a novel form of insulation. This singular infatuation among telegraphers I

Fig. 16.



Fig. 17.



Fig. 18.



have noticed for many years past, and even at this day I find a great diversity of opinion as to the most acceptable insulation.

In the adoption of the glass insulator the form first employed was the ordinary door-knob. It was found to be a partial success, but the large projection at the top of the knob was considered useless, and then the shape represented by fig. 16 was employed. The glass was set on a wooden pin fixed in a cross beam at the top of the pole. This form was then improved as shown by figs. 17 and 18. The wire was laid in the grooves of figs. 17 and 18, and on the projection in figure 16. The line wire was then tied to the glass with a small wire, either No. 16, 14, or 12, according to circumstances and the opinion of the constructor.

Fig. 19.

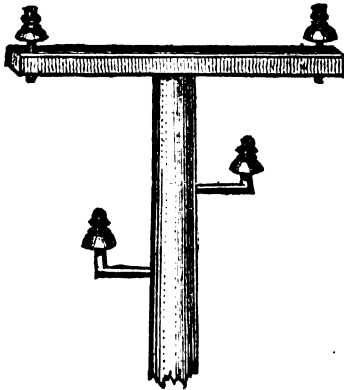

This insulator was again improved by Mr. William M. Swain, president of the Magnetic Telegraph Company. He abolished the flange and constructed the glass in the shape of an egg, as represented by the following figures.

Fig. 20 represents the form of the glass with line wire groove at its centre. The lower end is concave and the upper slightly convex. The flange insulator was easily broken, but the egg form cannot be broken by the ordinary service of the telegraph. I have seen this insulator thrown as much as a hundred yards, and against brick houses, and not break. This rotund-shaped glass insures long service, as has been demonstrated by its use on a long range of lines for many years.

In the arrangement of this insulator Mr. Swain did not only have in view substantiality, but also the perfection of the insu-

lation of the line wire from earth currents. At numeral 1, fig. 21, the cone is concave. When the water collects upon

Fig. 20.



Fig. 21.

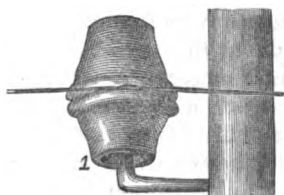
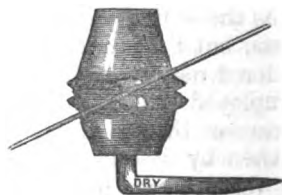

Fig. 22.



the upper part of the insulator it does not follow the glass to the numeral 1, but falls from the centre projection. The moisture under the drip forms globules, and breaks from the cone at or above 1, as seen falling from the flange of the cone, fig. 25. The point of drip, therefore, is not at the lower end,

Fig. 23.

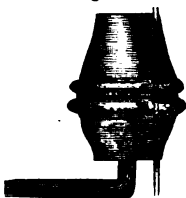
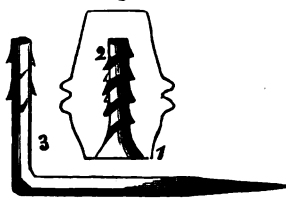

Fig. 24.



but above at the centre projection as just described. Fig. 26 represents the drip of a house. The falling drop breaks the rain and keeps dry the projection seen under the eave of the house. In the same manner the dripping from the above described glass insulates the lower cone from the rain. Of

Fig. 25.

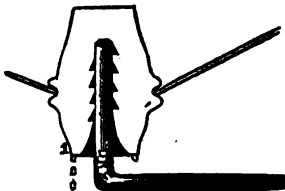
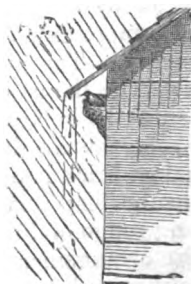

Fig. 26.



course the lower end of the glass will not be dry, but there will be less liability for a watery connection with the earth from the wire than when the drip is at the lower end of the glass. I have seen this philosophy illustrated at the Niagara Falls. The immense volume of water passes over the shelf or point of drip, and beneath the mass of water is a passage-way for travellers, precisely as represented by fig. 26. If the reader desires to see this idea illustrated, he can do so by setting a teacup upon an upright pin, then fill the cup with water until it overflows. The water will fall over the rim, and the smaller end of the cup will be dry.

Fig 21 represents the glass adjusted to the wire when on a right line; fig. 22 when the wire is oblique, as upon the side of a hill, and fig. 23 when the wire is perpendicular with the post. In order to prevent the glass from pulling off from the iron arm, the screw combination represented by fig. 24 was adopted. The iron arm 3, is cut so that the teeth will serve as a male screw. The glass is made with a female screw as seen by numeral 2. Fig. 25 represents the glass on the arm, with the line wire fastened to it at an angle pulling the glass upward, the teeth of the iron arm fitted into the grooves of the screw prevents the glass from being separated from the iron arm.

The above figures are engraved with so much variety that further explanation is unnecessary. They have been gotten up with care, and they are replete with demonstrative philosophy.

Fig. 19 represents the application of these insulators to the poles. The cross beam at the top of the pole has upon it two insulators, set upon iron pins. Some lines have several of these cross beams on the poles for the use of other wires; others have the insulators fastened to iron arms driven into the sides of the poles, as seen below the beam in fig. 19. This iron arm is shaped as seen in fig. 18. An auger hole is bored into the post, and into it is driven the iron arm as seen by the figure. An advantage is realized in the use of this class of insulators, in the fact that there is not much surface for the wind to act upon. Many lines are leveled to the earth by the heavy storms.

Among the improvements historic in telegraphing is the one

Fig. 27.

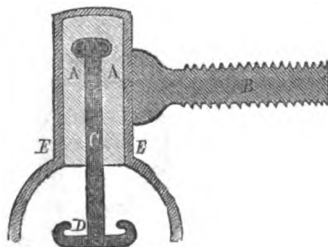

called the brimstone insulator, represented by fig. 27. Letters *A A* are sulphur; *B* an iron arm to screw into the auger hole in the pole or tree. *c* is an iron pendant to support the wire in the eccentric hook *D*. *E E* is an iron casing, and is a part of *B*. The flange below *E E* was to prevent a watery connection in times of rain, dew, or fog. These insulators were extensively used on the early lines constructed by Messrs. Ezra Cornell, John J. Speed, jr., and J. H. Wade of the northeast and northwest. This combination of materials proved to be very defective; and at an enormous expense they had to be removed from the lines and others substituted. The losses sustained by their use were very great, almost producing the ruin of some of the companies. The reader may be surprised to learn that it proved so seriously fatal, and he may be unable to comprehend why it was not found to be defective for telegraphic service before it had been so generally applied. The explanation will be readily understood when it is remembered that these various lines were all being built at the same time, in different directions, by different gentlemen, contending against rivals on the same routes. In the course of a few weeks several hundreds of miles were constructed. It was but a short time before the fault of the non-working of the lines was found to be in the application of the sulphur. The complete failure of these insulators has prevented others from attempting to use sulphur in connection with the insulation of telegraph lines in America.

Fig. 28.

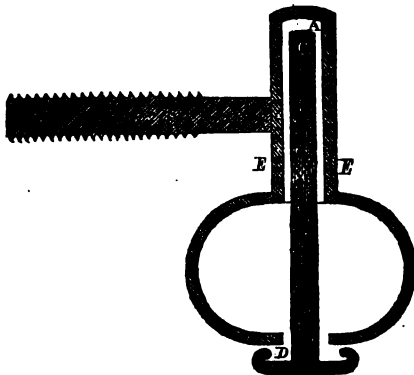

Fig. 28 is an iron insulator, adopted by Mr F. N. Gisborne for the Newfoundland telegraph lines. Its construction is similar to that of fig. 27, except the flanges *E E* are made spherical so as to better protect the pendant from watery connections in wet weather. The inside of the bell *E E* was at first enamelled with a thick coat of glass. The white space seen in the figure

was then filled with lead to hold the pendant *c*. The insulator thus arranged proved to be defective. The enamel soon wore off by the vibrating of the wire in the wind, and the lead coming in contact with the iron, a metallic connection was

formed with the earth whenever the pole was wet, or through the sap when the insulator was fixed into a tree. To remedy this fault Mr. Gisborne applied vulcanized rubber in the place of the lead. In this latter form the insulator has proved to be a success.

The first insulator constructed so as to hold the wire by suspension, on the American lines, was devised by Col. John J. Speed, jr., and used on the line from Detroit to Dearborn, Michigan, in 1849. Fig. 29 represents the form adopted. It was made of a cast iron casing, with a cap *c* to serve as a roof.

Fig. 29.

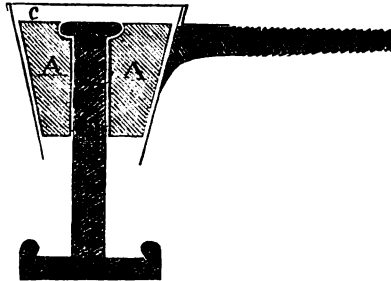

The glass was in two pieces, indicated by *A A*. The pendant *B* supported the wire. The insulator was considered very good, but expensive. This insulator was subsequently improved by moulding the glass in a cylindrical form, and fastening the pendant through the glass with a nut at the top. The glass thus arranged was fitted into a cast iron cylinder, with a moveable iron cap. There were objections to the use of the iron. The next insulator was a cylindrical glass fitted in an auger hole bored into the cross beam. The glass, when fitted into it, was held in its place by a wooden pin, driven through the cross arm, fitting also in a notch made on the side of the glass. This form of insulation has been extensively used on the central range of lines, running from New-York to the West, and has answered as a good insulation.

Fig. 30 represents an insulator very extensively used on the lines constructed by Mr. Henry O'Rielly. It is made of glass, porcelain, or earthenware; the former was found to be preferable. It was about five inches long and two inches across, the groove being made so that the wire could not get out of the glass when subjected to an upward strain, which is often occasioned by the location of one pole lower than the others. The hole through the glass is round and at each end enlarged, forming a funnel or flange. The wire lays upon the centre of the glass, touching not more than an eighth of an inch. The projections seen on the sides at each end are also on the under side. The top is flat. The pole is cut so that the insulator will lay in it, as

Fig. 30.

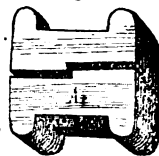



Fig. 31.



seen in fig. 31. An auger-hole the size of the glass is bored through the pole about two inches from the end. With a chisel the wood about the auger hole is cut out, which leaves a mortised opening for the insulator, as seen in fig. 31. Letter *a* is the insulator, with the flange opening; *b* is the projecting head; *c* the groove or hole for the wire, *d* one of two small boards nailed on the top of the pole to form a roof. When trees were used on the route of the line, a bracket was attached to the tree, as represented in fig. 32, excepting that the board roof is not shown in the figure. This insulator allowed the wire to rend through, so that whenever a tree fell upon the line, communication was not interrupted. When the

Fig. 32.



wire is first stretched it is taut, but in a short time it becomes slack by expansion, and whenever a tree falls upon the line the wire is not broken but carried to the earth with the tree. If the wire does not touch the moist earth, the telegraph continues to work without interruption. If, however, the wire is imbedded in the earth, communication will be stopped until the wire is elevated. In forest provinces the open insulator has been found indispensable. In open countries it has not been considered of any advantage.

Fig. 33 represents another combination for insulation. It was adopted by Messrs. O'Rielly, Kendall, Tanner, Shaffner, and others, and was considered on its introduction as the most perfect for the purposes in view. A is the telegraph pole. B an iron roof about four inches wide and six inches long from point of connection with c c c, from which point it is reduced to an arm the same in size as c c c. The part through the pole is round and about one and a half inches in diameter. D is a wedge or key to hold c c c in the pole. E is the insulator made in the form of fig. 30, but only two and one half inches long. The glass insulator E is set in the arm c c c. The projections at the ends and the weight of the wire hold it in the arm. B, the iron roof, mentioned above, covers the glass, so that the rain cannot make a connection with the earth. These insulators were well approved and extensively employed, but in a few months they had to be taken off and others substituted for them. They proved to be more disastrous than the brimstone insulators. They brought ruin on every line that used them. The glass E would easily break, and then the wire resting on the iron arm c c c gave the current an earth circuit whenever the poles were damp; and if trees were used the sap carried off the voltaic current. It was found impracticable to work successfully a line one hundred miles with them.

Fig. 33.

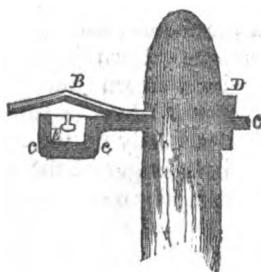

It is impossible for the reader to comprehend the sad results that fell upon the lines that used this insulator. Many thousands of dollars were lost in the constant repair and loss of business. They had to be removed from every line that used them. The telegraphers of the Northwest ever keep in sad remembrance the brimstone insulator, and the telegraphers of the Southwest will never forget the painful history of the iron insulator.

Fig. 34.

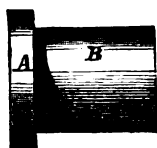

Fig. 35.

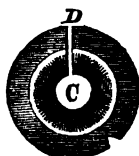
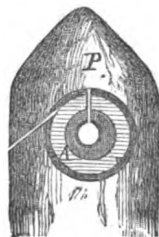

Fig. 36.



Among the open insulators successfully employed on the Southwestern lines was the cylinder form, invented by Mr. John Yandell, and first adopted by Messrs. Shaffner and McAfees on their Southern line, and by Messrs. Shaffner and Veitch on their Western line. Fig. 34 represents the side view of the glass cylinder. *a* the flange projecting one quarter of an inch. *b* is the body of the insulator, made conical, or one quarter of an inch larger at the flange end than at the other. Fig. 35 represents an end view. *a*, the flange, is eccentric to the body *b*. Letter *d* is the groove for the wire to be placed through. *c* is the hole or bed for the wire. The opening at each end is enlarged and funnel-shaped. The notch below *a* is for the nail. To apply this insulator it is necessary to employ two different-sized augers. The first must be the size of the flange, which bores a hole not more than half an inch deep. The other auger, the size of *b*, fig. 34, is then employed, commencing with a centre eccentric to the flange. When the hole is thus bored, with a saw a groove is cut from the side of the pole, as seen at letter *d*, fig. 36. *p* is the pole, cut tapering or in the shape of a roof. *a* is the insulator. *d* is the opening through which the wire is carried to the groove of the insulator. When the wire is in its place, the glass is turned as seen in fig. 36. A nail is then driven into the pole at the notch. The object of the nail and the eccentric flange is to prevent the glass from falling out of the pole and to keep the groove upward as seen in the figure. In order to employ trees on the route of the line, a bracket is made in which is fitted the glass as above described. This insulator has been modified by Mr. J. D. Caton and used on his extensive range of lines in the West. He abandoned the flange and adopted the plain cylinder, and with the nail only the glass is held in the pole.

Fig. 37.



To a limited extent the insulator represented by fig. 37 has been employed. It consists of two rectangular pieces of glass; in each is a semi-cylindrical groove, in which is laid the wire. In the figure the white part represents the two pieces of glass, one laid above the other. They are fitted into a bracket and a small board is nailed to the bracket to serve as a roof. The whole is attached to the post or to a tree.

The House lines have had in successful use the insulator represented by fig. 38. It consists of a glass cap about six inches in length and four inches in diameter, having a coarse screw-like surface cut inside and out. This glass cap, indicated by the numeral 2, is screwed and cemented into a bell-

shaped iron cap marked 1, from three to four pounds in weight, projecting an inch below the lower edge of the glass, protecting it from being broken; this is then fitted with much care to the top of the pole, marked 3, and is covered with paint or varnish. The line wire is fastened to the top of the cap by the projecting iron points, and the whole of the iron cap is thus in the circuit, as the iron wire is not insulated. To prevent the deposit of moisture, the glass is covered by a varnish of gum-lac dissolved in alcohol, and the rim-like form of the glass is to cause any moisture to be carried to the edge and there drop off.

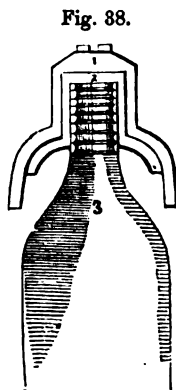

The insulator represented by fig. 39 has been in use for some years on the Boston Fire Alarm telegraph, and has proved to be a success. The cast iron cap is represented by the black line in the section. This is lined throughout with glass, by the operation of blowing, or with porcelain. The shank is then introduced with a hot mass of glass or any fused or semi-fused material, by which it is firmly fixed in its place. This is represented by the shaded portion.

Between the lower edge of the cap and shank, in the section, there are four inches of glass surface. The re-entering angle of the lower part of the cap protects the glass within from missiles, and is calculated, in a storm of wind and rain, to drive the latter downward and thus preserve the insulation. The wires pass over the top of the insulator. The shank, which should be longer than is represented, screws into a bracket or the ridge-pole of a house.

Fig. 39.

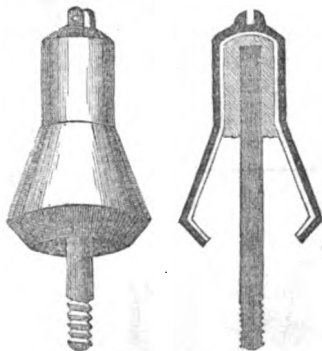

The insulator represented by fig. 40 is called Batchelder's hard rubber insulator. Hard india-rubber has been used for the insulation of telegraph wires for several years past, and has served successfully during the heat of summer and the extreme cold of winter. The seasons have not affected it. This substance does not soften at a lower temperature than 300° F.; it is much stronger than glass, it does not absorb moisture, nor does the dew collect upon its surface as readily as upon glass or porcelain. The figure represents the insulator

in its full size. *A* is a wooden block, in which are the holes *F F*, converging together toward the back, so that the spikes which pass through them are dovetailed to the post. The circular cavity *B* is about two inches in diameter and two inches in depth, within which the lower part of *D C* is protected from rain and moisture. A hole is bored in the block the proper size for the reception of *D C*. The hard rubber *c* covers the iron rod or pendant *D*, so that there can be no metallic or other conducting connection with the earth. The hard rubber cannot

Fig. 40.

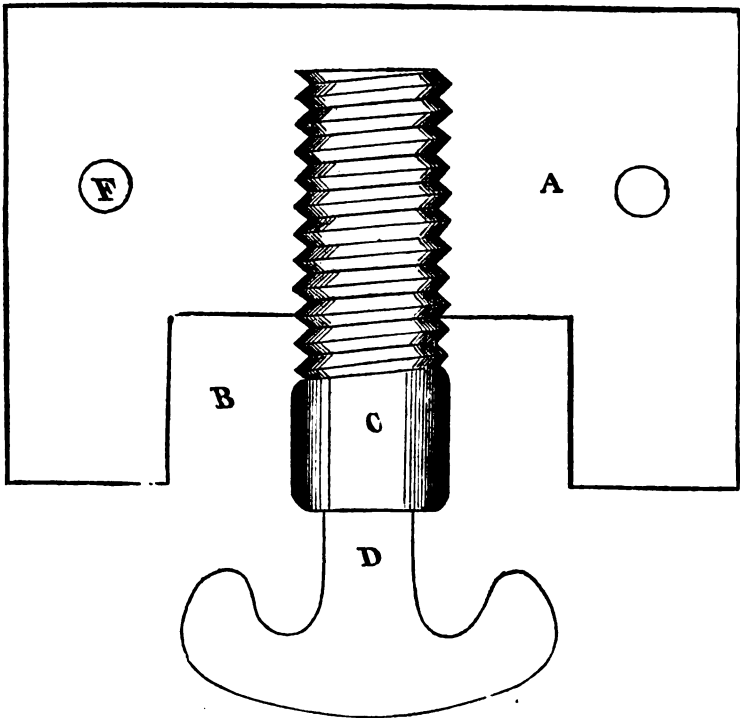

be broken from the iron other than by a hammer or some great force, greater than befalls a telegraph insulator. The line wire is laid in the hook *D*, which has its flanges at angles to hold the wire taut. This insulator has been very extensively used, and particularly in the Northern States.

Fig. 41 represents an insulator used on several lines with satisfactory results. It is made of white flint. The material

is anti-porous, is vitrified throughout, and is considered as perfect for insulating purposes as glass. It is very hard and difficult to be broken, and it has resisted bullets and other missiles thrown at it by mischievous persons. The form adopted has been regarded as advantageous in preventing the gathering of lines of water. The corrugations separate the watery accumulations.

Fig. 41.

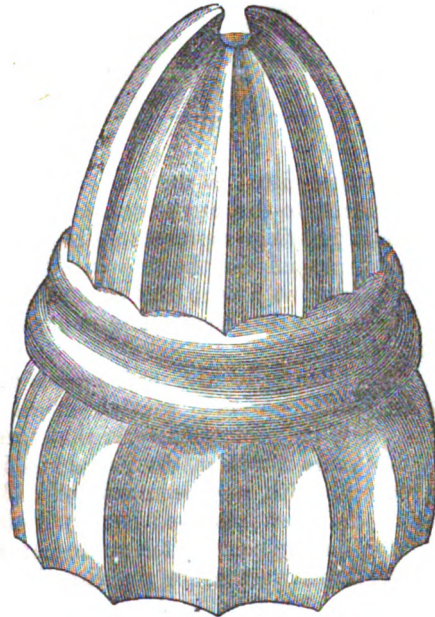

Fig. 42.

Fig. 43.

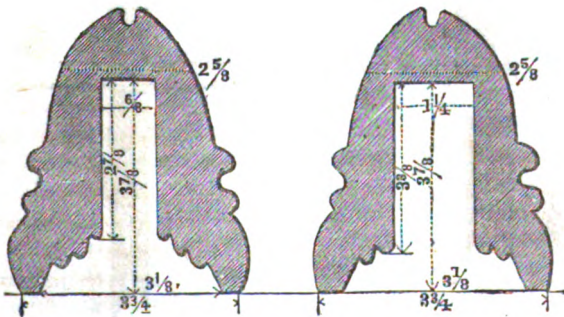

Fig. 44.

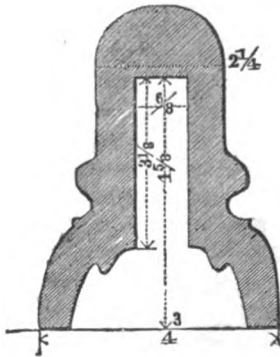
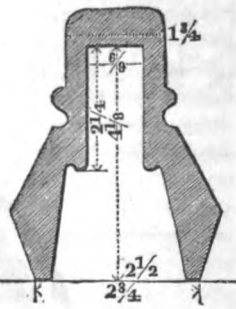

Fig. 45.



The insulator is either fitted to an iron or to a wooden pin, driven into the poles or to the cross-beams.

The four sectional drawings represent different forms adopted. The first two are arranged for the line wire to be fastened to the top of the insulator with wire ties or small wedges. The latter two are shaped so that the line wire can be fastened to the side by tie wires.

In 1849, at Erie, Pennsylvania, Col. Speed, of the Northwest, devised an insulator with a wooden shield covering the glass, having in view its protection. At that time it was but little used. A few years afterward the wooden shield insulator was again introduced with improvements of different kinds. Fig. 46 represents the most improved form, which is known as the Wade insulator, having been gotten up and extensively used on the lines in the Northwest under the direction of Mr. J. H.

Fig. 46.



Fig. 47.

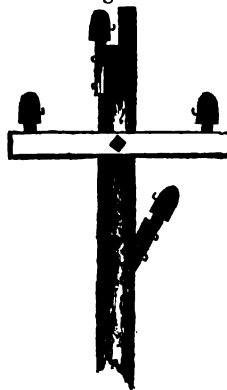

Wade. It is considered the best insulator used on the American lines. It is cheap and very durable. Fig. 46 is a sectional view of the different parts. *a* is a wooden pin one and a quarter inches in diameter, saturated with coal tar and pitch; *b* is the glass, four and one half inches long and two and one quarter inches in diameter outside; *c* is a wooden shield four and one half inches in diameter outside, and six and one half inches long, saturated with coal tar and pitch. *d* is a groove turned around the shield for a tie wire, with which the line wire is fastened. Fig. 47 represents the arrangement of this insulator on the pole by a wooden pin, on cross beams or by a bracket.

Fig. 48 represents a similar insulator, manufactured by Messrs. Chester, of New-York city. *p* is the post; *b* the bracket; *s* the wooden shield, and *c* the glass. The manner of fastening to the post is shown by the figure.

Fig. 48.

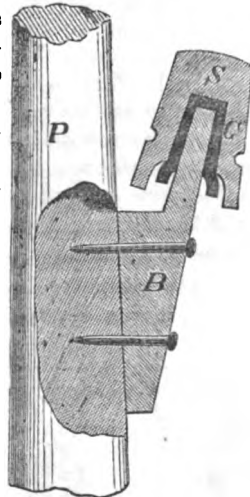

The Wade insulator is used extensively on the telegraph lines in the Northwest, and it is believed by those who have tried it, to have many advantages over all others. The wooden shield, when dry, is a non-conductor, and when painted or saturated with coal tar it remains dry. The glass is protected and seldom breaks. It is strong, and is calculated to give long service. Mr. Wade has had great experience in telegraphing, and he has tried many kinds of insulators on his lines, and he is of opinion that this insulator has proved to be more perfect than any other heretofore employed on the American telegraphs. Expert telegraphers concur in the above opinion.

Porcelain and earthenware insulators have not been used on the American lines. Baked clay, enamelled, was tried, but the vibrations of the wire soon wore through the enamel and the porous clay absorbed water, and they then served as conductors. Nothing but the materials herein stated have been found to answer the purposes of insulation.

#### FRENCH TELEGRAPH INSULATORS.

On the French telegraph lines the bell-shaped insulator has been in general use. Figs. 49 and 50 represent this insulator. In fig. 49 a side and front view is given as it is fastened to the pole. Fig. 50 are sectional views of the same. It is made of



Fig. 49.

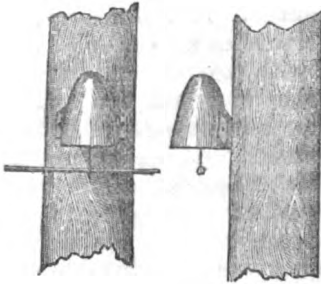
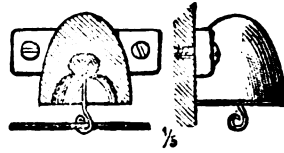

Fig. 50.



porcelain or glass, and it is moulded with two side pieces or ears, through each of which is a hole traversed by a screw about three inches long, which fastens the insulator to the post. The line wire is held by the hook suspended from the interior of the bell. The iron hook is fastened by sulphur into the highest part of the cavity, as seen in fig. 50.

Fig. 51 represents an insulator used on the early lines in France. A slot was made in the insulator, in which was placed the line wire, and then the insulator was fastened to the post. Fig. 52 represents another form, through which there was a hole for the line wire. It had to be threaded on the wire and then fastened to the post as seen in the figure. This was

Fig. 51.



Fig. 52.



Fig. 53.

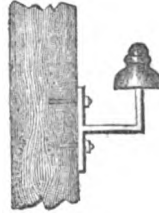
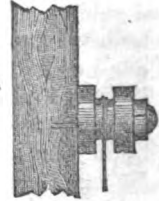

Fig. 54.



called the ring or eye insulator. They have been considered as inferior to the bell form, and are only used at obtuse angles on the line. On the lines examined by me in France, I saw but few of these insulators in use. Fig. 53 is another form of insulation. The line wire is fastened to the bell-formed porcelain by being wound around it and tied by another wire. Each bell or porcelain insulator is fastened to an iron arm with cement. Fig. 54 represents another form. The line wire is wound around the grooved drum or cylinder.

The insulator most common in France is that represented by fig. 49. They are fastened on each side of the pole. I have

seen as many as twelve wires on the same line of poles. They were but a few inches apart. In the working of these wires no difficulties were experienced. It must be borne in mind that in France the battery current is not constantly on the line. If the wires were continually charged, as they are in America, it is possible, and very probable that the wires arranged as above described, would be more or less subjected to cross or induced currents as experienced on many of the duplicate wire lines of America.

## THE SARDINIAN INSULATOR.

Fig. 55 represents the insulation now used on the Sardinian telegraph lines. It is made of glass, earthenware, or porcelain, generally, however, of the latter. It is made with a circular groove around its middle, in which is placed an iron clamp, and the clamp or staple is fastened to a perpendicular wooden beam.

An iron hook, in which is fastened the line wire, is cemented to the interior of the porcelain. This hook, enlarged, is represented by the letter A to the right and at the top of the figure. To this hook is attached a binding screw, which holds the line wire. The perpendicular beams are fastened to the posts above and below with iron bolts, fastening between the beam and the post large porcelain cylinders, as seen in the figure. By this arrangement it is intended to have a double insulation, and I have been informed that it fully accomplishes the end contemplated. In order to further perfect this insulation, it is proposed to place over

the porcelain a cap to serve as a roof. Each pole has its top covered with a wooden or zinc cap, and to each too is attached a lightning rod as seen in the figure. It consists of a large iron wire, made sharp at top and extending above the post about six inches. It is conducted down the post into the earth. Lightning rods similar to the above are also used upon some of the lines in Holland. The extent of their usefulness has not yet been determined. The earth connections have been frequently found to be imperfect. If the rods be connected with

Fig. 55.

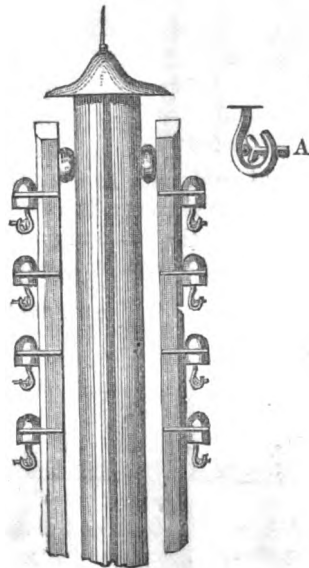

moist earth, commensurate with their conductivity, there can be no doubt as to their efficiency in preserving the line from much, if not all of the annoyance resulting from atmospheric electricity.

#### THE BAVARIAN INSULATOR.

Fig. 56.

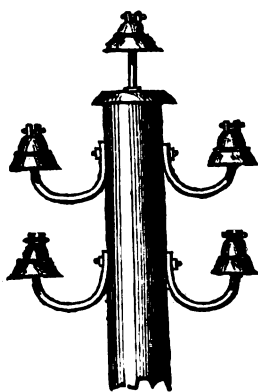
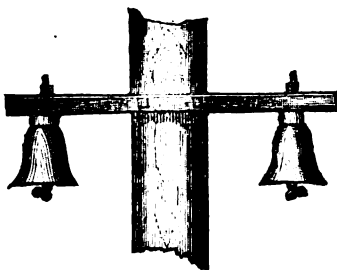

Fig. 56 represents the insulator used on the Bavarian lines. It is a glass bell, fitted and cemented to an iron arm, which is screwed to the post as seen in the figure. To the top of the glass is cemented, in small openings, two cast-iron projections, through which are two holes. The line wire is laid on the top of the glass between the iron projections, and then two wedges are driven through the holes in opposite directions, which securely binds the wire and prevents it from moving upon the insulator. The iron arms are fastened on the sides of the post. Sometimes one bolt, with nuts at each end, fasten an arm on each side, but the metallic connection between the two arms might prove to be disadvantageous to the working of the line. In damp weather cross currents will pass from one wire to the other.

#### THE HOLLAND INSULATOR.

Fig. 57.



On the line from Amsterdam to the Hague, in Holland, is used the insulator represented by fig. 57. It is made of glass, with an iron bolt cemented at the top and fastened to a cross-beam by a nut screwed to the upper end of the bolt. To the interior is cemented an iron pendant for supporting the wire. This insulator has proved its usefulness.

#### THE BADEN INSULATOR.

The insulator represented by fig. 58 is used on the Baden lines, extending from Mannheim on the Rhine, *via* Carlsruhe to Kehl and Strasbourg. The insulator is composed of earthenware, cemented on the top of the pole by plaster-of-paris, as

seen by the sectional fig. 58. The wire is twisted around the neck of the cap. When more than one wire is used on the route, the insulators are fixed to brackets or iron arms.

On the line from Frankfort to Castel, opposite Mayence, I noticed, in 1854, the wire was insulated with a covering of india-rubber, fixed in a notch at each pole. Over the notch was fastened a piece of tin to serve as a roof.

Fig. 58.

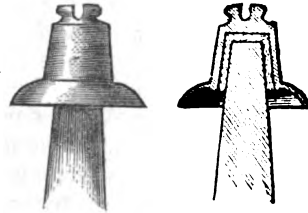

## THE AUSTRIAN AND PRUSSIAN INSULATORS.

Fig. 59 represents an insulator used on some of the Austrian lines. The post  $\tau$  is tapered to a point  $c$ , about two inches in diameter at top, and the tapered part above  $c$  is about six inches long. A porcelain cap or inverted cup is fitted to the tapered end. On the top of the cap at  $e$  there is a small groove or hole  $a$ , in which the conducting wire  $b b$  is fastened.

Fig. 59.

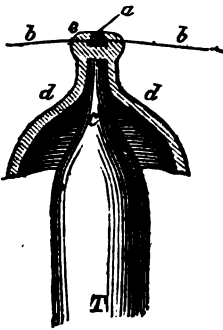
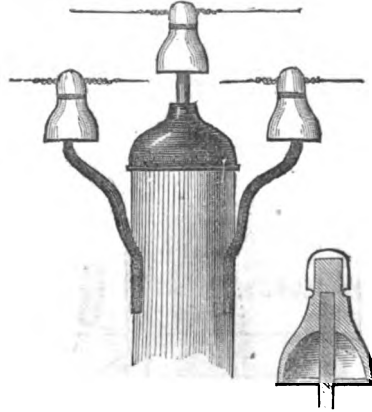

Fig. 60.



The Prussian telegraph lines are remarkable for their perfection as to construction, and particularly in regard to the efficiency of their insulation. Fig. 60 represents the mode of insulating heretofore employed on many of the lines in Prussia and Hanover. The cap is made of porcelain, four and one half inches high, three and one half inches wide below, and one half an inch thick. These caps are fitted to iron arms as

seen in the figure, and the line wire is fastened to the cone with tie wires. On the top of the pole is fitted an iron or earthen covering, through which projects the iron pin for the upper insulator. In its use it has proved to be a good insulator, though the porcelain is very liable to be broken. When the insulating cap breaks, the wire remains suspended to the iron arm, and during wet weather the line is interrupted in its working. These annoyances have been frequent, and to remedy them other contrivances have been invented.

SEIMENS AND HALSKIE'S RUSSIAN INSULATOR.

Until the year 1852, the insulators used on the continent were made of glass, porcelain, or burnt clay. At that time Messrs. Seimens & Halskie proposed the bell-shaped insulator, protected by an iron shield. Those then in use were fragile and easily broken, even after they had been placed upon the poles. Many of them would crack and absorb water, which gave a conductor for the electric current, the means of passing from the wire to the earth, or to the next wire on the same line of poles. These cross currents were very great hinderances to the successful working of the lines, and it naturally became

Fig. 61.

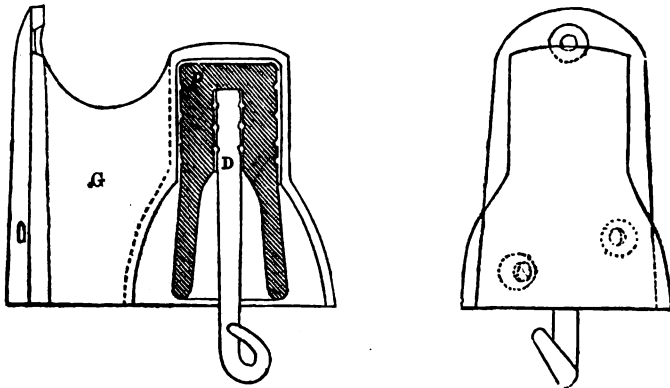

a matter of very great importance to remedy the evil with all the speed possible. To this end Messrs. Seimens & Halskie, gentlemen distinguished for their great telegraphic skill, applied their ingenious minds to the perfection of an insulator that would more substantially subserve the purposes of the telegraphic service. After various improvements in the form and insulating properties of materials, and their combinations, those

hereinafter mentioned were tried and proved eminently successful. It has been estimated that at least twenty-five per cent. of the former insulators had to be annually renewed. This breakage occasioned not only a great expense for their replacement with new insulators, but heavy losses were sustained by the lines not being able to transmit the necessary business of the government, nor that which was offered on commercial affairs.

Fig. 61 represents the common insulator now used on the Prussian and Russian telegraph lines. Letter *g* is a cast iron body. *p* is the china, glass or porcelain insulator fitted into the iron bell. *d* is the wire supporter fastened into the insulating material. The insulator *p*, and the iron supporter

Fig. 62.

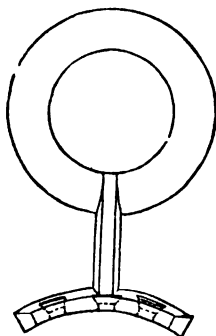
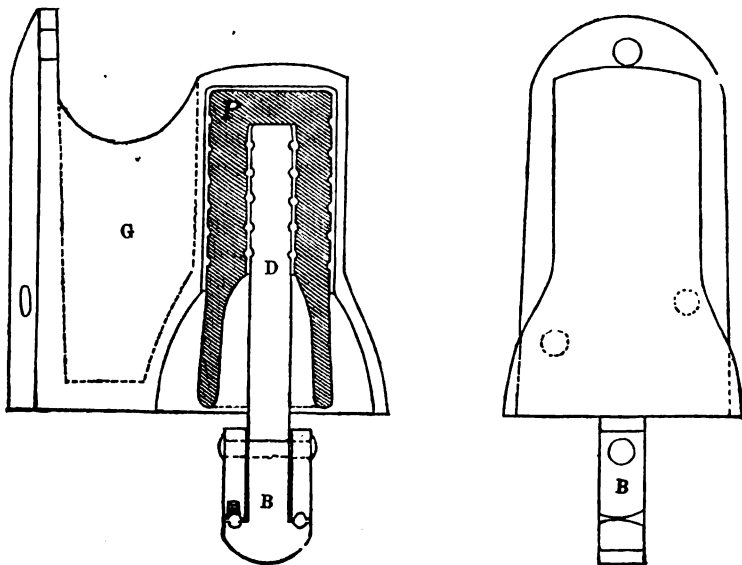

Fig. 63.



*d*, are fastened in their respective places by a mixture of sulphur and colcathar, which makes a good cement, and firmly binds the respective parts to each other. The three views, figs. 61 and 62, are sufficient to represent its construction

without further explanation. Fig. 62 represents the top view and the curvature that fits to the post. The nail or screw holes are marked by the dotted lines. Besides this form of insulator, another is employed for holding the wire taut upon the poles. Fig. 63 represents the contrivance, commonly known as a Spankoff, or tightening apparatus.

Fig. 64.

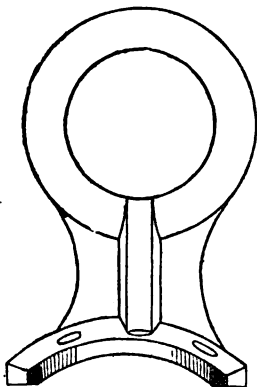

The figs. 61 and 62 are the same in form and make, excepting the wire support *D* of fig. 63 has the klemmbacken, *B B*. The wire is drawn taut, and then *B B* holds it tight and does not permit it to slip through or become loose or sagging. If the wire is cut between two of these insulators, it can only be slack for that particular section, and it does not extend to the sections beyond the spankoffs. They are usually placed on the line, one for each half mile, and sometimes at a less distance.

I have seen these insulators on the German and Russian lines, and wherever they have been employed the telegraph worked with the most complete success so far as pertained to the insulation. The glass *P*, securely insulates the iron supporter *D*, from the cast-iron bell *G*, and the flange mouths of *G* and *P* prevent the collection of water whether in times of rain or of fog.

Fig. 64 represents the top view and the curvature that fits to the post. The nail or screw holes are also shown.

This insulator has proved to be the most perfect as to insulation and permanency used on the continental telegraph lines.

It cannot be broken from the post, and it is capable of sustaining a far greater weight than the wire which it suspends. It is used on the Russian lines, and comports fully with the otherwise substantial structure of those northern telegraphs.

#### THE HINDOSTAN INSULATOR.

On the Hindostan lines, Dr. O'Shaughnessy, Surgeon of the Royal Bengal army, adopted a novel process of insulation, peculiarly applicable to the lines of that country.

The post is tapered so as to be two and a half inches in diameter at the small end, and three inches in diameter at seven inches from the top. The wood is to be roughened with a chisel so as to hold the cement by which the cap is to be attached.

The cap is of wrought iron, galvanized, eight and a half inches high, ten and a half inches in circumference above, twelve and a half inches in circumference below, its lower edge or rim everted to thirteen and a half inches, closed above, and perforated to permit the passage of a screw bolt four inches long and one half inch in diameter. Two strong metal studs, three fourths of an inch in diameter, and one inch long are riveted on the cap, one at each side of the screw, for the purpose of preventing lateral motion of the bracket to be afterward applied.

The cap being inverted, the cement is thus applied. Three parts, by weight of fine, clean and perfectly dry sand, with one part by weight of the best pine rosin, are melted in an iron pot and well incorporated by stirring. The consistence should be that of thick mud. Enough of this cement to occupy half an inch of the cap should be poured in and allowed to cool, which takes about five minutes.

The post is now inverted, and its small end placed on the hardened cement, so that a clear space of half an inch remains between the wood and the cap all round. Melted cement is now poured in so as to fill this space up to the brim. As the cement cools, it contracts slightly, so as to become concave. The post must be kept perfectly steady while the cement is cooling and setting, which occupies about five minutes. It is now ready to receive the bracket.

The quantity of cement used for each cap is one pound fourteen ounces.

Fig. 65.



Fig. 66.

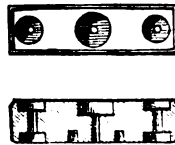

The bracket (fig. 66) is of oak, eleven inches long, four broad and three deep, perforated in the centre for the passage of the cap screw, also perforated at one and a half inches from the end for the passage of the binding screws for the attachment of the iron rods, and having on its lower surface two cavities, one inch deep, three fourths inch wide, to receive the studs of the cap. On the upper surface a circular hollow is sunk at each end, one half inch deep and one and one half inch in diameter, to receive the necks of the porcelain insulators, subsequently described.



The bracket is now placed on the cap so that the studs sink into the holes to receive them, and the nut is firmly screwed down so as to countersink in the substance of the bracket.

The post is now ready to be mounted in the screw pile; but it is more convenient to describe in this place the application of the insulators to be used on the final completion of the double line.

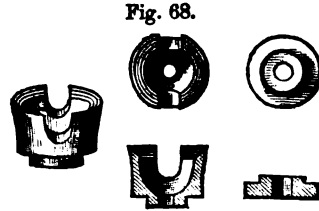
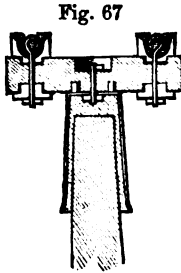

The insulators, (fig. 68) are of brown stoneware, glazed, and consist of two pieces. The larger, of the form shown in section in the cut, is three inches high, including the neck; two and one half inches in diameter above; the neck one and one half inches diameter, perforated vertically to allow the passage of a half-inch screw, traversed by a groove three fourths of an inch wide and one inch deep, to receive the telegraph rod, and hollowed out internally, so that after it is in its place, and its binding screw secured, the cavity may be filled with the melted cement previously described.

The insulators are placed in the brackets as shown, and their binding screws put in loose, ready to be used when the line rods are set in their position.

The line binding screws are five inches long, of one half inch iron, galvanized. They clasp the lines securely in their place.

These insulators are not, however, to be used on the line in the second stage. This, it is to be remembered, affects only the erection of a single line, for which the metal cap insulator is sufficient; but in this case the bracket requires to be surmounted by a piece of wood two inches thick, fastened by screws, and grooved on its surface. Into this groove, precisely over the centre of the post, the line rod is placed. It requires no binding screw in this stage of the operations, but a second piece of wood should be cleated down on the first after the rod has been placed.

## TIGHTENING THE WIRES IN ASIA.

As a part of the insulating appliance, I will here explain the manner of tightening wires on the Asiatic, European, and African telegraphs. That of the latter, however, is the same as adopted in France.

On the Hindostan lines the following is the process adopted for tightening the wires :

Whenever a strong tree is available, it can be made use of in the straining operation. If it be necessary to strain on one of the line-posts, four strong props should previously be applied, to prevent its being drawn out of the ground. The post is on no account to be notched for the props, but a cast-iron clamp is to be screwed round the post, against which the props may lean. A post, the collar, and two of the props, are shown in the accompanying cut, fig. 69.

Fig. 69.

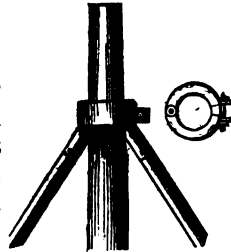

The operation of straining is very greatly facilitated by the use of temporary intermediate props. As the flying line will afford a large supply of bamboos or other light timber, these may be used crossed, like "shears," or the supports of lines for drying linen. The greater the number of these employed, the easier is the straining, and the less is this liable to injure or dislocate the permanent posts.

When required, it is best performed by the erection of a temporary but very substantial straining post of saul or teak timber, seven or eight inches square. One of these, placed on a truck with four wheels, should accompany each party. The beam is twenty-two to twenty-four feet high, shod by a screw pile six feet long, and has two grooves at top four inches deep, to receive loosely two double-eye bolts, each twelve inches long, of half-inch galvanized iron. The post is erected under the lines at a place convenient for the erection of the scaffolding, and at the lowest part of the line to be braced up. The post is screwed six feet in the ground, and its top rises *between* the two line rods, which are then firmly clamped to the post by two powerful screws, which pass through it from side to side. The screw clamps are four inches apart, and a wedge of iron is driven in between to aid in preventing the slipping of the rod.

A platform or scaffold of loose poles and boards is now erected about the post to support the workmen and the straining apparatus. The post rises *above* and *between* the rods to the height which the line is to be when braced tight up.

A straining screw and vice, shown in detail in the cut, fig. 70, are now secured on the post below the eye-bolts by the iron arm, and both line rods are seized in the jaws of the double vice, which is then screwed up by the winch, thus bracing the wires two feet. The jaws of the stationary vice, through which, previously loosened, the rods have moved freely, are now tightly screwed together, so as to retain the rods while the main screw and moveable vice are loosened and returned for another journey.

Fig. 70.

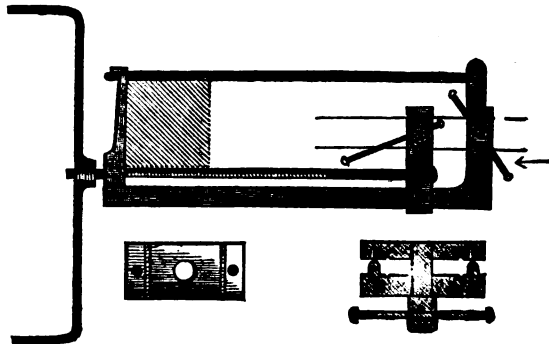

The portions of the rods between the moveable arm and the post are now in loose loops between the post clamps and the stationary vice. By relaxing one of the post side-screws, the loop may be brought up so that it can be cut in the centre between the side-screws, and each end be passed through the eye-bolt resting on the groove at the top of the post.

A second journey of the bracing screw should now be made, the portion of the rod gained secured, and the apparatus turned in the opposite direction to strain on the other side. This alternate straining should be carried on till the line is braced, so that the lowest part subject to the strain shall be sixteen feet clear above the ground.

Temporary props being now placed under the lines near the straining post, *this is removed*. The ends of the rods are turned into hooks on the eye-bolts, and an ingot of zinc is carefully cast over each hook, in the manner already pointed out.

The temporary props and scaffolding are now to be taken away. This straining operation is to be performed as sparingly as possible. Moderate curves on the line are not objectionable. All that straining is required for is to elevate the lowest part above sixteen feet from the ground. The application of the straining apparatus once in a mile will be amply sufficient.

During the straining, men should look carefully along the posts, half a mile at least at each side, to prevent any locking of the rods on the insulators, or distortion of the brackets and caps. When the bracing is complete, the screw bolts on the insulating caps should be screwed tightly up, and melted cement poured into the cavity; finally, a layer of cement one inch thick should be poured all over the top of the bracket.

## TIGHTENING WIRES IN ENGLAND.

On the English telegraph lines the wires are tightened at winding posts placed at convenient distances, usually about a half mile apart. An iron bolt passes through the post, but clear of the wood, having at each end a winder, as shown in the figure, consisting of a grooved drum with a wheel and ratchet attached. The winder heads are kept away from the posts by earthen collars, through which the bolt passes. The winder and bolt being of galvanized iron, constitute a continuation of the metal circuit, and the current passes on through them, as shown in the upper wire. But as the joints of the winder may corrode or form *bad contacts*, and as dust may

Fig. 71.

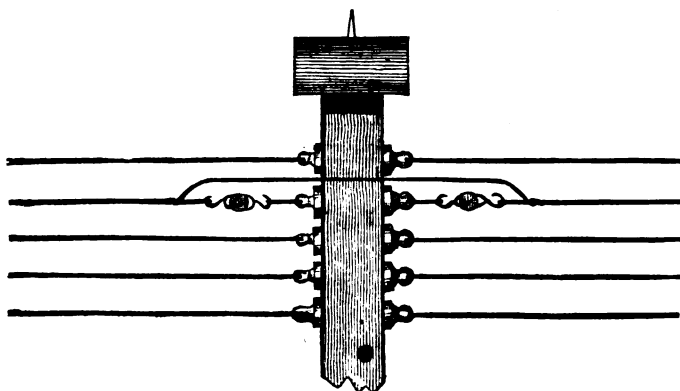

accumulate round the collars and form a receptacle for water, it has been found better to use the winder merely as a winder; to insulate it altogether from the wire; and to provide a side path to take the current onward from one side of the post to the other. This plan is shown in the second wire. The pulley-like appendage, or, as it is called, the *shackle*, consists of an earthen ring furnished with two hooks; the connections of one

of which pass *round* the ring, and those of the other *through* its centre, so that the hooks are effectually insulated from each other, and no current can pass from one to the other. The wire is cut, and the shackles are inserted one on each side of the post, so that the post is now doubly cut out of the circuit. A thin wire is then soldered over from the outside of each shackle, and along this wire the current can pass. The posts are placed at every quarter of a mile. Half the number of wires are wound at each post, and the other half pass on to the next, being sustained on this post as they pass by an arm at the back. Each wire, therefore, is wound in half mile lengths. The lengths are made up of pieces of wire looped and bolted together, with a short wire soldered over the joint. Similar apparatus is used at bridges and tunnels; but is supported by the masonry instead of by standard poles. The points, visible above, are connected with the earth by a wire to protect the poles from lightning.

#### TIGHTENING THE WIRES IN FRANCE.

The winding apparatus used on the French lines is represented by figs. 72 and 73. The latter is a porcelain or earthenware support fastened to the post. The section to the left is a front view showing the screw heads and the cross-bar run

Fig. 72.

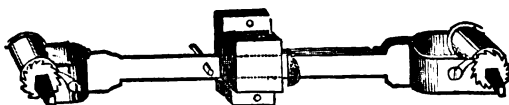
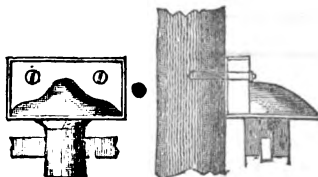

Fig. 73.



through it. The section to the right is a side view and, the lower part shows the oblong opening for the cross-bar seen extending through the section on the left. The lower part of the section to the right is imperfect. Fig. 72 represents the metallic binding apparatus. At each end is a revolving drum, with a ratchet attachment. The section to the right has two

iron arms or bars; the one to the left has but one. The two sections are made in separate pieces, and are united by fitting the arm of the section to the left between the two arms of the section to the right. They are held fast by cross-pins, keys, or screw-bolts. These arms are fitted through the oblong hole seen in the sections of fig. 73. The line wire is attached to the respective drums at the ends of fig. 72. A crank is applied to the projecting heads of the drums, and the wire is then wound around them, and the ratchet catch holds the drum, preventing it from turning back. The voltaic current is conducted from wire to wire through the iron work of the figure.

In order, however, to make the circuit more reliable, sometimes a wire is run from one side to the other, as seen in fig. 71. There are other contrivances used in Europe for the tightening of wires, but sufficient has already been given to explain the mode, the objects and purposes of this process in telegraphing.

On the German lines, a similar contrivance has been used for the tightening of the wires. The mechanisms for tightening the wires have generally been disconnected from the line, only applied for the special purpose at the special time.

# PARATONNERRE, OR LIGHTNING ARRESTER

## CHAPTER XL.

Lightning on the Telegraph—Highton's Paratonnerre—Reid's American Paratonnerre—Various Apparatuses on American lines—Attachment of Paratonnerres at River Crossings—Incidents of Lightning striking the Line—Steinheil's, Fardley's, Meisner's, Nottebohn's, Breguet's, the French, and Walker's Paratonnerres.

### LIGHTNING INTERRUPTING THE TELEGRAPH.

EARLY after the establishment of the electric telegraph, its operation was found to be materially interfered with by atmospheric electricity. So great and so frequent were the interruptions that it commanded at once the study of the ingenious telegrapher to devise an efficient remedy for the serious evil. In Europe contrivances were invented and successfully applied. The rapid spread of the American lines presented opportunities for witnessing the effect of atmospheric electricity in different latitudes and longitudes. Lines traversing several hundred miles, north and south, were subjected to repeated and almost constant interruptions. The adjustment of the apparatus had to be changed from moment to moment. In the transmission of a word, it was quite common to change the adjustment for each letter. The hand had to be on the adjusting screw nearly all the time. In some seasons such impediments are experienced at the present day, and it is not supposed to be possible to overcome the difficulties in question. The sudden charge of the wires with electricity, commonly termed lightning, frequently proves to be of serious consequence not only in the working of telegraph lines, but also in its destruction. It has been very destructive to the apparatus, sometimes totally destroying it, and at other times it has temporarily rendered ineffective the electro-magnet.

In America, the lightning has been more fatal with the telegraph lines than has been experienced in Europe. In

England it has been occasionally very destructive, and many of the wire coils or bobbins have been torn to pieces by it.

Among other circumstances, Mr. Highton, a distinguished telegraph electrician, has related the following :

The lightning struck the line, and traversed it through one of the stations, and in its passage it did considerable damage, and especially to the telegraph instrument at the station, fusing some of the metal work therein. It thence proceeded by the telegraph wires to the ground at the next station, Thrapston, a distance of more than eight miles. At this station also considerable damage was done to the telegraph instrument; several of the wires, and some of the metal-work, were fused.

Fig. 1.

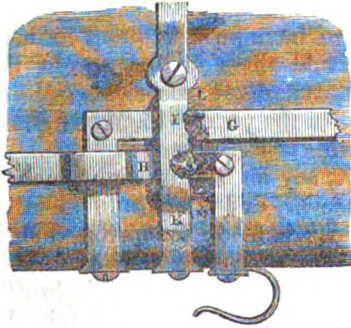

Fig. 2.



Fig. 3.

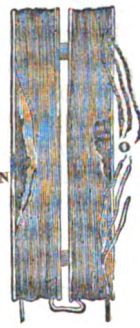

Fig. 1 is a top view of part of the telegraph apparatus at the Oundle station of the London and Northwestern Railway. The strips of brass *g* and *h* were in metallic communication with the wires on the line. The strip *k* was in communication with the ground at Oundle. The strips *g* and *h* were separated from *k* by an interval of about one-tenth of an inch. A flash of lightning was intercepted by the wires on the line, and conveyed to this point; but, although the strips *g* and *h* had metallic communication with the earth at Thrapston and Peterborough, yet the resistance offered to the discharge along these directions was such as to cause a large portion of the electric fluid to shoot through the interval between *g* *k* and *h* *k*, and to fuse the metals, and produce the effects shown at *g*, *h*, *i*, and *k*. The upper bridge-strip *i*, *k*, and the portion of *H* under it, have both been melted, and are now firmly united together by the molten metal. The strip *g* had its surface fused, and the strip *i* was melted also. The wood is scorched from *L* to *M*. There is also a melted spot at *N*, on which another portion of the apparatus rested.



Fig. 2 is a front view of one of the coils of the telegraph instrument at the Thrapston station of the London and North-western Railway.

This coil was burnt and fused on the 1st of August, 1846, by the same flash of lightning which damaged the apparatus shown in fig. 1, although it was more than eight miles distant therefrom! The lightning was conveyed along the wires of the telegraph. The small wires in this coil were fused together, and the silk and cotton burnt off, as shown at *L* and *M*.

Fig. 3 is a back view of the other coil in the telegraph instrument at the Thrapston station. Damages similar to that in fig. 2, will be observed at *N* and *O*. The fine wires were all melted together, and the silk and cotton burnt off.

#### HIGHTON'S PARATONNERRE.

Such occurrences as the above have been frequent in both Europe and America, and to avoid them or to prevent the damaging of the telegraph apparatus, divers contrivances have been from time to time applied. In the year 1846, Mr. Highton successfully employed the following arrangement :

A portion of the wire circuit, say for six or eight inches, is enveloped in bibulous paper or silk, and a mass of metallic filings in connection with the earth is made to surround such covering. This arrangement is placed on each side of a telegraph instrument at a station. When a flash of lightning happens to be intercepted by the wires of the telegraph, the myriads of infinitesimally fine points of metal in the filings surrounding the wire at a station, and having connection with the earth, at once draw off nearly the whole charge of lightning, and carry it safely to the earth. This arrangement at once prevents any damage to the telegraph instrument. Not a coil under Mr. Highton's charge has been fused where this plan has been adopted. The cheapest method is as follows : Line a small deal box, say six or twelve inches long, with a tin plate, and put this plate in connection with the earth ; fill this box with iron filings, and then surround the wire (before it enters a telegraph instrument) with bibulous or blotting paper, as it runs through the centre of the box. All high-tension electricity collected by the wires will at once dart through the air in the bibulous paper to the myriads of points in the iron filings, and thence direct to the earth, and thus the telegraph instrument will be rendered incapable of being damaged even during the most fearful thunder-storms that may occur.

## REID'S PARATONNERRE.

Early in the year 1846, Mr. James D. Reid, an expert telegrapher at Philadelphia, devised a contrivance for arresting the lightning. This gentleman had opportunities of witnessing the effect of the most severe thunder-storms upon the wires. Many times, when the heavens without seemed to be free from storm, his apparatus gave signs of heavy lightning, miles distant. These charges sometimes were sudden and destructive. The frequency of such accidents caused Mr. Reid to perfect the following arrangement, which was applied with the most complete success. The Franklin Institute of Philadelphia awarded to Mr. Reid a silver medal in consideration of the distinguished service thus rendered in the advancement of the telegraphic science. Mr. Reid describes the apparatus as successfully employed on the telegraph lines by him, as follows, viz. :

*Description.*—*k* and *m* are pillars of brass, secured upon a wooden platform, six inches apart.

The wire marked *l* leads to the telegraph machinery of an office.

The wire marked *n* leads to the earth, and is used as a lightning-rod, and of large size.

Fig. 4.

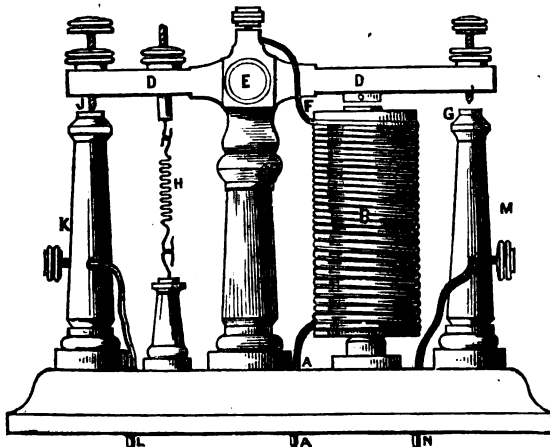

*D D* is a beam of brass, swung over the brass pillars named, *m* or near the centre, by two pivot screws, of one of which, *E* represents the head.

*J* and *G* are adjustable screws on the extremities of the

moveable beam, and so adjusted that only one point of one screw can touch one of the brass pillars at a time. Thus, when *J* is down, there is no metallic contact at *c*, and *vice versa*.

*H* is an adjustable spring, which not only has to overcome the equipoise of the brass beam, producing metallic contact at *J*, but resists the ordinary magnetism of a battery current, passing through the magnet marked *B*, when that magnet is placed in the circuit of a telegraph line.

*c c* are the faces of the magnet and armature, the latter being affixed to the moveable beam *D*.

In placing this apparatus into use, the air wire, as it is usually called, or wire coming in from the line, is connected to the wire of the magnet *B*, marked *A*, which is coarse, that is, number sixteen, silk or cotton covered wire.

The circuit is continued by connecting the other terminating wire of the coil of the magnet to the moveable beam *D*, which being brought in contact with the brass pillar *K*, at the point of the adjusting screw *J*, leads to the wire marked *L*, which connects immediately with the machinery of the office.

During all ordinary circumstances, the apparatus thus described remains quiescent, the spring *H* being so adjusted that the current of the line has no effect in moving the beam, by the production of magnetism at *c*.

When, however, a flash or charge of atmospheric electricity enters the office, it having to pass through the magnet coils *B*, before reaching the office machinery, magnetism sufficient is instantaneously produced to overcome the power of the spring *H*, separate the connection at *J*, and establish, for an instant, connection at *c*, where the atmospheric electricity is at once discharged.

No sooner has this been effected than the spring *H* immediately restores the connection of the line.

This apparatus has been proved on many occasions, and once, during the existence of a severe storm, before a committee of the Franklin Institute at the telegraph office in Philadelphia.

The objection urged against it, that the exceeding rapidity of the progress of the fluid would prevent the apparatus from changing its direction, as contemplated by it, and which appeared to have a reasonable basis, has no reality in the experiment. Communication has been maintained among most violent storms thereby, when adjacent magnets were destroyed.

The following is the manner in which it was arranged at the exhibition in the Chinese Museum, in 1846. The vases

were intended as an additional means of discharging the wild electricity of the atmosphere. To explain:

The vases were filled with water, acidulated slightly with sulphuric acid.

The wires from the line on the one side, and from the machinery of the office on the other, as well as those leading from each side of the apparatus which was placed between the jars, were of good large size.

On the contrary, the wire made to traverse the water in the spiral form, shown in the sketch, was of the finest description.

Fig. 5.

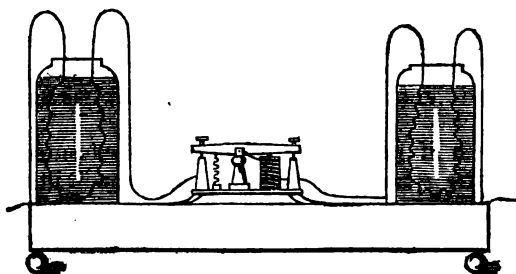

This small wire, if immersed, would at once be melted by the passage of an electric flash. Immersed, however, it was hoped that the fluid would use the acidulated water as part of the circuit, decomposing it in part, and being itself partially decomposed, and tamed by explosion at the surface.

This, I have no doubt, it did to some extent, but deeming the apparatus sufficient without them, I never subjected them to careful trial.

If lightning could be made to discharge itself on the surface of a body of water, it would be an easy mode of drawing off this grand enemy of magnets, and of the regular operation of the lines.

#### VARIOUS AMERICAN PARATONNERRES.

Various other contrivances have been resorted to by the telegraphers of America to effect the protection of the apparatus, and many of them have operated with success. One of these was the employment of a very small copper wire, about three feet long, placed in the line circuit before the electro-magnet. Within an eighth of an inch of the large line wire, an earth wire was placed. When thus arranged, the lightning would burn the small wire and leap to the earth wire, and thus pass off. Sometimes the earth wire was surrounded spirally with

the small insulated copper wire. I never knew of any of the apparatus to be burnt when thus protected. There was, however, a disadvantage in the insertion of the small wire in the line; it served as a resistance or hinderance to the flow of the voltaic current.

Some lines, both in Europe and America, have used a protector made of two brass plates, with saw-teeth edges, screwed to a wooden base, so that the teeth would nearly touch. One of the plates is in the line circuit, and the other is connected with the earth. Between the brass plates and the coils or bobbins is placed a very small copper wire, less in size than the wire around the coils. The lightning enters the office, passes through the brass plate, and burns the small wire. The plus charge passes off to the earth wire, the saw-teeth serving as attractive points for the lightning to leave the brass plate and pass off to the earth. This arrangement has served quite successfully.

Another form of paratonnerre has been used on some of the lines, called the "brush protector." It is made in the following manner: A piece of leather, about four inches long and two inches wide, is pierced with small wires, making a brush. The leather is then fastened to a brass plate, so that the wires under the leather will touch the brass. Another plate with the wire brush attached is placed so that the teeth of small wires will almost touch those of the other. One of the brass plates is in the line circuit, and the other is connected with the earth. When the lightning strikes the line, it passes from the wire teeth of the one brush to the other, and thence to the earth.

The preceding form of paratonnerre has not been in very general use, and in fact all others have been superseded in America by the following arrangement. This ingenious contrivance was gotten up by Mr. Charles T. Smith, an experienced and distinguished telegrapher of America. Mr. Smith having been engaged in manipulating the telegraph in different parts of America, he, at an early day, found it necessary to devise an arrangement to parry off the continual presence of atmospheric electricity, and to that end he invented the paratonnerre represented by fig. 6.

Fig. 6 represents the circular form adopted by Mr. Thomas Hall of Boston. Many lines use the same appliance in an elongated form. The arrangements consist of two brass plates separated by a thin piece of silk or paper. The upper plate is in the line circuit; the wires are attached to one of the brass binding posts; the earth wire is attached to the under plate.

Between the plates are placed two narrow strips of paper. When the lightning strikes the line, it enters the upper brass plate and passes to the under one, and in its passage through the paper it burns many small holes. The plates are about

Fig. 6

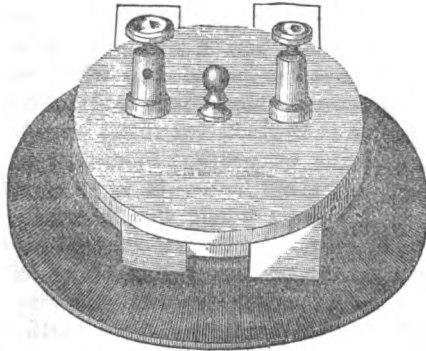

two and a half inches diameter and one sixteenth of an inch thick ; they are fastened to a small board, as seen in the figure, and the board is attached to the wall or to the table in the station. This form of paratonnerre is in universal use on the American lines, and it has proved to be the most perfect in the attainment of the desideratum.

#### ATTACHMENT OF PARATONNERRES AT RIVER CROSSINGS.

A similar arrangement as the above has been placed on each side of river crossings, to preserve the cables from destruction by lightning. I have had several cables destroyed by lightning. On one occasion, the line wire was struck by lightning about a mile distant from the cable. Several of the poles were torn to pieces. The current passed on to the cable, and then from the conducting wire to the water, cutting a longitudinal incision through the gutta-percha some ten feet long, as clear as if done with a razor. At another time, I found the gutta-percha very much swelled, rough and porous ; and at another time, the gutta-percha was pierced with countless numbers of openings like pin-holes.

On an examination of a cable that had been worked during the whole summer, but had finally failed, I found the coating of gutta-percha destroyed as to its capacity for insulation. The inner coating was parched dry and easily broke ; the second and third coverings were also brittle, and on bending the cable the gutta-percha would break. A few feet of the

cable was thus injured, and the remainder was found to be perfect.

In the above cases the lightning produced different results, though all were fatal to the working of the line. Too much pains cannot be taken by the telegrapher to protect the river crossings, whether over masts or through submarine cables. The destruction of the conductor in either case occasions serious losses to the lines and a very great inconvenience to the public. It cannot be denied but what many cases of injury to the apparatus in the offices and to many crossings are justly chargeable to neglect, but many have been the result of incompetency of the telegrapher in charge of that special department. On the other hand, it is to be admitted that many have been the cases where the ingenuity of man has failed to devise the proper protection in the premises. That mysterious agent manifests itself sometimes in such power that no contrivance known in the arts can stay its wild and fearful flight between the heavens and the earth.

#### INCIDENTS OF LIGHTNING STRIKING THE LINE.

In 1850, I witnessed a very remarkable incident that took place at St. Louis. The telegraph wire crossed over the Mississippi river from a mast some 185 feet high placed on Bloody Island. On the city side, a shot tower some 180 feet high from the water was used. Dark and heavy clouds mantled the whole heavens, and the storm seemed to be near the telegraph line; the wind was powerful, and my attention was directed to the line, fearing the mast would yield to the storm. In an instant the wire between the mast and the shot tower was struck, and simultaneously elongated drops of blue flame fell to the water. The scene was sublime; the deed was done. Providence, through his mysterious ways, in less time than the twinkling of the eye, dealt a lamentable blow upon the telegraph. A station was speedily established on the opposite side of the river; a ferry was used, and a messenger carried the dispatches from the city to the opposite station.

In the same year, while at a small village, about twelve o'clock at night, I happened to be looking out of the window, watching an approaching storm. Darkness was complete. A ball of fire fell from the heavens and struck the wire. Around the edges of the rotund flame there appeared a blue ring; in an instant the ball divided and spread to the right and to the left. Next morning the apparatus at the station was badly injured; the relay magnet was burnt, and the cores of the spools or bobbins were much fused. About three feet of the

ribbon paper was burnt. The fire stopped at the rollers of the apparatus; no other injury was done. The station was about one fourth of a mile from the place where the ball fell upon

Fig. 7.

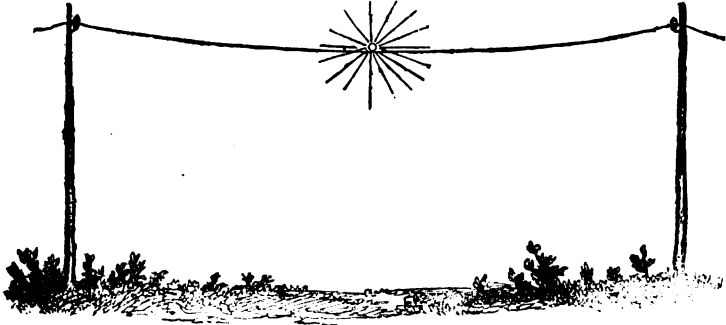

the wire. Whether or not the ball lightning did the injury in the station I am unable to say, but I presume it did. The end of the earth wire was a little burnt; the wires in the station were properly adjusted for the night.

## STEINHEIL'S PARATONNERRE.

In 1846 Dr. Steinheil constructed the following arrangement for the Austro-Germanic telegraph lines.

Fig. 8.

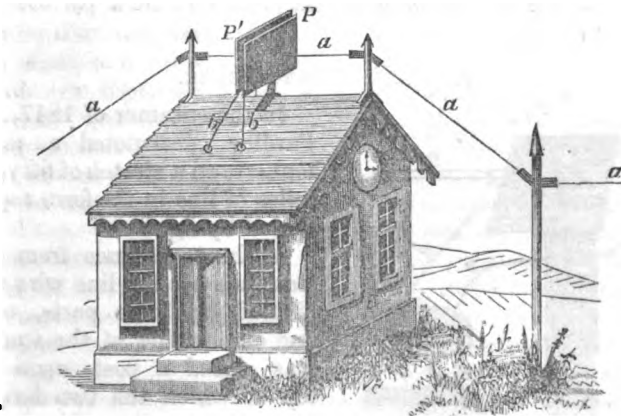

The wire *a a* passes over the station house in which the telegraph instruments are placed, as seen in the figure. On



top of the house is fastened an arrangement consisting of two copper plates  $P$   $P'$ , to each of which the wire is attached; the wire on the right being fastened to the middle of the right-hand plate, and the wire on the other side fastened to the left-hand plate. These copper plates are about six inches in diameter, and between them is laid a thin piece of silk cloth, so adjusted that there can be no metallic connection between them. They are held in a vertical position, as seen in the figure on the roof of the station-house, by means of insulated supports, and they are protected from the weather by means of a small roof covering not placed in the figure.

By this means the large metallic circuit is interrupted or made incomplete, the silk between the plates serving as a non-conductor. From the brass plate  $P$ , the line wire  $b$  is extended down to the telegraph apparatus, and after traversing the coils or bobbins, it returns at  $b'$ , and is fastened to the plate  $P'$ . When the line is charged, the voltaic current passes over the wire to the plate  $P$ ; thence over  $b$  to the apparatus; thence over  $b'$  to plate  $P'$ ; and thence over the line to the next station. Atmospheric electricity will not pursue the same course. It will not follow the wires  $b$   $b'$  except in a very small quantity. It passes from one plate to the other, traversing the silk cloth, and then it follows the wire until it becomes dissipated through proximate conductors to the earth.

The atmospheric electricity that passes over the wires  $b$   $b'$  and through the apparatus is but little, and can do no damage. I was informed at many of the telegraph stations in Germany that this form of paratonnerre has proved to be a perfect protection to the apparatus.

#### FARDLEY'S PARATONNERRE.

Fig. 9.

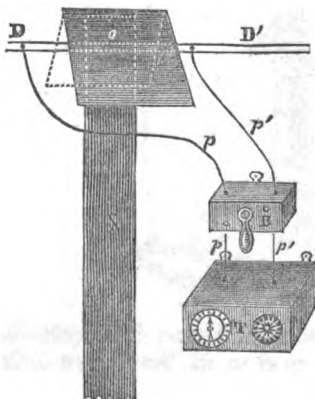

In the summer of 1847, Mr. Fardley constructed a paratonnerre on a stretch of fifty-six miles of line in the form represented by fig. 9.

A short distance from the station-house the line wire was divided into two parts,  $D$   $D'$ , and on one side of the station was placed a post, upon the top of which the two divided ends of the line wire were brought within one fiftieth of an inch of each other. This place of separation was covered

with a small roof. On each side of the post were two small copper wires  $p p'$ , about twenty feet long, which connected the line wire with the apparatus  $\tau$  in the station-house. By this arrangement the lightning charge traversing the line overleaped the small separation at  $o$ , and passed beyond the station, and did not go over the longer route through the apparatus. During the most severe storms, no further injury was done at the stations than the burning of the small wires  $p p, p' p'$ . When a plus charge traverses  $p$ , it enters apparatus  $B$ , inside of the telegraph station, which, when thus charged, serves to detach the receiving apparatus  $\tau$ .

MEISNER'S PARATONNERRE.

On the 5th of May, 1846, Mr. Meisner, of Germany, was noticing the telegraph wires, and he saw the electricity leap from the line to the earth wire in the station, burning the fine wire of the magnet coils. This circumstance led him to construct an arrangement in all the stations of the ducal Brunswick state telegraph, for the purpose of protecting the operators and the apparatuses. Figure 10 represents one of them.

Fig. 10.

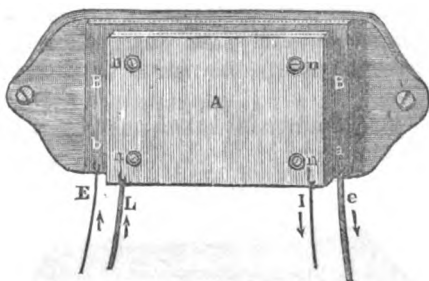

The naked wire of the line is insulated on the poles by porcelain, shaped as bells, and it enters the ground near each station. It is insulated with gutta-percha, and drawn through tubes of lead or iron. This subterranean section,  $L$ , is conducted through the foundation of the house, and thence to the telegraph room, where it is fastened to

the copper plate  $A$ , which is eight inches long, four wide, and one eighth of an inch thick. From this copper plate  $A$  proceeds a fine insulated wire,  $l$ , to the telegraph apparatus through the voltaic battery, and thence through the wire  $E$ , traversing the copper plate  $B B$ , and then with the wire  $e$  to the earth, or onward toward the next station. Fig. 11 is a sectional view of both plates as screwed to the common base;

Fig. 11.



the copper plate  $A$ , which is eight inches long, four wide, and one eighth of an inch thick. From this copper plate  $A$  proceeds a fine insulated wire,  $l$ , to the telegraph apparatus through the voltaic battery, and thence through the wire  $E$ , traversing the copper plate  $B B$ , and then with the wire  $e$  to the earth, or onward toward the next station. Fig. 11 is a sectional view of both plates as screwed to the common base;

each is insulated from the other. The screws  $n\ n\ n\ n$ , passing through their respective holes, are insulated with silk, ivory or some other non-conductor; this arrangement is fastened to the apparatus table or to the wall, with screws, as represented at each end of the figures. The two insulated fine wires,  $l$  and  $e$ , are insulated from each other, and connect with the apparatus through the ordinary binding screws. The voltaic current traverses the whole route of the wires, but the lightning current enters plate  $A$  and leaps to plate  $B$ , and thence to the earth, or on to the next station, until dissipated in the air. The plates  $A$  and  $B$  were fastened near together, but did not touch. Voltaic electricity must have a metallic conductor, consummating a continuous and complete circuit. The smallest break in the conductor will arrest the flow of the current and its generation by the battery organization. Not so with atmospheric or static electricity; it traverses a conductor until it reaches the spot where it can pass off into the earth; it leaps from one conductor to another, from plate  $A$  to plate  $B$ . There are no known laws demonstrating the limit as to distance the atmospheric current will leap. A tri-cuspidated charge will be more energetic and will pass over a greater space to reach the earth than the ordinary heat lightning flash.

Mr. Meisner invented another contrivance for the arresting of atmospheric electricity. Fig. 12 represents the arrangement

Fig. 12.

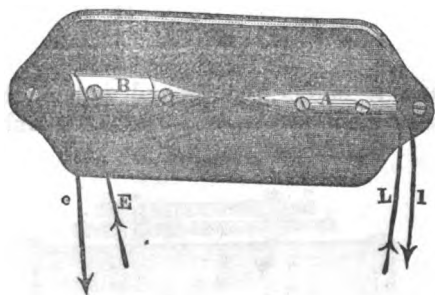

as placed on the line from the Bruuswick station to Vechelde. The line wire  $L$  entered the station and was fastened to the copper bar  $A$ , and from the bar by  $l$  to the apparatus, and then through  $e$  to copper bar  $B$ , and by  $e$  to the earth, or on to the line wire beyond the station. The bars  $A$  and  $B$  are fastened to a wooden base and separated at their points by a very small space. The voltaic current traverses the wires, but the lightning passes from the point of  $A$  to the point of  $B$ , and thence to the earth, or on to the station beyond.

The reader will observe that the contrivances, figs. 6, 8, 10, and 12, are different one from the other, but at the same time

the philosophy of each is the same. The American paratonnerre, fig. 6, passes the current immediately to the earth; Steinheil's carries it on to the next station, though it is certain to be dissipated from the wire within a few miles, and perhaps none of the plus charge will ever reach the next station in course. Mr. Meisner made the base of his contrivance a part of his circuit to the earth or of the line. The American improvement on Steinheil's plan, fig. 8, would lead the wire *a a* *b* to the apparatus, and thence to the earth, or on to the next station, but not by way of plate *r'*. From plate *r'* the American plan is to conduct a wire immediately to the earth, and no other wire would be connected with plate *r'*. The same remarks may be applied to the arrangements invented by Mr. Meisner. In the use of fig. 10, arranged as above described, the American telegrapher attaches the line wire *L* to plate *A*, and by *l* through the apparatus, and then it is extended on to the next station. An earth wire is fastened to plate *B*; this completes the arrangement, as represented by fig. 6. In this combination the voltaic current traverses the line wire, through the magnet coils, and thence on to the next station or to the earth, as desired by the telegrapher. The lightning will not pass through the fine wire of the magnet, but will leap from plate *A* to plate *B*. If the line is extended through the office to the next station, a paratonnerre will have to be placed for the line on each side of the apparatus in the station.

## NOTTEBOHN'S PARATONNERRE.

The director-general, Nottebohn, of the Prussian government lines, devised a novel combination for a paratonnerre. Fig. 13 represents the arrangement employed in the stations of the Prussian telegraphs.

Between the two pointed copper or brass cones, *u q*, is a

Fig. 13.

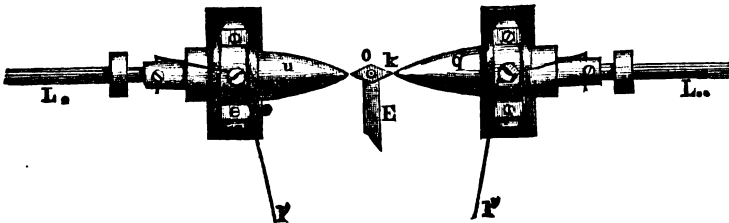

double pointed copper marked *o k*, with its points nearly touching the points of *u* and *q*. The copper piece *o k* is con-

nected with the earth by means of the large copper rod or wire *e*. The pointed cones *u* *q* connect respectively with the line wires *L* . and *L* . . and with the wires *l'* *l''*, which lead to the apparatus. The voltaic current from the distant station enters, for example, through the wire *L* . of cone *u*, thence by the wire *l'* to the apparatus, and thence through *l''* to the cone *q* and line wire *L* . . On the other hand, the current may come from line *L* . . and traverse the metallic circuit composed of *q* *l''*, the apparatus *l* *u* and *L* . The voltaic electricity follows the metallic circuit, but the lightning seeks its course to the earth through the diamond-shaped copper *o k*. This combination, in principle is the same as fig. 6, employed on the American lines. I am unable to say which of the two are the best for the purposes. On the American lines, the flat plates are found to be perfect in the protection of the telegraph apparatuses. Mr. Nottebohn informed me that the above device answered fully the objects in view, and that he had never known of its failing to successfully preserve the instruments of a station. The flash from cone to cone was observed on many occasions when, at the locality, there was not a cloud to be seen.

#### BREGUET'S PARATONNERRE.

On the French telegraph lines a different mechanism is used for the preservation of the apparatuses of the stations. At an early day in the history of French telegraphy, the distin-

Fig. 14.

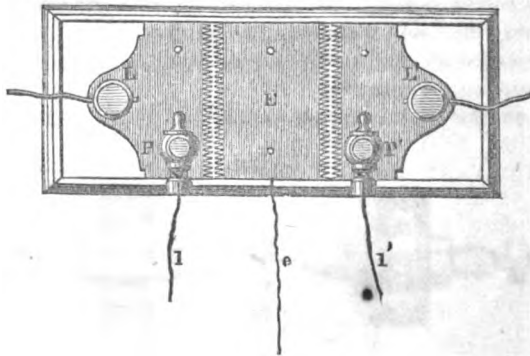

guished Breguet invented an arrangement represented by fig. 14. This paratonnerre is composed of copper or brass plates, *L* *E* and *L'*, with edges like saw teeth, as seen in the figure. The line wires are fastened at *L* *L'*. Between the plates *L* *L'*

another plate *E*, with saw-teeth, fastened so that the teeth of the two former almost touch the teeth of plate *E*. From *P P'* the wires *l l'* run and connect with the telegraph apparatus. The wires *l l'* are connected to the plates *L L'* by means of the binding posts *P P'*. The middle plate *E* is connected with the earth by a large copper wire *e*. The voltaic current follows the metallic circuit *L' l*, the apparatus *l* and *L*, or *vice versa*. The atmospheric electricity escapes through the plate *E* and wire *e* to the earth.

## THE FRENCH PARATONNERRES.

Fig. 15 represents a form used on the French railway lines. It is composed of a small wooden plate *M N*, upon which are placed binding screws, *B* and *C*, from two and a half to three inches apart. A very fine iron or platina wire, fixed at its two extremities in two copper posts, and placed in a glass tube, connects these two binding screws or posts.

The upper part *B* communicates with the line *A*; the lower part *C* communicates with the wire of the station *D*. The current coming from the line must traverse the fine wire *B C*, so that if the electric discharge is strong enough, this wire will melt and interrupt the communication between the line and the apparatus.

In front of the upper binding screw *B* is a metallic piece, *E*, communicating with the earth. Copper points placed in front permit the electricity accumulated on the line wire to pass into the earth whenever the small wire is burnt.

It sometimes happens that the wire contained in the glass tube is volatilized by the effect of the discharge, and is precipitated against the tube so as to form a sort of conducting lining. The glass tube, however, is frequently dispensed with, as the sole object of its use is to protect the wire which it contains. When the wire is melted by the electric discharge, it must be replaced in order to re-establish electric communication. The French are of the opinion that these paratonnerres should be placed as much as possible outside the station-houses, in order that the line may be completely separated from the

Fig. 15.

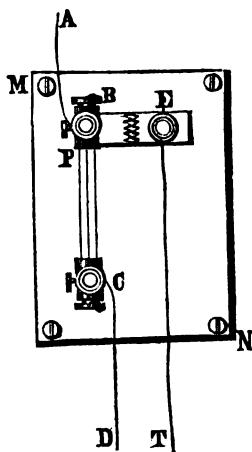

interior of the station house after the fusion of the small platina wire.

Fig. 16 represents a different form, and is considered more advantageous, particularly in making the line wire communicate with the earth when the fine wire has been broken. This paratonnerre consists of a rod *M N*, formed in three parts of copper, *A C*, *D G* and *H B*. The extreme parts *A C* and *H B* are separated by ivory disks, *C H* and *C D*, from the middle one, which bears a bulge part *E F*. A very fine silk covered wire is fixed on one side to the upper part *M*, which unscrews, and the other part is fastened to a little screw at the lower extremity *N*. This wire is coiled around the rod. The extreme portions of the rod, *B H* and *A C*, are in communication only by means of this covered wire. The middle part does not communicate with the two others except when the silk covering of the wire is removed. The rod traverses three globular supports, *P*, *R*, and *Q*. By means of screws the contact of these supports with the three portions *A C*, *E F*, and *H B* is secured.

Fig. 16.

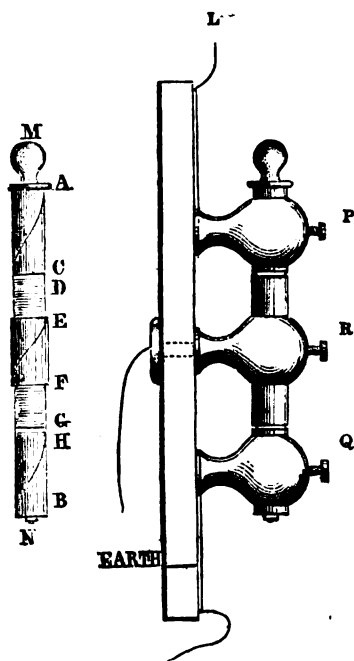

The first support, *P*, communicates with the wire of the line *L*; the second, *R*, with the earth; and the third, *Q*, with the wire of the apparatus.

When an atmospheric discharge melts the fine wire, or merely burns off its silk covering, a communication is established between the line and the earth. When this fusion has taken place, the rod is either replaced by another in readiness, or else another silk covered wire is coiled around it. The condition of these rods may always be known by noticing whether the current passes between the two extreme portions, and not between one of them and the middle.

A front view of this form of paratonnerre is represented in fig. 17. The line wire is attached to the button *L*. At *U* is a

communicator which puts in communication this wire either with the strip  $n$ , or with the strip  $x y z$ , or finally with the copper plate  $w$ , which is in communication with the earth wire.

In the first case, the current of the line must traverse the wire of the paratonnerre; in the second, it goes directly to the apparatus; and, in the third, it goes to the earth.

Whenever the weather is stormy, this latter communication ought always to be established. The plates  $w$  and  $L$  are furnished with points, the use of which is the same as that of the paratonnerre hereinbefore described. When there is a prospect of a storm, the spring of the commutator  $v$  should be placed upon the strip  $x y$ , but if the silk covered wire surrounding the rod  $m n$  is laid bare at certain points, the current, instead of traversing the wire of the apparatus, which offers a great resistance, goes directly to the earth by means of the support  $r$ . In order to prevent all communication between the plate  $x y z$  and the earth, the rod must be removed.

Attempts have been made in France to avoid this inconvenience, by giving to the paratonnerre the following form, which has been recently adopted on some of the lines (fig. 18).

This apparatus consists of a little vertical column, at the base of which are attached three little copper binding screws. At  $t$ , the wire of the earth is connected; at  $L$ , the line wire; and at  $A$ , the wire of the telegraph apparatus.

The binding screw  $L$  communicates with the axis  $h$  of a three-pronged commutator, which can be moved by means of the lever or arm  $k$ . The plate  $A$  represents "*with paratonnerre*,"  $B$  represents "*earth*," and  $C$  represents "*without paratonnerre*."

Fig. 17.

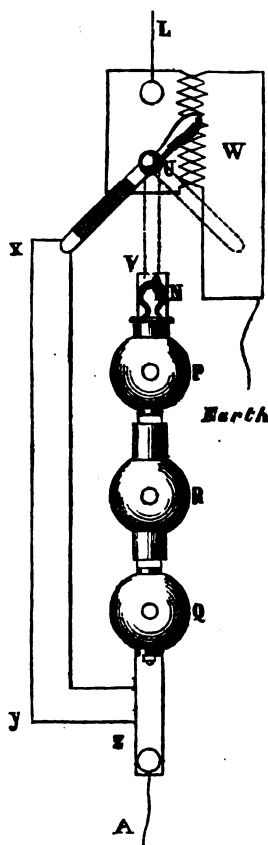



The branches of the commutator may press upon little metallic plates, *a b c d*. The axis of the commutator communicates only with the middle branch; the two others are formed of a single piece, and are insulated by an ivory disk.

Fig. 18.

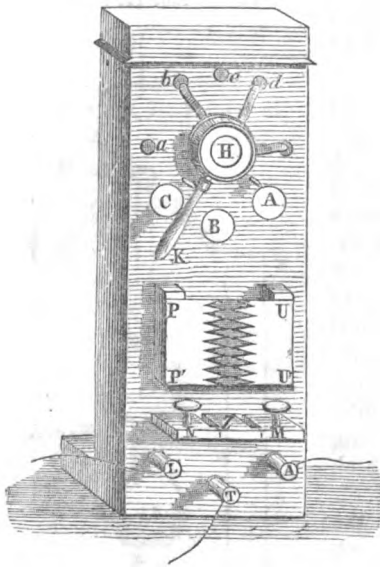

The fine silk covered wire is placed in the interior of the little metallic case *z*. The extremities of the silk covered wire being laid bare, are fastened by screws in the two other little pieces *m* and *n*.

The following communications are established by means of wires or metallic straps fastened behind the plate. *L* with *P P'* and *H*; *a* with *n*; *b* with *m*; *d* with the lever *A*; *c* with *U U'*; and *z* with *r*.

1st. When the rod *r* of the paratonnerre is over the letter *c*, representing "*without paratonnerre*," the middle branch of the commutator presses upon

the plate *d*, as represented by the figure. The current coming from the line to the button *L*, traverses the copper plate furnished with points *P P'*, and passes from the centre, *H*, of the commutator to the button *d*, whence it goes to the screw post *a*, and to the apparatus.

2d. If the rod *k* is placed above the letter *A*, representing "*with paratonnerre*," the three branches of the commutator will be upon the three plates, *a*, *b*, and *d*. The current, after having traversed the plates *P P'*, arrives by means of the middle branch to the point *b* and to the copper piece *m*. It traverses the wire of the paratonnerre at *z*, proceeds from *n* to the button *a*, follows the two extreme branches of the commutator, and passes from *a* to the screw below, lettered *A*. If an electric discharge melts the little wire, the line becomes in communication with the earth by means of the copper piece *z*, in which the little wire is placed.

3d. In the third position of the rod *k*, the middle branch presses upon the plate *c*, which communicates with the earth

by means of the rod  $u$   $u'$ , the plate  $z$ , and the binding screw  $t$ .

## WALKER'S PARATONNERRE.

In writing upon the subject of atmospheric electricity in relation to its interference with the operation of the electric telegraph, Mr. Charles V. Walker, one of the most distinguished telegraph electricians in England, says :

"It is a well-known property of ordinary charges of electricity to expand, so to speak, and to occupy the outside surface of conducting bodies. If an ice-pail or metal vessel be insulated on glass legs, and a brass ball hanging to a silk thread, be employed to carry a charge of electricity from a common electrical machine to the *inside* of the vessel, it will part with *all* its charge the moment the two metals touch ; and, on now applying a test instrument to the inside of the ice-pail, no electricity can be found there ; the charge appears to have vanished. But, on presenting it to the *outside*, the charge is discovered there in its full quantity. I thence considered that, whatever arrangement I should insert in the course of the conducting wire, I might very advantageously place this arrangement *inside a stout metal cylinder*, in good communication with the earth ; so that the charge, in that part of its course should be in all but contact with the earth connection, and further facilitated in its escape by having the latter on its *outside*.

Fig. 19 represents the lightning conductor very nearly in full size.  $A$  is a brass cylinder, one sixteenth of an inch thick (shown in section in the figure), in perfect metallic communication with the earth by the stout wire  $E$ , and insulated from the conducting wire by a disk of boxwood  $a$ , and a boxwood bobbin  $b$   $b$ . The arrows show the direction of the charge from the line wire  $c$  to the telegraph, to which it is screwed by the end  $d$ . The ends of the bobbin closely fit the inner surface of the cylinder ; but it is slightly grooved in its course to receive two or three layers of a silk covered copper wire  $g$ , finer than any elsewhere to be found in the instrument ; the wire is in the circuit, commencing at the thick brass wire  $e$ , and terminating below at  $d$ , and is in very close proximity to the earth,

Fig. 19

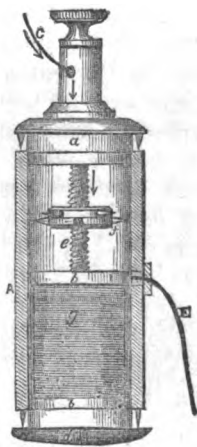

—closer, in fact, than any other wire or piece of metal inside the instrument or the office. The wire *e* is further furnished with two nuts, *f*, fitted with points, made by gauge to approach almost within hairsbreadth of the cylinder. The boxwood terminations *a* and *d* are also capped with brass disks; from the upper disk, points approach the earth-cylinder; and from the lower end of the earth-cylinder, points are presented to the disk. The object of the coil *g*, of very fine wire, is, that, from its tenuity and from its juxtaposition to the earth-cylinder, it shall have a better chance of being burned, in an extreme case, than either the wire of the bell coil or that of the needle coil. The use of the points does not require any explanation.

The first set of these conductors were placed at Tunbridge Wells station; and not many weeks had elapsed before a lightning flash entered the station, and it behaved with the apparatus as I had been led to expect. It passed safely through the stout wire *E*, and immediately on arriving at the fine wire *g*, it darted off to the cylinder, and, by its explosion, singed the silk and exposed the wire where I have placed a black spot, near *A*. In this case the flash was moderate, and the wire was not burned.

It went a step further, and another of its features was called into requisition, on 8th August, 1849. During the night a violent thunder-storm occurred, the effects of which were especially manifested on the Ashford end of the Ramsgate branch. Three poles, unprotected by lightning-wires, were splintered at Chartham, about two miles beyond Chilham; and the lightning entered both Chilham and Ashford stations, and, by its snappings and explosions, very much alarmed all on duty. When all was over, it was found that at Chilham, where there were no lightning conductors, the wire of the bell-coil was burnt, and of both the electrometer coils, and other severe explosions occurred about the apparatus: one of the No. 16 size copper wires was burnt and broken. At Ashford there were lightning-conductors on the two instrument wires, but not on the bell-wire (a few days previously the bell-coil had been saved by the lightning-conductor being burned; the latter was brought away to be examined, and had not been replaced). It was now found that the Ashford electrometer coils, both of which had conductors, were saved; the fine wire, *g*, of the lightning conductor being burnt by the explosion in both cases, but the bell-coil, which was unprotected, was visited by the discharge and burned.

Lightning flashes occasionally disturb the polarity of the

needles, and even demagnetize them. This is much more the case with the rhomboidal and the short needles than it is with the long ones; and the former have been found demagnetized even while furnished with these protectors; but in the storm above-mentioned, while the magnetism of the unprotected needles at the Canterbury station was disturbed, that of the protected needles at Ashford was undisturbed. I have sometimes been half induced to think whether the intense and momentary atmospheric charge may not act so violently and irresistibly on the *magnetism* in the needle, that it deflects it more rapidly than the *metal* can follow, and that the conflict thus caused by the *vis inertiae* of the metal may overthrow the magnetic arrangement of the particles of steel. In like manner, it may be conceived that the loss of magnetism occurring in the ordinary use of the instrument may be mainly due to the incessant jars the needles receive as they strike against the stops by which their beats are limited."

It has often happened on the American telegraph lines that the lightning has entered the station, and burnt much of the wire surrounding the electro-magnets. I have frequently seen the iron cores partially fused, and the brass parts melted at their corners. Such accidents were of frequent occurrence in the earlier days of telegraphing. Then we did not have the beautiful contrivances practically and successfully applied at the present day. It was often the case, too, that the electro-magnet cores were permanently magnetized, which occasioned much difficulty in the reception of messages. On the English lines the needles suspended in the spools require to be permanently magnetized, and the atmospheric electricity has frequently demagnetized them. On the American lines the iron cores of the magnets require to be free from all permanent magnetism, and the lightning has on many an occasion permanently magnetized them. We are, however, making rapid strides in the comprehension of this strange and mysterious phenomenon.

The telegraph lines in southern latitudes are much interrupted by atmospheric electricity in ordinary quantities. Some of the lines have two wires, one above the other. When the wires are thus arranged, the atmospheric electricity will principally charge the upper wire. This I discovered at a river crossing some years ago; I had placed over the masts two wires, one above the other. The upper wire was nearly always more or less charged, and the under wire seldom charged. Where a line has two wires upon it, one above the other, it will be found best to make the under one the through

or long circuit wire, and the upper one the short circuit or local wire. When thus operated, the plus electricity of one section of the country will not disturb the circuit in another. The local dispatches can be forced through with batteries of greater quantity current on the short circuits; and, besides, the local line circuits can be divided without interrupting the transmission of dispatches between places far distant from each other. In warm climates, electricity seems to exist in large quantities in the air, and it is this kind of electricity that retards the transmission on the wires. The flash of a storm is over in a moment, but the other seems to be sluggish and stationary, until conducted to the earth by the rain or the dews.

For the information of practical telegraphers not conversant with the subject-matter herein discussed, I will add a few instructions in regard to the restoration of the electro-magnet, when permanently magnetized by heavy charges of atmospheric electricity. Suppose, for example, the line extends from A to B, with the batteries on the line directed in their organization from the former to the latter station. The voltaic current traverses, first the right-hand spool, and then the left-hand spool of the electro-magnet. The above represents the normal positions of the batteries and the electro-magnets. In case the cores of the magnets become permanently charged with magnetism, it is important and indispensably necessary to expel it from the cores immediately, as the art of telegraphing solely depends upon the instantaneous magnetizing and demagnetizing of the electro-magnets by the opening and closing of circuits, and thus putting on or taking off the voltaic current of the batteries on the line. To restore the cores to their original condition, it is necessary to reverse the course of the electric current through the spools, so that it will pass first, through the left-hand coil, and then through the right-hand spool. To accomplish the end more rapidly, a current of quantity electricity may be passed through the spools for a few hours, traversing the magnets from left to right. If the iron cores are moveable from the coils, as many of the magnets are now manufactured, it will be better to heat them to a slight red, and then allow them to cool slowly. This process will expel the permanent magnetism, and restore the iron to its original susceptibility of magnetic action.

If the telegrapher will carefully study the details and illustrations in this chapter, he cannot fail to be fully equal to any emergency of his station, so far as pertains to the wild and restless lightning, let it come with whatever power it may from any zone that girdles the earth's surface.

# SUBTERRANEAN TELEGRAPHS.

## CHAPTER XLI.

Subterranean Lines in America, Prussia, Russia, Denmark, and France—Lines in Great Britain—Underground Lines in Hindostan—Mode of Testing Subterranean Telegraphs—Repairing the Insulated Wires.

### SUBTERRANEAN LINES IN AMERICA, PRUSSIA, RUSSIA, DENMARK, AND FRANCE.

IN America we have had comparatively little experience in subterranean telegraphy. That which we have had has been confined to short distances, not exceeding one or two miles, and then in connection with air lines. We cannot, therefore, give any information from the practical experience of American telegraphy. The experimental line authorized by the Congress of the United States was attempted to be laid in lead pipes. The line was laid in the earth nine miles from Baltimore, and it proved a failure. The wires were No. 16 copper, covered with cotton and shellac, drawn through the lead pipes. When the underground process was abandoned, the wires were pulled out and placed on poles, and the line was thus completed in the month of May, 1844, under the direction of Prof. Morse.

In Europe there have been constructed many subterranean lines, some of which have proved eminently successful, and others total and costly failures.

Prussia was among the foremost to lay down subterranean telegraph wires. They were insulated with gutta-percha and covered with a leaden pipe, fitting close thereto. These wires were buried in the earth about twenty inches or two feet deep. After they had been laid a few years, much difficulty was experienced in working them, and repairs became necessary continually. The interruptions following this necessity for continual examination of the buried wires became annoying and very expensive. The government had all the telegraphs placed upon poles, abandoning the subterranean lines.

While at Berlin, in 1854, through the kindness of the administration of the telegraphs, I was present at the examination of the subterranean wires then being substituted by the pole lines. These wires had been laid under the gutters along the curbstones of the sidewalks. The leaden covering or pipe had been in several places eaten away by the acids of the earth, originating, no doubt, from the slops conducted from the houses into the streets. The gutta-percha insulation had been destroyed, and on bending it would fall to pieces, leaving the copper conducting wire exposed. It was the opinion of those in authority that the gutta-percha had been improperly manufactured, and that the leaden covering had not been placed around it with sufficient care to give the necessary protection.

About the same time Russia established a subterranean line of two wires from St. Petersburg to Moscow, along the railway. Like the Prussian lines, they failed from time to time, and the government was compelled to abandon the underground wires and erect another on poles. The effect on the subterranean wires was found to be the same as was discovered in Prussia. Besides, the retardation of the electric current was sensibly felt between St. Petersburg and Moscow, a distance of some four hundred miles.

In the city of St. Petersburg and for the telegraph to Cronstadt, some twenty miles long, the wires are laid in the earth, with extraordinary care and protection from the salines of the earth. During my visits to Russia in 1854-'57, I never heard of any complaint against the working of the lines laid through the cities.

In Denmark the first lines were laid in the same manner precisely as the Prussian lines, and like results were experienced there. In 1854, the line across the island of Zealand, from Copenhagen to Corsor, was placed upon poles. It was during my visit to Copenhagen, in the summer of 1854, that I observed the retardation of the voltaic current on underground lines, which had been made known by Prof. Faraday. There were, therefore, two obstacles in the way of successfully working the subterranean lines, namely, the non-insulation of the wires and the retardation of the electric current when being transmitted from station to station, the philosophy of which is considered elsewhere in this book.

In Paris, the subterranean lines insulated with gutta-percha and lead were at an early day abandoned. By authorization of the Emperor, I was permitted, in 1854, to examine the details of the telegraphs in France, and I was informed that the subterranean lines had been unsuccessful. Subsequently, and

in 1857, I witnessed the laying of some subterranean wires along the Champs Elysees. Trenches were dug about four feet deep and about three feet wide. At the bottom a small trench about twelve inches wide and ten inches deep was dug, for the wires to be placed. There were about thirty wires drawn taut, some two inches apart, along and in this smaller trench, sustained by boards temporarily, and until the trench was filled with asphalt and very dry gravel, as adopted in Hindostan, and hereinafter explained. This gave a solid mass of composition around the wires. I have been informed that the wires proved to be perfectly insulated. They were covered with cotton and shellac. The process was expensive, and it yet remains an experiment.

## SUBTERRANEAN LINES IN GREAT BRITAIN.

In Great Britain a very large number of lines have been laid underground, the greatest extent of which has been by the Magnetic Telegraph Company. These subterranean lines extend over England, Scotland and Ireland, and they work with an efficiency and durability fully commensurate with the expectations of the company

Fig. 1.

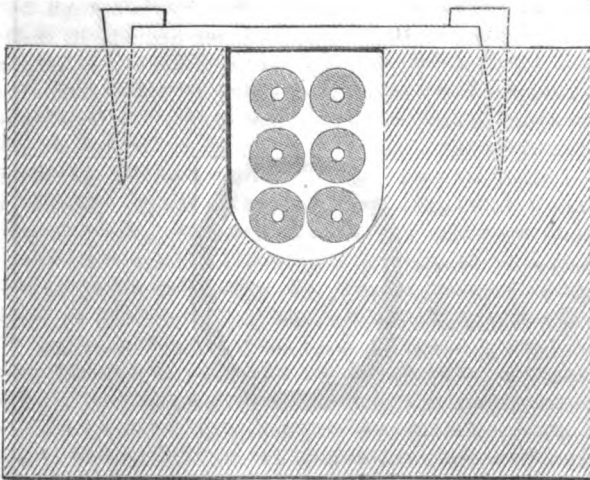

Upon the lines of this company magneto-electricity, described elsewhere in this work, is employed. Some telegraphers are of the opinion that this species of electricity is more serviceable on underground lines than that which is generated by the ordinary chemical voltaic batteries.

In a communication from the now Sir Charles T. Bright,



the engineer of the above-named company, and under whose direction a very large range of subterranean lines have been constructed, I have been informed that the chief part of the underground lines laid by him have been in troughs of kreosoted Baltic timber, with a lid of galvanized roof iron, overlapping the groove by half an inch on each side of the gauge No. 14 in thickness.

It is drawn with six wires, but in some places ten are laid.

The line from Manchester to London, the first laid, has a wooden lid instead of the iron lid afterward introduced. The district is easy of access by railway the entire distance, and the roads well attended to by the road surveyors (county, not *telegraph* officers), who inform the company of any work, &c., to be done on the line of the wires.

The wires on this line, ten in number, are covered with a serving of tarred jute as an additional protection, especially while laying, the expense being nearly covered by the saving in labor and carriage, in having the wires all together in a rope, and wound on the same drum.

A full size section is given at fig. 2. The two plans are

Fig. 2.

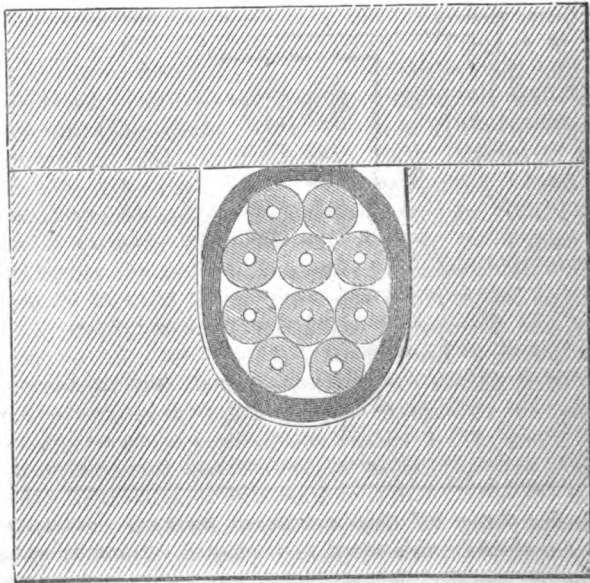

under the ordinary high road; but through the paved streets of towns, where the roads are often opened for laying gas and

water pipes, drains, &c., and where, from the nature of the ground, the full depth of the trench cannot be made, the wires are laid in cast-iron pipes.

The proportion of street work is generally about three miles out of every hundred, but on some lines considerably more. Between London and Manchester there are twenty-one and a half miles laid in iron pipes out of two hundred.

Street wires used to be drawn through solid gas piping of about three inches diameter, the pipes being laid first, and the insulated wires drawn through afterward. In doing this the insulating material was frequently injured; sometimes the wires were broken inside the gutta-percha, or other insulating material, by the force necessary to pull them through, and occasionally they were drawn so tight that, on the slight settlement of the ground, usual after the line has been laid a short time, some of the wires broke inside the insulating material, occasioning great difficulty and expense in detecting the fault.

The great proportion of the faults, however, were only abrasions of the insulating material; and though at the time the wires passed with all appearance of perfection through the ordeal of testing, and the streets were closed, and the pavement reinstated, before long the defects became so manifest as to interfere with the working of the apparatus, and the streets had to be re-opened, and the wires tested through, length by length, for the fault.

The wires required jointing at every other drawing point, and these points frequently proved defective, particularly in the old varnished-cotton method of insulation and others, prior to the use of gutta-percha.

"In 1852," says Mr. Bright, "having considerable lengths of street work to lay, I gave a good deal of attention to the subject, and determined on having the pipes cast longitudinally in two pieces, so that the wires could be *laid in* the under lengths, and the upper lengths then attached, instead of drawing, or threading them through solid pipes. I was the better able to carry this out through the introduction of gutta-percha, rendering the exclusion of moisture for the interior of the pipes of less moment. I tried various forms, rectangular, half-rectangular, with an arched lid, semi-cylindrical, with a flat sole, &c., but the form I found most generally useful and convenient, was that having the upper and under half exactly similar, making together a round pipe. I have the pipes cast in six-foot lengths, and about two inches internal diameter, the substance being three eighths of an inch; the sides fitting together without any flange, but fixed by small bolt and nut fastenings

through semi-circular lugs projecting about one and a half inches from the side; one pair of lugs being about nine inches from the faucet, and another pair two feet from the spigot end.

A pipe of these dimensions is cheaper than the old three-inch solid pipe, and more generally useful, the halves being convenient for fixing to walls, viaducts, &c., over wires needing good protection in such places; and, from its circular form and smallness, it is very difficult to break, as a pick-axe, or other tool, cannot easily strike it full.

The process of laying in the wires is rendered much more expeditious and economical by the use of half pipes. The under halves of the pipes are laid down in the trench, and then a large drum, on which the insulated wires are wrapped, is rolled along over the trench, and the wire is paid off easily and rapidly into its place—the upper parts of the pipes put on afterward, and secured in their places by means of screws through small flanges, left outside for the purpose.

So well has this mode succeeded, that in Liverpool the whole lengths of the streets, from Tithebarn railway station to the office in Exchange-street east, were laid down in a single night (eleven hours), and in Manchester, the line of streets from the railway station in Salford to Ducie-street, by the Manchester Exchange, in twenty-two hours. This was the whole time occupied in opening the trenches, laying down the telegraph wires, and re-laying the pavement.

Mr. Reid has invented an ingenious modification of the half pipe, of the rectangular form, which he has patented, and which we have used. Mr. Henley also has improved on the circular half pipe where it is intended only for subterranean work, which he has also patented; but both of them have top and under lengths differently shaped, and I find my original plan preferable for general purposes. All the telegraph companies have adopted the two-piece pipe in place of the solid round pipe, except the old company. The depth of trench is two feet, but all obstacles, as drains, &c., are passed *under*.

I have had no experience in laying underground wires with single-covered gutta-percha, having, in common with all telegraphic engineers in this country considered the occasional small flaws and air bubbles which occur in single wire, and which are covered and made good by the second coating, a bar to its use, except about stations, &c., where it is not in close contact with the earth, and may be readily examined.

I do not think wire, covered with hemp only, could ever be laid so as to preserve good insulation, equally with that coated properly with gutta-percha.

The wires through the streets of towns used, prior to the introduction of gutta-percha, to be coated with a double serving of cotton, varnished, tarred, and enclosed in a leaden tube, which was passed through cast-iron three-inch piping. The wires were continually getting defective after being laid some little time, and we have only been able to have underground wires of any length in a good state of insulation since the adoption of gutta-percha, and that only within the last five years. Before that, the art of coating wires had not reached its present high state of practice; and in one of its first trials, in the most important lengths of street wires in London, it proved in a few months to be an utter failure.

The cost of laying varies very much according to the hardness of the roads, the price of labor, the season at which the work is done, &c.; for six wires, according to the plan shown in fig. 1, a line along the old mail road varies from £180 to £200. The price of gutta-percha has changed so much as to make estimates very little to be depended on for a long time. For ten wires, according to the plan with wooden lid shown by fig. 2, and covered with hemp, the cost may be set down at about £230 per mile—this is on hard Macadamized roads.

I should never lay less than four wires under ground; the proportionate expense of cutting the trench, and for troughing, &c., being about the same for one as for ten, unless the scarcity of timber be much reduced, the expediency of which I doubt.

Wires laid without some protection cannot be depended on very long, unless in a very favorable country. We have had to relay a line from Manchester to Liverpool, which was originally laid without protection, though sunk to a good depth. A line of two wires laid from Dumfries to Stranraer, in Wigtonshire, by a now defunct company, has never been worked, and never will be.

The depth of the trench is two feet. In towns, and where gas and water pipes, &c., are laid, more according to the level of the mains and service pipes, which we keep under in all cases.

Where the road is rocky we blast out about a foot deep, and lay the wires on iron pipes, packing up the trench with the shale and earth. We have had a great deal of rock crossing Shap Fell; on the road from Liverpool to Carlisle we had a considerable length of solid rock; on the London line about Stoney Stratford, on that from Dumfries to Glasgow, near Abington, and through the Deloin Pass, and a good deal in Ireland.

Our wires are in every case, as yet, laid along the old mail

roads, which have been so carefully made and kept in repair throughout the kingdom for years past; we do not therefore ever pass through *marshes*, as the road would always pass over anything of the sort with a bridge or viaduct. We have no telegraphs in England "across country" without regard to roads. For the same reason, we have no upheaving of the roads from frost; they are all too old and firmly set for any such disturbance. The only danger at all of the sort that I apprehend is the *settling* of the roads in some places in the colliery districts, from seams of coal mines passing under the roads.

Our mail roads always cross by bridges, and our wires are laid over them, frequently close over the parapet, about six inches deep (as the crown of the bridge is generally shallow, to avoid much raise of the level of the road), enclosed in wrought iron solid pipes, about an inch in diameter, by three sixteenths in substance, which are threaded over the wires for the short distance required."

The old Electric Telegraph Company has employed for its subterranean lines, to a considerable extent, glazed earthen pipes of the best stoneware, three inches in diameter. They cost about £60 per mile, and in the opinion of some telegraphers are preferable to the iron pipes. They afford all the mechanical protection required, and are totally indestructible by corroding agents of any kind. Glazed earthenware pipes are also employed on the Hindostan lines, such as figs. 3, 4 and

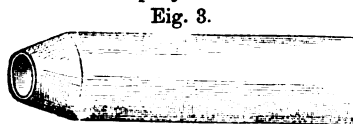

Fig. 3.

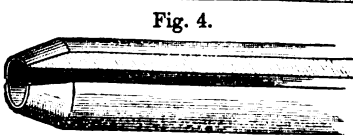

Fig. 4.

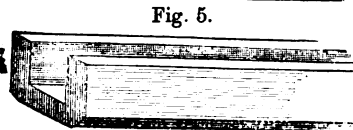

Fig. 5.

5. Like these patterns have been prepared troughs of ordinary brick clay. The rectangular or tubular shape, open at the side, is to be preferred where hydraulic cements are procurable. The closed tubes, or pipes requiring the wire to be drawn through, are not to be used when the other forms can be procured, in the opinion of telegraphers generally. A very simple, cheap and effective protection is afforded by common tiles of the shape shown in figs. 6, 7, and 8. They are grooved along the

Fig. 6.

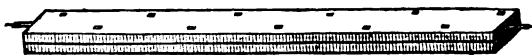

Fig. 7.

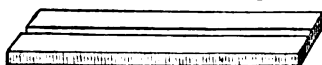
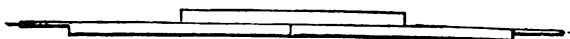

Fig 8.



centre, and applied break-joint fashion. Fig. 6 represents the wire enclosed in the trough. Figs. 7 and 8 show how the pieces are put together. The pieces are laid as represented, and fastened with cement or mortar. The gutta-percha insulated wire should be covered with spun yarn or tape saturated with tar.

Besides the use of earthenware pipe, slate protectors have been suggested.

Wooden troughs, made of good and durable timbers, pickled in sulphate of copper or chloride of zinc solution, have been considerably used.

#### SUBTERRANEAN TELEGRAPHS IN HINDOSTAN.

An underground line of twelve miles has been laid in Hindostan from Calcutta to Bishtapore, in a peculiar manner, and with perfect success. Dr. O'Shaughnessy describes the connecting of this line thus:

“For these twelve miles the line is made of round rod iron, three eighths inch diameter, made up from separate lengths of 13 feet 6 inches each, welded together end to end. This was first done at the iron bridge works at Alipore, so as to form lengths of 200 feet. These, in bundles of ten rods, were carried on men's shoulders along the road, laid end to end, and welded up by a party of native blacksmiths, with a portable forge in charge of a European serjeant. A mile daily was thus done with ease.

The rod being supported on bamboo stakes, three feet above the ground, was next coated with two layers of Madras cloth, saturated with melted pitch, softened with a due admixture of tar, so as to form a flexible coating when cool. These coatings were applied in spiral bands, each  $2\frac{1}{2}$  inches wide, wound round like a surgeon's bandage, and overlapping each other in opposite directions, so as to give four layers of a pliable insulating envelope, quite impervious to water and saline matters, and not liable to decay or to attacks of white ants or vermin of any kind.

This coating was applied by a native *tindal* (boatswain) with twenty *lascars* (sailors), at the rate of 2,000 feet daily.

To protect the rod still further, chiefly from mechanical injury, it was finally laid in a row of thin roofing tiles, of semi-cylindrical form (the *koprile*, of Bengal). These were half filled with a melted mixture of three parts dry sand and one part rosin by weight, and when laid, the whole was filled up with the same melted mixture. When cold, the mass is as hard as brick or sandstone, and perfectly impermeable to water when well prepared.

The sand used for this purpose must be sifted to free it from particles of straw, leaves and sticks; next thoroughly washed, to remove clay and saline matter; thirdly, dried perfectly over a furnace of iron plates, heated by a strong fire. When quite dry and cool it is stored in barrels for use.

The rosin and sand, weighed in separate bags of 10 pounds rosin and 30 pounds sand, are sent on the road and melted in iron bowls (*kuroys*), on temporary fireplaces by the roadside. the mixture is thoroughly incorporated during the melting of the rosin, and poured on the tiles from iron ladles with long handles."

#### MODE OF TESTING SUBTERRANEAN TELEGRAPHS.

Having now explained the different modes of laying a wire underground and insulating it for telegraphic service, I will add a few explanations in regard to the mending of the gutta-percha insulated wires, and the testing of the line to discover faults in the conductors.

Fig. 9.

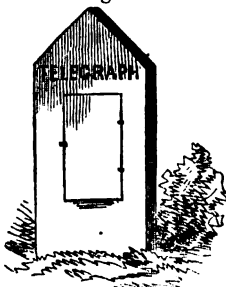

Fig. 9 represents a test-box, made of iron plates, resembling when screwed together a mile post. The small door is fastened with a lock. The line wires, at given distances, for example, every mile, more or less, are brought into these test-boxes, where they can be examined and the place of difficulty ascertained, whether to the right or to the left. Fig. 10 represents the wire, insulated with gutta-percha, separated ready to be tested.

The flat pieces above are brass, and fastened below to the copper wire, covered by the gutta-percha. Fig. 11 represents the two wires fastened together by the double screw at the top of the figure. The projecting nipples seen in fig. 10, fit in the holes seen in the respective pieces, which, together with the double screw in fig. 11, unite the wires tightly. In order to prevent the brass pieces from oxydating, or from causing an earth circuit, a gutta-percha cap is fitted on as seen in fig. 12. All the wires brought into the test-box are thus

Fig. 10.

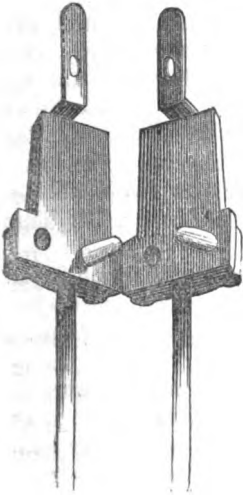

Fig. 11.

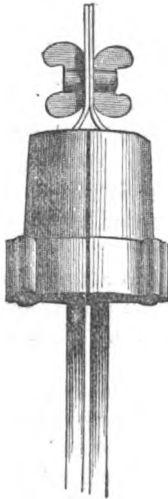
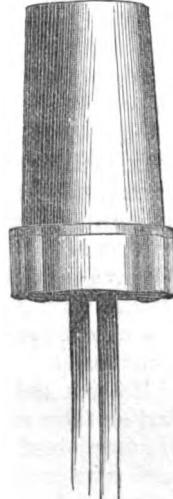

Fig. 12.



arranged. It will be seen from these explanations that it is an easy matter to discover in what direction the fault may be on any wire desired. With instruments nicely adjusted, as to resistance, nearly the precise spot or place at fault can be discovered at one of these test stations, and then by measurement from a marked place, the fault can be discovered and remedied in a few hours.

REPAIRING SUBTERRANEAN TELEGRAPH WIRES.

When the wire is found to be injured as to insulation, it is immediately repaired. This process is executed in the following manner. Figs. 13, 14, and 15, will enable the reader

Fig. 13.

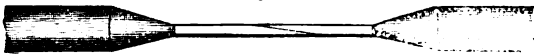

Fig. 14.



Fig. 15.



to understand the mode of splicing a subterranean wire. Fig. 13 is the two ends spliced, having first been cleaned with a file or a piece of sand paper. The ends of the wire it will be



seen, have been filed so as to lap over each other, and yet form but the thickness of the wire. After the ends are thus placed together, a very small copper wire is then wound around the place of splice, as seen by fig. 14. When thus prepared, with a spirit lamp the solder can be spread upon the joint uniting the small with the larger wire. If the solder is not carefully spread on the splice the wires may separate as seen by fig. 15. which ought never to be the case. After the wires are well united, the gutta percha is put on and completes the insulation by uniting it as represented by the dotted lines in fig. 14. This process is as follows :

Have in readiness a few strips about three eighths inch broad of very thin gutta-percha sheet, also a little warm gutta-percha about one eighth inch thick, one or two hot tools, and a spirit lamp.

Remove the gutta-percha covering from along the wire no further than may be necessary for making the joint in the wire. Having joined the wire, warm gently with the spirit lamp the bare wire and joint and the gutta-percha near to it; taper the gutta-percha over the bare wire until the ends meet; warm this and immediately apply one of the strips of thin sheet in a spiral direction over it. Press this covering well on until cool, then, with the spirit lamp, carefully warm the surface and proceed as before to put on a second strip of the thin sheet, observing to wrap it in a direction reverse from the first strip, always making the commencement and termination of these coverings to overwrap the previous ones. It is safer to perform this operation a third time.

Next take a piece of the warm one eighth inch sheet and cover over the coats of thin sheet, again overwrapping the original covering of gutta-percha, which should be heated so as to insure perfect adhesion. Press it well on as it cools, and when cold, or nearly so, finish off the joints with a warm tool, working well together the old and new material at each end.

Lastly, and in general, avoid moisture, grease or dirt, and be careful not to burn the gutta-percha, which would prevent proper adhesion.

I have been quite particular in these explanations in regard to the mending of wires insulated with gutta-percha. Some of the lines, however, in England use wires wrapped with cotton thread, and well coated with a mixture of tar, resin, and grease. This coating forms a perfect insulator, in the opinion of some telegraphers. But some ten years ago I employed this composition to saturate osnaburg coverings to submarine wires, and I did not find it to answer.

# AMERICAN SUBMARINE TELEGRAPHS

## CHAPTER XLII.

Disasters to Mast Crossings over Rivers—Adoption of Submarine Cables—Submarine Cables Perfected—Submerging of the Cable—Bishop's Submarine Cables—Chester's Cable Manufactory—Leaden Covered Telegraph Wires.

### DISASTERS TO MAST CROSSINGS OVER RIVERS.

THE crossing of the rivers by the use of high masts, in America, proved to be unreliable and very expensive. Very often the wires would break and others would have to be substituted. High winds, sleet, snow-storms, and even frost, were severe enemies to the wires. The time required for the repair sometimes amounted to a day or more. Such fatalities bore heavily upon the prosperity of the telegraph. The public, ever restless to complain, could not appreciate the difficulties encountered. The people, however, was not so much incommoded as the treasury of the telegraph company.

Besides the breaking of the wire as above alluded to, the masts were often torn to pieces by the storms. I will give an example of the fatality of some of those masts constructed by me. Early after the completion of those on the Mississippi, a tornado swept over that part of the country, and levelled houses, trees, and the telegraphs. Large brick houses in the city of Cape Girardeau were torn to pieces. Frame buildings were scattered in different directions. Steamers at the river side were wrecked. Several hundred large trees, as much as four feet in diameter at base, were twisted to pieces. The breadth of the terrific tornado was about one mile. It included in its devastating power the telegraph masts; and they, too, were swept from their iron-bound fastenings, and parts of them carried in the wind several miles. A few lives were lost. In its course up the river it even checked the dashing current of the father of waters. The mighty storm came in an instant, and everything within its reach was demolished. It left behind

a calm, and the monuments of ruin were to be seen in every direction. This memorable event was on the 27th of November, 1850.

The mast constructed on the island at the crossing of the Ohio river was swept away by the great flood in January, 1851. Soon after that was repaired, some evil-disposed persons cut down the one at the Tennessee crossing. A few days thereafter the one on the Illinois side of the Ohio river was destroyed by a hurricane; and a few weeks thereafter the great mast on the Kentucky side, 307 feet high, was torn to pieces by a tornado. The five masts just mentioned were erected and destroyed within a space of six months.

#### ADOPTION OF SUBMARINE CABLES.

It was during these misfortunes that my attention was called to the practicability of submarine crossings. Gutta-percha insulated wire had been found to be successful in tide-water streams, but to meet the powerful currents of the Mississippi and Ohio rivers no plan had been devised commensurate with the circumstances. During low water I had submerged No. 10 iron wires covered with three coatings of gutta-percha, but they lasted but a short time. The sand that thickens the water of the Mississippi river would wear off the gutta-percha and leave the iron wire bare. I found many such interruptions. In order to protect the insulation from being thus worn off, I had it covered with three coatings of osnaburg well saturated with tar; and in order to hold the osnaburg on the insulated wire, I had six No. 10 wires lashed to it the whole length, laid laterally. These wires were then tied, by lashing around them a No. 16 iron wire about every twenty inches. When this cable was laid, like all the rest, it worked well for a few months and then failed for ever. Soon after this effort was made, Mr. J. H. Wade was completing his line from the east to St. Louis. The crossing of the river was under the direction of Mr. Andrew Wade. I informed him of my experiments, and he concluded to cover the insulated wire entire with lateral wires laid on to the gutta-percha. They were fastened with ties of small wire at every twelve inches. He constructed the cable in that manner, and it proved to be a success.

#### THE SUBMARINE CABLES PERFECTED.

After this I had made several cables, with some additions to the plan adopted by Mr. Wade. Fig. 1 represents the cable as finally improved by me, in the perfection of which, however, I

was aided by Mr. John B. Sleeth, an experienced mechanical engineer. Letter *a*, the electric conductor, is a No. 10 iron wire, made from the best Swedish bar, and drawn with great care, being capable of sustaining a strain of 1,300 pounds. *b* is the gutta percha insulation, being three coatings carefully manufactured. *c* the three coverings of osnaburg, saturated with a composition made of tar, rosin and tallow. *d* are the No. 10 lateral wires, and *e* the binding wire of No. 12 gauge, placed spirally around the whole cable. Several of these cables were laid in 1853, and some of them are being worked at the present time.

Fig. 1.

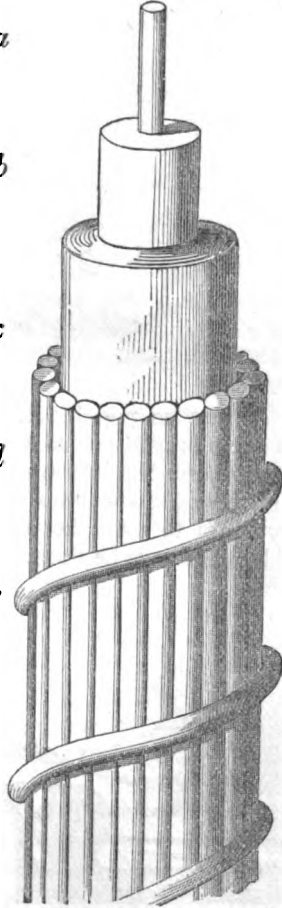

In manufacturing these cables we did not have the convenience of machinery and the variety of mechanical appliances common to populated countries. We were in the West, the great West, in the shades of the forest. The earth was our floor, the blue arched heaven our canopy, and the horizon the only limit of our saloon. Fig. 2 (overleaf) is a representation of the making of the cable. The reel is seen on the left. At the tree a wedge holds fast the finished cable. The men are engaged in putting on the binding wires. The circular board around which the lateral wires are spread is moved forward as the tie process requires. The board distributes the lateral wires around the electric conductor. The gutta-percha insulated wire, covered with the osnaburg, runs through a hole in the centre of the circular board. To avoid confusion, the insulated wire has been left out of the figure.

## SUBMERGING OF THE CABLE.

When the cable has been finished it is ready to be submerged. The frame is erected in a boat and the reel suspended, as seen in fig. 3. The oarsmen then perform their task,

Fig. 2.

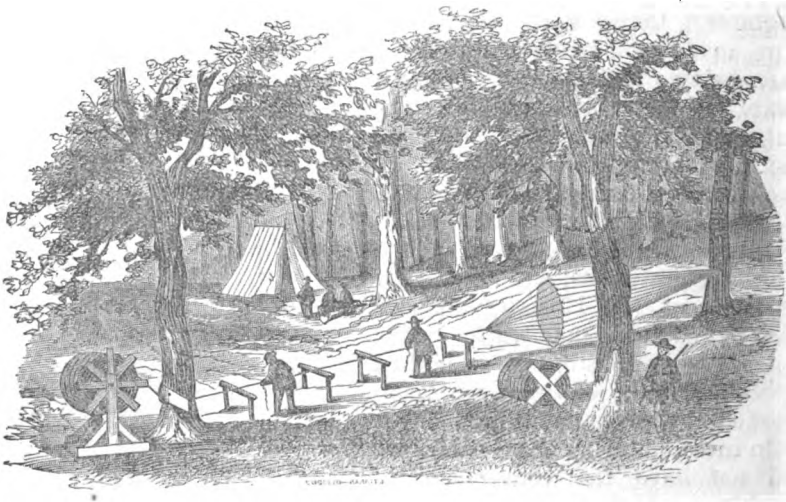

and as fast as possible the boat is rowed across the stream. The cable is paid out as fast as necessary; but the faster the boat traverses the stream the better and more certain will be the success. Sometimes it was possible to get small steam ferry-boats to tow the cable-boat across the river, but this could not always be done.

Fig. 3.

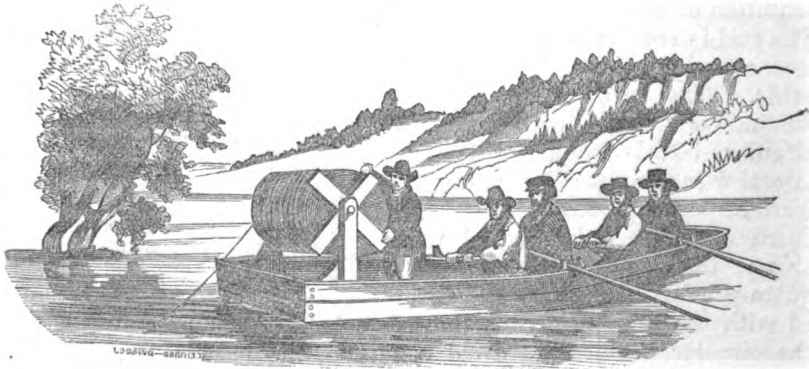

When the Merrimac cable was laid, we toiled through the gloom of night. The sun had gone far behind the western horizon. The moon had come and gone, as though it was hurrying after the god of day that had just withdrawn its last ray; the stars remained, and from the blue depths of their

abode their glimmering beams added to make the scene sublime. In the stillness of night, surrounded by a deep and dismal forest, where the foot of man had seldom trod, we were busily engaged in preparing a pathway for a messenger, mantled in a flame, that was to be the first to greet the rising sun in the east and the last to bid it adieu in the far west—to carry tidings from the ice-bound north to the green palm and blooming magnolia regions of the south. Our couch was God's footstool, and we were sheltered from the dews of heaven by the forest foliage. We were lulled to sleep by the croaking of the frog, the chirping of the cricket, the whooping of the owl and the yell of the panther! Time can never erase from the mind the reminiscences of those scenes—eternity alone can pass them beyond the pale of memory.

Besides the cables constructed under my direction, many others were made and submerged in different parts of America, of which there was one at St. Louis for the O'Rielly line, one at Cincinnati for the House line, another at New Orleans for the Balize line, several across the Hudson at New-York, several on the seaboard line to New-Orleans, and many others across streams and narrow bays.

#### BISHOP'S SUBMARINE CABLES.

These cables have been constructed to meet their special cases. Among those thus employed may be mentioned some that have been laid by Mr. S. C. Bishop of New-York, the gutta-percha manufacturer of America. The first cables laid by this gentleman were those of iron wire, covered with three coatings of gutta-percha, to which were attached lead sinkers. After they had been submerged a few months the insulation was found to be chafed off at the sinkers, and then Mr. Bishop adopted the style and protective coverings represented by figs. 4 and 5.

Fig. 4 is a representation of a cable laid across the Hudson river for the Magnetic Telegraph Company, and successfully worked. Letter *a* is the electric wires of copper, *b* is the gutta-percha coverings around the copper wires singly, *c* is a gutta-percha covering around the insulated copper wires, and *d* is a spiral covering of tarred hempen yarn. Over this cover can be laid an armor of wires of any required size. Fig. 5 is another form successfully operated, which was also devised by Mr. Bishop. The three electric wires *a* are No. 10 Swedish iron, each of 1,300 pounds strength. The interior *b* and the covering *c* are gutta-percha, and *d* is the exterior protective covering of tarred hempen yarn, as in fig. 4.

Fig. 4.

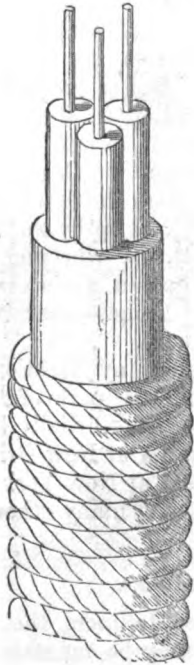
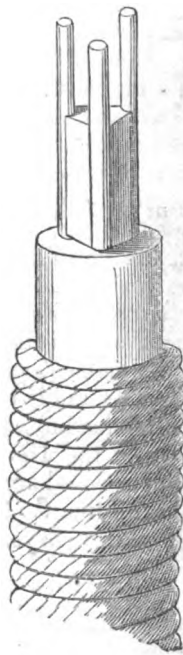

Fig. 5.



## CHESTER'S CABLE MANUFACTORY.

As an auxiliary in the production of telegraph cables, Messrs. Charles T. and J. N. Chester of New-York, have constructed machinery for the covering of gutta-percha insulated wires with hempen yarn, and an iron armor, as seen in figs. 6, 7, 8, 9, 10, and 13. I have examined the machinery employed by these gentlemen, for the covering of cables, and its operation is as perfect as any other to be found on either continent. Fig. 6 is composed of five conducting wires of copper, each insulated with gutta-percha, the whole surrounded with tarred hempen yarn, and then with an armor of twelve No. 6 iron wires. Fig. 7 has one conducting copper wire, with an armor of twelve No. 10 iron wires. Fig. 8 has one conducting wire and an armor of twelve No. 12 iron wires. Fig. 9 has one conducting wire with an armor of nine No. 12 iron wires. Fig. 10 has three conducting wires, with an armor of twelve No. 6 iron wires; and fig. 13 has one conducting wire, with twelve No. 16 iron wires. These different kinds of cables are made to comply with the necessities of different lines or places, and have worked with the most complete success.

Fig. 6.

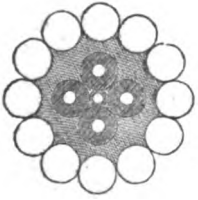

Fig. 7.

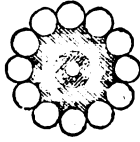

Fig. 8.

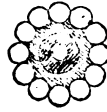

Fig. 9.

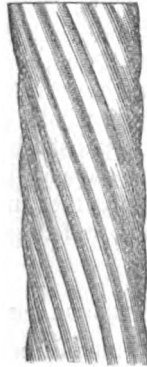
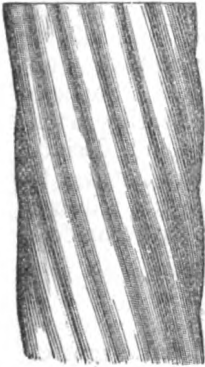

Fig. 10.

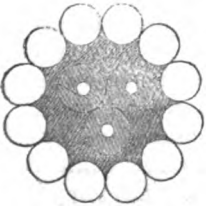

Fig. 11.

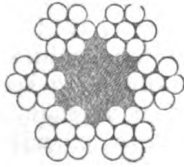

Fig. 12.

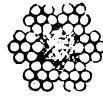
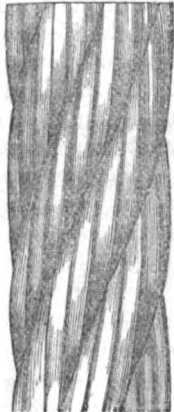
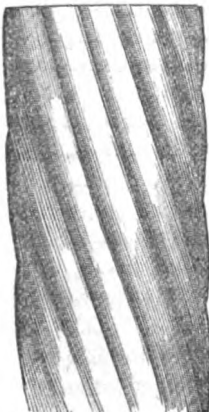

Fig. 13.





In order to give increased strength to the cable, in resisting the great currents of the western streams, such, for example, as the Ohio, Mississippi, and Missouri rivers, the Messrs. Chester have devised the forms seen by figs. 11 and 12. Placing the conducting wire or wires in the interior of these iron cords, it is believed that they will more successfully resist the power of the currents in those streams. Fig. 11 will resist a strain of 14 tons. The reader may be surprised to learn that such powerful cables are necessary to be submerged in the western rivers, but it must be remembered that there are thousands of floating trees descending those rivers, and their roots drag on the bottom, catching into everything in their course. Suppose a tree is held by the cable, the whole current bearing upon that tree will be the strain against the cable; but, besides this, other trees descending are stopped by the one fastened to the cable, and they continue to gather, until they are released from their iron shackles and allowed to go on to the ocean free and unhindered.

#### LEADEN-COVERED TELEGRAPH WIRES.

In order to cross swamps and marshy countries, and to protect the insulation for subterranean and subaqueous purposes generally, Mr. Bishop has constructed extensive machinery for the covering of the insulated wire with lead of any required thickness. These leaden covered wires have been extensively employed, and have thus far proved to be durable and perfect as to insulation. Some of these wires have been buried in earth and water several years, and thus far show no signs of decay. One of these leaden covered wires extends from the central telegraph station in the city of Washington to the Capitol of the United States, connecting with the telegraph apparatus in the rear of the speaker's chair of the House of Representatives. From the Capitol the proceedings of Congress are transmitted to different parts of America. By this arrangement the President's message, on being read in Congress, can be transmitted on the radiating wires east, west, north, and south, and communicated simultaneously to millions of people.

# EUROPEAN SUBMARINE TELEGRAPHS.

## CHAPTER XLIII.

The English and French Cables—Mode of Shipping and Submerging Cables—Holyhead and Howth Telegraph—The Irish Channel Cable of 1852—The English and Belgian Submarine Telegraph—Donaghadee and Port Patrick Submarine Line—English and Holland Submarine Cable—Prince Edward's Island Cable—Danish Baltic Sea Telegraph—The Gulf of St. Lawrence Telegraph—The Balize, Hudson and Zuyder Zee Cables—The Black Sea Telegraphs—The Mediterranean Submarine Telegraph Lines.

### THE ENGLISH AND FRENCH CABLES.

HAVING fully explained in another chapter the different submarine telegraph conductors as employed in America, I will in this refer to those of Europe, where that department of the telegraph enterprise has been carried out to a far more extended degree.

The first prominent undertaking was that for the connection of England with France by a subaqueous conductor across the channel between Dover and Calais. A concession was obtained for this purpose from the French government, but upon the condition that the connection by telegraph was to be effected before September, 1850. On the 27th of August, 1850, a cable was laid across the channel, and communication was made, telegraphically, through the wire. Unfortunately this grand enterprise was interrupted by the action of the waves, which produced a movement of the cable upon the rocks near the shore at Cape Grinez, by which the gutta-percha insulation was chafed entirely from the conducting wire. This cable was composed of an electric copper wire No. 14, and covered with three substantial coatings of gutta-percha. It was weighted to the bottom of the sea by lead sinkers. Its length was thirty miles, and the width of the channel was twenty-one miles. I have a piece of this cable taken from the sea after it had been submerged some five years. The gutta-

percha was then and is now in good condition and as solid as when first made; and notwithstanding it has been kept dry, it maintains its solidity and gives no evidence of decay. Barnacles and sea-weed had formed upon it; and from every indication there are reasons to believe that the gutta-percha as a substance would have remained a perfect insulation for all time to come.

The working of the cable was sufficient to maintain the integrity of the concession, and therefore it was respected in good faith.

Fig. 1.—Dover Cable.

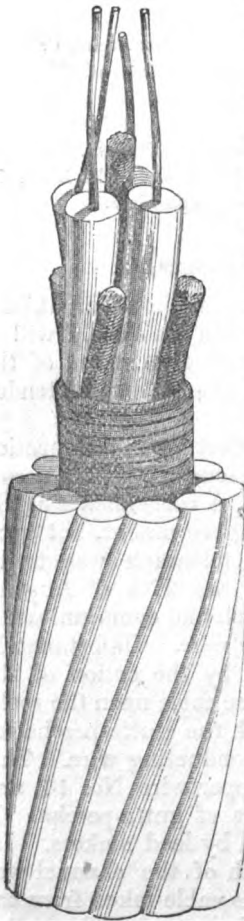

In the year 1851 another cable was prepared by Messrs. Newall & Co., of Gateshead. The energy and superior skill of these gentlemen were eminently successful in the production of a cable equal in every respect to the emergencies of the enterprise. It was a noble achievement in mechanics. The triumphant success in the invention of that cable was the grandest part of the enterprise. Fig. 1 represents the construction of the cable above referred to: *a* are four conducting wires, No. 16, copper; *b* is a cord of tarred hemp, slightly twisted; *c* represents the gutta-percha around the copper wires; *d* are hempen cords like *b*; *e* is a serving of tarred hemp spirally twisted around the core composed of *a*, *b*, *c* and *d*; and *f*, the iron wires, spirally laid, as seen in the figure.— These ten iron wires were galvanized with zinc and tightly laid around the interior combination with great care, by a perfect organization of machinery.

This cable was successfully laid on the 17th of October, 1851, from Dover to Calais. It was 25 miles long, and manufactured in the short space of three weeks. The cost of the cable was £360 per mile, and the total cost of the undertaking was estimated at £15,000. Its weight per mile was seven tons. On its completion, the four conducting wires were found to be per-

fectly insulated, and operated with the most complete success. The success of this enterprise opened a new era in telegraphing

I have a section of this cable after it had been submerged four years, and although a part of the galvanized surface of the exterior armor seems to have been eaten away or chafed off in the sea, it is, as a whole, perfect as it was the day it was laid. Fig. 2 is another representation of a section of this cable. The transverse section is the natural size.

Fig. 2.—Dover Cable.

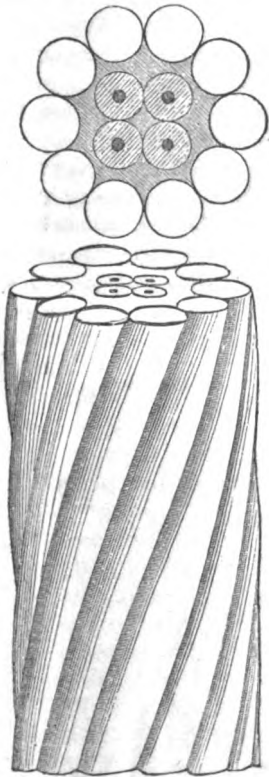
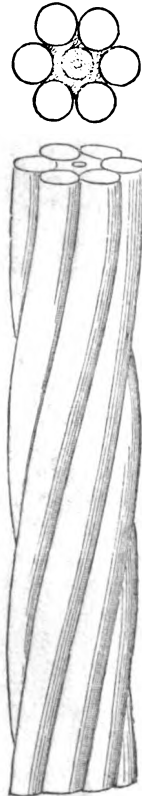

Fig. 3.—Holyhead and Howth. Deep sea part.



Fig. 4.—Holyhead and Howth. Shore ends.



MODE OF SHIPPING AND SUBMERGING TELEGRAPH CABLES.

Before entering into a detailed explanation of the respective cables adopted in Europe, I will briefly refer to the manner of submerging them from the vessel.

Fig. 5.

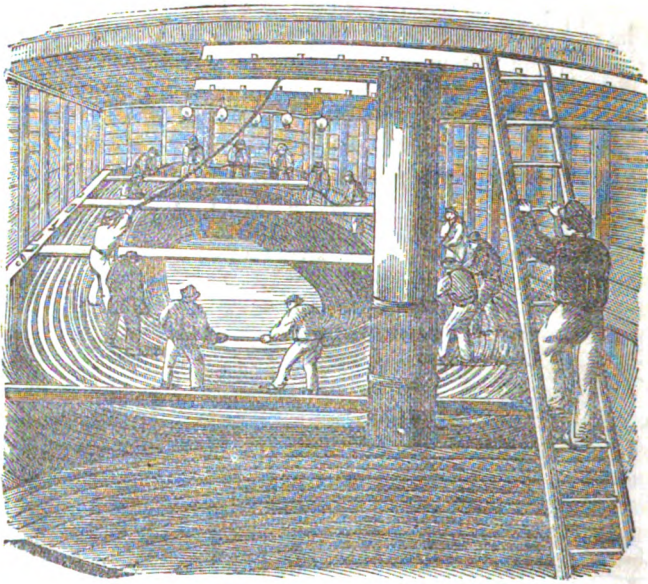

Fig. 6.

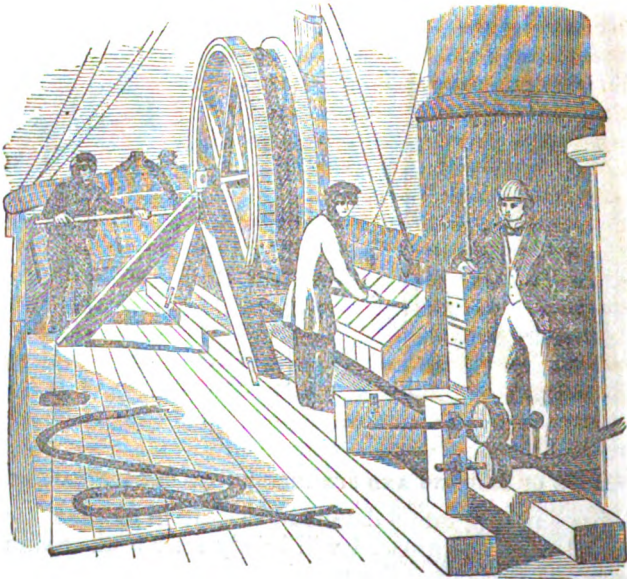

Fig 5 represents the coiling of the cable in the hold of the ship. This and the next figure have been copied from the London Illustrated News, and they are excellent representations of the subjects. I was present and witnessed the coiling of a section of the great Mediterranean cable in the vessel at Greenwich, near London, in 1854, and the scene represented by fig. 5 was taken on that occasion. In like manner other cables have been coiled in the vessel, proper care always being taken to prevent twists or kinks of any kind. When the cable is thus properly placed in the ship, it will pay out into the sea without hazard, except when interfered with by storm or unforeseen causes.

Fig. 6 represents the paying out of the cable from the deck of the vessel into the sea. The cable ascends from the hold of the ship and passing between guide rollers, as seen to the right in the figure, passes on to the break drum, and after encircling that some two, three or more times, as circumstances require, it is conducted over the stern of the vessel and dropped into the water, where it soon finds a resting-place upon the bottom, far below the influence of storm and tempest, and where it is supposed by philosophers there are no movements of the mighty waters nor a single element to disturb its quiet repose. The mechanism adopted for the paying out of cables is not always the same, though in general principle there is but little difference. Circumstances may require an occasional modification of certain parts, yet every plan contemplates the attainment of two essential considerations; first, the paying out of the cable to avoid kinks or any kind of entanglement; and second, to pay it out at a speed commensurate with that of the vessel.

#### HOLYHEAD AND HOWTH SUBMARINE TELEGRAPH.

The most remarkable feat ever performed in the laying of a cable was in connection with that from Holyhead on the Welsh coast, to Howth on the coast of Ireland, on June 1st, 1852, by Messrs. Newall & Co. Several companies had been projected to carry out the telegraphic connection between Ireland and England on the route above mentioned. Capital was being raised and great arrangements were being perfected to accomplish the gigantic undertaking. The distance across the channel was sixty miles, and it was estimated that at least ten miles plus would be required in submerging it. The length of wire was insulated with gutta-percha by Messrs. Statham & Co., at their extensive establishment in London. It was then shipped to Messrs. Newall & Co., at Gateshead on the

Tyne, where it was enveloped with its iron armor in the short space of four weeks. This cable was made for the deep and for the shoal water, as represented by figs. 3 and 4.

The former was for the deep water and made light, as will be seen from the figure, which represents the full size of the cable. Its weight was a little less than one ton per mile, making a total of about eighty tons. The shore ends will be seen by reference to fig. 4, being surrounded with larger wires, forming an armor capable of resisting the waves on the rocky coast.

The cable was completed and conveyed across England to Maryport on the railway. At Maryport it was placed on board the vessel and transported to Holyhead. One end was carried on shore and made fast, the vessel then proceeded to submerge it across the channel. The depth was seventy fathoms. Sixty-four miles of the cable were successfully laid and operated. After the third day it failed. It was supposed at the time that the anchor of a vessel had produced a separation of the wires, and on being taken up they were found broken and very badly stretched. This was near the Irish shore. About a year after the failure of this cable, a ship having made a cruise to South America, arrived at New-York with a piece of the cable which had been cut or broken off by the sailors. It was not until after the arrival of the vessel in America, that the sailors or any of the crew knew what the great and mysterious prize was that they had kept with such care.

#### THE IRISH CHANNEL CABLE OF 1852.

In the month of October, 1852, Messrs. Newall & Co. embarked with another cable across the Irish channel, connecting Scotland with Ireland, at the narrow part of the channel, between Donaghadee and Port Patrick. This cable is represented by fig. 7, the construction of which will be readily understood by the reader. The vessel while laying this cable and sixteen miles from shore encountered a severe gale, and it was impossible to steer it in the proper course. To hold out against the

Fig. 7.—Irish Channel Cable.

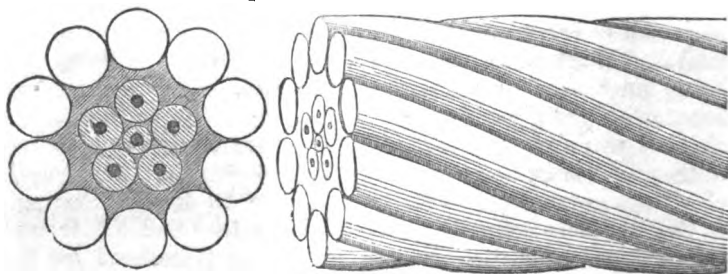

storm much of the cable would have been lost in the sea, and the remainder on board would not have been enough to have reached the opposite shore, although the vessel was within seven miles of the Irish coast, and had nine miles of cable on board. It was deemed necessary to cut the cable, which was promptly done, and the sixteen miles lay at the bottom as a treasure of the sea. In 1854, this cable was raised by Messrs. Newall & Co., and pieces of it were shown me by those gentlemen in London. It was found to be perfect and the wire but little decayed. A crust of barnacles was formed over it, and there can be no doubt but that it would have continued good for all time.

It was a vast undertaking to elevate that cable. The water was 150 fathoms deep. Some of the cable was buried in the sand, other parts covered with sea-weed, and other parts with barnacles or various kinds of shells. With the aid of a powerful engine the cable was recovered. On testing it after its recovery it was found to be perfect as to insulation.

#### THE DOVER AND OSTEND CABLE.

The cable between Dover and Ostend was laid on the 6th of May, 1853, twenty minutes before one p. m. It was constructed by Messrs. Newall & Co., and was seventy miles long. This was the greatest and most memorable accomplishment of that age. It was a triumph in art that will for ever do honor to those gentlemen. Fig. 8 represents this cable, containing six wires. The armor of the cable is composed of twelve iron wires, the whole capable of sustaining a strain of about fifty tons. The inner wire did not prove a success. It weighed seven tons per mile, making a total of nearly five hundred tons. It was manufactured in one hundred days, and cost £33,000. It required seventy hours to coil it in the ship, and it was submerged in the sea from Dover to Ostend in eighteen hours. Up

Fig. 8.—Dover and Ostend Cable.

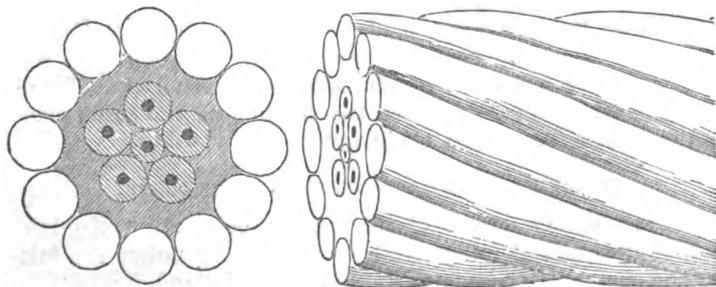



to that time there had been no achievement in telegraphing equalling that stupendous undertaking, and there never was an enterprise crowned with more signal success. The industry and enterprise of those gentlemen seem to have had no bounds; for wherever there has been an opening to extend the lightning flash they have always been foremost, and no obstacles, however great, have ever checked them in their career.

THE DONAGHADEE AND PORT PATRICK SUBMARINE LINE.

After the success in the submerging of the Dover and Ostend cable, Messrs. Newall & Co. renewed their efforts to lay a cable between Donaghadee (Ireland) and Port Patrick (Scotland), across the Irish channel. This cable was of the same size and

Fig. 9.—Donaghadee and Port Patrick Cable.

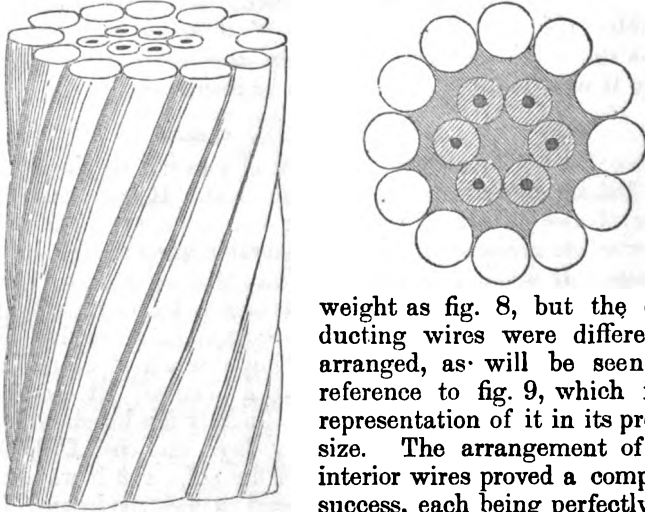

weight as fig. 8, but the conducting wires were differently arranged, as will be seen by reference to fig. 9, which is a representation of it in its proper size. The arrangement of the interior wires proved a complete success, each being perfectly insulated from the other so that each was capable of being serviceable for telegraphic purposes. This cable was manufactured in the short space of twenty-four days by Messrs. Newall & Co. The cost of it was about £13,000. It was laid for the Magnetic Telegraph Company. Another cable of the same make was laid across the channel at the same place for the British Telegraph Company.

ENGLAND AND HOLLAND SUBMARINE TELEGRAPH.

I have already described the cables connecting England with France and Belgium, and I now come to notice the telegraphic connection between England and Holland.

Fig. 10.—Orfordness and the Hague Cable.

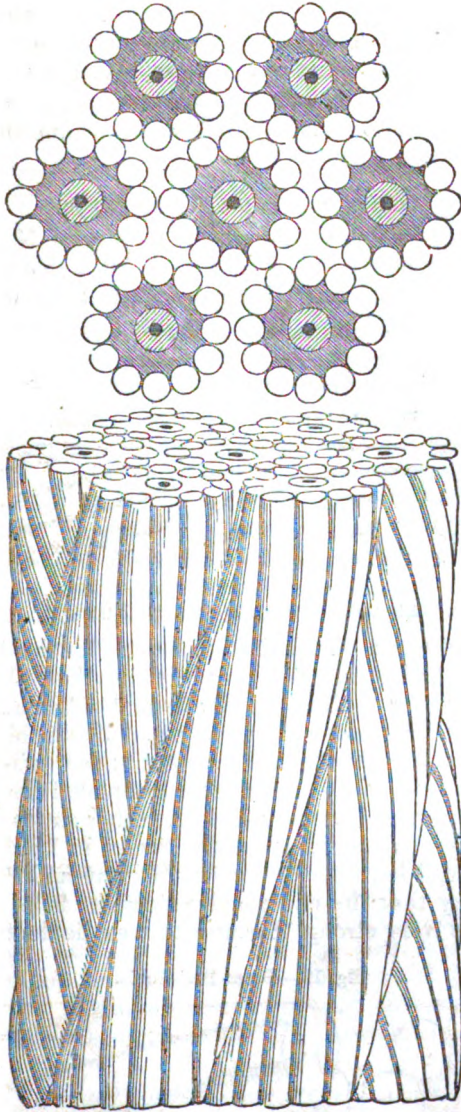

The cable is laid between Orfordness on the Suffolk coast, and the Hague in Holland. There are now three cables laid between these places, each of which has one conducting wire, and covered with an armor of twelve iron wires. They are

laid some three miles apart across the channel, and near the shore they are connected together in one great cable as represented by fig. 10. The shre ends are made as seen in the figure, being composed of seven lesser cables, such as are laid in the sea, twisted together, forming one of great strength and size. It is intended to lay the other four across the sea whenever the business requires them.

#### PRINCE EDWARD'S ISLAND CABLE.

A submarine cable manufactured by Messrs. Newall & Co., as represented by fig. 11, was laid in 1852 between Prince Edward's Island and New Brunswick, a distance of ten miles. It worked successfully. This was intended as a part of the telegraph, designed to run from Prince Edward's Island to the island of St. Paul, or to the west coast of Newfoundland.

Fig. 11.—Prince Edward's Island Cable.



#### THE DANISH BALTIC SEA TELEGRAPH.

Fig. 12 represents the cable constructed for the Danish government and laid across the great belt of the Baltic sea. It runs from Nyborg to Korsøe on the Island of Zealand, connecting there with the line to Copenhagen. This cable has three electric wires well insulated and surrounded with an armor of nine large iron wires. The cable completed the telegraphic connection between Denmark and the other states of Europe, and by another cable laid across the Sound in 1854, a connection was formed between Denmark, Norway and Sweden. It was necessary that the cable laid across the belts of the Baltic should be very strong, because it was liable to be drawn

Fig. 12.—Great Belt Cable.

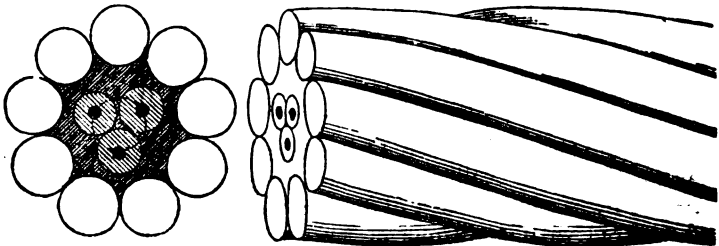

up frequently by the hundreds of vessels that annually pass through those narrow arms of the sea. The one adopted has proved to be a success in every particular.

THE GULF OF ST. LAWRENCE TELEGRAPH.

The New-York, Newfoundland, and London Telegraph Company, attempted to lay a cable similar in construction to fig. 12 across the Gulf of St. Lawrence, from the west coast of Newfoundland to the east coast of Nova Scotia in August, 1855, but owing to the violence of a storm encountered by the steamer during the submerging of it, when thirty-two miles from the Newfoundland coast, the cable had to be severed from the vessel. Forty miles of it had been paid out, and it was evident that the remainder on board could not have reached the opposite coast. Besides this lamentable misfortune, several kinks had been made, and two of the three conducting wires had failed. But one was left. The route of the vessel was then changed toward St. Paul's Island, but the sea was so high and the gale so violent, that the further laying of the cable was considered impossible without the most imminent hazard to the vessel and the lives on board. To save the vessel and those on board the cable was cut. The loss was serious and one deeply to be regretted.

In 1856, another cable was laid across the Gulf of St. Lawrence. This latter was not as heavy as the former one was, and it had a conducting cord made of four small copper wires twisted together. This electric cord was evidently an improvement on the former conductors. It gave to it additional strength and conductivity. It has worked successfully with some few slight interruptions.

THE BALIZE, HUDSON, AND ZUYDER-ZEE CABLES.

Fig. 13 represents a cable constructed by Messrs. Newall & Co. for the Balize telegraph at New-Orleans. It has been successfully submerged opposite the city and worked with entire satisfaction. A cable like fig. 13 has been made by the same gentlemen and laid across the Hudson river at New-York city. Several other cables have been made by Messrs Newall & Co., and submerged in different parts of America and worked with

Fig. 13.

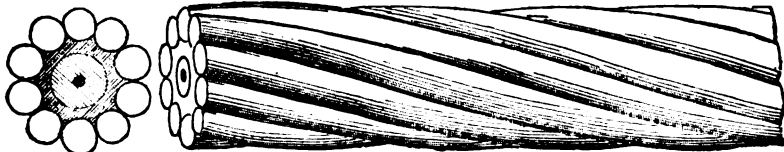

perfect success. A cable similar to fig. 7 was laid across the Zuyder-Zee, a distance of five miles.

#### THE BLACK SEA SUBMARINE TELEGRAPHS.

The most remarkable submarine telegraph was that laid by Messrs. Newall & Co. between Varna and Balaclava, one hundred and fifty miles across the Black sea, during the late war, by which, with another two hundred miles long through the sea from Varna to Constantinople, the whole continent was placed in telegraphic communication with the Crimea and the capital of Turkey. These lines, however, were laid for government service. The line between Varna and Constantinople consisted of one copper wire thickly insulated with gutta-percha and covered with an armor of iron wires. Its weight was about two hundred tons. The line between Varna and Balaclava was a No. 16 copper wire, covered with three thin coatings of gutta-percha, being about the size of one of the insulated wires seen in fig. 1. Near the shore protecting wires were placed around it. This line was laid by Messrs. Newall & Co. for £22,000. It worked with the most complete success. This was certainly the boldest and yet most triumphant feat in submarine telegraphy. It has not its parallel in all history. It is wonderful to reflect upon this extraordinary enterprise, successfully submerged and practically worked across the most restless and turbulent sea upon the face of the earth. While above the storm raged, strewing the ocean's surface with wrecks, the tiny strand, unaffected by the tempest's blast, quietly lay in the depths below, traversed by the electric fluid, giving note of the progress of that war of empires upon the seagirt battle-field of the Crimea. Imagination pales before such achievements of daring and scientific effort.

#### THE MEDITERRANEAN SUBMARINE TELEGRAPH LINES.

Another very remarkable telegraphic feat is that of connecting Europe with Africa, for the consummation of which concessions were awarded by the French and Sardinian governments. The right was given to transmit intelligence in all languages. The concessions were to extend for fifty years from 1853. The line runs from Spezzia to Corsica. The submarine cable connecting these two places has six conducting wires, as seen by fig. 14. The length of the cable is one hundred and ten miles, of which twenty miles was estimated for slack in the sea. I was present at the embarkation of the cable in 1854, and saw some of it manufactured by Messrs. Kuper & Co., at Greenwich, near London. It is similar in construction to the cable

Fig. 14.—Mediterranean Cable.

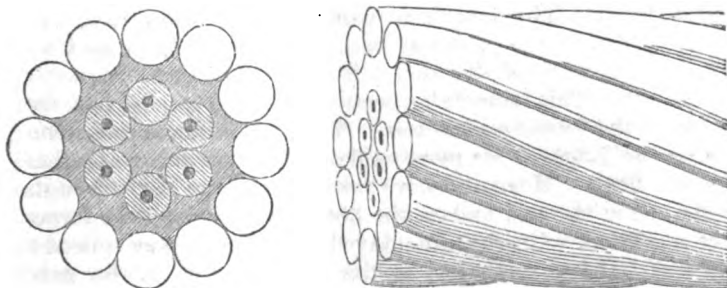

laid across the Irish channel from Donaghadee to Port Patrick. In the laying of this cable from Spezzia to Corsica the vessel encountered a very severe storm and for a while there were great apprehensions that the cable would be lost. Its great strength preserved it. From the termination of the cable on the Island of Corsica there is a land line one hundred and twenty-eight miles in length, extending to the Straits of Bonifacio, where a short submarine line of seven miles runs to the Island of Sardinia, across which there is a line two hundred and three miles long, terminating at Cape Spartivento. The consummation of telegraphic connection between the Island of Sardinia with Africa seems to have been surrounded with very great difficulties. Two attempts were made, under the direction of Mr. John W. Brett, to make the connection, but both failed. The first was in September, 1855, with a cable represented by fig. 14. The second was in August 1856, with a cable containing a four strand copper cord for the conducting wire, surrounded with an armor of iron wires similar in construction to the cable laid across the Gulf of St. Lawrence.

Fig. 15.

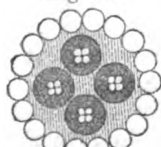
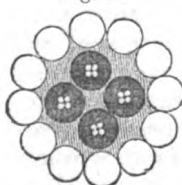

Fig. 16.



In September, 1857, Messrs. Newall & Co. contracted to lay the cable at their own risk. It was manufactured by them and was composed of an organization as seen by figs. 15 and 16; the former being the deep-sea cable and the latter the shore ends.

The iron armor of the deep-sea cable was composed of eighteen iron wires, and that of the shore end twelve iron wires. The distance between Bona on the African coast to Cape Spartivento, Sardinia, was one hundred and twenty-five miles. Length of cable on board, one hundred and sixty-two miles. Shore cable six miles.

In the laying of the above cable there were many difficulties encountered. The length of cable was too short, and after splicing to it all the pieces at command, when the vessel was within ten miles of the shore, in eighty fathoms of water, it was lost. This lamentable occurrence, however, did not seem to daunt the heroic contractors. They immediately dispatched a vessel to England for more cable, which returned to Cagliari October 28th. Measures were taken to recover the end of the cable lost in the sea, and on the 30th it was found to be in perfect condition. On the same day the new cable was spliced to the end that had been lost in the sea. At 1 p. m. the cable was safely landed on shore. At 4 p. m. on the 30th of October, the first lightning flash from Europe to Africa was accomplished, adding new lustre to the wide-spread fame of Messrs. Newall & Co.

The next grand stride in the extension of submarine telegraphy was the connection of Malta and Corfu with the Island of Sardinia. This was also executed by Messrs. Newall & Co., as contractors under the Mediterranean company extended.

Fig. 17.



Fig. 18.

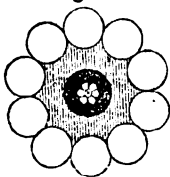

The cable which was laid on this route is represented by figs. 17 and 18, the former for the deep sea and the latter for the shore ends. The inside or electric cord is composed of seven small copper wires twisted together, forming a cord. The outside was an armor of eighteen small iron wires. The shore ends, as seen by fig. 18, were larger, and covered with ten iron wires. The weight of the deep-sea cable was 1,960 pounds.

The *Elba* arrived at Cagliari, Sardinia, on the 10th of November, 1857, having on board eight hundred miles of the cable. The *Desperate*, of Malta, had taken the soundings on the route, and the *Blazer* was the guide ship. On the 13th of November the vessels sailed to St. Eliza, some four miles south of Cagliari, where the cable was landed, and on the 14th the ships embarked on their great mission, leaving all things behind in perfect order. On the 15th a very severe storm arose, and at noon it was so violent that the waves ran a foot deep over the deck of the vessel. The ship labored in the turbulent sea, and at the time the paying out of the cable was very irregular. At eleven o'clock on the 16th, as the ship was contending against the waves, a heavy sea struck it with great violence and threw it upon its side, displacing the cable from its coil.

On the 17th the Island of Goro was in sight and soon there-

after the little fleet moored in St. George's Bay, north of La Valette, Island of Malta. The whole laying occupied seventy-two hours. Three hundred and seventy miles of cable were paid out. The electric flash was transmitted through the cable with perfect success.

On account of the unfavorable weather, the laying of the cable from Malta to Corfu was suspended, and it was determined to submerge it from Corfu to Malta to avoid head winds. To this end the vessels sailed to Corfu. The town of Corfu lies on the east side of the island. The St. Gordo Bay lies on the west side, where the cable was carried ashore. The end of the cable was connected with the land line which runs over the island to the town of Corfu.

At 11 a. m., on the 1st of December, 1857, the fleet sailed, the *Desperate* piloting the way and the *Blazer* serving as tender. The weather was very fine and prospect of success encouraging. December 3d, the greatest depth, eight thousand feet, had been passed, and on the 4th at noon the whole cable was submerged without accident. The vessel anchored in St. George's Bay, and the cable soon thereafter conducted on to the Malta shore. Amount paid out, four hundred miles, and the time occupied seventy-two hours. On the 5th the news of the great triumph was announced in London. The whole cost of the line was £125,000. In this enterprise the intrepid contractors won for themselves and their nation a renown more brilliant than deeds achieved at the cannon's mouth.



# ATLANTIC OCEAN TELEGRAPHY.

## CHAPTER XLIV.

The Atlantic Telegraph Company organized—Principles of Philosophy presumed by the Company—The Expedition for laying the Cable in 1857—The first Expedition of 1858—The Second Expedition of 1858—Working of the Telegraph Cable—Cause of the Failure of the Cable to operate.

### ORGANIZATION OF THE ATLANTIC TELEGRAPH COMPANY.

To whom the world is indebted for the suggestion of an Atlantic Telegraph is not a question of any material consequence. Those who devised the ways, the means, and the elements of art, in the consummation of the enterprise, are the ones to whom honor is due.

The character of this work renders it impossible for me to mention the names of the brave and dauntless men who planned and executed the submersion of the different Atlantic cables of 1857 and 1858, having in view the connection of the eastern with the western hemispheres—Ireland in the Old World with Newfoundland in the New.

While I have no faith that a telegraphic cable, laid in the ocean two thousand miles, can be made available for practical telegraphic purposes, with the present known sciences, it is but fair to say that there are those of high scientific attainments, who have the fullest confidence in the ultimate realization of the most complete success. The reasons impelling me to disbelieve in the practicability of the enterprise are strictly scientific, and those reasons will be considered elsewhere in this work, in explanation of voltaic currents and their transmission over conductors through air, and on subterranean and submarine lines.

The Atlantic Telegraph Company was registered under the Limited Liability Act of 1856, on the 31st of October of that year.

On the 5th of December, in the same year, the whole of the shares had been fully subscribed for, and in a few days afterward the entire deposit of £200 per share had been paid up.

On the 9th of December, 1856, the Board of Directors was appointed by the shareholders. The first business before the company thus organized, was the selection of a cable, and after much careful investigation, the one adopted was as represented by fig. 1.

This cable was composed of 7 small copper wires twisted together, forming a cord. Around this copper cord, was placed the gutta percha insulation, carefully manufactured. Next was placed the tarred hempen covering, and around the core thus made was placed the iron armor, consisting of 18 cords of small wire as seen in fig. 1. There can be no doubt but what the organization of the cable was as perfect as could be devised. It might have been improved by making it a little more buoyant, but even that is not a settled fact. It was a great mechanical work, and conceived by a master thought. On the 31st of December the contracts for 2,500 miles of the cable were concluded. the whole to be ready by the first week in July 1857. The manufacturers of the immense cable, were Messrs. Newall & Co., and Messrs. Glass, Elliott & Co., London.

Fig. 1.

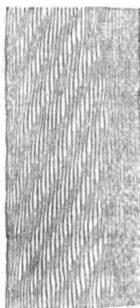
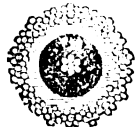

#### PRINCIPLES OF PHILOSOPHY PRESUMED BY THE COMPANY.

The promoters of the Atlantic Telegraph, as a preliminary, satisfied themselves that the following philosophical points were true, viz.:

1st. That telegraphic signals could be transmitted without difficulty through the required distance;

2d. That a large conducting wire was not required for the purpose; and

3d. That the communication through the conductor could be effected at a thoroughly satisfactory speed.

Subsequent investigation induced the company to officially announce the following as established facts in philosophy:

1st. That gutta percha covered submarine wires do not transmit as simple insulated conductors, but that they have to be charged as Leyden jars before they can transmit at all.

2d That consequently such wires transmit with a velocity

that is in no way accordant to the movement of the electrical current in an unembarrassed way along the simple conductors ;

3d. That magneto-electric currents travel more quickly along such wires than simple voltaic currents ;

4th. That magneto-electric currents travel more quickly when in high energy than when in low, although voltaic currents of large intensity do not travel more quickly than voltaic currents of small intensity ;

5th. That the velocity of the transmission of signals along insulated submerged wires can be enormously increased, from the rate indeed of one in two seconds to the rate of eight in a single second, by making each alternate signal with a current of different quality, positive following negative, and negative following positive ;

6th. That the diminution of the velocity of the transmission of a magneto-electric current, in induction-embarrassed coated wires, is not in the inverse ratio of the squares of the distance traversed, but much more nearly in the ratio of simple arithmetical progression ;

7th. That several distinct waves of electricity may be travelling along different parts of a long wire simultaneously, and within certain limits, without interference ;

8th. That large coated wires used beneath the water or earth are worse conductors, so far as velocity of transmission is concerned, than small ones, and therefore are not so well suited as small ones for the purpose of submarine transmission of telegraphic signals ; and

9th. That by the use of comparatively small coated wires, and of electro-magnetic induction coils for the exciting agents, telegraphic signals can be transmitted through two thousand miles with a speed amply sufficient for all commercial and economical purposes.

On the night of the 9th of October, 1856, some experiments were instituted which were regarded of great importance. "Ten gutta-percha insulated wires, each measuring more than 200 miles, were connected, so that one continuous circuit of above 2,000 miles was formed. There were coils of five wires, introduced for experimental purposes at the joints of the wires, further increasing the circuit virtually to the amount of 2,300 miles. The magneto-electric induction coils of Mr. Whitehouse were used to excite the wires, and the current was made to operate by means of the receiving apparatus, upon one of Professor Morse's ordinary recording instruments. Signals were distinctly and satisfactorily telegraphed through the two thou-

sand miles of wire, at the rate of 210, 241, and upon one occasion, 270 per minute."

The friends of the enterprise supposed that like results would be accomplished on the ocean cable, and that, as a commercial fact, twenty words could be transmitted through the cable per minute. Under the belief that these things would be realized by the telegraph, capital was raised, and the company with rapid strides proceeded to the completion of the enterprise.

#### THE FIRST EXPEDITION FOR LAYING THE CABLE.

The British government detailed the ship *Cyclops*, and the United States government detailed the *Arctic*, to take the soundings of the ocean on the proposed route. And to lay the cable, the British government detailed the ships *Agamemnon* and *Leopard*, and the United States, the *Niagara* and *Susquehanna*.

The cable was completed in due time, and placed on board of the respective vessels; and on the 5th of August, 1857, at Valentia Bay, Ireland, the end of the cable was taken on shore from the *Niagara*. After some few incidental delays, the fleet sailed from Valentia on the 7th of August. All the cable had been put on board of the *Niagara* and the *Agamemnon*. The other vessels served as tenders. The cable was being laid with success, until the morning of the 11th of August, when it broke, and was lost in the sea. There had been submerged 380 miles. To enable the reader to understand the particulars of this expedition, I insert the following from the report of Sir Charles T. Bright, the distinguished engineer of the company:

"Early in the month of April, 1857, *H. M. S. Agamemnon* was placed at my disposal as your engineer; and the fittings necessary to adapt her to the reception of the cable having been carried out with the utmost rapidity, she was moored at her station at Greenwich to take in the eastern half of the cable.

On the 14th of May, the U. S. frigate *Niagara* arrived in the Thames; but, on calculating the space available for our requirements, it was found that considerable alterations would be necessary to suit her interior to our purpose. These were put in hand at Portsmouth, and she finally proceeded to Birkhead, to receive her portion of the cable.

In the *Agamemnon*, by clearing her hold of the tanks and magazines, the available space allowed of the cable being made into one great coil, forty-eight feet in diameter and twelve feet

high. In the Niagara, it had to be disposed in five coils, three in the hold, orlop-deck and berth-deck forward, and two on the berth and main decks aft.

The machinery for regulating the egress of the cable from the paying-out vessels was constructed with regard to the great depths of water to be passed over, the constant strain, and the number of days during which the operation must be unceasingly in progress.

The cable was passed over and under a series of sheaves, having the bearings of their axles fixed to a framework, composed of cast-iron girders bolted down to the ships' beams.

The sheaves were geared to each other, and to a pinion fixed to a central shaft, revolving at a rate three times faster than that of the sheaves; two friction drums upon this shaft regulated the speed of paying-out, and the grooves of the sheaves (which were fixed to their axles outside the framework and bearings) were fitted to the semi-circumference of the cable, so as to grasp it firmly, without any pressure by which it could be injured.

I need not here enter into the arrangements for splicing, buoying, guard-ropes, staff, lights, and other minor details of the expedition, nor into the causes which led to your resolution, that the laying of the cable should commence from Ireland, instead of from the centre, as was at first contemplated. On the 29th of July, the two ships, with the whole of the cable on board, met at Queenstown. On the 3d of August, after uniting the two lengths, to test the conductivity of the entire line, and taking in coals and sundry stores, we started for Valentia, in company with H. M. S. Leopard and the U. S. frigate Susquehanna, two powerful paddle-wheel steamers, appointed to render assistance in case of need.

At Valentia, we were met by H. M. S. Cyclops, and on the 5th, the end of the cable was landed at Ballycarbery strand from the Niagara, which lay in the bay about two miles distant.

An accident to the heavy shore end cable shortly after weighing anchor on the 6th, deferred our final departure until the 7th of August.

For three days everything proceeded as satisfactorily as could be wished; the paying-out machinery worked perfectly in shallow, as well as in the deepest water, and in rapid transition from one to the other; while the excellent adaptation of the cable in weight and proportions to the purpose was most forcibly demonstrated by the day's work previous to the mishap,

during which one hundred and eighteen miles of the cable were laid, for one hundred and eleven miles run by the ship.

The details of the voyage from the 7th until the morning of the 11th, are fully set forth in the following extract from a report made by me to the board shortly afterward :

• By noon, on the 8th, we had paid out forty miles of cable, including the heavy shore end, our exact position at this time being in lat.  $51^{\circ} 59' 36''$  N., long.  $11^{\circ} 19' 15''$  W., and the depth of water, according to the soundings taken by the Cyclops, whose course we nearly followed, ninety fathoms.

Up to four p. m. on that day, the egress of the cable had been sufficiently retarded by the power necessary to keep the machinery in motion, at a rate a little faster than the speed of the ship ; but as the water deepened, it was necessary to place some further restraint upon it by applying pressure to the friction drums, in connection with the paying-out sheaves ; and this was gradually and cautiously increased from time to time, as the speed of the cable compared with that of the vessel, and the depth of the soundings, showed to be requisite.

By midnight, eighty-five miles had been safely laid, the depth of water being then a little more than 200 fathoms.

At eight o'clock in the morning of the 9th, we had finished the deck coil in the after part of the ship, having paid out 120 miles ; the change to the coil between decks forward was safely made.

By noon, we had laid 136 miles of cable, the Niagara having reach lat.  $52^{\circ} 11' 40''$  N., long.  $13^{\circ} 1' 20''$  W., and the depth of water having increased to 410 fathoms.

In the evening the speed of the vessel was raised to five knots per hour ; I had previously kept down the rate at from three to four knots for the small cable, and two for the heavy end next the shore, wishing to get the men and machinery well at work prior to attaining the speed which I had anticipated making.

By midnight 189 miles of cable had been laid. At four o'clock in the morning of the 10th, the depth of water began to increase rapidly, from 550 fathoms to 1750, in a distance of eight miles. Up to this time, seven cwt. strain sufficed to keep the rate of the cable near enough to that of the ship ; but, as the water deepened, the proportionate speed of the cable advanced, and it was necessary to augment the pressure by degrees, until, in the depth of 1,700 fathoms, the indicator showed a strain of fifteen cwt., while the cable and ship were running five and a half and five knots respectively. At noon, on the 10th, we had paid out 255 miles of cable, the vessel having

made 214 miles from shore, being then in lat.  $52^{\circ} 27' 50''$  N., long.  $16^{\circ} 00' 15''$  W. At this time we experienced an increased swell, followed late in the day by a strong breeze.

From this period, having reached 2,000 fathoms water, it was necessary to increase the strain to a ton, by which the rate of the cable was maintained in due proportion to that of the ship.

At six in the evening some difficulty arose through the cable getting out of the sheaves of the paying-out machine, owing to the tar and pitch hardening in the grooves, and a splice, of large dimensions, passing over them. This was rectified by fixing additional guards, and softening the tar with oil.

It was necessary to bring up the ship, holding the cable by stoppers, until it was again properly disposed around the pulleys. Some importance is due to this event, as showing that it is possible to lay to in deep water without continuing to pay out the cable—a point upon which doubts have frequently been expressed. Shortly after this, the speed of the cable gained considerably upon that of the ship, and up to nine o'clock, while the rate of the latter was about three knots by the log, the cable was running out from five and a half to five and three quarter knots per hour. The strain was then raised to twenty-five cwt., but the wind and sea increasing, and a current at the same time carrying the cable at an angle from the direct line of the ship's course, it was not found sufficient to check the cable, which was at midnight making two and a half knots above the speed of the ship, and sometimes imperilling the safe uncoiling in the hold.

The retarding force was, therefore, increased at two o'clock to an amount equivalent to thirty cwt., and then again, in consequence of the speed continuing to be more than it would have been prudent to permit, of thirty-five cwt.

By this the rate of the cable was brought to a little short of five knots, at which it continued steadily until 3.45, when it parted; the length paid out at that time being 380 statute miles.

I had up to this time attended personally to the regulation of the brakes; but finding that all was going on well, and it being necessary that I should be temporarily away from the machine, to ascertain the rate of the ship, and to see how the cable was coming out of the hold, and also to visit the electrician's room, the machine was for the moment left in charge of a mechanic, who had been engaged from the first in its construction and fitting, and was acquainted with its operation. I was proceeding toward the fore part of the ship, when I heard

the machine stop. I immediately called out to ease the brake, and reverse the engine of the ship; but when I reached the spot the cable was broken.

On examining the machine, which was otherwise in perfect order, I found that the brakes had not been released, and to this, or to the hand-wheel of the brake being turned the wrong way, may be attributed the stoppage, and the consequent fracture of the cable; when the rate of the wheels grew slower, as the ship dropped her stern in the swell, the brake should have been eased. This had been done regularly before, whenever an unusually sudden descent of the ship temporarily withdrew the pressure from the cable in the sea.

After the accident, the commanders of the vessels proceeded to Davenport at my request, the dockyard at Keyham affording many facilities for unshipping the cable.

At a subsequent discussion, the prudence of making a second attempt in October was considered, but the difficulty of obtaining sufficient additional line, and the uncertainty of the weather so late in the year, were cogent reasons against the adoption of such a course. It was, therefore, decided to store the cable until next summer, and (having been granted the use of a vacant space of ground by the government) four large roofed tanks were constructed to receive it.

The cable, which is in good condition, was discharged from the Niagara first, and has subsequently been unshipped from the Agamemnon. It has been passed through a mixture of tar, pitch, linseed oil, and bees-wax, in such consistency and quantity as effectually to guard against rust.

The buoys, chains, hawsers, and other stores and tools, are safely warehoused in the adjacent building.

Immediately upon the return of the expedition, steps were taken to recover such part of the cable laid from Valentia as could be raised so soon as the equinoctial gales might be over.

The Monarch, a steamer employed upon the submarine lines laid between Orfordness and the Hague, and fitted with the necessary appliances for picking up cables, was at first understood to be at our service for this work; but some delay to our plans for recovery arose from the fact, that at the time she was expected to be available, she was dispatched by the company to whom she belongs upon another duty, and it thus became necessary for us to procure and equip another vessel.

In the middle of October, I proceeded to Valentia with the Leipzig, a paddle-wheel steamer of a sufficient capacity; after some hindrance by the gales which prevailed at that time, fifty-



three miles of the small cable and four miles of the heavy cable were got up; the remainder of the shore-end was under-run, and is buoyed ready for splicing next year.

The sea and swell on that coast at this season are so unsuited to the work that the attempt to regain the remainder must be deferred for some weeks; but if the contract which has been accepted by you is successfully carried out, it will be more satisfactory as regards risk of outlay, than for us to renew the operation.

The recovered cable, which is in good order and fit for use again, has been delivered into store at Keyham.

Referring to the proposal to order a further length of three hundred miles of cable, in addition to the four hundred miles now in course of construction by Messrs. Glasse, Elliott & Co., I would observe that while I anticipate that the appliances suggested by experience will enable us to lay the cable this year with much less slack than is expected, I quite agree with the recommendation of your scientific committee that more allowance should be made for contingencies, in laying a line of such extraordinary length.

It is doubtless a circumstance much to be lamented in the past history of our undertaking, that the time within which it was intended to be completed did not permit of experimental rehearsals of various plans of cable-laying in deep water, respecting which there had been no previous successful experience.

“The result has been that experiment and practice have been mixed together in one operation; and hence, although all concerned actively in the undertaking are now fully alive to the means which will, in all human probability, secure success on the next occasion, yet great expense has been incurred without an adequate return, which might have been avoided had the needful time for experiment been available.”

The following is extracted from the report of Wildman Whitehouse, electrician of the Atlantic Telegraph Company:

“Placed, at very short notice, in the responsible post which he now holds, your electrician was called upon to examine into one of the latest and most difficult electrical problems of the day, involving considerations at once of the highest philosophical interest and of the utmost social and national importance. He was, moreover, pledged to achieve a practical success therein in the brief space of a few months; nor while engaged in this research could he for a moment be released from the equally important duty of personally superintending the manufacture, and testing the perfection and integrity of

the cable as it grew from day to day at the Gutta-Percha Works at Birkenhead and at Greenwich.

The examination of the former required the prosecution of an extended series of researches, and the construction of new instruments for the purpose of determining with accuracy the available force of the electrical current as tested at different distances, and for the investigation of the peculiar and hitherto practically most embarrassing phenomena of induction in submarine wires.

It was necessary, too, to approach the subject to a certain degree tentatively, and from time to time, as the increased length of cable admitted, to let our early telegraphic instruments grow with its growth and increase in strength or sensibility as the augmented distance required.

These indispensable researches naturally involved a somewhat considerable outlay in my department. They were not however, entered into without most careful consideration, and have been fully justified by the important and practical bearing of the results which they have been the means of bringing to light.

Notwithstanding my endeavors, circumstances conspired to limit the range of these researches, while the fact of the cable having been made at two distant places, rendered any full and satisfactory trial of instruments impossible, till the arrival of both vessels in Queenstown Harbor. That event was looked forward to with the most intense interest, as affording a brief and yet valuable opportunity, which, up to that time, had not been enjoyed by any scientific man, at once of proving the practicability of recording intelligible electric signals through a submarine conductor of the unprecedented length of 2,500 miles, and of trying on the extended scale the appliances for affecting this object, which up to that time had necessarily so far been constructed theoretically, as only to have been actually tried upon less than one half of the entire line intended to be worked by the Company.

On the arrival of the vessels at Queenstown Harbor, the earliest opportunity was seized of connecting the halves of the cable on board the two vessels, by a temporary line extended between ship and ship, in order that I might thus be enabled to test the instruments whose construction was based on the results of previous experiment on shorter lengths. In doing this I had the advantage of the assistance and co-operation of Professor W. Thomson, who is one of our directors.

These trials were made under every possible disadvantage of time, place, and circumstance; the connection between ship

and ship was imperfect, was interfered with inadvertently on several occasions, and was entirely destroyed at turn of tide.

The power of the instruments was found to be ample for the whole length of 2,500 miles; the signals received were even stronger than necessary, but the time required to elapse between signal and signal in order to avoid the blending of electric waves in the wire was considerable.

An extemporaneous arrangement by Professor Thomson and myself enabled us to transmit actual despatches in spite of these difficulties.

“Our experiments at Queenstown, therefore, successful though they were as furnishing a proof of the adequacy of the instruments to work through the whole distance, yet rendered it sufficiently evident that much time and attention might judiciously be bestowed upon these, as well as on the details and peculiar arrangements required for signaling through so vast and untried a distance, in order to attain a thoroughly certain and commercially satisfactory rate of communication.

On the sailing of the expedition we commenced our communication with the ship by the use of the lowest battery power sufficient to effect our object, in order to facilitate the detection of a fault or accident to the cable by those on board at the earliest possible moment after its occurrence.

An arrangement has been made by which, on the next occasion, on commencement from mid-ocean, either of the ships shall be able, at any and every instant during the voyage, to ascertain that all is right in her electrical connection with the sister ship, though it is not deemed desirable to endanger the safety of the Company's complete and special telegraphic apparatus by an attempt to keep up, by its use during the voyage, a constant interchange of messages from ship to ship.

Proceeding in the path which the light of experiment has opened up to us in relation to the differential values of conducting media, we have, in the additional length of cable now in process of manufacture, adopted the recent suggestion of Professor W. Thomson, and have instituted a series of tests for the conductivity of copper wire. Every hank of wire to be used for our conductor is tested, and all whose conducting power falls below a certain standard is rejected.

“We have thus secured a conductor of the highest value, ranging in conductivity from twenty-eight to thirty per cent. above the average standard of unselected copper wire.

It is but due to the Gutta-Percha Company to state, that, in their anxiety to advance the interests of submarine telegraphy to the utmost, they have afforded us every possible

facility in this laborious and important, but somewhat tedious and obstructive operation.

The arrival of the vessels at Plymouth, and the unshipment of the whole of our cable, to be stored there during the winter, afford the opportunity which I have so long deemed necessary, of submitting the working powers of our instruments to the most rigid tests through the whole circuit, under every conceivable condition. I have, therefore, with the sanction of the directors, removed thither the workshop, retaining a few of our most skilled hands for repairs and alterations of instruments, and the construction of any new ones deemed desirable. With these I have also removed our superintendent, and the whole staff of manipulators or instrument clerks, proposing to give them, during the winter, constant occupation in the transmission of actual dispatches through the whole length of the cable, thus rehearsing what will be the routine of their duties when our line is in operation.

The facilities afforded by the government authorities at the dockyard at Keyham have enabled me to fit up a complete telegraphic station here, in one of the buildings devoted to our use, in which the superintendent and staff of clerks are now constantly engaged in transmitting dispatches.

I have been able to examine most critically into the question of the highest speed of transmission attainable, carefully eliminating all mere instrumental or manipulative error from the results.

In doing this we have made use of an arrangement by which the accurate correspondence or otherwise of the transmitted with the received signal shall be most readily ascertained. The electric signals, *on their entrance into the cable*, are made to pass through an instrument, by means of which they record themselves upon the same slip of paper and side by side with those of the receiving instrument at the other or distant end of the line. We are thus enabled to scrutinize most closely the behavior and transit of every signal. If a dot or dash be lost, it is instantly detected; and if even the slightest discrepancy occur in the length of the relative marks, it cannot fail in this way to be at once made evident.

The power of our apparatus, as already made, is seen to be ample for the purpose; the speed with which it can be worked so as to insure accuracy in the transmission of a dispatch is found, however, to depend so greatly upon the steadiness and mechanical truthfulness of the manipulating clerk, that I have been induced to devise an addition to the transmitting part of our apparatus which shall render manipulative error almost impossible.

This apparatus, though as yet merely in an experimental form, has enabled me, without the use of additional electrical power, to obtain a very considerable increase in our speed, not only without any sacrifice, but with an absolute gain in the accuracy of transmissions.

By this means, and by the adoption of such an amount of abbreviation or code signals as we find it safe to use, we are now transmitting through the entire length of our cable dispatches at the rate of four words in a minute.

I cannot refrain from an expression of the real gratification which the attainment of this step has afforded me,—the more so as I feel justified thereby in anticipating still further progress and higher results;—nor need I point out the direct and positive bearing of this question upon the commercial success of the company.”

#### THE FIRST EXPEDITION OF 1858.

Early in June the vessels proceeded to the deep sea in the vicinity of the Bay of Biscay, on an experimental expedition to test the machinery for the laying and drawing in of the cable. Three days were thus employed, and the results were pronounced as satisfactory.

On the tenth of June the telegraph squadron sailed from Plymouth for mid-ocean, where it had been determined by the company to commence the submerging of the cable, instead of the Irish coast, as had been adopted in 1857. The point in mid-ocean where the vessels expected to meet and unite the cable was lat.  $52^{\circ} 02'$ , long.  $33^{\circ} 18'$ .

Each vessel had 1,500 miles of cable on board. It was intended that the Niagara should proceed from the point of junction to the Newfoundland coast, and the Agamemnon was to proceed to the coast of Ireland.

On the 26th of June the splice was made and the respective vessels proceeded on their mission. The vessels had proceeded but a short distance when the cable, becoming entangled in the machinery, broke. Some six miles of cable were lost in the sea. The break was immediately discovered on board the Agamemnon. Both vessels returned and a new splice was forthwith made. The ships again proceeded to lay the cable. On Sunday, the 27th, the continuity of the current was found to be broken when some 42 miles of the cable had been paid out. The cause of the interruption of the electric current was never discovered. The vessels again returned to the rendezvous, and on the 28th another splice was made, and soon thereafter they were under way. The paying out continued with

complete satisfaction until 142 miles of the cable had been submerged, when it broke near the stern of the *Agamemnon*. Up to this time there had been lost in the three efforts 190 miles.

The vessels, failing to meet again in mid-ocean, returned to Queenstown for further arrangements to be adopted in the premises.

#### THE SECOND EXPEDITION OF 1858.

The company having determined to make another attempt to lay the cable in 1858, the vessels again proceeded to mid-ocean, where they united the ends on the 29th of July, 1858.

The paying out was continued successfully until 7 45 p. m., when the signals ceased; fortunately, however, communication was again restored some two hours thereafter. Like interruptions occurred several times during the voyage, and no satisfactory explanations in regard to them have transpired.

On the 5th of August, at 1 45 a. m., the *Niagara* anchored in Trinity Bay, Newfoundland. The distance run by the *Niagara* was 882 miles, and the amount of cable paid out was 1,016 miles. At 5 15 a. m. the end of the cable was landed on shore.

On the 5th of August, at 6 a. m., the *Agamemnon* anchored opposite Valentia, having laid 1,020 miles of cable. At 3 o'clock p. m. the end was carried on shore.

#### WORKING OF THE ATLANTIC TELEGRAPH CABLE.

In regard to the working of the cable, but little has been made public. The batteries employed to work it consisted in the first instance of induction coils known as Ruhmkorff's, but in a modified form, excited by a Smee battery. Subsequently the ordinary Daniell battery was adopted. The instrument used at the Newfoundland end was a delicate electrometer, and at the Valentia end Professor Thomson's reflecting electrometer.

To what extent communication has been transmitted over the cable the public has not been informed. I have, however, learned from reliable sources that the maximum speed of intelligible and unintelligible signals transmitted and received over it were at the rate of one wave for each three and one third seconds. It was announced that a message from the Queen of Great Britain was received over the cable for the President of the United States, on the 16th of August, eleven days after the cable had been landed on the Newfoundland and Irish coasts. On the evening of the 16th a paragraph containing

about one third of the message was presented to the President and the public as the whole dispatch, but on the 17th the remainder was published, with the following explanation :

ST. JOHNS, N. F., *August 17.*

Mr. De Sauty, the electrician-in-chief at Trinity Bay, says that he is unable to give any information for publication as to the working of the cable, but that the time necessary for the transmission of the President's Message depends on its length and the condition of the line and instruments at the time—perhaps, under favorable circumstances, an hour and a half.

The reception of Queen's Message was commenced early yesterday morning, and not finished until this morning, but it was stopped for several hours to allow of repairs to the cable. The fragment of the message transmitted yesterday was handed to the Newfoundland line as the genuine entire message, and was supposed to be such until this morning.

Another publication estimated that the time required for the transmission of the message was about 20 hours. It contained about 100 words.

In regard to this subject, the following extracts of a letter was published in the London Morning Post of August 18th :

*To the Editor of the Morning Post :*

SIR : I have the pleasure to inform you that the line from Valentia to Newfoundland is now working satisfactorily both ways. The following message was dispatched yesterday evening from the Directors in England to the Directors in America :

“Europe and America are united by telegraph. Glory to God in the highest, and on earth peace, good will toward men.”

This message, including the addresses of senders and receivers, occupied 35 minutes in transmission, and consisted of 31 words. Immediately afterward a message from her majesty the Queen to his excellency the President of the United States, consisting of 99 words, was received by Newfoundland in 67 minutes. Both messages were repeated back to Valentia to test their accuracy, and were found to be taken with great exactness. Of course, unless permission was given, the contents of her majesty's dispatch cannot be made public.

It will thus be seen that the line is now capable of being worked with perfect accuracy, and the company will now proceed, as rapidly as is consistent with the establishment of a proper system, to make the necessary arrangements for opening

the communication to the public; in doing which, however, some delay must necessarily occur.

Yours truly,  
 GEORGE SAWARD,  
*Secretary and Manager.*

*Chief Office, 22 Old Broad-street,*  
 LONDON, August 17.

The signals over the cable continued to grow feebler until the 1st of September, when nothing intelligible could be received. Since that time all efforts to operate it have failed. The failure of the cable to operate successfully, as had been announced by the company, fell upon the world with surprise and profound regret.

The successful laying of the cable across the ocean had been hailed by the roar from thousands of guns, by the shouts of joy throughout the land, by the chiming of bells in the sacred spires, and songs of praise were heard on hill and in dale. It was but natural that the failure of the cable to work successfully, after it had been stretched from hemisphere to hemisphere, should produce in the minds of men more than an ordinary astonishment.

#### CAUSE OF THE FAILURE OF THE CABLE TO OPERATE.

As soon as the company in London ascertained that the cable had failed to communicate intelligible signals, energetic efforts were made to ascertain the cause, having in view the remedying of the difficulty. To that end, Mr. C. F. Varley, the very able electrician of the International Telegraph, was dispatched to Valentia, and subsequently, was Mr. W. T. Henley, a distinguished electrician, of London. Through the kindness of the energetic secretary of the company, Mr. Seward, I am enabled to present the reports of those gentlemen to the reader. They contain scientific information very valuable to submarine telegraphers.

#### *Report on the State of the Atlantic Telegraph Cable.*

LONDON, Saturday, Sept. 18.

I arrived at Valentia on the evening of the 5th inst., when I found that no words had for many days been received through the cable from Newfoundland.

On the 6th, 7th, 8th, 9th and 10th, I tested the cable at intervals in four different ways to ascertain its condition. The following are the results:

1. There is a fault of great magnitude at a distance of between 245 and 300 statute miles from Valentia, but the local-



ity cannot be more accurately ascertained until a portion of the cable, 20 or 30 miles in length, has been tested against my standard of resistance, and until the log has been consulted to ascertain the amount of slack paid out. I would suggest that the piece of cable at Greenwich be carefully measured and tested against my standard, in order to obtain the most correct estimate of the distance of the fault. Assuming, however, that it is 270 miles, and allowing 22 per cent. for slack, it is possible that the chief defect is in shallow water—410 fathoms.

2. The copper wire at the faulty place above alluded to does not touch the iron covering of the cable, as is proved by its forming a voltaic element, which gives rise to a continuous positive current from the copper wire varying very little in tension.

3. The insulation of the wire between Valentia and the fault, is perfect, or at least contains no defect of sufficient importance to be perceptible, or to materially influence the working were the cable otherwise perfect.

4. The copper wire is continuous, and consequently the cable has not parted. Faint signals, or reversals, are still received from Newfoundland, but the power used will shortly eat away the exposed copper wire in the faulty place by electrolytic decomposition.

The actual resistance of the fault appears to be at least equal to ten miles of the cable, but is most probably greater.

Taking it at its lowest resistance, viz., ten miles, and assuming that Newfoundland is only using 180 cells of Daniell's battery, the strongest current received thence during my stay was only a 24th part of the force that it should be were there but this one fault. When it is, however, borne in mind that on the other side they are probably using more power, and also that the defect first alluded to probably offers more resistance than that assumed, viz., ten miles, it is evident that there is another and more distant fault, the approximate locality of which I could not pretend to estimate at this end without being able to speak to Newfoundland.

From authentic *data* shown to me at Valentia, I am of opinion that there was a fault on board the *Agamemnon*, before the cable was submerged, at a distance of about five hundred and sixty miles from one end, and six hundred and forty from the other.

The following are the *data* in question, but on what occasion they were obtained, I am unable to state. They were, however, probably taken when the ships were at Queenstown :

*Testing of Coils on board the Agamemnon, consisting of about twelve hundred statute miles of Cable.*

1. When the upper end was disconnected, the current entering the cable from a battery, was..... 8.5 parts.
2. When upper end was put to earth, current entering the cable was..... 10.5 parts.
3. Current going out of upper end of cable to the earth..... .5 parts.
4. When the lower end was disconnected, the current entering the cable was..... 8.5 parts.
5. When lower end to earth..... 10.5 parts.
6. Current going out of upper end of cable to earth..... 4.5 parts.

Showing that, if there were a fault, it was nearer to the upper end, but not far from the middle of the coil.

When 200 miles had been removed from one end of the coil, (but from which end I am not at present aware,) leaving 1,000 miles, the amounts were :

|        |              |  |        |             |
|--------|--------------|--|--------|-------------|
| 1..... | 7.5 parts.   |  | 4..... | 8.5 parts.  |
| 2..... | 10.25 parts. |  | 5..... | 11.5 parts. |
| 3..... | 6.5 parts.   |  | 6..... | 6.5 parts.  |

Indicating that there was a fault, by rough calculation, at about 560 miles from one end, and 440 from the other.

With the 200 miles of cable amounts were :

|        |             |  |        |             |
|--------|-------------|--|--------|-------------|
| 1..... | 2 parts.    |  | 4..... | — parts.    |
| 2..... | 40 parts.   |  | 5..... | 40.5 parts. |
| 3..... | 39.5 parts. |  | 6..... | 39.5 parts. |

*Test of the entire Cable on board the Agamemnon and Niagara—viz., twenty-five hundred miles.*

BATTERY AT AGAMEMNON END.

1. Current entering the cable, the Niagara end being disconnected..... 45 parts.
2. Niagara end to earth ..... 49 $\frac{3}{4}$  parts.
3. Current flowing out at Niagara end to earth.. 15 $\frac{1}{4}$  parts.

BATTERY AT NIAGARA END.

4. Current entering cable, Agamemnon end being disconnected..... 35 $\frac{3}{4}$  parts
5. Agamemnon end to earth..... 37 parts.
6. Current flowing out at Agamemnon end to earth..... 14 parts.

Indicating considerable leakage on board the Agamemnon.

I am also informed that the currents through the cable, even immediately after it was submerged, were so weak that relays were useless, and that not one perfect message was recorded by them, everything that was received being read from the reflections of a galvanometer.

By comparing the above *data* with those of the new cable now making by Messrs. Glasse and Elliott, for the Electric and International Telegraph Company, the amount of current which entered the 1,000 miles of cable when disconnected at one end should not have exceeded 2 or 2.5 parts, instead of 7.5 and 8.5 parts.

The inference by rough calculation, therefore, is that there was a fault offering a resistance equal to 1,000 or 1,200 miles of cable, situated at a distance about 560 miles from one end of the 1,200 mile coil on board the *Agamemnon*.

This, however, cannot be the fault first alluded to, situate at about 270 miles from Valentia, but may have been the one which caused such alarm when the ships were 500 miles from Ireland, and when the signals ceased altogether and never certainly recovered.

It is not at all improbable that the powerful currents from the large induction coils have impaired the insulation, and that had more moderate power been used, the cable would still have been capable of transmitting messages.

To satisfy myself on this point, I attached to the cable a piece of gutta-percha covered wire, having first made a slight incision in the gutta-percha to let the water reach the wire; the wire was then bent so as to close up the defect. The defective wire was then placed in a jug of sea water, and the latter connected with the "earth." After a few signals had been sent from the induction coils into the cable, and, consequently, into the test wire, the electricity burnt through the incision, rapidly burning a hole nearly one tenth of an inch in diameter.

When the full force of the coils was brought to bear on the test wire by removing them from the cable, and allowing the electricity only one channel—viz., that of the test wire, the discharges, as might be expected, burnt a hole in the gutta-percha under the water, half an inch in length, and the burnt gutta-percha came floating up to the surface.

The foregoing experiments prove that when there are imperfections in the insulating covering, there is very great danger arising from using such intense currents.

The size of the present conducting strand is too small to have worked satisfactorily even had the insulation been sound.

With a strand of larger dimensions less intense currents would be required, and both speed and certainty increased.

It is not, however, altogether impossible that some intelligible signals may yet be received through the cable, as stated in my previous communication.

C. F. VARLEY,

*Electrician of the Electric and  
International Telegraph Company.*

On the 5th of October, 1858, Mr. George Seward, the Secretary of the Company, officially authorized the publication of the following report in the London Times :

*To the Chairman and Directors of the Atlantic Telegraph  
Company:*

VALENTIA, Sept. 30, 1858.

GENTLEMEN: In accordance with your instructions, I have, since my arrival here on the 8th instant, carefully tested the cable at various times, and with different degrees of battery power, and have found its insulation seriously impaired, and the results of the testing led to the conclusion that the injury is at a considerable distance from this (very nearly 300 miles of the cable apparently intervening between this point and the fault).

As I think it right you should know on what grounds and by what modes of operation I and others have arrived at this conclusion, and as you may also like to be informed as to some of the phenomena of electrical science as shown in connection with this cable, I have ventured to go a little into detail, hoping thereby to convey some information that may not be unacceptable.

On connecting one pole of a voltaic battery with the end of the cable with a galvanometer in circuit, and the other battery pole to earth, I find the current meets a resistance to its passage equal to two hundred and ninety miles of the copper conducting wire of the cable, and as the cable is more than two thousand miles long, it is therefore evident that the greater part of the current finds a shorter route to the earth.

By resistance is meant the impeding force that electricity meets with in its passage through conductors of all kinds, metallic or otherwise, and which varies immensely, not only in various metallic and other bodies, but also in the same kind of metal, and this can be accurately measured even in one inch of wire. Taking any given metal, the conductivity of which

is uniform, the resistance of the wire will be found to increase as the size decreases, exactly in proportion to the sectional area. A mile of No. 40 copper wire is thus found to resist as much as 175 miles of the conducting wire of the Atlantic cable. It is necessary also that the fine wire should have been previously tested with some of the cable, as wires of the same gauge are frequently found to vary very much in size as well as in conductivity. Knowing the resistance per yard of the fine wire, to obtain that of the cable comprised between the point of operating and the fault (and thus to find its length), the battery and galvanometer are connected with the line and earth in the before-mentioned manner. The degrees of deflection are accurately read on the galvanometer, and this process is repeated several times with batteries of different degrees of strength; the batteries and galvanometer are then disconnected from the cable and earth, and connected with coils of fine wire, the length of which latter is added to or diminished until the readings of the galvanometer exactly coincide in every case with those noted when connected with the cable. The length of the fine wire will then give that of the cable up to the point at which the battery current finds earth, reckoning about one mile of cable for every 10 yards of wire. There are several methods of doing the same thing, but they are all based on the same system of proportionate resistances.

There is next the resistance of the fault itself to be taken into account, for, strange as it may appear to some, faults (in proportion to their magnitude) may be equal in resistance to from one mile to several hundreds of miles of cable, and would give the same indications on a testing instrument. If we knew the exact nature of the injury, and how much of the copper was exposed, we could, with tolerable certainty, tell at what distance it existed; but in the absence of such knowledge we must judge from appearances, making use of any previous experience we may have had in matters of a similar kind. And, firstly, we know if much of the resistance was produced by the fault, it must expose a very small amount of surface, and that on sending positive currents, the wire (by electrolytic action) would be oxydized at the faulty spot, and the galvanometer would show that the fault was partially repaired by the non-conducting power of the oxyde.

On reversing the direction of the current, hydrogen would be evolved, which, by reducing the oxyde and cleaning the wire, brings the fault back to its former state. Should it be of considerable size, and consequently of small resistance, the coat of oxyde would be thin, and quickly reduced by reversing

the current, showing that very little alteration was produced by changing its direction.

Precisely this effect is produced by sending currents into the cable, indicating the injury to be of that character. A small fault could not reduce the strength of the signals to the extent we find them, unless the wire was separated near that point, and this (which is quite within the range of probability) would set our calculations at naught. That the cable is not severed we have abundant proof, but that any one can, by the most delicate tests, discover whether the conducting wire is so or not in a cable of this length I utterly deny. Should such be the case, it does not follow that the line must be rendered useless, as I have known underground telegraphs to work for months after the conducting wires had been separated more than a quarter of an inch by the decomposing power of the batteries employed. A slight failure existed in the gutta-percha; this admitted moisture, which, by conveying the electricity to the earth, caused the decomposition of the wire, and then aided the working of the telegraph by conducting a portion of the current from one point of the separated wire to the other. Signals were much reduced in power, as in the present case; still the wire continued to work, and if such can be done for months, it might happen for a longer period.

If, by any means, the conducting wire separates, and the gutta-percha remains sound, all communication ceases, from the absence of moisture to complete the circuit. By our testing, one fact is unquestionably established, and that is, the fault is not beyond 300 miles. I speak of the great fault; others may exist between that and Newfoundland, but if it be a fact, as I have heard, that, on testing at the latter place, very little earth is shown, the probability is that the other part of the cable is good. Having arrived at the fact of the injury not being beyond 300 miles, the difficulty is to know how much within that distance it is to be found, or how much of the resistance is due to the cable, and how much to the fault; and although by accurate testings and examinations a pretty correct knowledge of the facts may be obtained, still it is liable to some uncertainty, and instances have occurred in testing cables where the most experienced have been quite wrong in their conclusions.

I cannot think it possible for the injury to be in the harbor, but should think it advisable to lay down some length of shore end, as the cable near the land must soon be injured by friction on the rocks and shingle. A piece of the same size,

laid across the harbor for the Magnetic Company, was entirely worn asunder some days since.

In my opinion the fault or faults existed in the cable before it was submerged, and that they would have been detected and made good had the precaution been observed of having the whole cable tested in water during its manufacture.

Its not showing so bad when first laid is easily to be accounted for, as it takes some time for the water to soak through the coating of pitch and tar. In a cable I am now manufacturing a fault was four days in the water before showing anything.

Had your cable been injured after submersion by resting on the sharp edge of a rock, the inner wire and the outer metallic covering must have come in contact, and that this is not the case we have absolute proof, both from the fact of a battery current being generated by the iron sheathing and the exposed copper, and from signals being received from Newfoundland; for, did the iron touch the copper conductor in the smallest point, not the slightest signal could be observed. Signals were from the first much weaker than they ought to have been from a tolerable insulated line of that length, and were scarcely sufficient to work a very delicate relay, which can be used with a current so feeble that it could only just be detected on the tongue. The currents now received are not more than a tenth of that power, and can only be indicated on Professor Thomson's very ingenious reflecting galvanometer. This is constructed on the principle of the boys' "trick" of receiving the rays of the sun on a piece of looking-glass and reflecting them on the wall, a very small motion of the hand giving a range of many feet to the spot of light. Professor Thomson attaches a small mirror to the magnetic needle of a very delicate galvanometer of his own contrivance; the light of a lamp is thrown on the mirror, and a motion of the needle that would be inappreciable in itself is plainly indicated by the reflected spot of light on a scale. The apparatus could be made much more delicate still, and capable of working with the smallest amount of current, but there is an obstacle in the way of using such a feeble power, and that is the earth current, which shows itself at all times more or less.

If this earth current were at all constant in its quantities or direction, it would be quite easy to compensate for it and render its effects neutral; but it is most erratic in its movements, sometimes throwing the spot of light entirely off the scale, at others changing from positive to negative and back again so rapidly and frequently, and with such regularity that

it is difficult to know whether it is Newfoundland or the earth current signaling.

These earth currents in submarine and subterranean lines (like the atmospheric currents, as they are termed in overground wires) are produced by the inductive effect of natural currents of electricity moving parallel with the conducting wires, it being a well-known law of electricity that if a current moves in the vicinity of a wire or other insulated conductor, a current is set up in each wire in a contrary direction, its strength being in proportion to the parallelism of the wire with the natural current.

Any wire laid parallel with the equator, or nearly so, will have also its electrical condition disturbed by every variation in the earth's magnetism. On the first establishment of practical telegraphy, the inconvenience experienced from these currents was as annoying as it was unexpected, but in course of time contrivances were produced capable of modifying or counteracting their effects, so that but little trouble is now felt from their occurrence; although even now occasionally on some lines all communication is stopped for a short time when these terro-magnetic currents are unusually strong. On lines of 100 miles or so they only show themselves at intervals. At other times the line is quite free; but on a line of such enormous length as the Atlantic cable, electric disturbance is sure to take place on some part of it at all times; and if a current is set in motion in any part, the effect is communicated throughout the whole. In another cable (as well as in this had its insulation been more perfect) earth currents would not cause much trouble, as the working currents sent through the line would not lose their strength, as in the present case, and consequently would overpower them.

The mere resistance of the cable as regards its length would offer very little impediment to its working. The same length of insulated wire, stretched on dry earth or other non-conductor, could be worked through with a very small power and at a rapid rate. It is only when it becomes surrounded by a conductor, such as damp earth or water, or by the metallic covering of the cable, that the phenomena of induction again come into play, and the more complete the insulation the greater will be the embarrassment from induction.

The effect of this is shown when a battery is connected with the line and earth, or outside of the cable. The inner, or conducting wire, becomes charged or electrified *plus*; the outer coating *minus* (similar to a Leyden jar). When the ends are put to earth the effect goes off, but not instantly, and when the



two electrified media are so far removed, as in a line of 2,000 miles, if connected with the earth, a very considerable time is occupied both in charging and discharging, causing much retardation of the current, so that I think four words per minute will be the maximum rate of transmission through any Atlantic cable with the present dot and dash system. If other plans can be worked by which a letter would be indicated by one or two signals, the rate would be increased in proportion.

As I have made use of the terms resistance and retardation, and as they are words having different meanings, I will explain what constitutes the difference. The "resistance" of a wire has the effect of keeping part of an electric current back, or diminishing its quantity, without affecting its velocity, the remainder passing as quickly as it would through a wire of the same length with less than a hundredth part of the resistance. The effect of "retardation," on the contrary, is to diminish both the quantity and velocity of the current. For example, in an overground well-insulated wire, 2,000 miles long, an electric current or impulse would traverse the entire length in one tenth of a second; through the same extent of submarine line, owing to the effect of the charge, the time occupied would be nearly a second and a half.

Respecting the question of injury to the line from the use of powerful currents—if a small hole leading to the wire exists in the gutta-percha covering near either end, there is no doubt that a current of great quantity and intensity, whether produced by battery or coils, would have the effect of enlarging the breach by burning; but this can only take place to a limited extent. Heat can only be developed by an electric current when the latter meets with great resistance; consequently, as soon as that is diminished by a slight enlargement of the hole, all burning ceases. I tried the experiment alternately with the large induction coils, with the battery now here (400 cells of Daniell's) and with my large magneto-electric machine. They were each connected in turns with the line and the earth, and at the same time with a piece of gutta-percha-covered wire, in which the copper was bared to one thirty-second of an inch diameter, and a piece of copper in a basin of sea-water, thus dividing the current between the two routes. The coil current enlarged the fault to one twentieth of an inch in diameter; the batteries to a sixteenth—both very slowly. That from the magneto-electric machine made no change in the fault it was applied to until it was disconnected with the line and earth, and allowed the one road only; when burning took place, as might have been expected. The

fault was enlarged very slowly to one tenth of an inch. On repetition with the coils, the fault was increased to one tenth diameter, and with the batteries to one sixth, rapidly with both. No further burning can take place with either current till the wire is brought to the surface of the water, when, owing to the resistance increasing, by the fault being only partly immersed, the burning commences anew and the gutta-percha inflames.

On the arrival of my large magnetic machine, I put it together, and connected it with the cable, and have used it a part of every day since, sending at some times reversals and at others words and sentences. I am unable to tell whether they were received and understood, but hope to find such has been the case on the receipt of intelligence from Newfoundland. Having a machine at one end only, it will, of course, be evident that, even if they received properly, they could not have answered better than before. But we have been encouraged by seeing more reversals and attempts to send words from them lately than before. I will leave the machine here; it will be worked at stated hours each day by the assistants until the days fixed upon in October, when it will be used alternately as arranged with the battery and coils. The clerks at each end will then act according to preconcerted arrangements, which I hope will have the effect of renewing telegraphic correspondence. If that is not accomplished, probably the best thing then would be to raise the cable for about 15 miles out and test. I cannot say I have any hopes of the fault being found within that distance, but as it would not be attended with any trouble or risk I think it worth the trial. If the injury is in the deep soundings, I believe any attempt to raise it would be the means of breaking the cable and losing the end altogether. If the state of the cable should not get worse I am still in hopes of its being rendered workable by transmitting signals slowly, by having delicate receiving apparatus, and by adopting means for neutralizing the earth current. Professor Thomson has partially succeeded in the latter object by throwing into the receiving end of the line feeble currents of different values, from one cell to one twentieth of a cell, in opposition to the earth current.

I am, gentlemen, yours obediently,

W. T. HENLEY, *Telegraph Engineer.*

46 *John-street-road, Clerkenwell.*

Various trials have been made to work the cable since the report of Mr. Henley was submitted, but without success. The company has exerted itself to make available the great enterprise, but thus far, sadly to be recorded, in vain.

This stupendous enterprise was started and executed with great energy and skill. The account current of the company up to December 1, 1858, exhibited an aggregate expenditure of £379,029. The governments of Great Britain and the United States loaned the vessels employed in 1857 and in 1858, by which the finances of the company were materially benefited. The governments, also, had agreed to pay an annual subsidy upon certain conditions for a term of twenty-five years. The colonial governments in America had also granted certain immunities for the benefit of the undertaking. In a word, the company had lavished upon it every consideration to enable it to effect the most signal triumph. Every effort within human power was directed toward the consummation of success; but, how to make the cable work effectively for commercial purposes, was something beyond the reach of man, and known only to the Supreme Being.

At the present time it has not been determined when another attempt will be made to connect the New and the Old World by telegraph.

In the meantime, other companies are being organized for the submerging of cables on other routes, one of which is proposed to run from England or Portugal to the Azores, and thence to the United States, on which route the longest circuit will be about 1,400 miles; and another project is to run a line *via* the Faroe Isles, Iceland, and Greenland, to Labrador, the longest circuit on which line will be about 500 miles. There can be no doubt but what cables can be laid on any and all the routes projected across the ocean; but to practically work them after they are laid for commercial purposes, is a problem not yet solved. We can, however, indulge the hope that some new discovery may be made in the science of electricities that will enable the world to realize the most complete consummation of the great desideratum, which was, for a time, supposed to have been accomplished on the submerging of the late Atlantic cable between the coasts of Ireland and Newfoundland.

It is a singular coincidence that the first feat of telegraphing was executed by order of King *Agamemnon* to his queen, announcing the fall of Troy, 1084 years before the birth of Christ, and that the last great feat was executed by the ship *Agamemnon* in the landing of the Atlantic cable on the coast of Ireland, 5th of August, 1858.

# OCEAN TELEGRAPHY.

---

## CHAPTER XLV.

The Depths of the Ocean—Description of the Brooks Lead—The Elements of the Ocean—Maury's View of a Deep Sea Cable—Atlantic Telegraphs Projected.

### THE DEPTHS OF THE OCEAN.

THE submerging of a telegraph cable in the deep sea, is an affair of no ordinary magnitude. Ever since the American government so triumphantly, reached the bottom of the ocean with a lead, and brought to the surface the treasures that have laid there undisturbed, perhaps, since the world began, I have been satisfied, that a cable might be laid upon the bottom of the mighty deep, in most any direction, from hemisphere to hemisphere.

Since then, cables have been laid across the British channel, the gulf of St. Lawrence, the Mediterranean sea, the Black sea, and lastly, the great Atlantic ocean, from Ireland to Newfoundland. The experience the world has in relation to the submerging of a cable in the deep seas, gives confidence in the feasibility of laying a cable across any ocean, however deep, or in whatever latitude.

From time immemorial, the world has tried to fathom the depths of the sea. Various contrivances have been invented and experimented upon, but without success. The ocean bed remained as a sealed volume—an unsolved problem.

Nations, and men of science, of all ages, have endeavored to interpret the mysteries of the sea. Book after book has been written upon the probable contour of the bottom; but all these were mere speculations, based upon comparisons with developed nature. Finally, the long desired light burst forth, and spread its rays, diffusing fresh knowledge throughout the world. The honor had been reserved to America, to conquer the wave, and descend to the blue depths of the restless ocean

Fig. 1.

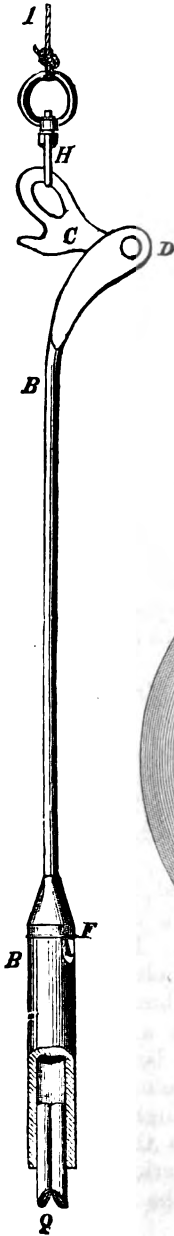

Fig. 2.

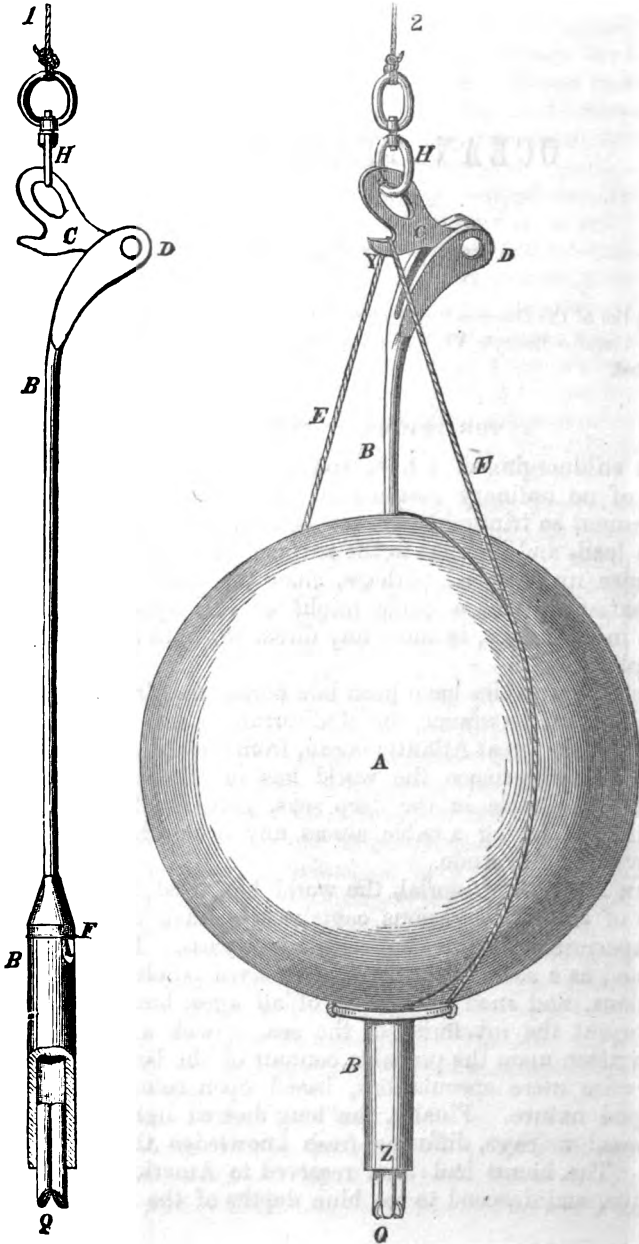
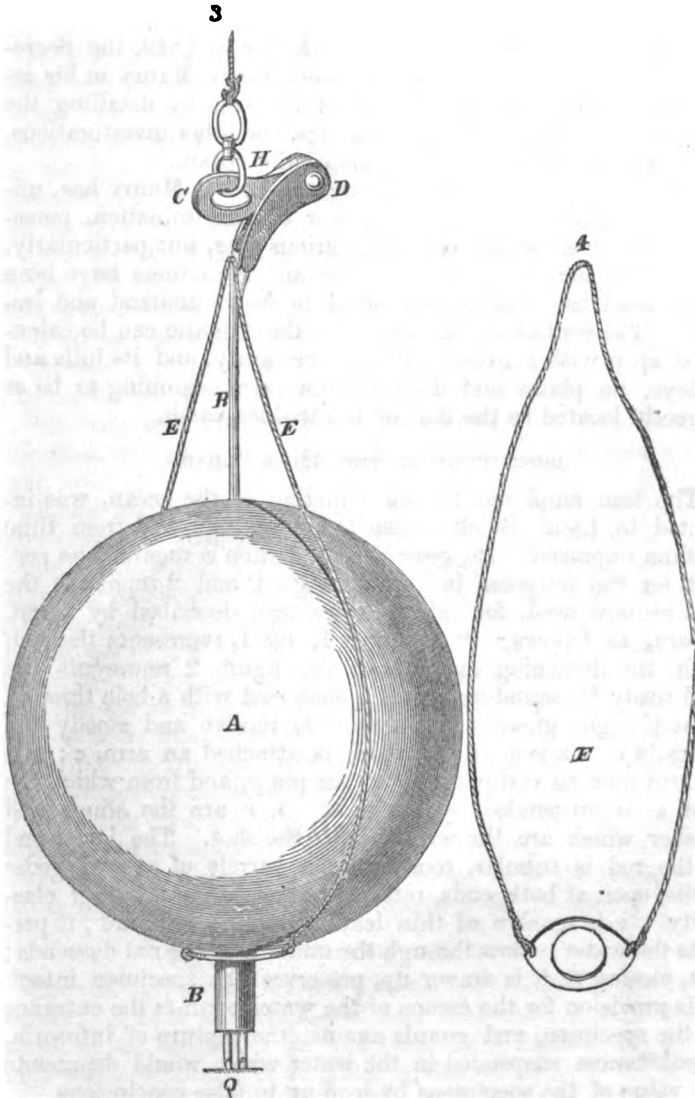

Fig. 3.



and grasp its bottom for the most minute inspection. To the energetic labors of Lieut. M. F. Maury, Superintendent of the National Observatory, and to Passed Midshipman J. M. Brooks,

the inventor of the deep sea lead, both of the United States Navy, great honor is due for the success attained in fathoming the great depths.

By an act of Congress, approved March 3, 1849, the Secretary of the Navy is directed to assist Lieut. Maury in his researches concerning the physics of the sea, by detailing the vessels of the navy to make soundings, and other investigations, relative to the winds and currents of the ocean.

Conformably to this act of Congress, Lieut. Maury has, unceasingly and with singular power of discrimination, persevered in the investigation of the various seas, but particularly, the greater part of the Atlantic ocean. Soundings have been taken from the equator, and north to Newfoundland and Ireland. The contour of the bottom of the Atlantic can be calculated upon with a great degree of certainty, and its hills and valleys, its plains and deep caverns, are beginning to be as correctly located as the face of the trodden earth.

#### DESCRIPTION OF THE BROOKS LEAD.

The lead employed for the sounding of the ocean, was invented by Lieut Brooks, some ten years ago, and from time to time improved. Its present combination is regarded as perfect for the purposes in view. Figs. 1 and 2 represent the lead as now used, for taking soundings, described by Lieut. Maury, as follows: "Numeral 1, fig. 1, represents the rod, with the detaching apparatus; and figure 2 represents the lead ready for sounding. A is a shot, cast with a hole through it, and slight grooves on its side, to receive and steady the slings, E E. B is a rod, to which is attached an arm, c; c is an arm moving vertically about the pin d, and from which the shot A is suspended by slings E. E E are the slings and washer which are thrown off with the shot. The lower end of the rod is tubular, receiving the barrels of several goose quills, open at both ends, retaining their places by their elasticity. F is a valve of thin leather opening outward; it permits the water to flow through the quills 2, as the rod descends; but, closing as it is drawn up, preserves the specimen intact. This provision for the escape of the water permits the entrance of the specimen, and guards against the capture of infusoria, or substances suspended in the water which would depreciate the value of the specimens by leading to false conclusions.

The proportions of this instrument are such, that when the shot is suspended from the arm c, the point of contact x, the point of suspension y, and the point of resistance z, all lie in the same vertical line; the weight of the rod, B, will then give

the arm, *c*, a slight inclination, which, with the friction of the water on the line, holding it back, guards against premature detachment.

It is obvious that the sensitiveness of this detaching apparatus, will depend upon the relative positions of those three points; for the arm, *c*, may be regarded as a lever of the second order with its fulcrum at *d*; the gravity of the shot as the power acting upon the resistance of the line. So that, by increasing or diminishing the distance of the ring, *n*, from the pin, *d*, the detachment is rendered more or less difficult.

In order that change of position in the arm, *c*, as it yields to the pull of the shot in the act of detaching, may not interfere, it is so made as to permit the ring to slip back as the arm inclines, as shown by fig. 3.

On soft bottom it should work as well as on hard, for it is only necessary that there shall be a retardation of the descent of the rod, while the heavier shot continues to descend into the mud, to cause the turning of the arm and discharge the shot.

Before using the instrument, the operator may test its sensitiveness and adapt it to the depth of the water; in deep sounding, it should be so delicately adjusted, as to act upon the slightest touch, and should be eased down for the first fifty fathoms, or more.

The quills, *q q*, are cut as per figure, and are placed with the cut ends downward, and then several of them are wedged into the cell or holder. The advantages of this arrangement are, we have more abundant specimens than an ordinary arming will bring up, and then we have the gratification of having them properly examined by the microscope."

With this lead the deep sea has been fathomed, and its bottom exposed to man, and upon its examination by the microscope the supposed earth has been found to be the remains of the minute inhabitants, or the organisms of the sea.

#### THE ELEMENTS OF THE OCEAN.

On the subject of Ocean telegraphy, Lieut. Maury thus writes: "It is an established fact that there is no running water at the bottom of the *deep* sea. The agents which disturb the equilibrium of the sea, giving violence to its waves and force to its currents, all reside near or above its surface; none of them have their home in its depths. These agents are its inhabitants, the moon, the winds, evaporation and precipitation, with changes of temperature—such as heating here, and cooling there.



The rays of the sun cannot penetrate into the depths of the ocean, and radiation cannot take place thence; consequently, the change of the temperature in the depths of the sea, from summer to winter, and winter to summer, must be almost, if not entirely, inappreciable. This is a generally admitted fact.

The winds take up water from the surface, and not from the depths, and in so doing, they disturb the equilibrium of the water at the top, not the equilibrium of the water at the bottom; by evaporation, the water becomes saltier and heavier than it was before, the vapor thus taken up is condensed into rain and precipitated on other parts of the sea—thus both raising the sea level, and making the water lighter and less salt than it was before. Thus we have the genesis of horizontal circulation, or an interchange of water called currents. If by the process of evaporation, the surface water becomes so salt as to be heavier than the water at the bottom, the water at the bottom and water at the top will change places. This may give rise to a vertical circulation, but one so feeble that it cannot be felt, by even the tiny little shells which strew the bed of the ocean, and which lie there as lightly as gossamers under the dew of the morning; practically, therefore, the water at the bottom is still.

It is also generally admitted that the waves, even in their most angry moods, are incapable of reaching far down in the sea, or of disturbing the quiet and repose which reign in its depths.

In short, there is reason to believe, that the bottom of the *deep* sea is everywhere protected from the violence of its waves, the abrading action of its currents, and the rage of the forces which are ever at play on its surface, by a cushion of still water.

The grounds for this belief are afforded by these circumstances: everywhere, whencesoever specimens of bottom have been obtained by the deep sea plummet, they have been found to consist of the untritured remains of the microscopic organisms of the sea. Some of these have the flesh of the little creatures still in them. Now these feculences of the sea, as the remains of its microscopic inhabitants may be called, are relatively as light in the water, as motes in the air; and, if the bottom of the sea were scoured by its currents, those *sea motes* would be swept away into drifts like snow or into dunes like sand, they would be scratched, their sharp corners and the edges would be broken off and rounded. Moreover, were they drifted about, then sand and other scourings of the ocean would be found mixed with them. But not so, the specimens brought

up from the deep sea show no such mixture, and the infusoria thence bear no marks of abrasion upon even their most delicate parts."

#### MAURY'S VIEWS OF A DEEP SEA CABLE.

He further states, that between Newfoundland and Ireland, the pressure varies from 200 to 300 atmospheres, that is, from 430,000 to 650,000 pounds the square foot. "Chemical forces may be measured, and consequently overcome by pressure, for the gases generated by chemical decomposition are themselves capable, so the chemists tell us, of exerting in the process of that decomposition, only so much pressure; hence, if we subject them to a greater pressure they cannot separate, and decomposition cannot take place.

In proof of this, I refer you to a recent discovery of Ehrenberg. In the specimens obtained at a great depth from the Mediterranean, that celebrated microscopist has distinctly recognized fresh water shells with meat in them. From this beautiful little fact we may infer that the very volatile gases, which enter into composition for the formation of the fleshy parts of marine animalculæ, are subjected to such a pressure upon the deep bed of the ocean, that they cannot separate. If this inference be correct, and it doubtless is, may we not proceed a step further, and conclude with reason, that with the pressure of the deep sea upon it, the gutta-percha used for insulating sub-marine wires becomes impervious to decay?"

It is his opinion, that there is no need of an iron armor around the cable, but on the contrary, the iron coat-of-mail is a great injury to the success of the enterprise. Mr. Henry J. Rogers, a telegraphic engineer, of many years' experience and of great ability, has invented a novel cable for the deep sea. The gutta-percha is covered with one or more coatings of hempen thread, whip-cord fashion, and then he protects the whole with a gum which shields the gutta-percha, securing against chafes, &c.

#### ATLANTIC TELEGRAPHS PROJECTED.

There are several routes across the ocean, proposed to be occupied by Atlantic Telegraphs. The most prominent are:

1st. The line from Norway and Scotland, respectively, to the Faroe Isles, Iceland, Greenland, and Labrador, the longest section of cable required being about six hundred miles. Greatest depth of water about 1,400 fathoms.

2d. The route of the late Atlantic Telegraph, from Ireland to Newfoundland, requiring a cable in one section, exceeding

two thousand miles. Greatest depth of water, about 2,100 fathoms.

3d. From some point in Europe to the Azore Isles, and from thence to America, for which the longest stretch of cable required, will exceed fourteen hundred miles. The greatest depth of water, about 2,600 fathoms.

4th. And, the next route, is in the extreme south, running along the European and African coast, in the sea, touching at the Madeira, Canary, and Cape Verde Isles, and thence to the Isles of Don Pedro and Fernando Noronha, to South America. The line then to follow the coast north to the Isle of Trinidad, thence to the West Indies, across St. Thomas, Porto Rico, Cuba, and thence to the United States. The longest stretch of cable required for the route, will be about one thousand miles. The greatest depth of water, about 3,500 fathoms.

With the Rogers deep sea telegraph cord, Lieut. Maury thinks a line can be successfully laid from one continent to the other. In regard to ocean telegraphy, it is due to the distinguished Superintendent of the National Observatory to say that he only discusses the Neptunian obstacles to the laying of an Atlantic cable, and he very correctly and fairly says:

*“The real question for future projectors of lines of submarine Telegraph, is not how deep, or how boisterous, or how wide the sea is, but what are the electric limits to the length of submarine lines.”*

# TELEGRAPH CROSSINGS OVER RIVERS

---

## † CHAPTER XLVI.

Telegraph Crossings in Europe—The Great Crossing over the River Elbe—Wide Spans of Wire on the Continent—River Crossings in America—Description of the Great Mast on the Ohio River—Suspension of the Wire over the Masts—A Western Frontier Telegraph Crossing.

### TELEGRAPH CROSSINGS IN EUROPE.

THE telegraph lines in Europe do not traverse very large rivers, compared with those of America. The Elbe, the Neimen, and the Dwina, are the widest crossed by the wires on masts. The telegraphs on that continent have, therefore, had but little experience in crossing rivers with the lines erected in the air. As a general thing, throughout the world, the use of masts has been abandoned, and submarine crossings adopted in their stead. In order, however, that the telegraph may be prepared to meet any emergency, I will explain in sufficient detail, the manner of using masts for long stretches over swamps or rivers.

In regard to the crossings of streams, the opinion entertained in Europe is, that rivers under twelve hundred feet in breadth, are to be crossed in this manner, in all cases where it is practicable, having reference to the height of the masts of the vessels passing under the line at the highest level in the rainy season.

It being impracticable to give precise rules applicable to each case, it will best fulfil the object of these pages to give an exact description of some remarkable river crossings effected in this manner in Europe.

The following are the details of the construction of the telegraph masts at Norwich.

The river is but 62 feet broad at high water, and then nearly level with its banks.

The masts, one on each bank, each of two spars, are 150 feet apart, and 100 feet above ground. The lower mast is 1 foot in diameter, 70 feet above ground, into which it penetrates 10 feet, and is stepped in a buried frame of two beams, crossed at a right angle, each 20 feet long, 6 inches square, the ends connected by four timber pieces, strengthened at the angles by wrought iron straps and bolts. There are four timber struts, each 12 feet long, one from each end of the cross piece, bolted to the mast, 2 feet below the ground. For the attachment of the stays, there are four piles at equal distances, each 8 feet from the mast, 1 foot square, 12 feet long, shod with iron, and provided with iron caps and bolts. A stay of one inch iron rope leads from the top of the lower mast to each of these piles.

The top mast is thirty-six feet long, and thirty feet above the lower mast; the compound mast being one hundred feet above the ground.

A cross stay of iron wire rope runs from mast to mast, 7 feet below the top. Two stays, also of iron wire rope, lead from the same part of the mast to two piles 60 feet from the lower mast, and of the same dimension as the other piles. The top mast is secured by four stays of iron wire rope, attached to cross-trees in the usual mode of mast rigging.

A spindle and vane, serving also as the point of a lightning conductor of iron rope, completes the mast.

The telegraph conductors are six wires of No. 8 galvanized iron of the best kind. They are led through brown stoneware insulators, attached to the mast at its highest part, and above the stays. The wires are strained tight, and led, each set, to a telegraph post one hundred feet from the mast, and thirty-five feet high. From these posts the wires join the lines at each side.

Instead of the expensive and troublesome plan of framing for the underground work above described, in India they employ the screw piles, six feet long. These piles carry a lower mast 35 to 40 feet high. Four of the ordinary small piles, 3 feet long, are first screwed into the ground, each at 20 feet from the spot where the mast is to be erected. The mast fitted in its pile is raised into its position, and steadied, tent-pole fashion, by four rope guys lashed, as required, to a short spar in the smaller pile; four loops of iron wire on an iron plate fitting loosely on a pin in the mast, serve for the attachment of the guys, and keep the mast perpendicular, while it is screwed into its place. This

is effected by lashing a strong spar, by its middle, to the top of the pile, by a piece of chain, and a party of five men at each end man this spar, capstan manner. The screwing is easily accomplished in a stiff clay, sandy, or light gravelly soil, in five minutes. Four iron rope or rod iron jointed guys should then be permanently attached to screw piles of the three-foot pattern, planted obliquely in the ground. Each pile has a short wrought iron link for the attachment of the guy, and each guy has a tightening screw to regulate its tension.

## THE GREAT CROSSING OVER THE RIVER ELBE.

The most remarkable crossing on masts, in Europe, is that over the river Elbe near Hamburg. I have frequently examined that crossing, and as it is regarded by the European telegraphers as a great achievement in the art, I will give the details of it as furnished by Mr Gerk, the engineer of the line. The principal arm of the Elbe is about 1,200 feet wide, and is navigated by sailing vessels of moderate tonnage.

For rivers averaging 1,500 feet in breadth Mr. Gerk advises the use of masts strongly and substantially built, and from 30 to 40 feet higher than the highest masts of the vessels which have to pass below. This is necessary to allow for a deflection of one fiftieth in the wire, which, when of the very best description, can be strained no tighter, without great risk of fracture by storms, or by the weight of icicles in northern climates.

Five masts, such as I will proceed to describe, were erected in 1848 for the crossing of both arms of the Elbe.

Each mast penetrates 10 feet in the ground, and is there wedged down between strong cross beams, and the whole covered with heavy stones or concrete. About 16 feet from the end of each beam a pile is driven deeply and obliquely into the earth for the attachment of the stays, which are iron rods, one inch diameter below, three fourths of an inch in the middle, and half an inch at top. These stays lead from the piles to the top of the lower mast, where they are attached to a wrought iron collar with four eye-bolts and rings. At 9 feet from the ground each stay is provided with a straining screw by which it is tightened to the required degree.

The masts described and figured by Mr. Gerk are 180 feet high, in several pieces bound together by wrought iron rings, 2 feet in diameter at the ground, tapering to 4 inches at the top. The first set of cross-trees is at 70 feet from the ground. Four beams, each of 36 feet long, are laid cross-tree fashion at the

surface of the ground, the mast in the centre; from each end of these beams a prop is bolted to the mast at 25 feet above the ground, and stays lead from the mast at 70 feet high.

The first cross-trees for the support of the sbrouds, are four oak pieces, each 18 feet long. The second cross-trees are 8 feet long, and are attached to the mast 150 feet from the ground. Above this point the spar rises 30 feet, and carries a wrought iron cap and pin, with a porcelain or stone ware insulator of the Prussian pattern.

Mr. Gerk employs a compound wire of 3 strands of No. 19 best charcoal iron, twisted together. According to his own experiments, wire of this gauge withstands strains, storms, and casual pressure, better than any other kind.

#### MODE OF ELEVATING THE WIRE.

Mr. Gerk erects the wire in the following manner:

The wire is held ready wound on a reel, like that which ropemakers use, mounted on an axle, so as to let the wire run freely off.

The man who ascends the mast winds the end round his left arm in a knot, taking care that in drawing it after him it all runs free, especially of the backstays. When he reaches the top, he draws the end through the lignum vitæ sheave which is placed there, and either takes it with him below, or else fastens it at once by means of brass double screws to the other end of the conducting wire, which ascends from the last bottom peg, or out of the ground. In the latter case the point of connection will be in the first or second cross-tree. As soon as this is done, two men, holding the reel by means of the staff on which it is centred, get into the boat which is lying ready, and a third, or the man on the mast, takes care that the wire runs freely off during the passage over to the other side. If the river is broad, and there is a chance of ships passing by, the wire, of which there must be at least 400 feet over length, is allowed to run free in the water, while the person who remained behind at the first mast holds fast, until all is so far in order by the other mast that the fixing-on can take place. But if the river is narrow, and there is no danger of ships passing by, the wire should be held as long as possible above the water, because a possible entanglement in the bed of the river will thus be avoided. As soon as the other bank is reached, about twice the length of the mast is let run off the roller, or, if there is more on, the necessary quantity must be drawn out of the river. To avoid risk of the wire breaking, two men go back

in the boat, and, while one rows, the other lets the wire glide through his hands, in order to lift it from the ground.

If all is so far arranged, the mast-climber commences in the same manner as before to ascend with the end of the wire, in doing which he, as well as those below, ought to take care that the wire runs free, and especially that it does not hook behind the eyes of the backstays. As soon as the end is brought through the sheave, the man descends with it to the next cross-tree, binds a weight on, and lets it glide down to the man who is standing on the bottom cross-tree, who takes hold of the wire and removes the weight. A strong iron pin must be fixed in a sloping direction to the under cross-tree, in such a manner that the conducting wire may touch no other substance, and particularly no piece of metal. The iron pin is covered with an insulating cap, round which the man below lays the wire, while the one above climbs up as high as he can, and while he lays his breast against the top of the mast, stretches out his arms as far as he can, and draws to him the wire, unhindered by friction of any kind, out of the water or through the air; while the man below draws to him the wire thus gained, lays it round the insulator, and holds it tight, to prevent its sliding back again. If the wire is now so tight in its stretch across the stream that the man above cannot pull it further in with his hands, he fixes a vice to it as far out as possible, with flat teeth, and pulls in the wire as far as it will go without breaking. The proper measure is naturally the height of the ships which have to pass under with the highest high water, where a tide exists. If the wire has now its proper stretch, the man below wraps the same several times round the insulator, nips the end which hangs over pretty long off, and makes the connection to the general line.

#### WIDE SPANS OF WIRE ON THE CONTINENT

The longest span, even greater than the Elbe, in Europe, is that over the river Niemen, at Kovno in Russia. From pole to pole it is estimated at 1,700 feet, though the river is not more than half the width. A very tall tree on a very high hill is used on the west side, and a very high pole on the east side. The river Niemen is navigated by very small sailing and steam vessels. The crossing over the Dwina at Dunaburg, Russia, is another of the principal spans, though not so wide as the Elbe. The next, is that over the Vistula in Prussia. Neither the Dwina nor the Vistula is navigated by vessels with very high masts. The crossings over these rivers are, for the large wire, full long; nevertheless equal, and even greater



distances are spanned from the tops of houses in Paris, and over the Alpine regions of Switzerland. From mountain to mountain the iron thread is suspended, and on witnessing the electric cord elevated high from the green vale below, stretching from the snow-clad summits, it often occurred to me that the means used by man for the spread of the telegraph over the earth—traversing the seas and mountain barriers—was as sublime as the lightning, which Providence had made subservient for the diffusion of light and knowledge.

#### RIVER CROSSINGS IN AMERICA.

From what I have stated, the reader will see that there are no very extensive crossings in Europe compared with those of America. I will now describe a few of those on the western continent. It will be inconvenient to refer to them in the order as to the time they were respectively constructed. I will, therefore, refer to them as to facts, with the general remark, that those to which I refer were all built between the years 1846 and 1850.

The crossing of the rivers by the telegraph has been from the commencement of the enterprise a source of much annoyance and a vast expense. I think it would be safe to say, that the American telegraph companies have lost and expended more than half a million of dollars in connection with river crossings. On the extension of the experimental line between Washington and Baltimore to Philadelphia in 1845, the Susquehanna river occasioned some difficulty and considerable expense. The line was constructed some distance from the direct route in order to cross the river at a practicable point. The next formidable difficulty was that of the Hudson river at New York City. For a long time the dispatches were carried over the river by messengers in boats; but finally, the line was submerged by Mr Ezra Cornell in leaden pipes, the wire being covered with cotton, and insulated with Indiarubber. This was November 20, 1845. There were two cables thus formed, and they worked very well for several months, until they were carried away by the ice in 1846. They crossed the Hudson at Fort Lee, some 12 miles above New York City. When these cables were broken, high masts were erected and wire upon them was stretched across the river. Men were in attendance all the time to repair the wire when broken by vessels. It was the custom to let the wires down into the water for vessels to pass and then draw them up again. This was practicable in tide water, but not so with the inland rivers. The Hudson river at the place of crossing was 2,700 feet wide.

These masts were constructed under the directions of Mr. Henry J. Rogers, the energetic superintendent of the telegraph. In 1847 another effort was made to cross the Hudson with a cable, and to that end a copper wire, covered with gutta percha by Mr. S. T. Armstrong, was purchased and submerged by Messrs. T. M. Clark and J. W. Nortons for the Magnetic Telegraph Company. The cable was placed across the river at the foot of Cortlandt st. It worked a day, and was then torn away by an anchor.

On the lines constructed by Mr. Henry O'Rielly, throughout the great West, many rivers had to be crossed, over which the wire was stretched. The widths of these streams were from 1,000 to 3,000 feet. The first crossing was that at Wheeling, over the Ohio river, 1,300 feet; the next was that over the Ohio at Louisville. The latter was one of great expense. From the Indiana shore to an island it was 2,100 feet, and from the island to the Kentucky shore it was 1,300 feet. High masts had to be erected to support the wire, so that the steamers with their chimneys 90 feet above deck would not touch it. At first, a large cord, made of three No. 18 wires twisted together, was used, but its great weight prevented it from being drawn to the required elevation. Small steel piano-wire was then employed singly, and with that the full height desired could be attained, but in cold weather it contracted by the frost and frequently broke. After this experiment No. 16 iron wire was adopted and proved the most serviceable in every particular, and on all subsequent crossings this sized wire was adopted.

About the same time the crossing was made over the Wabash river at Vincennes, and then followed the spanning of the Mississippi river at St. Louis. From the Illinois shore to Bloody island it was 2,700 feet, but this arm of the river was not navigable. From Bloody island to St. Louis shore it was 2,200 feet. The mast on the Illinois shore was 160 feet high. On Bloody island it was 185 feet high and on the St. Louis shore a shot tower of equal height was used.

Crossings have also been made over the Ohio river at Maysville and at Parkersburg, the Niagara near Buffalo, the St. Lawrence near Montreal, the smaller bays of the Gulf near New-Orleans, the Mississippi at Hannibal, and many others; some of which I will now proceed to explain more in detail.

In 1849 and 1850, Messrs. Shaffner and McAfees, constructors of a telegraph south of St. Louis, to connect with New-Orleans, traversed with their line the Mississippi, Ohio, Tennessee, and Cumberland rivers, all within a distance of one hundred miles. The Mississippi river was crossed near Cape Girardeau, in the State of Missouri. The width of the span was 2,980 feet.

The mast on the Illinois shore was 210 feet high, and that on the Missouri shore was 205 and on an elevation of 110 feet, making the whole height from the water 315 feet. The Ohio crossing was at Paducah, for which three masts were employed, one being placed on a sandy island. The mast on the Kentucky shore was 307 feet high and on a bank 32 feet above the water, making an elevation for the wire 339 feet. The mast on the island was 205 feet, and the one on the Illinois shore was 215 feet. The width of the river between the Illinois shore and the island was 2,400 feet and between the island and the Kentucky shore it was 3,720 feet. The Tennessee river was crossed near Paducah. On one side a tree, 90 feet high, situated on a bank, 120 feet high, was used and on the other side a mast 160 feet high. The width of the river was 2,300 feet. The Cumberland river was crossed in the same manner as the Tennessee. The width of the river was 1,850 feet.

DESCRIPTION OF THE GREAT MAST ON THE OHIO RIVER.

Fig. 1.

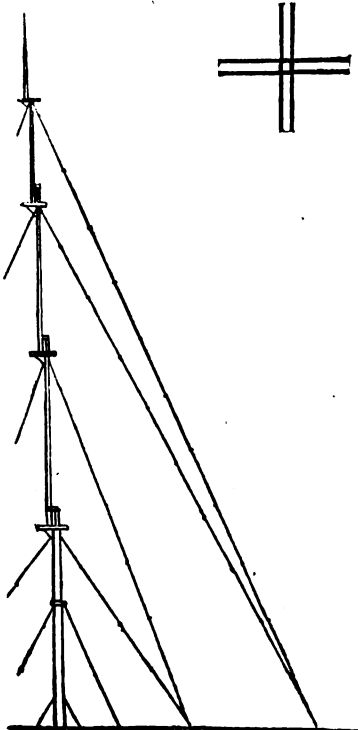

Having referred to the crossings respectively, I will now describe the construction of the mast at Paducah, upon the principles of which all the others were erected.

Fig. 1 represents an outline representation of the mast, 307 feet high. The cross timbers, fastened at the foot, are seen to the right and above in the figure. These cross timbers were fastened to 20 large cedar logs, placed perpendicularly 12 feet in the earth and 2 feet above the earth. The cross timbers were 12 inches square, 25 feet long, and were fastened to the upright posts with large iron straps. In the little square centre, 15 inches in diameter, the foot of the mast was fitted; braces of strong timber, 8 inches square, were then placed between the cross timbers and the mast, well fastened with

irons. It will be seen from this arrangement, that the foot of the mast proper did not enter the earth, but that its compound footing comprised 20 large cedar logs, united by the cross timbers, and they were united to the mast by the braces.

The first or main spar, letters *a b*, was 110 feet, the second, *c*, 70 feet, the third, *d*, 57 feet, the fourth, *e*; 43 feet, and the fifth, *f*; 27 feet. The first and second pieces were spliced, as follows. The main spar was composed of two logs, one of which was 75 feet long, 20 inches diameter at base, and at top 17 inches diameter, and the other log 17 inches at base, and 15½ inches at top. The splice section was seven feet, both spars being cut diagonally, so as to fit together and make a uniform size with the remainder of the log. The ends of the logs were not chamfered at their ends, but were made so as to rest on a shoulder. Three large iron bands were then placed around the section united. Besides these bands, the whole place of splicing was surrounded with No. 10 iron wire closely wound. The bands of iron and of the wire were sufficient for the purposes; but as the main piece was very long, and had to sustain a heavy weight, it was apprehended that it might bend. To prevent this, iron braces, commonly known in America as hog chains, were fastened to the mast, bracing 30 feet of the centre; and then, as a further security, iron guys, 1½ inches diameter, were fastened at *b* to the spar, and to the ends of the cross timbers below. The top of the main spar was also sustained by 4 iron guys, an inch in diameter. The second piece was spliced by the winding of the wire around it, as was done with the main mast, but there were no iron bands used. From the top of each spar ran 4 separate and independent iron guys, which were fastened to substantial piles buried 15 feet in the earth. The top guys were quarter-inch rods. To each and all of the guys straining screws were attached, by which they could be tightened at will.

A rope and pulley were fastened to the top of the mast, so that a man could ascend at pleasure. Some ill-disposed persons one night pulled the rope out of the pulley. I employed an expert climber, who ascended to the top, aided only by the telegraph spurs, described in the chapter on line repairing. He remained till the rope was replaced, and then descended by it.

#### SUSPENSION OF THE WIRE OVER THE MASTS.

The masts being constructed, the next to be done is the suspension of the wire over the stream. To explain this process, suppose the masts *A* and *B* are on the respective sides of the river; the wire is to be placed in the top of each through the

open insulator. Beyond **A** it should be "made fast" to the line wire. Beyond **B** the wire should be held by two or more men. The ends between **A** and **B** are loose at the ground. A small reel, containing the wire, should be suspended in a frame at the stern, of a small boat—for example, a skiff or yawl. The end of the wire upon the ground at **A** is then spliced carefully to the end of the wire on the reel. The boat is then rowed across the river to the mast **B**, where the loose wire, hanging from the top of **B**, is spliced to the reel wire. Immediately after they are united, the men beyond **B** pull the wire through the open insulator at the top of the mast **B**, until it is above the river a sufficient height. In crossing the river, care must be taken not to let the wire get into the water, particularly if there is a current; as, in such cases, it is often carried down stream, and is liable to catch in roots or rocks at the bottom; besides, it may be broken by the current, especially while being elevated. The wire used for the great crossings was No. 16 iron, unannealed. It was my practice to coat it with linseed oil.

#### A WESTERN FRONTIER TELEGRAPH CROSSING.

Before concluding this chapter, I must refer to the crossing at Kansas, Missouri, constructed in 1851, then on the verge of

Fig. 2.

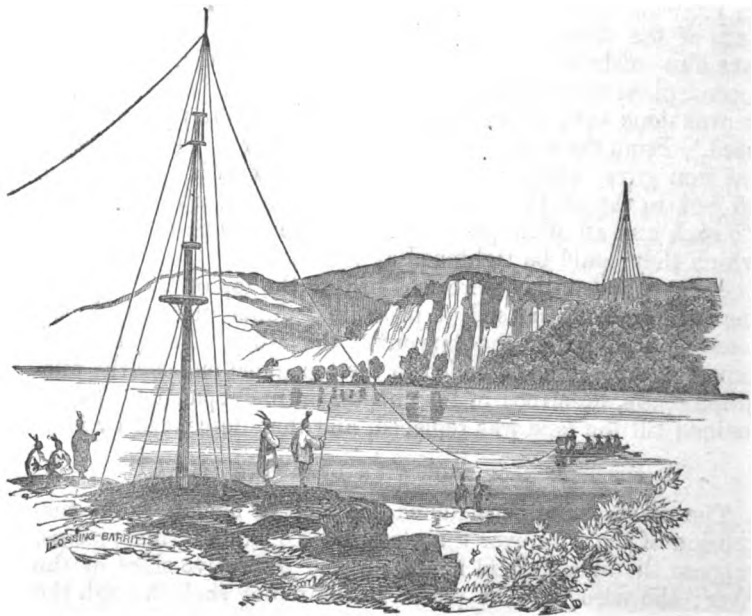

civilization. The Missouri river was about 2,100 feet wide, and one of the most turbulent streams in America. On the south bank of the river, the line was built to the frontier; and to avoid traversing the Indian territory, the wire was stretched across the river, and then built to St. Joseph, some seventy miles further westward.

Since that time, brief as the period is, a wonderful change has taken place in that part of the country. In places where I saw the Indians as the sole inhabitants, and the whole broad-spread prairies beautifully adorned with the varied flowers and green grass, now the white man has full possession, and villages have sprung up as by magic, and the ploughshare upheaves the soil so lately traversed with the red man armed with his deadly weapons, the tomahawk and the bow. On that very soil, but a few years since, the blood of the father, mother, and child, dripped from the scalping-knife, while fiendish beings danced with joy around the trophies cut from the heads of the murdered. To-day civilization reigns supreme over that same land, and the tomahawk, the scalping-knife, and the iron-pointed arrow, have been bound together with the olive branch, and now move by the breath of the Creator at the top of the sacred spire.

# CONSTRUCTION OF THE AMERICAN LINES.

## CHAPTER XLVII.

Organization for Digging the Holes—Erection of the Poles—Suspension of the Wire—Insulating the Poles.

### ORGANIZATION FOR DIGGING THE HOLES.

In organizing men for the construction of a telegraph line, much consideration must be given to the proper distribution of labor, to effect the most certain and rapid consummation of the ends in view. In the classification, a proper force must be placed at the digging of the holes, the getting and putting up of the poles, the suspension of the wire, and the necessary auxiliaries in the premises. I propose to notice each corps respectively.

The detachment of men engaged in digging telegraph holes is generally called a "squad," "gang," or "party." In my practice, I have usually termed them a "squad." The necessary implements are the shovel, fig. 1, the digger, a wrought-iron rod, about six feet long, with steel cutter at end, and the auger, with blades about twelve inches diameter, fig. 2. The use of these tools I will shortly describe. A digging squad should not exceed nine men, one of whom will act as "boss," or director. The duty of the boss is to step off the places for the holes, locating the spot of each by a stone, removing a little of the earth, or by driving a stick into the earth to serve as a mark to the diggers. The boss must be capable, and understand the whole process of construction. He establishes the range or line of the poles, so as to distribute the strain of the wire on as many of them as possible. Much expense has been thrown upon the subsequent working of lines by injudicious location of the poles; for example, suppose poles *A B C* are erected, the first on a hill, the second in a valley, and the third

on a hill. The wire will pull off the cap of the insulator used on the southwestern lines, and will pull off the insulator employed on the eastern line, as most insulators are constructed with a view to the weight of the wire hanging, instead of its strength applied to an upward force. Fig. 1

Again, angles are to be avoided as much as possible, establishing curves in their stead. From these few remarks, it will be seen that the duties of the boss are responsible, otherwise than in a proper management of his men. The squad of eight men are divided into four pairs, each pair having a digger, shovel, and an auger. In ordinary earth, two men can dig forty holes per day. To have more than two men to a hole is a waste of time, and no acceleration. I have thoroughly experimented upon this subject, and there can be no doubt of the correctness of these conclusions. Only one man can work at a time at the same hole. Now, it may be supposed that it would be better to have one man only to a hole, but such is not the case. Man is companionable, and, when alone, will not labor as fast as when associated. In a month, a squad divided into pairs will dig at least twenty per cent. more than when arranged in divisions of three, and much more than when placed one to each hole. When in pairs, each brings into action increased vigor after a little rest. The labor in digging a telegraph hole is severe on the back, and no man can toil the whole day without either an occasional rest or slowness in his work. When in pairs, the necessary rest is given, and each renews work strengthened for quick action. But this rest is not half the time, nor need it be more than ten per cent. of the time, as will be seen by the process of work.



Fig. 2.

After the hole has been located, the men commence by cutting the earth with the digger to the extent of the size of the hole at the top, usually about fifteen inches diameter. The earth being loosened about a foot deep, the other man with the shovel removes it from the hole. The digger is again applied, and the shovel again removes the earth, and so on, until the



hole is about three feet deep. One of the men then takes the auger represented in fig. 2, the blade or flange of which is constructed as seen by the side and top views, and bores the hole to the proper depth, which usually is about five feet. When the earth is very compact, four and a half feet will answer. In gravel, three and a half or four feet is found to be sufficient.

At the time one of the men commences with the auger to finish the hole, the other man proceeds to the next hole in course, with shovel and digger, and commences a new hole. He here works alone, alternately with the shovel and digger, until his companion arrives from the former hole, which has been finished by the auger; he joins in digging the hole number two, as had been done at number one. In this way, the holes are dug and left ready for the pole.

During this operation, the boss is busy locating the holes, and occasionally assisting in digging a hole; for example, when one of a pair is left to finish a hole with the auger, the other is alone at the next hole in the use of the digger and the shovel. Here the boss has an opportunity to aid with either of these tools, and in thus assisting, he becomes acquainted with the efficiency of his men; and, after a few days' service, he can readily determine how many holes his squad ought to dig per day.

In rocky earth, the auger cannot be used, and the entire hole has to be dug with the digger. In such cases, the average holes per day often do not exceed from twelve to twenty per pair of men. But in ordinary earth, a squad of nine men, with twenty-two holes per mile, can finish from six to ten miles per day.

I have never found it economical to have more than nine men in a squad, nor more than one boss for the same men. I have experimented on this fully, extending as high as forty men in the same squad, with a boss and two or more assistants. Whenever I exceeded nine men, I have found a loss, as a sure consequence. A gang of less than nine men will prove economical, but the speed will not be sufficient for the pole squad, soon to follow.

After the holes are dug, the poles should be erected as soon as possible, and at least within a few days, for the reason, that a rain may fall and fill the holes with water; and also to avoid damage to man and beast.

In regard to the first, I deem it proper to add, that after a hole has been filled with water, the pole cannot immediately be set solid. It is true the water may be taken out, as I have had done in thousands of cases, but the earth is left saturated with water, and, in fact, is a mere casing of mud. But, in the

winter season, the water might freeze, and in that case the hole is filled with ice, which is as difficult to remove as to dig a new hole. In 1847, I had dug some forty miles of holes, and a rain fell, filling many of them with water; cold weather followed, and the water was solidly frozen in each hole. In that case, I found it less expensive to have new holes dug, and the old ones were abandoned. But the loss of the first holes was not all that was sustained; there was a more serious consequence. After warm weather had softened the ice, a traveller's horse stepped into one of the holes and broke his leg. The case was brought before a legal tribunal; the traveller demanding damages. The telegraph company pleaded that it was not responsible, as the digging of the holes was necessary in the construction of the line authorized by the act of the legislature; and, besides, the holes were within the limits belonging to the road company. The tribunal held that the company was not liable, as the digging of the holes and the erection of the poles had been given under contract to other parties. Action was then brought by the traveller against the road company, and the tribunal decided that the law required the company to keep in good order a travelling way of a given number of feet wide. The telegraph hole was not in that way, but was some feet from it, and as the traveller had departed from the proper and common highway, the road company was not at fault. From these facts, it will be seen that the law fully protects the telegraph and the road companies; but there may be abuses of this privilege, and abuses of all kinds should be most studiously avoided. Notwithstanding the law cannot give the traveller any damage for the loss of his horse, I have always found it best to soften the losses, by paying something, thereby voluntarily sharing in the misfortune. This amelioration begets friends, and tranquillizes even the most vicious and revengeful heart. The world must be taken and considered as it is, and not as it ought to be. Justice would not require the telegraph to pay for the loss of the horse; but man's depravity often impels him to deeds of wrong. In the dark hour of night, revenge might be satisfied by cutting the wire, and forcing upon the company a loss greater than the value of the horse. Providence, in the end, however, brings about a retribution, as an atonement for the offended law; this atonement, some telegraphers might say, reaches not the thing ponderable.

In America, it is too often the case, that when a man feels that the law has not sustained his imagined rights, commensurate with an excited conviction, he seeks revenge through a more clandestine course, by the execution of some personal in-

fiction. In Europe, where society is taught to reverence the law, and yield in all cases to the decrees of fate, however unjust at the time, in order to attain the greatest good for the greatest number, the lines are not so much jeoparded, nor liable to malicious interruptions. A universal respect for the telegraph throughout the world, is a "consummation devoutly to be wished."

#### ERECTION OF TELEGRAPH POLES.

The implements necessary for the erection of a telegraph pole are, the pike-pole, fig. 3, made of an ordinary pole, about ten feet long, with a sharp-pointed iron fastened in one end;

Fig 3.

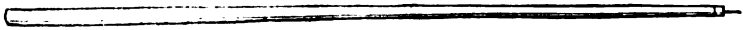

around this end of the pole is placed an iron band, to prevent splitting; the rest-board, fig. 4, being a plank about six or eight feet long, ten inches wide, one inch thick, and concaved

Fig. 4, Fig. 5.

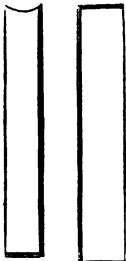

at one end, to allow the pole to lay in it; the foot-board, fig. 5, about five feet long, ten inches wide, and two inches thick, on one side a little hollowed; the cant-hook, fig. 6, made of timber, five feet long and about three inches square at the largest end, with handle end round; and about ten inches from the larger end a flat iron hook is fastened with a bolt. This iron hook can be moved, as will be seen, by the holes in it; the bolt is held firm by a screw nut, at one end, and a flat head at the other end. The pole-

lifter, fig. 7, made as a double cant-hook, excepting that the hooks are placed near the centre of the lever. This wooden rod or lever is about six feet long. The rammer is made of a

Fig. 6.

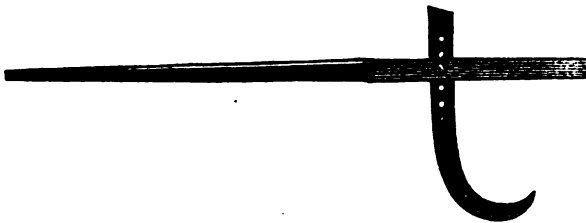

round piece of wood about six feet long, about two and a half inches in diameter at the little end, and about four inches in diameter at the larger end. Around the larger end is placed a

heavy iron band. Besides these tools, an ordinary farmer's shovel and pick are required.

The pole-squad should consist of ten men, one of whom acts as boss, six as pike-pole-men, one as foot-board-man, and two as pole-setters.

Fig. 7.

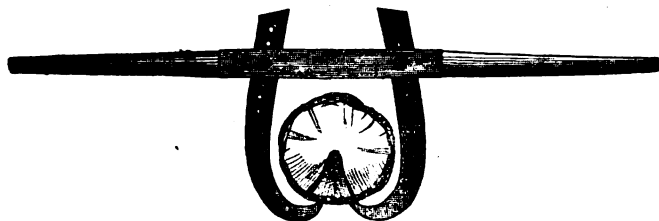

Having described the different tools and the number of men required for the erection of telegraph poles, I will now explain the proceeding in that formality.

On arriving at the hole, the first step to be taken is, to place the pole in the proper position for its elevation. The butt end must lie over the edge of the hole, and the pole must be placed so as to be easy to erect where the ground is uneven. Four men take the pole-lifter, fig. 7, and, grasping the butt end of the pole with the iron hooks, they lift the end of the pole to the proper position at the hole. Two of the men then proceed to adjust the other end of the pole with the lifter; the other two having prepared themselves with their pike-poles, fig. 3, to be ready for their use. When the pole is properly placed, the men with their hands elevate the little end about six or eight feet high. The rest-board, fig. 4, is then placed under it; the foot-board-man places his board, fig. 5, in the hole, about three feet deep, opposite the foot of the pole, as seen in fig. 8. The men then change their positions, placing their shoulders under the pole nearer the hole, when, from a stooping position, they come to a perpendicular; the rest-board is then brought nearer the hole. By this time the pole is at an angle of  $45^{\circ}$ . The pike-poles are then taken and placed under the pole, as seen in fig. 8, combining angular forces to elevate the pole to the perpendicular. When the pole is thus placed, the cant-hook, fig. 6, is applied to the pole, about ten inches above the surface of the ground, and one man can turn the pole in its upright position, so that the previously adjusted insulator at its top will be on a line as required for the wire. The instant the pole is brought to a perpendicular, three of the men with their pike-poles hold it upright for the application of the cant-hook, and

for the pole-setters to fill the hole with the earth or stones sufficient to keep it in the proper position. The other men pass on to the next hole, and proceed to arrange the pole and elevate it preparatory to the application of the pike-poles. One of the

Fig. 8.

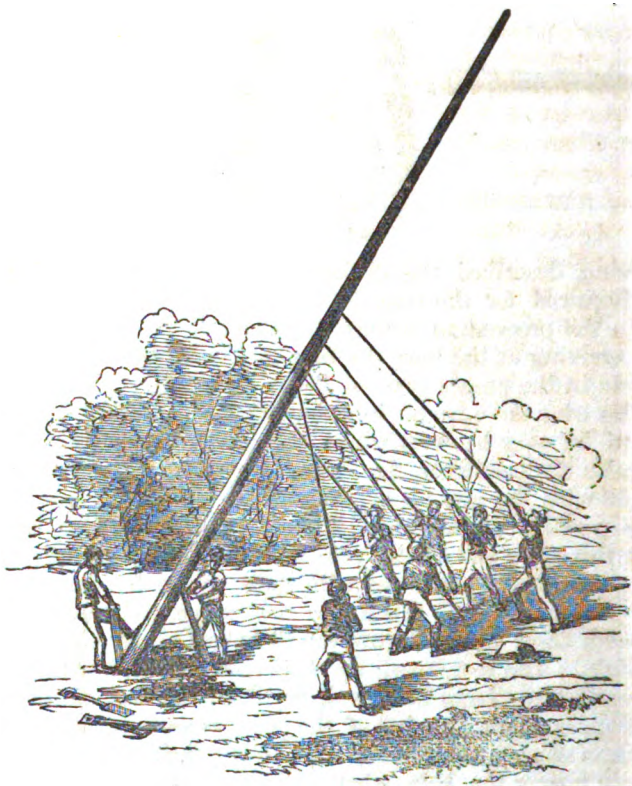

two pole-setters fills in the earth, and the other rams it to a solid state. The earth should be elevated a little around the pole at the surface of the ground, to allow for the earth to sink to a level, and to cause the water to run off, and not settle in a puddle around the foot of the pole. By the time the hole is filled, the next pole in course is ready, and so on.

By these facts, it will be seen that there will be no loss of time. Every man has to be on the active move, in order to maintain his position. The boss usually takes the foot-board, or the rest-board, which gives him an opportunity to see his men, and to give the commands from time to time. With ex-

pert men, properly organized, working ten hours per day, a corps of men thus described can erect a pole in four or five minutes. When the earth is frozen, an additional pole-setter is required. There is no position in the raising of the pole more responsible than the foot-board man; he must be careful not to allow the pole to slip either to the right or to the left from the board: because, if it does, the end is forced into the side of the hole, and the pole becomes difficult to raise, the pike-pole men lose their angular force, and the pole falls. By pressing his foot upon the pole, as in fig. 8, he can greatly facilitate its erection.

Unless the squad observe proper care an accident may happen in the raising of the pole, by its fall as above mentioned; though I never knew of but one case which was fatal. In 1847, Messrs. Tanner & Shaffner were in haste to erect some two hundred and eighty miles of line, through Kentucky and Tennessee, and a large number of men had to be employed. There were several squads for each department of the business. One of the pole squads was composed of men inexperienced in the business, and the third pole attempted to be raised, when between  $45^{\circ}$  and  $90^{\circ}$ —the pike-pole-men not applying their force properly—fell and killed one of the men. This melancholy accident caused the men to disperse and abandon the business.

When the earth cannot be rammed compact around the pole, and it is not possible to get stones or gravel to aid in setting it solid, it is usual to use braces to prop the pole. One, two, three, or more braces are used, of indefinite lengths or sizes, as seen in fig. 9. Rough sapplings, some four or more inches in diameter, are generally cut, and with one end set in the earth, and another in a notch cut in the pole, or nailed to it, or fastened with a wooden pin, the brace forming the hypotenuse of a right-angled triangle, are all that have been deemed necessary on the provincial highways in America. Sometimes sawed scantlings, four inches in diameter, are employed as braces, four to each pole, and the lower end nailed or fastened to log sills arranged around the pole, about four feet distant from the foot of the pole.

As a general practice, the bracing of posts is avoided, by changing the location of the pole, as experience has taught that it is more economical to make the line a little more circuitous than to have braced poles.

Fig. 9.

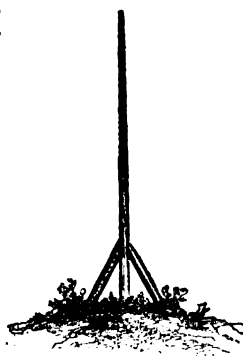

With a view to economize in labor on a line commenced by Mr. Tanner and myself, in 1847, I caused to be tried the erection of poles with a small pair of shears. This latter proved to be quite a success; but with the shears, nearly the same number of men were required, and not half the speed, as in the erection with the pike-poles.

Fig. 10.

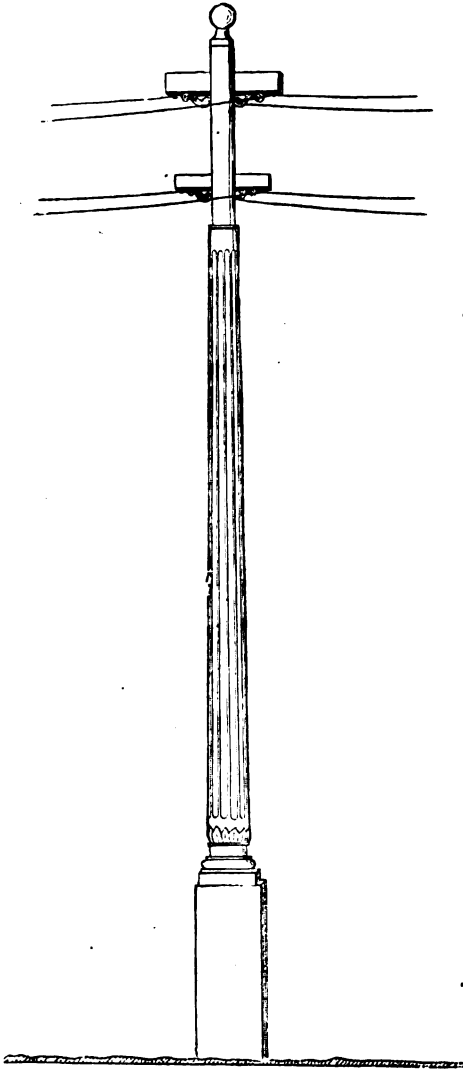

The poles along the ordinary highways are very plain, but in some of the cities much effort has been made to ornament them, especially at the stations, so that they might serve as signs to distinguish the places. In former years, when there was much competition between companies, the spirit of rivalry extended to the poles erected in the cities. Fig. 10 represents the Louisville station pole. The base and fluted column were made of iron; the round shaft above and the cross-arms are of wood, and neatly painted. At St. Louis, one of the companies was still more extravagant, and had erected a massive ionic column, some twenty feet high, and upon it was placed a full-sized statue of Franklin, with the line wires passing through one of his

hands! Another office had a large golden eagle, with outstretched wings, ready to soar off to some poetic region, the most distant from economy.

## SUSPENSION OF THE TELEGRAPH WIRE.

The telegraph wire is prepared at the manufactories in any required lengths. For some lines, it is prepared in half mile and mile hanks. The greater number of lines have had it wound on prepared reels. These reels have a drum about eight inches in diameter, with  $\times$  ends, made of oak scantlings, four inches in diameter, as represented in fig. 11. The reels are about three feet long, and upon them is wound from three to eight miles, the average about five miles. Each joint is well soldered, and a whole strand of the quantity on the reel is continuous. Fig. 12 represents one of these reels, mounted on a wagon. The reels are distributed along the line at proper distances.

Fig. 11.

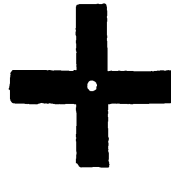

Often they have laid upon the ground along the open highways, and in the forests, for many days, without any covering. To prevent the wire from oxidation, it was my practice to have the wire well covered with linseed oil, at the manufactory, and again before distributing the reels on the route, cover the outer layers of the wire with the same kind of oil. When this precaution was taken, the wire was always found free from rust; and, besides, it preserved it from decay when stretched. This was the case with wire not galvanized. In later years, many of the lines have been putting up galvanized wire. The "wire-squad" requires a wagon, drawn by two horses. On the wagon is mounted a frame work for the suspension of the reel, as seen in fig. 12. An iron rod, one and a half inches in diameter, runs through the centre of the reel, which serves as an axle. Through the hole in the cross, fig. 11, is run the axle. This axle rests and turns in metallic boxes fitted in the upright beams of the frame-work in the wagon, as seen in fig. 12. The arrangement is the same as the old-fashioned windlass. The whole mechanism for the suspension of the reel is rude, plain, and cheap, costing

Fig. 12.

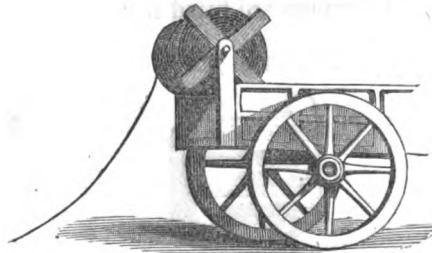



not more than some ten dollars. Fig. 12 represents a section of the wagon.

Another wagon is required for carrying insulators and divers tools necessary in the business. Two ladders, two axes, four hatchets, vices, pincers, soldering apparatus, nails, and a few spare tools are necessary. These articles embrace all that have been required on the provincial routes, especially through forest countries.

The wire corps is composed of at least thirteen men, viz.: one boss, two principal ladder-men, two assistant ladder-men, two trimmers, two teamsters, and four wire-pullers. The boss has the direction of the squad; the principal ladder-men arrange the wire and the insulators on the poles; the assistant ladder-men help in carrying the ladder and holding it firm, when the principal is mounted upon it; the trimmers cut off the branches of the trees on the line of the wire, and cut down all the undergrowth beneath the wire; the teamsters have the charge of their wagons, and, besides, aid in other work, as directed by the boss; and the wire-pullers transfer the wire from the reel, as it unwinds, to the poles, and, after being placed in the insulators, it is drawn by them taut, so that occasionally the principal wire-men may key the wire at any given pole.

Now this process contemplates the use of insulators, such as fig. 13, which are fitted in the pole as in fig. 14. This class of

Fig. 13.



Fig. 14.



insulators has been principally used on the lines traversing forest regions, so that when a tree falls upon the wire as in fig. 15, it can slide through and not break. If tied to the insulator the wire would break under the weight, at the post.

When the wire is stretched upon the poles from hanks there must be additional assistance for the handling of the small coils, and when the wire is tied to every insulator there would be economy in the employment of more ladder-men. On lines where the wire is fastened at each pole, the routes are more free from forest limbs and undergrowth. Along the railways

there is not much trimming required, so that there need be no especial men engaged for that particular service.

Fig. 15.

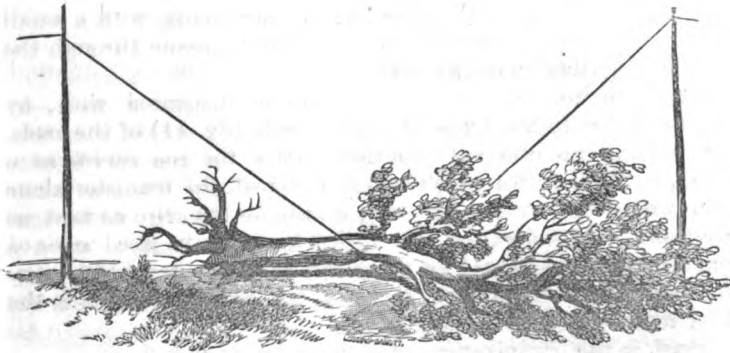

I have stated that there will be required four wire-pullers on open insulator lines, but practically, nearly the whole force assist. The wire is first placed in the insulator and it hangs loosely between the poles. After a half mile is thus arranged, nearly the whole force assist in drawing it taut. The wire runs through the insulator in the case of fig. 13, and over the arm, as represented in fig. 16. When the wire is drawn nearly

Fig. 16.

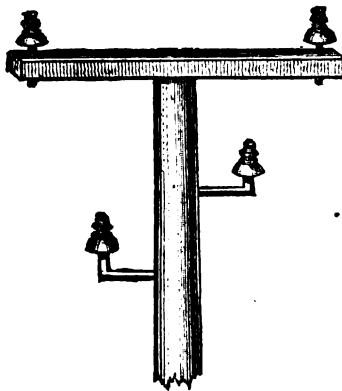

straight, it is "made fast" to a stump, a tree, or something else. The wire-men again proceed in arranging another section upon the poles, assisted by one of the ladders. The other ladder is at the same time engaged in tying the wire to the insulator in the one case, or in keying it in the other place to the last insulator next to the place where the wire is "made fast" to the

stump or otherwise. This key is a small iron in the shape of a button, with a groove through the flange from the side to the centre. The wire passes into this groove and a small piece of iron is driven into it, which binds the wire. Another mode is, simply tying upon the wire two or more nails, with a small wire, which will prevent the line wire from passing through the insulator farther than the nails.

On some routes the wire-men can be dispensed with, by boring holes in the arms of the  $\times$  ends (fig. 11) of the reels. By placing an iron rod into these holes, the rod serves as a lever, so that, with a catch wheel attached, the teamster alone can rewind the wire on the reel, arranging the wire as taut as required. On railways a reel of this kind can be fixed upon a hand-car, and employed for the purposes above described. Ordinarily, however, to avoid accident, the common wagon is the best to be used on any kind of road.

Such is the organization of a wire squad, and the mode of putting up the wire, on most of the lines that have been constructed in America. Such an organization can put up from six to ten miles of wire per day, a speed little faster than the speed of the digging of the holes and the erection of the poles. It has been usual to allow the poles to be put up some miles in advance, so that the whole line will be finished at about the same time. The speed of putting up of the wire can be reduced by dispensing with a part of the force.

#### FIXING THE INSULATORS ON THE POLES.

In consequence of there being no uniform insulator employed on the telegraph lines, a description of the adjustment of the pole for insulation can not be other than but general. I will therefore refer briefly to the manner of arranging the two different classes of insulators, viz., 1st, the open groove insulator, and 2d, the tie insulator.

The open groove insulators are put upon lines where it is desired that the wire shall not be made fast or tied at each pole. In the use of this class the pole must be adjusted for the glass before erection. In the case of fig. 13, a square groove is morticed through the top of the pole. This is done by boring an auger hole, the size of the glass to be used; with a saw a block is cut out from the end of the pole to the auger hole, so that the glass can rest in the groove, with its upper side even with the top of the pole, as seen in fig. 14. When the pole is thus prepared it is ready for erection. The adjustment of the pole for the glass is usually done after they are distributed at the holes.

# THE TIMBER AND PREPARATION OF TELEGRAPH POLES.

---

## CHAPTER XLVIII.

The Size, Preparation, and Durability of Telegraph Poles, including the Red Cedar, White-Cedar, Walnut, Poplar, Pine, White-Oak, Black-Oak, Post-Oak, Chestnut, Honey Locust, Cotton Wood, Sycamore, and other Timbers.

### POLES ON THE AMERICAN TELEGRAPH LINES.

I PROPOSE now to discuss the materials used for telegraph poles, and the different modes of their preparation for that service. All countries do not employ the same timbers and modes of arrangement, but this state of facts is not a matter of choice; it is owing to the existence or non-existence of the different kinds of wood in the respective countries. In America there is a much greater variety of wood, than is to be found on the continent of Europe. In the Northern States of America, there is not that variety that there is to be found in the Southwestern. In the former, telegraph poles are mostly of the white-oak, and the chestnut; and in the latter, they are of the white-oak, post-oak, red-cedar, black-walnut, honey-locust, ash, sassafras, and elm. In England, the larch is the most common. In Russia, the pine; in France, the pine, the alder, poplar, and other white woods; in Germany, the spruce and pine, and in India, the bamboo.

These timbers differ as to duration, when placed in the earth. The pine of Europe, however, does not decay as rapidly as the pine of America, and, therefore, the rejection of that wood in America, from service, in the construction of telegraph lines, must not arbitrarily cause a depreciation of the European pine, in the mind of the reader. The alder of France is not the same as the common alder of America—in the former country it is a tree, but in the latter it is a bush, seldom more than two to three inches in diameter, at its base.

The red-cedar and the black-locust decay less than any of the kinds of wood mentioned. The chestnut, the sassafras, and the post-oak, are next, as to durability.

Until within the past five years, in America, but little pains have been taken in the preparation of poles before setting them in the earth. Heretofore, the lines have been erected with such rapidity, that the timber could not be prepared for permanency. Often, they have been placed in the earth the same day, and the same hour that they were cut. In later years, the custom of stripping the bark off has been adopted, especially, by the House telegraph companies.

I have often observed the decay of different kinds of wood used for telegraph poles. Those cut in the winter, and set in the ground immediately, in the spring sprout, and considerable foliage grows upon them. This was the case in the Southern climate of America. The second year, however, there was no foliage, and the wood was not only dead, but in rapid process of decay. The sap had fermented, and, on chewing the wood, I found it quite sour. Poles which have been stripped of the bark die immediately; the sap evaporates, and the poles dry or become seasoned, and, when planted, they prove more lasting. Some years ago, I had holes bored in the pole at the surface of the earth and filled with salt, confining it in the hole with a plug or stopper. After three years, I was unable to see any benefit, except for a few inches at the place of the salt. Around other poles, freshly planted, I poured some brine, saturating the pole and the earth.

Stock running at large, so common in America, would eat the earth for the salt, and the experiment gave me some annoyance. I was compelled to place around the pole large stones, to prevent the earth and the bottom of the pole from being eaten away. This process, pickled and preserved the poles, and they have been standing for nine years. I also made an experiment with charcoal. I had placed around the pole in the earth, about three inches of pulverized charcoal. The pole decayed at the surface of the earth as soon as others not so prepared; the charcoal did not preserve the timber in any perceptible degree. A few post-oak poles, well seasoned, planted in 1849, are still standing, having but one half decayed at the surface of the earth; but in the earth, and above, they are sold. These poles were 10 inches in diameter at the base, and 5 inches at the top, and thirty feet long.

In connection with this subject, the climate in which the timber is grown must be considered. In the northern climate, timber grows slow and compact. The wood is not so porous,

nor does it have so great quantity of sap. The bark is generally thin, and the sappy or white wood, is but a thin belt around the interior heart or dark wood. Woodmen do not consider all the dark wood beyond the sappy part the heart. For example, take an oak-tree, two feet in diameter, a size very ordinary in America, and first is the bark, then the sappy or white wood belting the tree, about three inches in diameter, then follows the dark, or red chip, until the heart is reached, which is generally in the centre of the tree. This heart is solid and tough. The dark or red wood is penetrated by sap. In some seasons of the year, I have noticed, when felling the oak, the walnut, and many other kinds of timber, the sap to run in little streams from the white and the red wood alike. The post-oak is much like white-oak, but it is a tree of slow growth, and is to be found mostly on dry and gravel uplands. It is more durable than the white-oak, in the earth. Cedar and locust have but very little sap, and the fibres are closely interwoven, so that there can be but little absorption. It is a saying, that "cedar and locust never decay." These woods can be regarded as the most durable that we have in America. Poles, ten inches in diameter at the base, will remain good, thirty or forty years in the earth. If the bark is left on the pole, it will sooner or later decay, and the solid wood is left, and weathers the storms and seasons for a lifetime. All kinds of wood will be more durable when stripped of the bark. Chestnut and sassafras will hold out from ten to fifteen years. White-oak, post-oak, honey-locust, ash, and black-walnut, about six to ten years. White-pine and poplar, about three years; black-oak, red-oak, and sycamore, about two years. All kinds of fruit-tree wood, one to two years. The pitch or yellow pine pole is quite durable in the earth. The turpentine or rosin does not ferment, but it forms a plastic throughout the timber, and prevents the absorption of moisture, and thus it is preserved from decay. Much of the rosin, when the pole is exposed to the sun, oozes out, and the exterior of the pole becomes coated with it.

The durability of the different kinds of timber mentioned, when used for telegraph poles, depends much upon the soil in which they are set. When planted in light alluvial soil, the decay is much more rapid than when placed in wet clay. In the former case, worms easily get through the earth to the pole, and, besides, the pole is more exposed, and absorbs the moisture of the earth with more rapidity; but, in the latter case, the clay serves as a plaster, filling up the cavities of the wood, so that water cannot penetrate it. In such earth,

I have frequently found the hickory wood petrified, making excellent razor hones, one of which I have had in service for twenty-five years. I have already stated that it was important to strip the pole of its bark, because if it is not taken off, worms shelter under the bark, and make rapid work eating away the wood, to reach the solubles buried in its recesses. They penetrate through the fibre in every direction, until the nourishment is exhausted, when the worm dies from starvation. The thousands of holes made by the worms aid to diffuse throughout the wood the moisture of the seasons, and in this way, in a few months, the pole decays, and yields to an ordinary strain of the wire, or to the force of the wind.

The white-cedar has been used in some sections of the United States, but it gives but little service. It is composed mostly of the sappy or white wood, differing from the red-cedar, which has not more white wood than the thickness of a knife-blade.

Some companies have had poles sawed from the large white-oak of the forest—large at one end, and tapering to the other. The poles were sawed square, and they gave promise of being very serviceable. Their cost was about five dollars each, which was at once a bar to their general use. Their durability has not been equal to the round sapling of the same locality, and of the same wood.

In 1848, the Magnetic Company constructed a new line of poles from Washington to Baltimore, in replacement of the poles erected as an experimental line in 1844. These new poles were of chestnut, stripped of their bark, and well charred at the earth end. The soil on this line is sandy, or gravel intermixed with clay. Many of these poles remain to the present time. Their diameter at the base is about eight inches.

As I have stated herein before, the telegraph lines in America have been constructed with such rapidity, that it was impossible to procure poles properly prepared, for permanency. I have known lines erected at an ordinary rate of one hundred miles per month, by one corps of workmen. While one set of workmen were digging the holes, another was cutting and hauling the poles, another was fitting the insulators, another would raise the poles, and the last would stretch the wire on them. In this way I have superintended the construction of ten miles in a day. This rapidity was occasioned by rivalry. The main object of the rival companies was to reach certain cities first, regardless of every consequence.

The House telegraph lines are more modern, and are better built. All the poles were selected with much care, of good

timber, well stripped of the bark, seasoned in the sun, at least ten inches in diameter at butt, and five inches at top, well set in the earth, and on a right line to avoid the strain of the wire on angles.

In the early days of telegraphing, especially on rival routes, when the lines traversed forests, but little care was taken in the selection of poles. The great quantity growing in proximity was an excuse for slight in the first building, the impression being "that the poles were readily replaced, in case of decay, and time should not be wasted on first construction." The people "ahead," always anxious for the completion of the telegraph, often had an influence in causing the constructors of the line to erect poles of inferior wood and size, and to use any means, however frail, to consummate an electric connection.

On many lines the forest-trees serve for posts, to which brackets or cleets are fastened, and in or on them insulators are fitted. These brackets or cleets are nailed to the body or limb of a tree. On one section of a line, embracing about sixty miles, I noticed that on more than one half of the route trees were used, and on a section of six miles there was not a post. The trees were large, from one to five feet in diameter at base, very high, and with outspread branches, shading the earth. The sun's rays could not penetrate through their foliage, to warm and vivify the small growth beneath. Weeds grown there were few, delicate, and frail. Small wood growth was seldom to be seen. There was nothing to disturb the wires thus attached to the stately oak. The telegraph wires, sometimes, in America, traverse gloomy mantled forest regions, where the foot of man never had trod before. In some of these mountain ranges, the cliffs or precipices, to ascend or descend, were difficult. The wagons were taken to pieces, and elevated or let down, as the case required, with ropes, or by strands of wire.

A few years in the Western States of America, makes a wonderful change in the appearance of the country, as to its settlement. Through many of the dense forests and widespread prairies, where ten years ago the wire was run for miles, without passing a habitation, now the rail-trains are hourly sweeping through villages, and the wire is no longer the solitary evidence of civilization. Farms have sprung up as with magic. To these railways have been transferred the telegraphs, and the meanderings from tree to tree are done away with, and the iron strand is stretched on methodically-set poles of the



best of timber. On many of these railways much care has been taken to procure durable wood. On the routes through Illinois I have recently noticed that the lines were nearly entirely built of red-cedar, brought by water and rail from some section, hundreds of miles distant. Such poles are durable, and will need no replacement in the present generation. They cost from three to five dollars, according to expense of transportation. In 1849, I had cut two thousand cedar poles in middle Tennessee. I paid for them standing, 50 cents each. When cut they were placed on rafts, and floated to the mouth of the Ohio river, where they were transferred to a steamer, and carried to St. Louis, as cargo. From there they were carried by wagon, and delivered on the route of the line. They were from thirty to thirty-five feet long, and about eight inches diameter at base, and at least five inches diameter at top. The average cost was five dollars each. These poles are at this time as solid as they were the day they were set in the earth.

The cost of telegraph poles depends upon the kind of timber, the size, and the quantity growing on the given section of the country. An average may be considered at one dollar and fifty cents, Spanish, delivered on the route. The cost of stripping the poles of bark from ten to twenty cents each, depending upon the kind of timber. A rough post-oak is more difficult to unbark and neatly dress, than the walnut, the cedar, chestnut, and other kinds of wood.

Early in 1848, I constructed a section of the great New-Orleans line in the West, and being pressed for posts, I purchased a large number of oar poles, used on the flat boats which had descended the Ohio river with coal, corn, or other things of trade. The poles were of pine and white poplar, but generally well seasoned. The poplar of America is a porous wood, and absorbs a large quantity of water, which causes its early decay. I purchased some coal-tar from a gas establishment, and had it spread upon the butt end of each pole about six feet high. It required about a half gallon of the tar, per pole. The coating, and all the expense accompanying the operation, cost about thirty cents for each pole. In 1853, those poles, thus coated with coal tar, were solid, and scarcely any decay could be seen. Poles of the same wood, and set at the same time, not coated, had to be replaced in 1852. Had the poles been green, and freshly cut, they would not have lasted more than two or three years.

The telegraph poles in America are not so well prepared as

they are in Europe, although there is no reason why they should not be, and of better timber, and more substantial. The sorts of timber are more general and abundant. There is every facility necessary for their proper preparation, and there is no country demanding permanency of structure more than the telegraphs of America.

Along the ordinary roads the length of the pole is from twenty-five to thirty feet, size at base ten to twelve inches in diameter, and at top five to six inches in diameter. They are placed from eighty to one hundred yards apart, and set with the windings of the road. On some lines an effort has been made to set the poles on a straight line as much as possible, and at curves or angles in the road, the poles are set so as to divide the strain on as many of them as possible; more ordinarily, however, a good substantial pole is selected for the angle, and set at about fifteen degrees from a perpendicular, so that the strain of the wire will bring the pole to an upright position.

In good soft ground the poles are set about four and a half to five feet; in hard gravel about four feet; in rocky places about three feet. I never knew of holes drilled in the rock for telegraph poles, except perhaps in Nashville, Tennessee, where many of the streets are natural rock beds. In loose rocky places, a hole some one or two feet is opened with a crow-bar, and when the pole is set in it, rocks are piled up around it some three or four feet high. This requires less time than blasting a hole through the rocks, and it fully serves the purposes. Where the soil is marshy, braces are framed around the pole, but of these more particular descriptions will be found in the chapter on the construction of telegraph lines in America.

Along the Western and Southern rivers, the cotton-wood sapling abounds in great quantities, but the wood very soon decays, and on that account it has never been employed for telegraph poles. I am of the opinion that if they were injected with the sulphate of copper, as hereinafter described, they might be made of very great service, and prove economical to many companies throughout the southwestern country of the United States.

## CHAPTER XLIX.

**Poles on the French Telegraph Lines—Their Preparation—Injection with Sulphate of Copper—Size, Cost, and Durability of the Different Kinds of Wood**

### POLES ON THE FRENCH TELEGRAPH LINES.

In France, on the early established lines of telegraph, the posts were ordinarily about twenty feet high, except at railway crossings, and through villages, where they were some thirty feet. These lines were upon the railways. In 1854-'57, I noticed on the railway from Paris to Versailles, very small poles, not more than fifteen feet high, and some two and a half inches in diameter at top. These poles had some two or three wires on them. Comparing this line with the others of France, it was clearly to be seen that it was not even the ordinary line, as to substantiality. As a general thing, however, the poles on all the telegraph lines in France, are small, straight, and slender, nicely barked, planed, and often neatly painted, having on one set of poles sometimes as many as twelve wires.

When the lines were constructed on the public highways, or common roads, the minimum height of the pole was established at twenty-five feet, and through villages at from thirty to forty feet. The wood employed for telegraph poles is mostly pine saplings; on some lines alder and poplar, and other kinds of white wood, are used. The alder is different from the American wood or bush known by that name. There are no fixed dimensions for the poles. The prices paid for poles are as follows, viz. :

| Height.  | Diameter 40 inches<br>from base. | Diameter at the top. | Price.     |
|----------|----------------------------------|----------------------|------------|
| 40 feet. | 10 inches.                       | 5 inches.            | 15 francs. |
| 36 "     | 9½ "                             | 5 "                  | 12 "       |
| 32 "     | 8 "                              | 4 "                  | 4½ "       |
| 27 "     | 7 "                              | 4 "                  | 3½ "       |
| 25 "     | 6 "                              | 3½ "                 | 3 "        |
| 20 "     | 5 "                              | 3½ "                 | 2 "        |

In sections of the country where wood for fuel is cheap, the earth end of the pole is charred; in other sections it is coated

with tar as far up the pole as forty inches above the surface of the earth. In latter years, the poles are generally impregnated with a solution of sulphate of copper, for the particulars of which I am indebted to Mr. Blavier.

The process of injecting the posts is simple, and easy of execution on any route of the telegraph. To repeat, in part, what I have stated in the preceding chapter, wood, exposed to air and moisture, very soon decays, first the white or sap wood, and then follows, but in a less rapid degree, the dark wood, or the heart. The alteration is the result of the soluble substances contained in the wood, which, under the action of moisture and heat, ferment, decompose, and form acids. Rottenness is, also, produced by worms and insects which feed upon the soluble substances, and gnaw the woody fibres. Wood containing the greater quantity of sap, the earlier decays; while, on the contrary, wood with little sap, such as red-cedar, black-locust, &c., remains solid for a very long time. It has been found that by causing the wood to be penetrated, in every direction, by a solution of a metallic salt, the sap is forced out, and the imperishable substances, precipitated into the cavities of the wood, penetrating its fibres, so as to form in the interior an unalterable compound, renders the wood more permanent. The principal cause of destruction being thus removed, the wood remains unchanged for an indefinite time, even under the most unfavorable circumstances.

Mr. Blavier gives great credit to the success of Dr. Bouche-rie, who has given the subject much study and particular attention; and from the facts gathered on my repeated visits to France, I am led to suppose the great desideratum has been attained. He has made many experiments, and he has announced his preference for the material known as the sulphate of copper. The best solution he found to consist of one pound of copper to one hundred pounds of water. Among the materials which he tried were the pyrolignite of iron, sulphate of zinc, and acetate of lead, but none of these equaled the sulphate of copper.

The mere soaking of the wood in the solution does not answer the purpose. The sulphate must penetrate into all the pores, and take the place of the sap and other liquids in the wood. In order to properly inject a cubic metre, or about three and a half cubic feet of wood, about five and a half kilogrammes, or about twelve pounds of sulphate of copper is required.

All parts of the wood are not susceptible of undergoing an injection to the same and equal extent. A tree is formed of two parts, the heart and the sap-wood. The sap-wood is trav-

ersed by the solution with facility, but not so with the black-wood, or the heart of the tree. The post-oak absorbs the solution beyond the sap-wood, with difficulty, if at all. Wherever the sap runs, the solution will penetrate. Cedar and locust are durable in the earth, because they are mostly free from it, the fibres being too compact to admit of the passage of the water, except around the surface, and, on this account, there can be no fermentation, either by the sap, or water absorbed from the earth, for neither can penetrate its compact mass. Woods best adapted to injection are the pine, spruce, alder, poplar, cotton-wood, and, in general, all the white timbers, which are mostly formed of sap-wood.

This injection may be effected in different ways. It takes place more or less rapidly according to the nature of the wood, its age, and the time of the year. The most favorable season is when the sap is ascending. The periods of the year when the least favorable, are July, August, and the winter, when it freezes.

Mr. Blavier considers the preparation as one of the most beautiful and useful discoveries of the century; and much credit is due to the administration of the telegraphs in France, for adopting it, and causing its general application. It has well subserved the purposes desired, although the extent of its usefulness has not yet been established, as will be seen from the results hereinafter explained.

In France small sheds or shanties are constructed near the forest where the poles and water are easily obtained. The process of injection, however, is not required to be under a shelter, and may be done with none other shelter than the broad-spread canopy of the heavens.

The tree being cut and stripped of its branches, is carried to the sheds, where it is prepared for the injecting process. The wood should not be cut more than three or four days before the time of injection; the sooner after being cut the better. At first the solution was made to penetrate by its own weight, aided by the ascensional force of the sap. In the shanty was placed the reservoir of the liquid, at a certain height, so as to give to the solution a considerable pressure. This first method is still in use, the arrangements being very simple, and answering the wants of the administration, particularly in places where but a small number of posts are to be prepared.

For the purpose of injecting posts, the dimensions of which exceed twenty-five feet long, a scaffold is erected about thirteen feet high, from three to seven feet wide, and of a length vary-

Fig. 1.

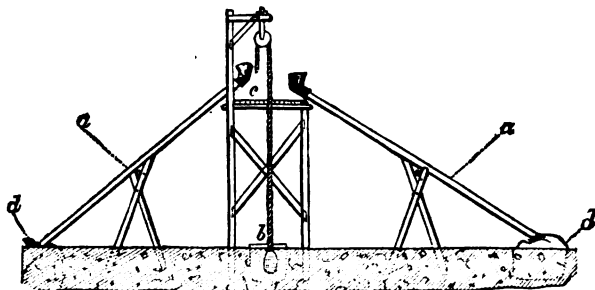

ing according to the number of posts to be prepared at one time, as seen in fig. 1.

Against the two sides of this scaffold, the poles *a a* are leaned at such an inclination, that their upper part may be within easy reach on scaffold floor *c*. The small or upper end of the pole rests in a little ditch of the earth, *d d*, sloped to fit the angle of the pole. This ditch may be a trough made of plank or iron. This trough empties the liquid coming through the posts into casks.

On the side, and above the scaffold, is a framework with a pulley and a bucket, by means of which is drawn up the solution from a reservoir, *b*, situated on the earth.

The posts are drawn up with their bark on. The summit of the tree, or the top end of the pole, is placed at the ground, and the large end on the scaffold, so as to give the movement of the liquid the natural course with the sap. A thin slice is sawed off the butt or foot end of the pole, to give a free egress for the liquid. The butt end is given the form of a frustum of a cone, to which is fitted a lead receiver made of two frustums of cones united. The axis of the upper cone is always vertical. These caps or receivers made of lead, about four fifths of an inch thick, must fit perfectly tight to the pole, so that the liquid can not leak out and waste; and in order to accomplish this, the butt end of the post is surrounded with soft clay before the liquid is put in the receivers. This capping of the post is generally done before they are raised upon the scaffold. As soon as the posts are placed as indicated in the figure, the injection commences.

The lead caps are filled with a solution of the sulphate of copper taken from the reservoir.

This liquid must contain one pound of the sulphate to one hundred pounds of water. In order to make the solution easily,

it is best to first prepare in a special cask a concentration of the liquid, having about two and a quarter pounds of the sulphate for about twelve gallons of water. It is sufficient to take from the cask ten parts for one hundred parts of water, which is put into the reservoir situated at the foot of the scaffold.

In proportion as the liquid in the lead caps passes off, it must be replaced. The workmen charged with this labor must visit them several times during the night, in order that they may not be left empty. The caps, however, may be made large enough to hold a sufficient quantity of the solution to run all night. When once the injection commences, it ought not to be stopped.

After several hours the sap is seen to flow in the little gutter or trough at the little or top end of the pole. When this is seen, the injection is not yet completed, and it is only when the sulphate of copper is seen flowing out of the pole, that the injection has been perfected. For a pole twenty feet long, the injection requires thirty-six to forty-eight hours. For a pole thirty-two feet long, at least five to six days. It frequently happens, at the commencement, that the operation of absorption does not take place, on account of the collection of the resin of the pine at the butt end of the pole. This is easily remedied by sawing off a slice at the end, and the replacement of the lead cap. This difficulty may be avoided by allowing the end of the pole to soak several hours in a vat or pool of the sulphate solution, when the poles are brought to the shanty or shed. A slice should always be sawed off the end of the pole, before capped for injection. The liquid that runs from the gutter or trough, will answer to soak the end of the pole, as preparatory before injection.

When the post is properly injected, it is known by striking at the small end with a hatchet, and the greenish hue of the sulphate is seen. The fact can be ascertained also by employing the cyanuret of potassium. By rubbing this substance on an unbarked part of the pole, the wood will become red.

This mode is carried on to a very great extent in the provinces of France, but a new mode in the application of the sulphate has been adopted, where many poles are to be injected. This new mode requires less labor, and the injection is more rapid, the solution of copper being pressed by a considerable force, so that it will penetrate rapidly into all parts of the wood, and completely *drives out* the sap.

In figure 2, it will be seen that the reservoir *r* is placed upon a scaffold of about twenty-five feet high. It is fed by the casks *g g g*, in which the solution of the sulphate of copper is

Fig. 2.

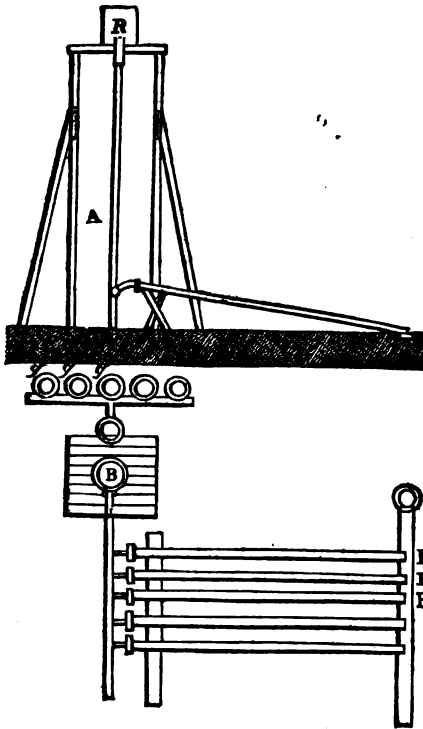

prepared. The sulphate is raised into the reservoir by means of a pump or bucket. A lead or copper pipe passes from the reservoir to another similar pipe placed horizontally. The length of the latter pipe is proportional to the number of posts to be injected, say one hundred feet for one hundred posts. From this latter pipe branch out gutta-percha pipes terminated by a copper or wooden faucet, by which the liquid is introduced into the posts.

The posts to be injected, P P P, are all placed parallel, and in a direction perpendicular to the main pipe, the tip-ends rest upon the earth, on the border of the little gutter or trough into which the liquid is to pass away. The butt or bottom ends of the posts rest upon a beam raised a little over three feet above the ground, in order to enable the workmen to put on the caps or receivers conveniently. In order to cap the posts, there is placed upon the upper face, or butt end, after the slice is sawed off, to allow an early absorption, a piece of plank made from



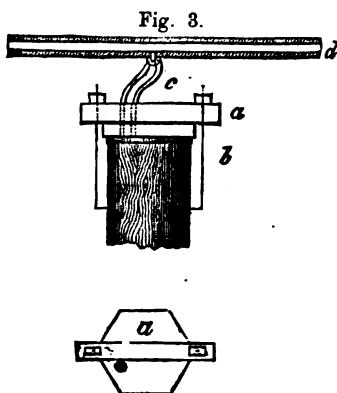

the heart of oak, fig. 3, *a*, which is strongly pressed against a band of India-rubber at the base of the pole. This is evidently the most important part of the operation, for it is indispensably necessary that the liquid, acting under a strong pressure, shall not escape at the butt end of the pole, when in process of injection. At first this piece of oak plank was screwed on by a strong copper screw, to the post. At present a

piece of solid wood is placed across the oak board, or cap, and this cross piece is fastened to the pole by two iron rods or spikes, *b*, which are driven into the posts. By lightening these rods, a heavy pressure is thrown on to the oak-board, and the India-rubber.

All escape of the liquid is prevented by a circular groove made in the head, or butt of the pole, on which the India-rubber band is put. The faucet, attached to the distribution tube by a gutta-percha pipe, *c*, is introduced into the oak plank through a hole. The liquid thus submitted at the base of the post, to a pressure of about twenty-five feet high, penetrates with great force into the wood, and at the very moment the communication with the reservoir, *d*, is established, the sap is seen to run out at the little end of the pole. The injection of a telegraph pole about twenty-seven feet long, requires, on an average, about three days.

In order that the injection should be complete, each post ought to absorb a quantity of the sulphate of copper proportioned to its solution, calculated at the rate of about twelve pints for forty cubic inches.

The metals used in the preparation of the pole for injection, should be copper or lead, or iron galvanized with zinc or copper. The object of adopting the oak-wood head-piece, is because it is impenetrable to the solution.

When the injection is completed, the faucets are closed, the caps are taken off, and the post is placed in a frame, in order to unbark it, to cut off the knots, and to shape it with a plane, as a finish.

It is well not to set the pole immediately after injection, because it will absorb a large quantity of water with the copper, and if they are placed vertically before drying, a part of the water, containing in suspension the sulphate of copper, would

descend by its own weight, and carry with it a portion of the sulphate of copper.

The expense of injection, comprehending the cost of the sulphate, the sheds, labor, &c., is as follows :

|                             |           |
|-----------------------------|-----------|
| For Posts 32 feet long..... | 50 cents. |
| “ “ 25 “ .....              | 20 “      |
| “ “ 20 “ .....              | 20 “      |

The durability of posts injected with sulphate of copper, has not yet been determined. Mr. Blavier says that posts erected in 1849, are almost all in good condition, while on the other hand, poles not injected have decayed, and had to be replaced about every three years. While at Metz, in 1857, I was informed that many of the poles on that line not injected, decayed in two years. At Strasbourg I was informed that poles charred, and not injected, decayed in about three years. The same information was given me at Lille, Havre, Rouen, Nancy, and at different parts of France.

Poles from twenty to twenty-five feet long are put in the ground about five feet. Poles from twenty-seven to thirty-three feet long, six and a half feet. The holes are made ordinarily with a pick and a spade. The earth is put in the holes when the poles are set, in layers of twelve inches, and made solid with a pestle or rammer. In rocky places the holes are drilled from twenty to twenty-four inches deep, and the foot is cemented with lime.

In ordinary land the setting of posts twenty to thirty feet long, costs about twenty cents ; poles twenty-seven feet, about thirty cents, and poles thirty-two feet long, about forty cents. Where the land is difficult to dig, the cost is increased. In rocky places, requiring the post to be cemented, the price is about one dollar and a half, Spanish. The tops of the poles are pointed, in order to turn off the water. Two coats of paint are put on them generally, one before they are set, and one after. The price of painting is according to size, from twenty to forty cents each.

The following are the average prices paid for the poles delivered at the shanty for injection, and for their setting and painting, viz. :

|                    | 20 ft. long.  | 25 ft. long.  | 32 ft. long   |
|--------------------|---------------|---------------|---------------|
| On Delivery.....   | 40            | 60            | 80            |
| Injection.....     | 20            | 30            | 50            |
| Setting.....       | 20            | 30            | 40            |
| Painting.....      | 20            | 30            | 40            |
| <b>Totals.....</b> | <b>\$1 00</b> | <b>\$1 50</b> | <b>\$2 10</b> |

## CHAPTER L.

Poles on the English and other European Lines—Baltic Squared Timber—  
Saplings of Larch, Pine, Spruce, &c.—Poles on the Hindostan Lines—  
Bamboo, Iron-Wood, Teak, Saul, and other Timbers—Their Preparation  
and Durability.

### POLES ON THE ENGLISH TELEGRAPH LINES.

In Great Britain of the timber for telegraph poles, the most acceptable is the larch. In former years they were of Memel squared timber, chamfered down the sides. The following table shows the dimensions of the posts made from the Baltic timber :

| LENGTH.  | AT BASE.       |                     | AT TOP.        |                     |
|----------|----------------|---------------------|----------------|---------------------|
|          | Drawing Posts. | Intermediate Posts. | Drawing Posts. | Intermediate Posts. |
| 18 feet. | 9 in. x 8 in.  | 6 in. x 6 in.       | 7 in. x 6½ in. | 5½ in. x 4½ in.     |
| 22 "     | 10 " x 8 "     | 7 " x 6 "           | 7 " x 6½ "     | 5½ " x 4½ "         |
| 28 "     | 11 " x 10 "    | 8 " x 7 "           | 7 " x 6½ "     | 5½ " x 4½ "         |

These poles have been superseded by the round sapling wood, which is preferable to the Baltic cut or sawed timber. The saplings are cheaper, and more readily obtained, and if straight and well selected, stronger than the sawed pole. There has not been time sufficient since the adoption of the round poles, to test their relative durability. Gate-posts have been tried of the two, however, in wet and dry places, and the larch sapling has proved to be the most serviceable. The Baltic timber decays in about six years, so that they had to be cut off at the surface of the earth, and reset at a less length. This reduction would bring the pole to about ten feet above ground. This height might be considered as too low, and liable to interruption by mischievous persons ; but in England the laws are rigid, and as the lines are placed within the railway fences, any interference would be a trespass on the railway, which, by act of parliament, is no small offence. On some lines where these poles have not been sufficiently long to admit of being reset, they have been cut off at the ground, and fixed in a cast-iron screw socket, similar to the dwarf screw pile used for breakwater fastenings.

The sapling poles of larch, now so generally used in England, on the telegraph lines, are eighteen feet long, nine inches in diameter, at the lower end, and five and a half to six inches in diameter at top, both ends measured after the bark is taken off. Crossing poles for railways and highways, and for villages, are from twenty to twenty-eight feet long, according to circumstances.

After the poles are neatly stripped of their bark, and allowed to dry a short time in the air and sun, carefully avoiding their warping, the butt ends are well charred to about a foot above the depth they are to be fixed in the earth. This charred part of the pole is then soaked in gas tar for about twelve hours, the poles are placed in a standing position in tanks filled with the gas-tar, arranged within a timber framework.

Poles thus preserved will last for many years, and although the expense is great at first, the economy in service will prove of tenfold gain. The cost of these poles varies, depending upon localities, as in some districts they are plentiful, while, on the other hand, in other districts they are very scarce, or not to be gotten at any price.

Poles of the dimensions mentioned above cost three, four, or six shillings each, barked, the knots planed off smooth, and the lower ends charred and tarred. Twenty-five are generally fixed per mile, unless there are other supports, as walls, buildings, bridges, or viaducts. In former times thirty to thirty-two were used, but a less number, of late, has been considered preferable. The poles have been increased in size, and set deeper in the earth, so as to have more strength, and few points of suspension for the wire, thereby improving the insulation.

#### POLES ON OTHER EUROPEAN LINES.

In Prussia the pine and spruce are generally used on the telegraph lines. The saplings of the wood are very abundant, and are found along most of the routes. The poles are neatly trimmed of bark and knots. The lower ends are well charred, and in many places they are painted. Much care is taken to season the wood before setting in the earth, and more recently the injection system of France has been adopted, and successfully applied.

In Russia, the poles are of pine. No country excels Russia in the universality of substantial telegraph poles. The pine saplings are felled in the forest, and neatly barked and planed. Then they are allowed to season in the air and sun. After this they are well charred at the butt end, for at least a foot above the earth's surface. Besides this preparation, they are mostly

coated with gas or coal tar, and many of them, even through the interior of Russia, are painted a lead color. They are well set in the earth from four to five feet, about twenty-five feet long, and at least five inches in diameter at the top. There are, on an average, twenty-five to the mile.

In Austria, the German States, Denmark, and Sweden, the poles are as those in Prussia. In Denmark, on the island of Zealand, a pole line has been erected to supersede the underground line from Copenhagen to Corsor, along the Royal Danish railway. I have lost the details of the expense of this line, but I will remember, on being consulted about the building of it, by the very able administrator-in-chief, Mr. Faber, the propositions received estimated the poles at from one to two dollars each.

#### POLES ON THE HINDOSTAN TELEGRAPH LINES.

In India the telegraphs have been constructed under the direction of the distinguished telegraph pioneer, Dr. O'Shaughnessy. In this country there are two kinds of lines; the first are those put up speedily, as temporary or flying lines, in order to establish correspondence between any two or more places, in cases of emergency, for the government. On these lines single iron rods, five sixteenths of an inch, galvanized, 1,120 lbs. per mile, have been run across the country, supported on bamboos, palm-trees, guran posts, and other *light* and *cheap* timbers available in the districts, painted with coal tar, and planted fifty feet apart. No insulators are used, the rod being laid in the notches cut in the posts. The other, or second kind of lines, are more substantial than the first or temporary lines. On the substantial lines, sixty lofty posts of the best timber procurable, each shod with an iron screw-pile, penetrating three feet into the ground, are erected to each mile. On these posts insulating brackets of great strength are fastened, and the iron wire or rods, No 1 Birmingham gauge, are keyed or braced so as to allow, at the lowest point, sixteen feet above the level of the ground, to permit laden elephants to pass under the lowest part of the line.

These lines are built of poles of the iron-wood from Arracan, which are known to be almost indestructible by damp, fungus, or insects. This wood is so hard that it is cut with difficulty by the axe. It is very heavy, and the transportation expensive. It is used in its sapling form, and the posts are, on an average, twenty-four feet high, and five to six inches diameter at the base. The butt end is tapered by the adze and plane, so as to fit closely into the hollow iron screw-pile, in which they are to

be inserted into the ground. When iron-wood is not procurable, teak, saul, or any other good timber, is used. In the mountains oak and pine are used. Deep-rooted trees, occurring on the line, are used freely, as in America, but in India the tops of the trees and their limbs are cut off, and the bark is wholly removed. The toddy palm-tree is used where convenient. Each post is branded with a letter or a number, in some conspicuous place. Before placing the posts in the iron screw-pile, the insulating cap and the bracket are securely attached to the post. When thus arranged, the pole is ready to be fitted into the screw-pile. The screw-piles are used for the double purpose of protecting the timber from decay and insects, and for the great strength they afford in resisting displacement, by shocks and strains of every kind. While two men can readily pull down or displace a post of equal size, planted in the earth without a pile, ten men cannot accomplish this when the screw is used, without the aid of shears and tackle. The screw-pile also greatly facilitates the erection of the posts.

The screw-pile to be employed, is three feet one and a quarter inches long, and seven and a half inches in diameter at top, hollow and conical. Its head is six-sided externally, and round internally—thickness of the iron three fifteenths of an inch. It tapers to a point below. The screw-flange commences close to the point, and making three turns, terminates ten inches above the point. The diameter of the screw-flange, at its greatest width, is twelve inches.

The post and the iron screw-pile united, constitute the telegraphic post. The pile is screwed into the ground by a wrought iron bar, with a four-sided opening at one end, in which the neck of the screw is received. This is called a "spanner." It is nine feet long, and fits closely to four sides of the hexagon head of the screw. The "spanner" is worked like a capstan bar, and gives leverage for setting the pile in the earth.

To screw down a pile, a party of nine men is required. One of the men commences by making a hole in the earth with a crowbar. This hole need not be very deep, but if the ground is hard and pebbly, it must be two to two and a half feet deep. The screw-pile is then placed quite upright, with its end in this hole, and the lever or spanner fixed on the pile to screw it down. Four men are required at each end of the lever, and one man should carefully attend to the screw, watching whether it goes down straight. Everything being ready, the men now go round steadily and slowly; there must be no hurry, and care,

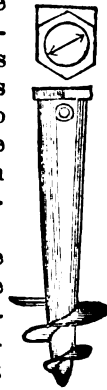

must be taken to work the lever as horizontally as possible. If the men press downward at one time more than another, the pressure will make the screw go crooked. It is also a great object not to let the pile "wabble," as it loosens the earth. If the ground is very stiff, and the screw bites imperfectly, it may be taken up, and the hole made somewhat deeper with the crowbar, or a pailful of water may be thrown into the hole, and one or more men should stand on the head of the pile, the penetration of which is much accelerated by their weight. The pile having been screwed into the ground within six inches of the top, the posts are now to be erected, the intervals being exactly three hundred and thirty feet, or sixteen to the mile. At that distance the iron rod employed can be braced up with ease by the straining machine, so that the deflection from the horizontal line, is no more than eighteen inches, being scarcely perceptible to the naked eye. At this span, three men, of four hundred and twenty pounds weight, have been supported on the rod in the centre of the span, without causing it any injury. After about one hundred posts are erected, the iron rod is lifted from the nearest bamboo, and placed on the centre of the permanent post. This is the process of removing the iron rods from the temporary posts to the permanent line. Each end of the section being removed, the iron conducting rod is fastened to a tree by a large chain or to a log of timber some eight or ten feet long, placed transversely in a trench four feet deep, and the earth well rammed in the trench, to hold fast the log. The temporary posts may now be removed, except intermediate posts between the permanent poles, which are retained until the straightening of the line is perfected, and in fact some are kept all the time on some lines, or until the transmission of the current is interrupted by them. On such as are retained, the iron rod is insulated as follows, viz.: a strip of strong and cheap silk from Assam, Bagulpore, &c., one and a half inches wide, and thirty-six inches long, is saturated with a solution of shellac in wood naphtha. This strip of silk is wound round twenty-four inches of the rod, smoothly, and spirally, overlapping one half in each turn. This is repeated until a double layer is formed. When this dries, it constitutes a flexible non-conducting coating, which does not soften by the sun's heat, and is not affected by rain. The silk and lac coating is also given to the rod where it touches the permanent pole. When the silk and lac are not procurable, Madras cloth, or any strong and porous fabric, is used, saturated with pitch. From these facts it will be seen that the India lines are the most substantial in the world.

# REPAIRING OF TELEGRAPH LINES.

## CHAPTER LI.

**Qualification and Duties of Repairers—Continuous and Uniform Metallic Conductors—The Joining of Telegraph Wire—Repairing a Break of the Line Wire—The Interruption of the Line by the Falling of Trees—The Great Sleet of 1849 and the Telegraph Lines—Destruction of the Telegraph Lines by Lightning—A Silk Cord Splice found in the Line—Novel Cases of Repairing the Line—Removal from the Line of all Foreign Conductors—To preserve the Insulation of Wire—To Secure the Permanency of the Structure of the Line.**

### QUALIFICATION AND DUTIES OF REPAIRERS.

THERE is no part of the telegraphic service more important than the repair of the line. Unless it is properly restored, when out of order, difficulties may be experienced for months, and even years thereafter. On a line of some five hundred miles, traversing wild and forest regions, a fault may escape discovery, perhaps for ever. The repairer of the line should have a reasonable knowledge of the science of electric currents; and, as the men engaged in this department are generally of but limited education, the operators in the stations ought to teach them as much as possible the science, so that their efficiency may be the greater for the general weal of the company. Unfortunately, however, the operators sometimes are too selfish to diffuse knowledge. They prefer to be wise themselves, looking to an increase of salary. Such acquisitive characters ought to be discountenanced by the principals of every telegraphic organization. In the long and varied career which I have had in telegraphing in different climes and on different continents, I have always endeavored to teach others to the fullest extent of my power. It has afforded me pleasure, and the recipient has felt a sense of gratitude. What higher consideration need we have in this world, than a consciousness of "doing unto others as we would they should do unto us?"



If the repairer is ignorant of the necessities of the telegraph, he may omit to do that which ought to be done, and he may do those things which ought not to be done, all resulting from an ignorance of the established science. I have too often felt the consequences of improper repairing. Some years ago, while acting as president of a telegraph range, I found it economical to employ men who understood the full requirements of the telegraph.

The duties of the repairer may be considered under the following heads, viz.:

1st. To maintain a continuous and uniform metallic conductor.

2d. To remove from the wire all foreign conductors, whether metallic or otherwise.

3d. To preserve a proper insulation of the wire.

4th. To secure the permanency of the poles and other structures of the line.

I will now explain these respective duties; and as to the first, *to maintain a continuous and uniform metallic conductor*. The voltaic electricity employed for telegraphic purposes, requires a uniform and continuous metallic conductor from station to station. When I say a uniform conductor, I do not mean to say that a wire of different sizes and qualities will not answer for transmitting telegraphic intelligence, but that a uniform metallic rod or wire will subserve the purposes better in the maintenance of an efficient current of electricity. Much might be written on the subject; but for practical purposes I need say but little in illustrating the established philosophy in the premises.



Suppose  $A B$  is a line of an indefinite length, the wires between  $A$  and  $a$  and  $b$  and  $B$  are the same in size; the wire between  $a$  and  $b$  of a much smaller size; the batteries are at  $A$  and  $B$ . The wire between  $a$  and  $b$  being small, I will suppose, can conduct but half or fifty per cent. of the electric current that the wires  $A a$  and  $b B$  can convey. Suppose  $x$  and  $z$  are faulty points in the wires  $A a$  and  $b B$ .

Ordinarily the small wire,  $a b$ , is called a wire of resistance, because the volume of the current is lessened to the conducting capacity of the wire, and as it cannot equal the powers of the wires  $A a$  and  $b B$ , it is called a resisting wire. The term is objectionable; but it has become a technicality in the art of telegraphing, and I use it as such.

In regard to the conducting functions of the respective sections given in the example, there seems to be a diversity of opinion. Some suppose the wire between  $A$  and  $a$  and  $b$  and  $B$  hold as fixtures their full quantity of the electric current. Place between  $a$  and  $b$  the larger wire, and the current will be uniform between  $A$  and  $B$ . On the other hand, it is believed that the batteries at  $A$  and  $B$  only generate a voltaic current in quantity or force, equal to the conducting power of the wire; thus, if a battery of fifty cups fully charges the wire to its complete capacity, whatever addition may be made to the number or size of the cups or cells of the battery, the plus will be inactive, electrically, notwithstanding there will be chemical action on the whole battery.

It is not material for me to determine, at the present time, which of these opinions is correct. The operator at the apparatus readily perceives the increase or the decrease of the electric force on the line; and when the conducting medium is disturbed, the effect is instantly observable in the adjustment of the relay magnet of the apparatus. There can be no mistake in the opinion, that lesser sized wires are, technically, resistants to the flow of the voltaic force.

In the diagram above given, the current sent from  $A$  to  $B$  or from  $B$  to  $A$  will be effective, in proportion to the conductivity of the wire between  $a$  and  $b$ . Suppose there is a bad joint at  $x$ , the current transmitted from  $A$  through  $a$   $b$  will reach  $x$  much enfeebled, or in other words, in less quantity or volume. Much of the current passes away on the route, by heat, fog, rain, and contacts of various kinds. Besides this loss of current, the intensity sufficient to overcome distance becomes lessened. When, therefore, the current arrives at  $x$ , it is so feeble, that it is difficult for it to overcome the fault, and in such cases  $B$  receives the dispatch with much difficulty. If there is a fault at  $z$ , the full voltaic force is hindered, and the volume or quantity of the flow from  $A$ , beyond  $z$ , is not commensurate with the exercise of the functions of the battery. A line thus situated is very inefficient, and the remedy for the case is only by the repair of the line, or by the establishment of relay stations at  $x$  and  $z$ , or at some other part of the line. Suppose the line is perfect from  $A$  to  $x$ , but the fault at  $x$  is a metallic contact, shorter, but inferior to the remainder of the line. In this case,  $B$  will receive, if at all, with difficulty; but  $A$  will receive from the battery of  $B$  with less hindrance. The quantity of the current in proximity to  $x$  is so great, that its intensity overleaps the oxidation, or passes through the inferior conductor at the point  $x$ , and goes on to  $A$

On the other hand, the battery at A is too far off to be thus effective. It must always be remembered, that there are two elementary organizations of the voltaic force, namely *quantity* and *intensity*. Philosophers have discussed these two classifications in the most extended sense. I will not enter into a discussion of them here, and in their use, I will be plain, though at the risk of criticism. Some scientific gentlemen dislike to see technical terms made common, but I have no other alternative left me. This book is written for the practical telegrapher, who has to work day by day in the mysterious agency of a science, the explorations in which have been but limited. Besides this reason, many of the technicalities in the electric science have different definitions, are differently applied, and are differently understood by scientific gentlemen. It is my aim to use terms and language that can be understood by the reader, and I hope my purpose will be appreciated.

In order to have *intensity* sufficient to overcome a given distance, a commensurate current of *quantity* must be generated by a voltaic battery. Some batteries generate currents of *greater quantity* and *less intensity* than others. To attain the *greatest intensity*, scientific gentlemen have been experimenting for many years, and to some extent with success.

From what I have said in the above, it will be seen that it is important to maintain a uniform metallic conductor on a line of telegraph. To the consummation of this end, it is the duty of every repairer to exert his energies, and never to omit the correction of a faulty place in the wire.

#### THE JOINING OF THE TELEGRAPH WIRES.

Telegraph wire is manufactured and delivered upon the route in lengths to suit the constructors of the line. Many of the joints are made at the manufactory, and many have to be made along the line as the wire is placed upon the poles. No joint should be made unless soldered; but the conveniences usually had heretofore for this process along the line, have been but few, and, therefore, a line of some five hundred miles has had, perhaps, some several hundred joints not soldered.

In America, we have had our full share of experience upon the subject. Having built in a few years more lines of telegraph than elsewhere in the world, we have had full scope for experiment. The early lines were not so carefully constructed, owing to the great haste required in their completion, especially on rival routes. I have had lines constructed having thousands of joints not soldered, and they worked very well. It can-

not be denied, but what those lines would have worked much better, had the joints been well soldered.

On a line built by Mr. Tanner and myself, in 1848, the wire was delivered by the manufacturer on reels, in lengths of six miles. The joints were made in the egg form, as seen in fig. 1.

Fig. 1.

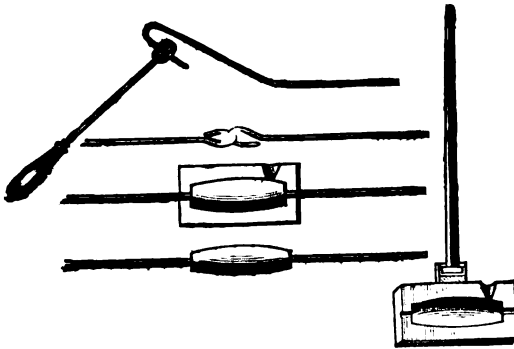

The first example in the figure is the process of bending the wire, the second is the hook joint made ready for the solder, the third is the joint soldered in the mould, the fourth is the point finished, and the fifth, to the right, is a half of the mould showing the handle. This was supposed to be the best joint that could be devised. In order to make the solder adhere to the iron, the ends of the wire were immersed in chloride of zinc. The chloride is of a pasty nature, readily attracts moisture from the air, and should be kept in bottles. It is made by dissolving pieces of zinc in dilute muriatic acid.

On the Hindostan lines, in Asia, Dr. O'Shaughnessy adopted the egg joint, and he has expressed himself pleased with it, as a success on No. 1 wire. It is not used on the European lines. In America, we found it objectionable; the wire broke at many of the joints. Proper care was not taken at the manufactory in cleaning the wire. Many of the joints were made with the ends of the wire covered with a thick coating of oxyde. But, under any circumstances, this joint is objectionable. The solder is an inferior conductor; and, besides, there will not be a complete metallic connection between the wire and the solder. The iron contact is small. The hook presents but little iron surface for a contact, and the metallic conductor is, therefore, only equal to the surface contact at the hook. If but one third of the metal or the surface of the wire is brought into contact, the conductivity of the wire is lessened in pro-

portion to the said contact. If the wire at the hook is covered with an oxyde, a long line would be difficult to work. Having fully tested the egg joint, and at a very great sacrifice, I abandoned it, and substituted the twist joint.

The object in using solder, is not so much to make a metallic connection with the solder metal, but it is to prevent the wire from oxydation, thereby securing a continuous and extended iron connection, commensurate with the full conductivity of the iron wire employed upon the line.

On the English lines, the joints are all soldered and carefully made. Fig. 2 represents a joint formerly quite common on the English lines.

Fig. 2.

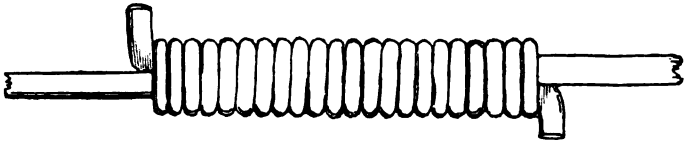

The line wires were laid together for two inches, and the ends were turned up, as seen in the figure. The binding wire was of a lesser size, and galvanized. Over these wires was placed the solder. When a strain was placed upon the line, the binding wire was closely pressed together. The solder did not always reach the line wires. This joint was better than the twist joint not galvanized.

In latter years, the joint most universal is that represented by figure 3.

Fig. 3.

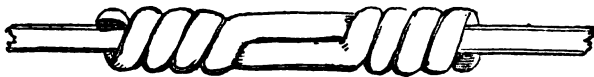

The wires are laid together, and held by a clamp in the middle, about half an inch in width. The wires on each side of the clamp are then twisted together. Before the wires are united, they are always filed until they are bright and free from rust. When thus cleaned, they are ready for splicing in whatever form desired. After the splice is made, and the ends cut off, as seen in fig. 3, the next process is putting on the solder. The wire being heated, the chloride of zinc is spread over it; the solder is then touched to the wire, it melts and spreads over the joint, and the whole surface becomes tinned. Sometimes the wire is immersed in melted solder. When thus

coated with the solder, the bright metallic contact of the wire remains perfect forever, and the voltaic current can pass without any hinderance on account of a deficiency of metallic substance, either as to extent of surface or metal.

The joint represented in fig. 4 is common upon many lines. It has much merit, and it is much easier made. The two wires are placed side by side, and then the two clamps are made fast to them, tightened by the screws seen in the figure.

Fig. 4.

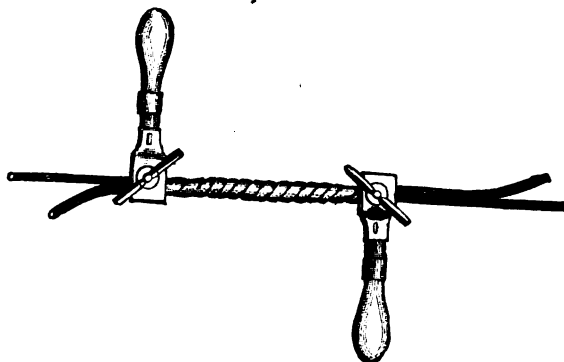

The handles are then turned in opposite directions, until the twist is complete, as seen in the figure. The ends are then cut off with a file, the solder applied, and the joint is complete. By this arrangement, one man can make a joint with considerable facility; but to make the joint as fig. 3, two men are necessary to accomplish the same speed attained by the one using the clamps, as represented in fig. 4.

I have been particular in describing the mode of making joints, because it is the most important part in the construction and the repairing of a telegraph line.

#### REPAIRING A BREAK OF THE LINE WIRE.

At the principal stations, men are under employment expressly to repair the lines. At the local or interior stations, the operators perform that service. The stations are at various distances apart, extending to fifty and sixty miles distant from each other. Suppose the stations be fifty miles apart, the operator will have twenty-five miles of line on each side of his station, or fifty miles of line, to keep in repair. When the line is found to be down on any given section, the operator immediately prepares his implements, and proceeds on horse to mend the line. He carries around his shoulders a bundle of

wire, some fifty feet in length. In his saddle-bags, he has his vices, hammer, hatchet, nails, insulators, file, clamps, climbers, pulleys, and soldering apparatus. He is mounted, as seen in fig. 5.

Fig. 5.



Being thus prepared, he proceeds at a rapid gait along the highways, through uninhabited forests, or wherever the wire runs, until he finds the place of difficulty. No one unacquainted with the business of telegraphing, can appreciate the labors of the repairer. While others are comfortably seated around the fireside, the operator has to traverse forest and wild regions in rain, snow, and hail. Through the cold, chilling blast, he wends his way along the wire thread, anxiously seeking for the break. Solitary and alone, he thus nobly performs his task. The break being discovered, he proceeds to draw the ends together, as represented in fig. 6.

The pulleys are made fast to the ends of the wire, as seen in the figure, leaving loose about two feet, to enable him to make the joint. When drawn together sufficiently close, the rope he holds is fastened to the pole or to something, until the joint is

made. This process of mending the wire is more suitable for the open or groove insulators through which the wire runs. If the tie insulator is used on the line, the wire should be untied

Fig. 6.

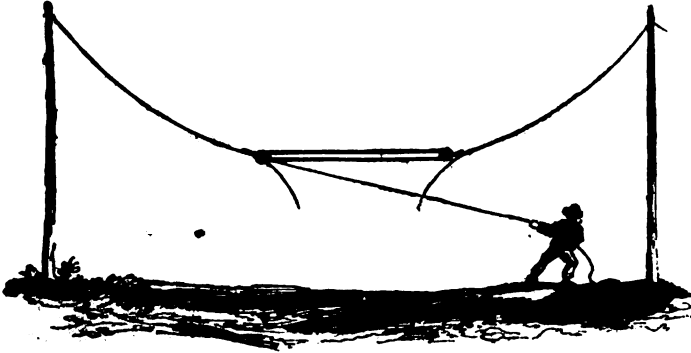

from some three or four poles, and then drawn together on the earth. After it is united, the wire can be elevated to the top of the poles without difficulty.

It often occurs that a bracket is broken from the pole, or from the tree, and the wire falls to the earth, preventing the transmission of the voltaic current. In such cases, the operator or repairer must ascend the pole, and replace the bracket. To do this, climbers with spurs are used, by the aid of which, the pole is climbed. These climbers are made of iron, in form as represented by figs. 7 and 8.

Fig. 7.



Fig. 8.



Some of the climbers have one spur, others have two, as seen at the lower end. The spur is pointed with steel, and made very sharp. The straps are made to fasten around the leg. The spurs placed on the inside, and thus fixed, the pole can be ascended easily. There are other contrivances for



climbing, but those represented above are the most approved. When thus prepared with the climbers, he places a belt of leather around his body and the pole loosely; the wire is placed over his shoulder, and he then ascends the pole, step by step, until he attains the height desired. By adjusting the weight in a proper angle on the spurs and the belt, there will be no danger of falling, and the work can be performed without difficulty. Fig. 9 represents the repairer mounted twenty feet or more up the pole or tree, arranging the bracket. The wire lies over his shoulder. Sometimes the wire is laid on the belt between the body and the pole.

Fig. 9.



Having completed the necessary repair of the line, he returns to his office, and assumes a more pleasing duty—the transmission of the accumulated business.

#### THE INTERRUPTION OF THE LINE BY THE FALLING OF TREES.

Many lines in America are constructed along the ordinary highways through the interior, and often the wires traverse the grain fields and forests, regardless of roads of any kind. Trees frequently fall over the line, and in their fall the wire is brought to the earth, as seen in fig. 10.

In case the repairer finds a tree upon the line, as is frequently the case, there are two modes of making the repair, either by cutting the tree at the wire, and allowing it to rise, or to cut the

wire and mend it again. The first is the best, but often attended with much more labor. An operator unaccustomed to the axe, will find it very laborious to cut through a tree some

Fig. 10.

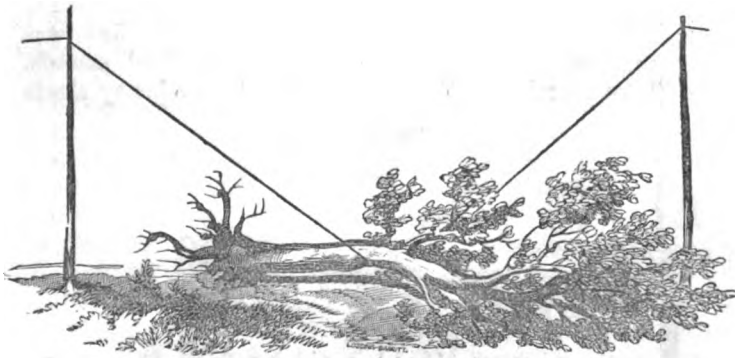

two or three feet in diameter. In case the tree is cut, care must be taken not to stand in the line of the ascent of the wire. On several occasions, I have known the axe-man to be thrown by the wire from five to ten feet high. With care there will be no danger. In case the wire has to be cut, the following should be observed: the pulleys should be "made fast" to the wire, as in fig. 6 preceding, eight or ten feet from each side of the tree, the ropes should then be drawn as taut as possible and tied. The wire can then be cut, and the ends joined and soldered. When the joint is finished, a rope should be placed over the wire, and the ends fastened to the tree with a noose. The pulleys should then be taken off. The strain of the wire will then be wholly on the rope tied to the tree, which, on being untied, the wire will ascend with great force, and vibrate like the string of a violin when touched. The slack once between the poles at the tree will be diffused over a mile of wire, but to the eye none can be seen, the whole appearing to be as taut as when first put up. From this description, the process may seem difficult, but practically such is not the case. After a line has been constructed a year or more, the wire elongates, and there is much spare slack, so much in fact, that it would be well to tighten the wire occasionally, when the line is generally repaired. This slack of the wire presents an opportunity to the repairer to take out of the line bad joints, and the making of better ones.

**THE GREAT SLEET OF 1849 AND THE TELEGRAPH LINES.**

The most serious misfortune that ever befell the telegraph in a single night was that produced by the great sleet of 1849, in the Southwest. The lines in every direction through Tennessee, Kentucky, Northern Mississippi, and Alabama, were levelled to the earth in a few hours. The wire employed on the lines was number ten, averaging in strength some ten hundred pounds. In the States mentioned the climate is mild, and heavy sleets

Fig. 11.

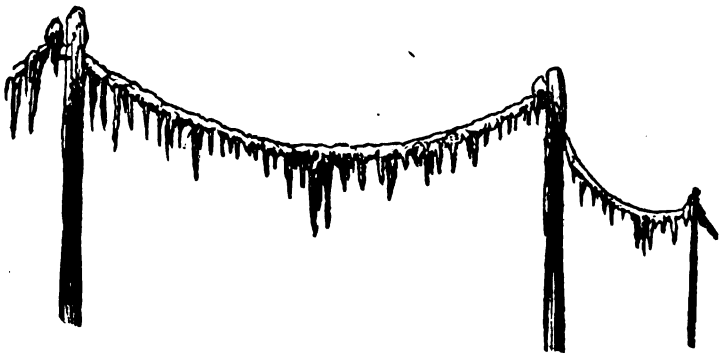

seldom occur. The ice formed upon the lines, as seen in fig. 11, and the wire was broken between hundreds of the poles. In woodland countries, where the ice failed to break the wires, the limbs of trees were broken down, and falling upon them, aided in the general disaster. It was a sad time for telegraphers. For about four weeks, all business in the transmission of dispatches was suspended, and all employés were engaged in the restoration of the lines. Several hundred men additional were employed; and although the work was equal to rebuilding the line, some twelve hundred miles of telegraph were repaired in the remarkably short time of one month.

**DESTRUCTION OF THE TELEGRAPH LINES BY LIGHTNING.**

In the Southern and Western States, the lightning is severe upon the electric telegraph. Many times the wires are struck and burnt. I saw a piece of wire that had been matted or fused together; it was twenty feet long; and how it became drawn into a mass of some two feet in diameter, resembling a tangled string, no one, save Divinity, can comprehend. On one side of the wire there were bubbles. The poles were torn to

pieces for about a mile. In most cases the wire is left uninjured, but it is common for the poles to be split and scattered about on the earth. Sometimes the poles are mostly split at or near the earth. Great care has to be taken to preserve the apparatuses in the stations; but the means of protection will be explained elsewhere.

#### A SILK CORD SPLICE FOUND IN THE LINE.

A vexatious interruption took place on one of the lines a few years ago, which for a time defied discovery. On testing the line in the morning, at an interior station, the line was found to be broken, and, as supposed, the end of the wire was suspended in the air. No circuit could be formed with the battery. As soon as possible, the operator was travelling upon the route of the line, in search of the place of difficulty. He proceeded to the end of his section, twenty-five miles, where he met the operator of the next station in course. Each reported his section in order. The wire was cut, and one section was found to be perfect and the other not. Diligent search was made by the operator of the section at fault on returning to his station, but nothing could be found. No foreign matter touched the line, and the wire was seen properly suspended between every pole. The next day was spent in vain search for the fault. The office was again examined, and all was right there. It was then supposed that some joint was imperfect. The operator, with others to assist, proceeded to examine the joints on the line. He cut the wire five miles distant from the station, and found that the difficulty was farther off. At the end of the next five miles, he cut the wire, and found that it was between him and his office. He returned, and cut the wire every mile, until he found the quarter of a mile on which was, beyond doubt, the place he was searching for with so much solicitude. Finally, he found it. It was a silken cord, the size and color of the wire, about one hundred feet long. The joints were made as the other wire, but covered with white paint, to resemble the solder.

#### NOVEL CASES OF REPAIRING THE LINE.

Col. Speed has reported a singular case of repair. A man had cut a tree, which, in its fall, broke the wire. He was anxious to mend it as speedily as possible. He was not able to get the ends together, and, as a substitute, he generously placed a rusty chain to complete the connection. Had the chain been bright, the line would have worked; but the dry rust be-

tween any one of the links was, perhaps, sufficient to prevent the passage of the electric current. The repairer passed the place several times without seeing it. Finally, however, the chain was discovered; and on telling the man who placed it there that it had interrupted the communication over the wire, he responded, that it could not be possible, for the chain was much *stronger* than the wire.

Another case has been reported to me by Col. Speed, where the fault baffled for days the greatest energy for its discovery. On many of the lines brackets are nailed to trees; the wire passing through one of these brackets, which had been nailed to an elm tree, touched the head of a nail, thereby causing an earth connection with the sap of the tree. Sometimes, by the force of the wind, the wire was removed from the nail, and then full communication was restored.

A case has been reported to me by Mr. Talcott, of the Washington station, where the repairer found the wire broken, but was unable to get the ends together. He was some twenty miles distant from a station; and for a temporary substitute, he purchased a stove-pipe. After perfecting the metallic connection between the sections of the pipe, he fastened it to the line wires, and communication was restored.

On one occasion, when repairing a break in the line, I was unable to get the ends of the wire together. Only one foot was needed. In this dilemma I lashed the iron climbers hereinbefore described, and by using them a good metallic connection was made, and communication over the wire restored.

On another occasion, I had not line wire sufficient to unite the ends. About five feet were needed. I cut a small pole, some two inches in diameter, and tied the ends of the wire to the pole. When in practical telegraph service, it was my custom to carry in my pocket some fifty or a hundred feet of the fine wire taken from the rejected relay magnets. With this fine wire I connected the line wires, lashing it around the pole, to prevent it from being broken. This fine wire perfected the metallic circuit, and communication was continued over it until a piece of large wire could be substituted for it, which was done on the next day.

It was my practice to use this small wire in connecting the ends of the wire, the moment I found the break, or before I cut the line wire, when that formality had to be resorted to. By that means, the line was brought into immediate use, long before the line was properly mended. In my administration of the telegraphs, I always found it advantageous to provide the repairers with more or less of this small wire.

Numerous cases might be cited showing ingenious remedies resorted to, in order to perfect the line sufficient to secure the transmission of dispatches temporarily. The cases cited prove the necessity of the employment of men for repairers capable of meeting cases in any emergency.

Having thus lengthily discussed the first duty of the repairer, I will now briefly consider the others; and as to the second,—*to remove from the line all foreign conductors.*

The repairer of the line should be very careful to remove from the wire all limbs of trees, and everything else, so as to have the wires suspended from the insulators, and nothing else. In cities I have often seen kite-strings fastened to the different wires, by which, when wet, the electric current passes from one wire to the other. This should not be the case under any circumstances. These strings may lead off the whole current, thereby preventing communication. An impression is very often entertained by operators, that their batteries will “drive over” the string conductors. This is possible in certain cases, such as where the batteries are near the difficulties. But, suppose the battery is one hundred miles distant, and a heavy rain falls, a stream of water will run from the upper wire to the lower along the kite-string. When this is the case, communications on either wire at the same time will be interrupted. When the like occurs, the remedy is only to be found in detaching one of the wires from the earth circuit, leaving the end at the station suspended in the air. If the string conducts the current from wire No. 1 to No. 2, and the latter is disconnected as above stated, communication on No. 1 will be uninterrupted.

Great care should be observed to preserve the wire from contact with nails, sides of trees, houses, and other things. Through the Southwest, young trees grow so rapid, that they need to be cut from beneath the line in the fall of every year.

And, thirdly, *to preserve a proper insulation of the wire.*

With reference to this subject, I would refer the reader to the article on insulation. Whatever the insulator may be, care should be observed to keep it in or on every pole. I have known lines to work tolerably well with many of the insulators out of the poles, the wire resting upon the wood. This ought not to be the case. The line will work as long as it is dry, but as soon as the wood is wet, the line will not work. A good and faithful repairer will, at any time, travel five or ten miles to place in the pole a single insulator. Nothing in the art of telegraphing is more important than a perfect insulation. Suppose the iron hook insulator be used, if the glass be broken, and a rain falls, it will be impossible to communicate over the wire.

In a word, the repairer should see that the wire is insulated by a non-conductor from everything that is a conductor throughout the whole line.

Fourthly, and finally—to secure the permanency of the structures of the line.

On every line of telegraph, some of the poles will decay before others. When such cases occur, new poles should be substituted without delay. If they are permitted to remain, the wind will sooner or later level them to the earth. Communication will then be interrupted, perhaps for a day or more, until the poles are replaced by others. As a question of economy, no one can doubt but what it will be much better to replace the decayed pole before its fall, bringing with it to the earth the wire, and interrupting communication.

It is often the case, that the water settles around the foot of the post, and, the earth yielding to the pressure, the pole bends over, or perhaps falls. The repairer should watch for such cases, and immediately rearrange the earth around the pole, or place stones around it, or drive small pieces of timber into the loose earth, to make it more compact, and to serve as braces to the pole. On lines using the open or groove insulator, it often occurs that the strain of some half mile of the wire will be on a single pole, placed at an angle. When this is the case, the pole is sure to bend or warp, and perhaps force through the earth. In such contingencies, the wire on the next poles, on each side, should be keyed, so that the strain upon the one pole will not be more than the two stretches.

I have now sufficiently explained the duties of a repairer. If what I have said be properly studied and practised by those employed in that particular service, I think the lines will be benefited, their economy will be subserved, and the public good will be greatly promoted by the increased facilities for telegraphing.

On lines where there are not employed special repairers, a corps of men should travel over the whole route in the spring and in the fall, and perfect the line in every particular, as herein before mentioned. This should be considered by every company as indispensable.

There are many telegraph lines in America, built with galvanized wire. Some telegraphers are of the opinion that the joints made of this wire do not require to be soldered. Such, too, was the opinion among practical telegraphers fifteen years ago, in regard to the ordinary wire not galvanized.

Complaints are made against soldered connections on galvanized lines, because the wires break oftener at the splicings than

elsewhere. Such was the case with the egg joint, and telegraphers objected to soldered connections at that time for the same reason. Some lines were then built without soldering any of them. In a few years they worked better during and after a rain than they did on dry days. This resulted from the water resting in the cavities of the wire joints, serving as auxiliary conductors. When they were dry, the rust was an inferior conductor, and hence the difficulty of getting a sufficient flow of the voltaic current from station to station. Even the dews of heaven that fell during the shades of night, served as rich blessings to the wearied operators, and as an amelioration to the struggling messenger destined for other climes! It seemed to me as though the finger of the Creator benignly aided in the perfection of the means for the transmission of that mysterious imponderable agent, which conceals itself, and nestles in the gorgeous drapery of his throne—a power in nature so transcendent in sublimity, that it can have no twin!



# IMPROVEMENTS IN TELEGRAPH APPARATUS.

## CHAPTER LII.

Kirchhof's, Farmer's, Hughes', Partridge's, Baker's, Coleman's, Channing's, Smith's, Clay's, Woodman's, Humaston's, and Wesson's patented improvements in telegraphing.

### PATENTED TELEGRAPH IMPROVEMENTS.

Among the many improvements invented within the past few years, and patented in the United States, are the following. Some of them are in use, and others have never been successfully applied to any of the telegraphs. The engravings are but outline representations of the respective inventions, but they are sufficiently distinct to enable the telegrapher to comprehend the speciality of the patented improvement. In presenting the explanations of the engravings I have omitted much of the detail embraced in the letters patents on record at Washington. I have copied the special claims in the respective patents, with a view that other inventors may know to what state the art of telegraphing has attained in mechanical combinations.

#### I. IMPROVEMENT IN ELECTRIC TELEGRAPH.

*Patented April 15, 1856, by Charles Kirchhof.*

By the movement of the hand  $w$  the stud  $o''$  is caused to slide the frame  $\gamma$  far enough to insert the arm  $d$  of the lever  $d d'$  in the notch in the catch  $c'$ , whereby the arm  $d$  is caused to partake partially of the movement of the armature  $\kappa \kappa'$ , and to be withdrawn from contact with the ivory piece  $w w'$ , and to carry the knee-lever past the line of culmination of the axle  $d''$  and the point  $u'$ , so that the power of the spring  $u$  may throw it against the block  $w$  or  $w'$ , and reverse the position of the shuttle and hold it fast. The index is stopped by means of a watcher  $h$  and waker  $l$ . The waker rotates with the spindle  $\tau$  and index; and if the hook  $l'$  meets with any obstruction,

it is swung sidewise, and the semi-circular part  $l''$  is thrown upward, and the collar  $m$  is thereby raised and caused to raise the fork  $i$  of the watcher-key  $h$ , and thus to break the circuit which passes through the watcher, the pin  $h'$ , and the plate  $g$ .

The hook  $l'$  is obstructed by means of the elbow-levers  $v$ , which are connected with the knobs  $x$ .

The inventor says: I do not claim any part or arrangement with the use and result thereof, as far as already well known and clearly specified.

But I *claim*, 1st, the prevention of the too early intermission or restoration of the circuit in the use of self-intermission, through the method by which a key-shuttle  $q$ , or its equivalent, is not only stationary during the whole travel of the armature  $\kappa$   $\kappa'$ , but also for a certain time afterward, so that the circuit, during that time, remains either permanently broken or closed; but afterward this shuttle is started and shoved by the indirect influence of the motion of the armature through some devices, till to the moment of breaking or restoring the circuit, and here stopped; and the armature, and by that all oscillating mechanical parts, are obliged to reverse immediately.

2d. The manner of stopping the index of all instruments of a circuit right opposite the desired letter, without disturbing or preventing the index, armature, or shuttle of any instrument to complete their adopted motion, by means of a "watcher"  $h$  and "waker"  $l$ , operated by the revolving hook  $l'$  and the key-lever  $v$ , or its equivalent, in the manner specified, so that the watcher will keep open; meanwhile the shuttle makes contact, whereby the indices stop until the key is relieved and the watcher closes again.

3d. The method to keep all instruments of a circuit in unison working, and without any mechanical means, through employment of "the induction current," by retarding the influence of the electro-magnetic power at a certain degree upon that instrument which intermits the circuit, and whereby the other instruments of the circuit not having their intermitters in activity, are governed by it, and insured to complete their motion before the circuit of the prime current is intermitted or restored again.

The said induction current in each instrument being used in connection with some suitable means for connecting and disconnecting the self-intermitter with the armature lever, and also with a means for closing and opening the induction circuit, and for the opening and closing of the accommodation course of the prime current, which act together at once, answering simultaneously their different purposes.

I.

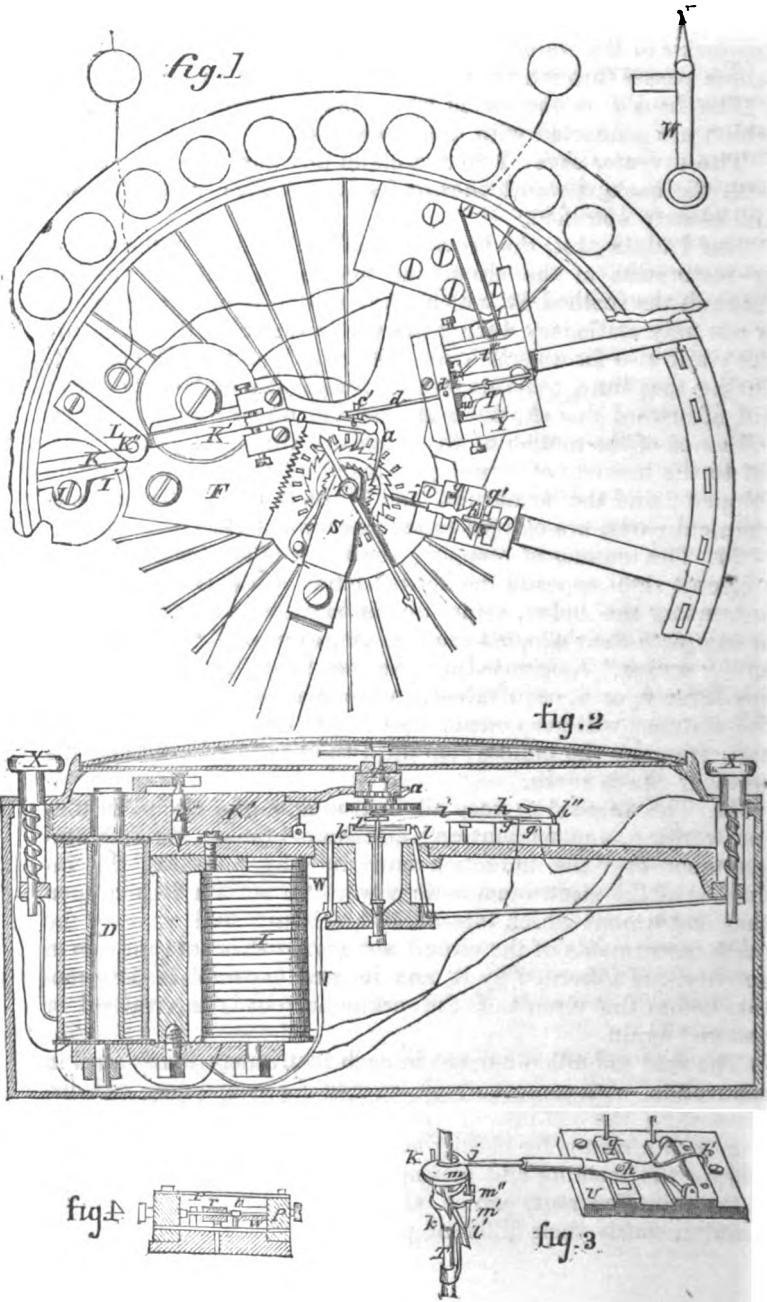

II. IMPROVEMENT IN TELEGRAPHIC REGISTERS.

Patented January 29, 1856, by Moses G. Farmer.

The engraving shows the connection of the main circuits. A represents the screw-cup which receives one main wire; the course of the current is through the main circuit magnet  $m'$  to the anvil  $a$ , spring  $s$ , and by wire  $w$  to the screw-cup  $g$ , which is in connection with the ground. The cup  $b$  receives the other main wire, and its course is through the magnet  $m$  to the anvil  $a'$ , spring  $s'$ , by  $w'$  to the ground  $g$ . The main circuit  $B$  will be opened by the movement of the armature lever of the local magnet  $L'$ ; if  $L'$  is charged, its armatures will lift the spring  $s'$  from the anvil  $a'$ , and thus break the circuit  $B$  at that point. Similarly the circuit  $A$  can be broken at  $a$  by the motions of the armature lever of the local magnet  $L$ .

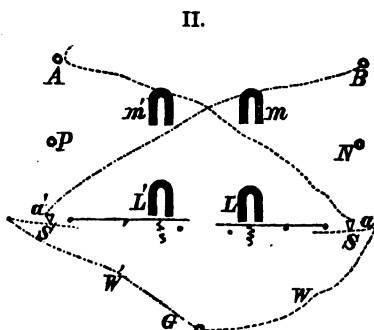

The inventor says: I am aware that a telegraphic register, operating upon the same general principle as mine, has been invented at an earlier date by Elisha Wilson, of New Haven, Connecticut. In his machine, however, the local circuits are both closed, while in mine the local circuits are similarly both open when the main circuits are both closed. The same work which in Wilson's machine is done by the closing of the local circuit, is done in mine by the opening of the local circuit, and *vice versa*. The general plan, therefore, in which my machine agrees with Wilson's I do not claim; neither do I claim simply substituting the breaking of the circuit for the closing to do the same work.

But what I do *claim* is, that modified combination of parts by which, in the self-acting telegraphic repeater, as described, the breaking instead of the closing of the local circuit is made to close the main circuit, and by which, throughout, the breaking of the local circuit is made a substitute for the closing.

III. IMPROVEMENTS IN PRINTING TELEGRAPHS.

Patented May 20, 1856, by David E. Hughes.

The nature of this invention will be understood from the claims and the engravings.

The inventor says: I do not claim any feature of any exist-

ing printing or marking telegraph as any part of my invention, nor do I desire to interfere in the least with any heretofore invented.

III.

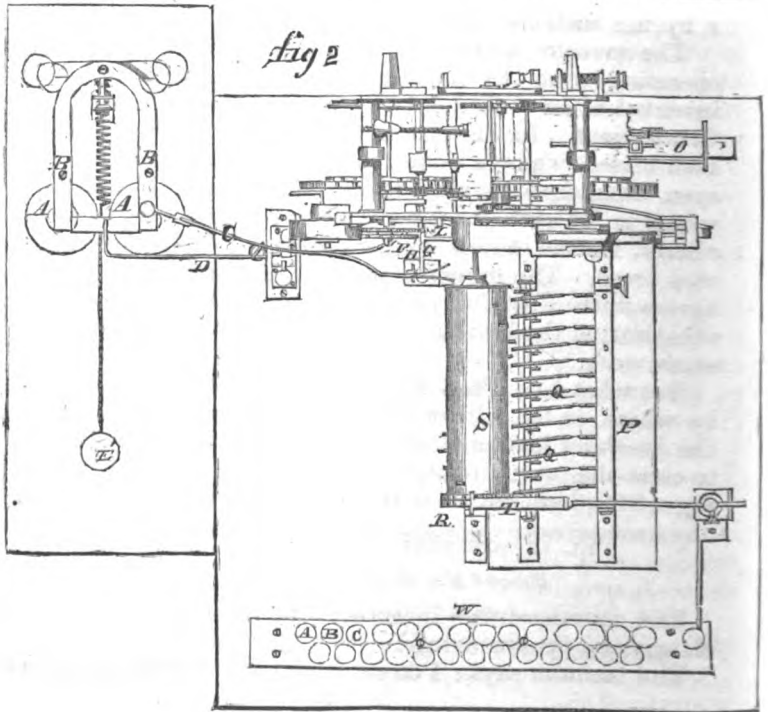
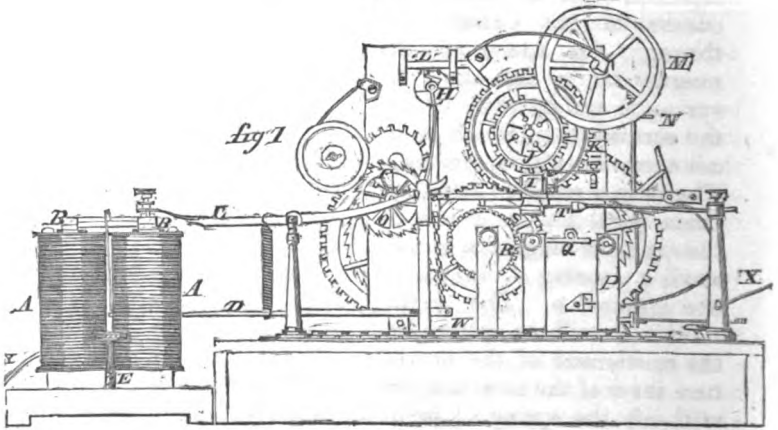

But I *claim*, 1st, the holding in place of the attractive power of electro or natural magnetism as applied to the telegraphic purposes, whether the same be applied in the manner herein described, or in any similar manner producing like results.

2. Particularly I *claim* combining with the permanent magnet *B* an adjustable spring almost sufficient to sever it from its contact with the soft iron of the electro-magnet *A*, and a lever *D*, or its equivalent, which, after the permanent magnet has been separated from the iron by the action of a current, shall bring it back again into renewed contact by the action of the power which has been called into action by the retreat of the magnet.

3d. I *claim* the employment of two cog-wheels or circuit-breakers *R S* at each station, so arranged that one shall be in connection with the electro-magnet at the same station, and the other in connection with the transmitting cylinder at that station, the whole being arranged so that the connection alternates at each station for every letter between the electro-magnet and the transmitting cylinder at that station, in such manner that the through connection is always simultaneously through the transmitting cylinder of one station and the electro-magnet of the other station, whereby the machine at each station can at the same time be transmitting a message and receiving a message; it being understood, however, that I do not *claim*, in general, the use of a single wire for the simultaneous transmission of different messages by means of rapid changes of connection, which is not new, but only the peculiar manner as above *claimed*, in which I have applied it in connection with my machine.

4th. So arranging a bolt *L* and operating the same by a cam, or its equivalent, that it shall act upon a wheel attached to the shaft of the type-wheel *J*, so as to preclude the intelligence from one station being communicated to any other station or stations on the circuit from which it is desired to withhold the communication.

5th. I *claim* the employment of a vibrating spring *O*, properly weighted at its extremity, if necessary, and so arranged by a series of mechanism as to govern and regulate the movement of the type-wheel *J*. This I *claim* also as a governor in other machinery, without limiting its use to its connection with electro-magnetism.

6th. I *claim* printing by electro-magnetism, by a continuously moving type-wheel, printing while in motion.

7th. I *claim* the arrangement of a cylinder *S*, with pins spirally arranged thereon, to operate by contact with metallic points

to close and break the circuit, when this is combined, for the purposes herein set forth, with the systems of keys *w*, &c., and catches, so arranged that any desired point may be thrown into a position where it will be retained until it is struck by its corresponding pin.

IV. IMPROVEMENT IN SELF-ACTING ELECTRIC TELEGRAPHS.

Patented July 12, 1856, by Moses G. Farmer.

When neither station is transmitting, the switch *s w* of each instrument is turned into the position represented in dotted lines in fig. 1. The current then passes from the screw-cup *A*,

IV.

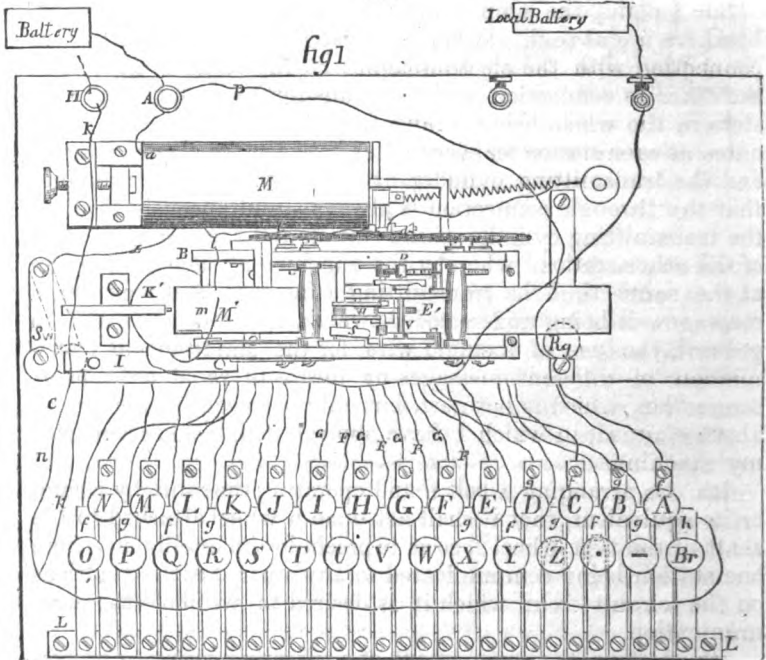

through the magnet *M*, by the wires *c* and *z*, to the switch *s w* and bar *I*, thence by the bar *I*, key *B r*, anvil *h*, and wire *k*, to the screw-cup *H*; the current not passing through the circuit-wheel is not broken, and the magnet remains permanently charged. When the operator at one end desires to transmit, he moves his switch *s w* into the position drawn in full in fig. 1, by which the current is thrown through the circuit-wheel of his machine; whereby the circuit is made and broken, and the armatures of both magnets are set in operation, and the circuit-

springs, letter-wheels, and printing-wheels of both instruments revolve together. The operator at the transmitting station then sends his message through the keys A B C etc., the current passing through the transmitting instrument as follows: from the

IV.

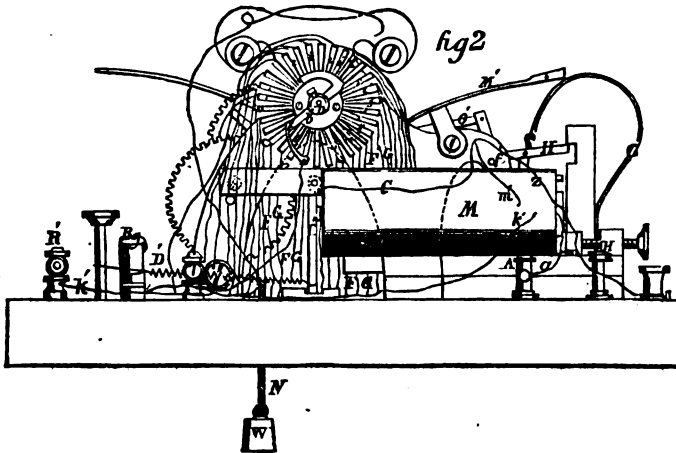

screw-cup A, by M C B D d, segments i or i, wires F or G, to the bar L, and by the key B r and wire k to the screw-cup H. Through the receiving instrument it passes from the screw-cup A by the magnet M, thence by the wires c and z to the switch s w and bar l, and by the wire n to the bar L, back to the screw-cup H, as before.

The inventor says: I do not claim arresting the motion of the type-wheel by a positive stop upon the key which interrupts the motion of the wheel whenever a key is depressed and at a moment when the circuit is broken, as in the telegraph of Seimens and Halskie.

But I claim the method described of arresting the motion of the type-wheel by means of the alternately open and closed keys, in combination with the circuit-wheel, constructed and operating in the manner substantially as set forth.

2d. I claim the combination of a straight key-board with a circuit-wheel, when the two are connected together by means of the wires F and G, whereby the place of making and breaking the circuit may be transferred to the immediate vicinity of the key-board, for the purpose set forth.

3d. The method described of putting the two machines in correspondence with each other, the current being turned out of the operating magnet M of the receiving machine by means



of the regulating key  $r$   $g$ , the arm  $b'$ , insulated spring  $c''$ , and their connections, operating in the manner set forth.

V. IMPROVEMENT IN ELECTRO-MAGNETIC PRINTING TELEGRAPHS.

*Patented April 22, 1856, by Albert J. Partridge.*

The branching of the circuit takes place between the pillar  $p$  and the pin  $y'$ . To the pillar  $p$  is pivoted a metal arm  $s$ .

IV.

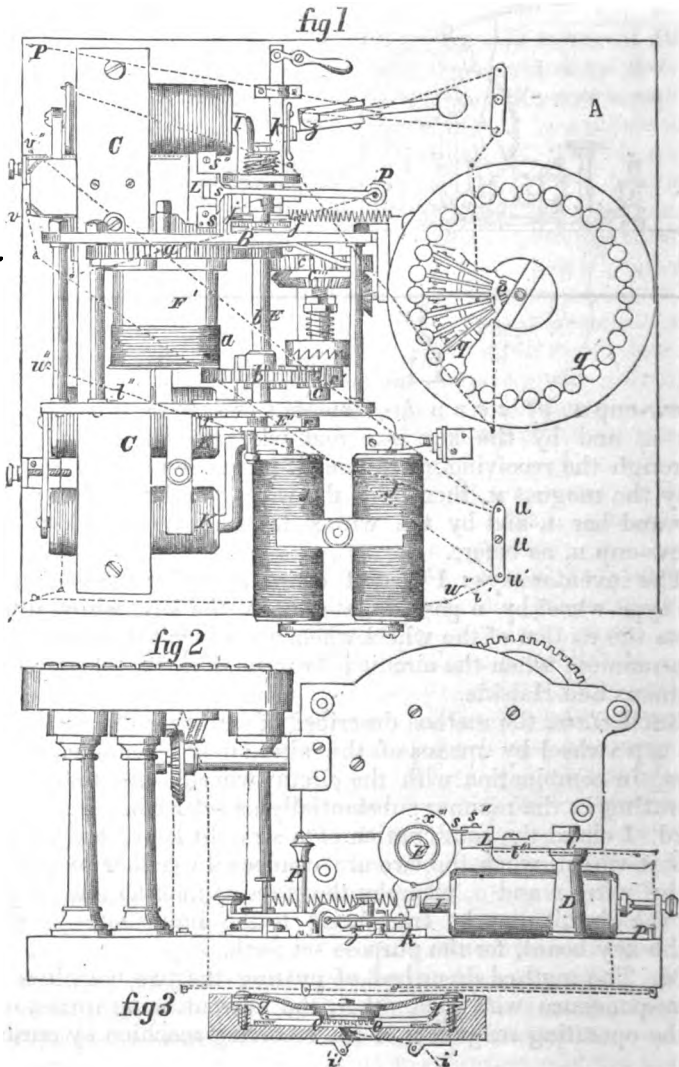

which has a r shaped extremity, which is capable, by a slight vibrating movement, of entering a slit in either of the two small brass blocks  $s'$   $s''$ , which are secured to a slab  $L$  of ivory. To the block  $s'$  is connected a wire  $t'$ , which leads along one side of the slab  $L$  and down through a hole  $i'$  in the base  $\Lambda$  and then to a pin  $w'$ , and thence up through a hole  $w'$  to the helix of the magnet  $J J$ . To the block  $s''$  is connected a wire  $t''$  which passes through a hole  $v''$  in the base, and then across to a pin  $w''$  and thence up through a hole  $w''$ , to connect with the helix of the magnet  $K K$ .

While the revolution of the type-wheel  $E'$  continues, there is no perceptible movement of the loose piece  $x$  of the clutch along the shaft, and the spring  $x''$  holding the said piece  $x$  closely engaged with the piece  $s'$  causes the circuit-changer  $s$  to remain in contact with the block  $s'$ ; but when the type-wheel shaft is suddenly arrested by the depression of a key-bar lever, the loose part  $x$  by the inertia of the fly-wheel  $x''$  moves far enough along the shaft to move the circuit-changer into the slit in the block  $s''$ ; thus, without breaking the circuit, the circuit is transferred from the magnet  $J J$  to the magnet  $K K$ , and the printing and feeding movement of the paper effected. But this change of circuit is only momentary; for as soon as the momentum of the fly-wheel  $x''$  is spent, the spring  $x''$  forces back the part  $x$ , and returns the circuit changer to the block  $s'$ .

The operator, by depressing the knob of either of the key-levers  $q q$ , throws up the inner end of that lever (as shown in fig. 3) to such a position that the revolution of the circuit-breaker  $e$  will bring the projection  $e$  in contact with it, and thus cause the circuit-breaker to be arrested. The arrest of the circuit breaker of the sending instrument stops the operation of the whole of that instrument, and also prevents the action of the escapement of the receiving instrument, and consequently stops that instrument also, and thus causes the change of circuit to take place in the manner before described through the momentum of the wheel  $x'''$  acting on the clutch.

*Claim.*—The mode of operating the circuit-changer  $s$  to change the circuit by means of the clutch  $x$ , and fly-wheel  $x'''$  attached to the loose part thereof.

VI. IMPROVEMENT IN ELECTRO-MAGNETIC PRINTING TELEGRAPHS.

*Patented April 29, 1856, by Henry N. Baker.*

The wire 13 connects with the metal plate 14, which is provided with two spring keys 16 and 17. The wire 12 passes



wheel magnet not having been opened when the movement of the lever *g* takes place, and the type-wheel consequently only having moved half the distance necessary to bring a new type between the tongue *p* of the lever and the roller *r*, causes the tongue to fall into a space between two types and thus renders it inoperative, but yet allows the movement of the roller *r* to take place to feed the paper. By keeping the key 16 closed, and closing and opening the key, a space of any desired length may be produced; but for the spaces to separate the words, the key 16 needs only to be kept closed during one closing and opening movement of the key 17, after which it may be played as before to move the type-wheel.

*Claim.*—The arrangement of the type-wheel *c*, the escapement wheel *i* attached thereto, the arrangement of the crutch or detent *j j*, acting upon the said escapement wheel relatively to the armature of the type-wheel magnet *e*, and the arrangement of the whole relatively to the tongue *p*, by which the types are lifted up into contact with the paper—all in such a manner that when the circuit is closed through the type-wheel magnet the tongue *p* will be opposite a space between two letters, and when, during the closing of said circuit, the circuit by which the said tongue and the feed-rollers are acted upon is closed, the tongue will be inoperative, and the feed-rollers allowed to act without any impression being given, thereby producing a space between the printed letters or words, substantially as herein set forth.

#### VII. IMPROVEMENT IN RECEIVING MAGNETS FOR TELEGRAPHS.

*Patented April 22, 1856, by Andrew Coleman.*

The curved form of the faces *a a* of the poles of the magnet *A* and of the armature *B* allows the armature to rock or roll, and hence to be converted into a lever with a changeable fulcrum. The finger *g*, which, playing between *h* and *h'*, opens and closes the circuit, is pivoted to a small stand *k* secured to the top of the armature, and sufficient friction is produced between the stand and the finger by means of a screw and nut on the pivot, and a small spring *l*, to overcome the inertia of the finger and cause it to move with the armature until it is arrested by either of the screws *h h'*, after which it allows the armature to move independently of it.

*Claim.*—So constructing or arranging the armature *B* and applying the spring *e*, or its equivalent, that the armature constitutes the whole or part of a variable lever, which causes the effective force of the spring, or its equivalent, to increase or

diminish as the magnetic force becomes greater or less ; when this is combined with the so applying the finger *g*, by which the local circuit is opened and closed, that the said finger is caused to move with the armature by friction only, or its

## VII.

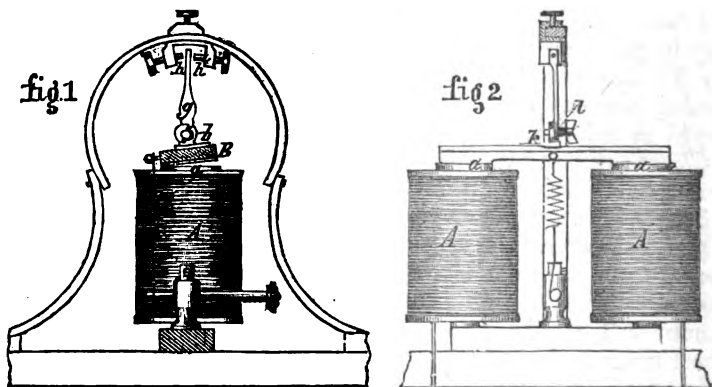

equivalent, and, after having moved the slight distance necessary to open or close the circuit, leaves the armature free to move as far as necessary independently of it, thereby obviating the necessity of manual adjustment of the armature to compensate for variations of magnetic force.

## VIII. IMPROVEMENT IN FIRE-ALARM TELEGRAPH.

*Patented May 19, 1857, by William F. Channing and Moses G. Farmer.*

If a fire is discovered in the vicinity of a signal station *z*, an authorized person opens the signal box, and turns crank *a'* a number of times ; the teeth *b' b''*, on the circuit wheel, depressing the key *c' c'*, and in this manner break and restore the circuit at definite intervals, the key returning by its own elasticity ; this operation causes the electro-magnet and armature of the central station *v*, by repeated strokes on *r*, to indicate the number of the district and station whence the alarm designates. The operator at the central station *v*, by turning crank *A*, operates the transmitting apparatus, *A B*, causing the bells at the alarm station *v*, to give the alarm, and, by tapping on key *m' m''*, the number of the signal station originating the alarm may be transmitted to any of the signal stations, *z*.

VIII.

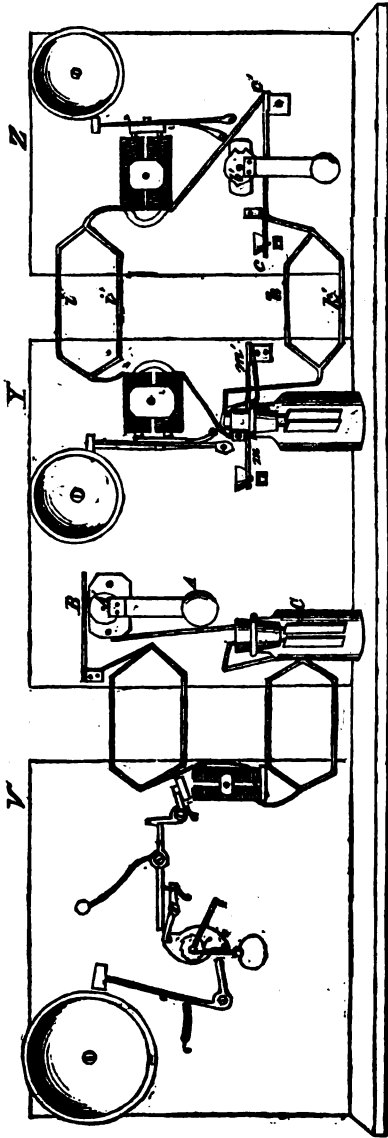

*Claim.*—1st. The signal system described, consisting of a series of signal stations scattered at intervals through a whole city or town, or any part thereof, and telegraphically connected with a common centre or point, or with each other, by one or more signal circuits, by which means a constant communication may be established and maintained, between all parts of a city or town, however extended; and with the centre or centres, at which the signal circuit or circuits converge or meet, so that the moment the fire occurs, its existence and locality may at once be known at the centre of the system, and efforts for subduing it properly directed.

2d. The alarm system described, consisting of a series of alarm stations, suitably distributed throughout a whole city or town, or any part thereof, and telegraphically connected with a central station, by one or more alarm circuits, by which means a public alarm of the existence and locality of a fire, may be given at different points.

3d. In combination with the alarm system, for striking the number of the district upon the alarm bells, the signal system for communicating the number of the station at which the fire occurs to all the signal stations, as well as for communicating an alarm to the central station.

#### IX. IMPROVEMENT IN TELEGRAPHIC REPEATERS.

*Patented August 18, 1857, by John E. Smith.*

A detailed description of this invention would take up too much space to be given here; the principal features thereof will be understood by reference to the claims and engravings,

The inventor says: I do not claim the opening and closing of the local circuit by magnetism produced by the opening and closing of the main circuit.

But I *claim* the connection of a battery at each station with the line wire, and with two local cross connections, in such manner that, by means of the key and relay lever, the cross connections through the register magnet, and the other cross connections, are alternately broken, and the battery thrown upon the main line, and its current caused to operate the relays on the line wire, like a main current, till shut from the line by the relay lever, as described, whereby each battery is made to perform the duty of an ordinary local battery, while not wanted on the line wire, and to perform the duty of a main battery while not wanted as a local.

2d. The key placed in the local circuit and constructed, as described, to open and close the said circuit in two branches, to give two directions to the current over the line wire, substantially as and for the purpose set forth.

IX.

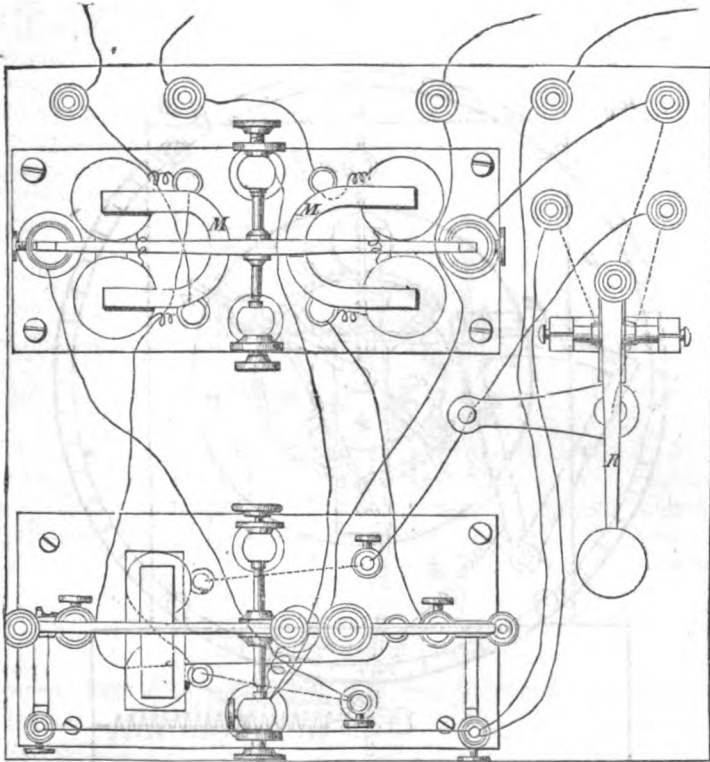

X. IMPROVED DEVICE IN TELEGRAPHIC FIRE-ALARM APPARATUS.

*Patented November 17, 1857, by Edward C. Clay.*

In operating this invention, the operator at the central station, having received the alarm from one of the minor stations, sets the hand *F*, at 60, and the hand *E*, at the number of the district in which the fire may be (say at 2) this places the snail *K*, in the position shown in the engraving; when the pin *e* will strike against the second step, on the periphery of the snail *K*, and allow the escapement *i* to be drawn over by its springs *d*, in the direction of the arrow, just so far, that it will require to be fed up two notches by the shaft *M*, before the pin *e* is again brought into the path of the arm, *l*; when this occurs, the revolutions of the shaft are arrested.

Having thus arranged the hands, the operator moves the key



X.

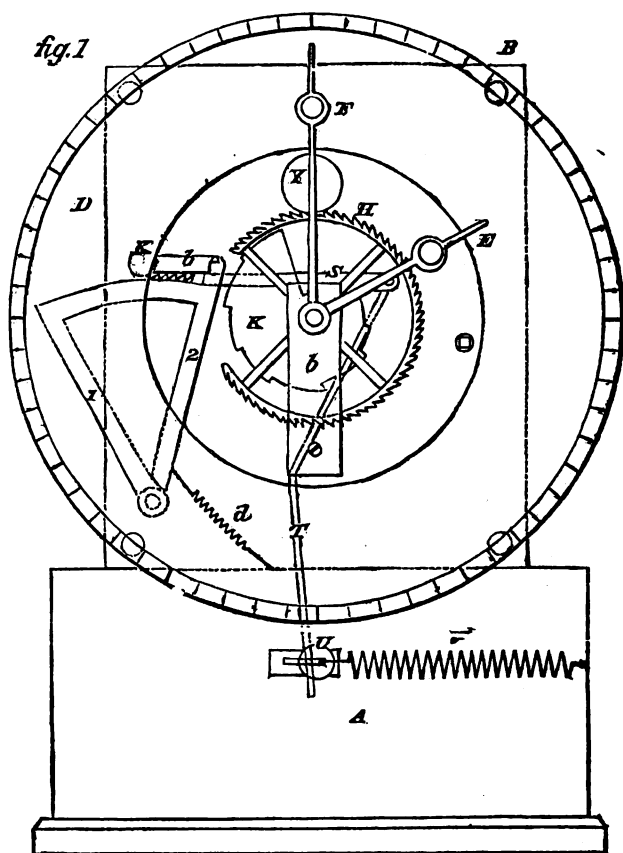

*v*, against the resistance of spring *v*; this moves the long bent rod *r*, and vibrates the lever *s*, and lifts the pin *n*, clear of the segment *f*, when the spring *d*, immediately draws the pin *e* near the escapement *i*, until the pin *e* rests against the snail *k*. As soon as the pin *n* has been lifted, and the escapement *i*, has vibrated, the key *v* is released by the operator, and the pin *n* falls again into the segment *f*, and acts as a retaining pawl. When the pin *e* is drawn out of the way of the arm *l*, the shaft *m* revolves. Each movement of the shaft causes the bells to

strike once, moves forward the index hand one mark, and feeds up the segment *f* one notch; now, as the position of the seg-

X.

fig 2

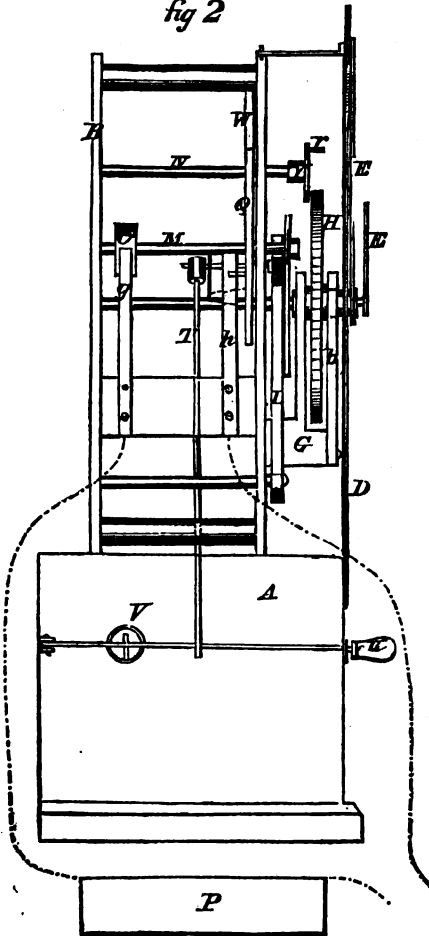

ment *f* is repeated by the index hand, the number of the district will be struck and counted, when the pin *e* will again be

brought into the path of the arm *l*, and the operation be stopped.

*Claim.*—The snail *κ*, or its equivalent, and dial plate, in combination with the single key *u*.

#### XI. IMPROVEMENT IN TELEGRAPHIC REPEATERS.

*Patented March 17, 1857, by Moses G. Farmer and Asa F. Woodman.*

In engraving, fig. 1, *A'' A'''*, two distant stations, this invention being supposed to be placed at an intermediate one. If the independent circuit be broken by an operator at *A''*, the re-

XI.

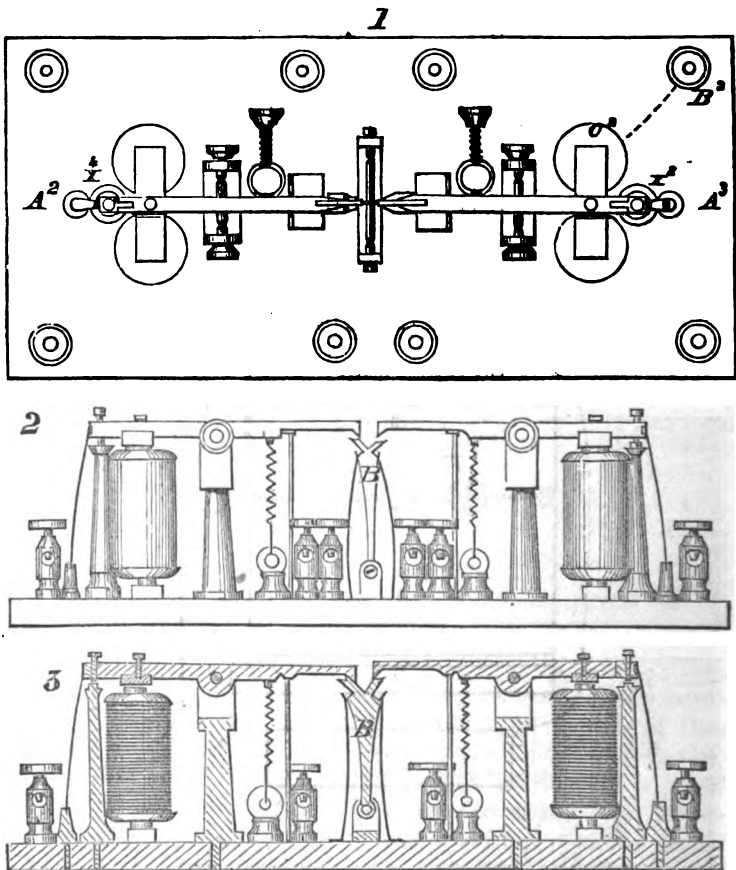

lay magnet at  $b''$  will be discharged, and this will discharge the local magnet at  $c''$ , and break the dependent circuit at  $x''$ . This will cause the lever  $b$  to be tipped, and thereby prevent the independent circuit being broken at the instrument, or at  $x'''$ . From this it will be seen that the main circuit, which is first broken (which may be called the independent circuit), determines which way the beam  $b$  shall incline, and that this inclination, while it allows the instrument to break the dependent circuit, prevents it from breaking the independent circuit.

*Claim.*—The use of a mechanical obstacle, essentially in the manner set forth, whereby, when the independent circuit has broken the dependent circuit at the instrument, the dependent circuit is prevented from breaking the independent circuit.

XII. PUNCHING PAPER FILLETS FOR TELEGRAPHIC SIGNALS.

*Patented September 8, 1857, by John P. Humaston.*

This invention will be understood by reference to the following:

XII.

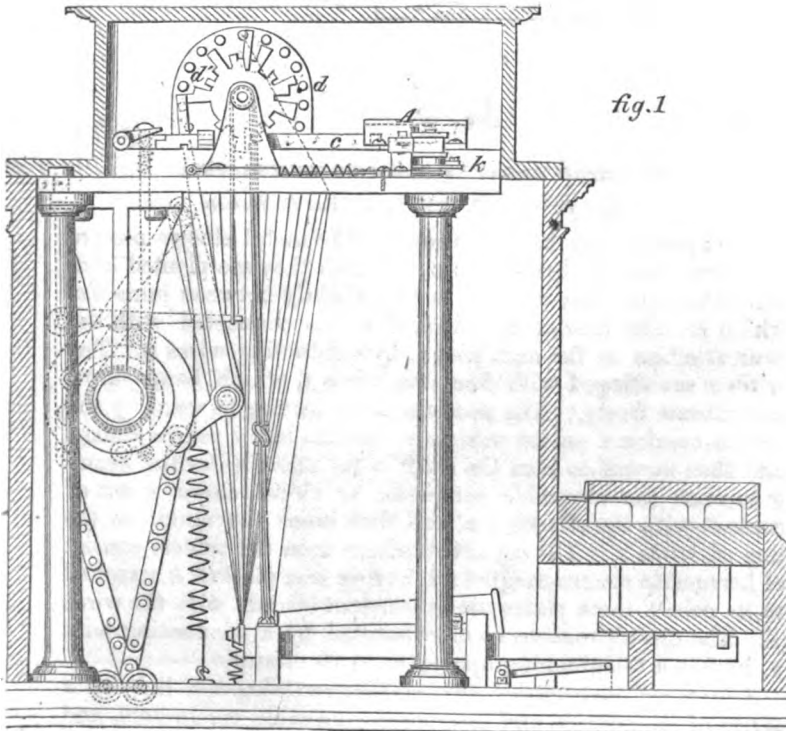

*fig. 1*

*Claim.*—First. The manner of operating the punches for perforating the characters in the paper, consisting of the revolving type-wheel, or other equivalent means of indicating characters, in combination with the punches, as described.

Second. The method of regulating the feed of paper, consisting of the graduated stop-wheel, or equivalent series of stops in combination with the type-wheel, and with the means for propelling the paper fillets past the punches, as described.

Third. The manner of forming the cutting ends of the punches—that is to say, having its advancing end formed into two cutting edges, by means of the V-shaped recess, in combination with a second pair of cutting edges opposite to them, formed in like manner and upon the same plate, but in position at a right angle to the first pair, thus making the other half of the shear, in conjunction with an adjoining punch substantially in the manner set forth.

## XII.

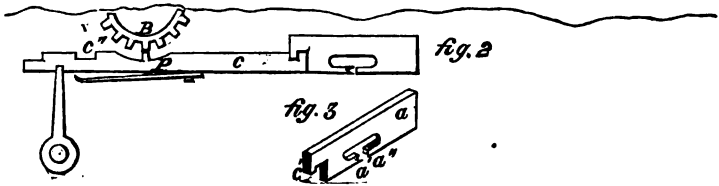

## XIII. IMPROVEMENT IN ELECTRIC TELEGRAPHS.

*Patented February 17, 1857, by William D. Wesson.*

A are posts along the whole road. The metal elbows D D are insulated from the brackets C B, to which they are pivoted at a. The elbows are only allowed to play slightly between jams b c, which are also insulated. Each elbow is connected with the nearest elbow on the next post A, by conducting wires E. The wires E are fringed with fine iron wires f, which hang down and vibrate freely. The pendulum I is swung forward by the circuit-breaker L on the vehicle v, (as the latter passes along,) and thus caused to turn the shaft G far enough for the crank g to raise the moveable conductor or circuit-closer H out of contact with the elbows D D, and thus break the circuit in the line of wires E. The circuit-receivers upon the vehicle consist of horse-shoe electro-magnet J J, having iron plates k k attached to its poles; these plates are in constant contact with the wires f. The circuit receivers are connected by a conducting wire y, having a telegraphing apparatus in its circuit.

*Claim.*—Constructing the stationary telegraph line of a series of immovable and interposed moveable conductors, and

XIII.

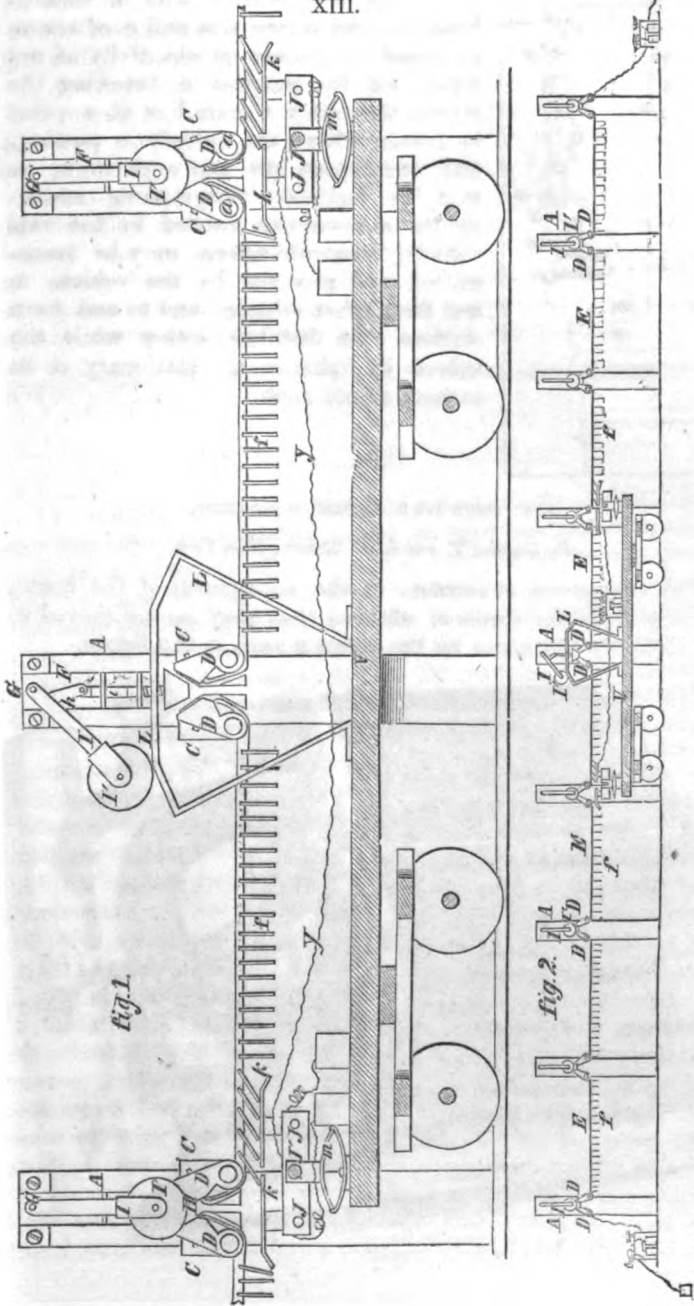

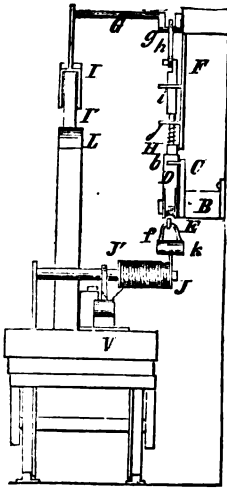

furnishing the vehicle with a circuit-breaker, circuit receivers and conductors, arranged to operate substantially as set forth, for the purpose of breaking the circuit through the main line at a point or points where the vehicle is passing, and completing the circle through, so that by suitable telegraphing instruments or apparatus carried by the said vehicle, communications may be transmitted and received by the vehicle to and from other vehicles, and to and from stations at a distance, either while the vehicle or vehicles are stationary or in motion, as set forth.

#### XIV. IMPROVED ELECTRO-MAGNET.

*By Charles T. and J. N. Chester, New-York.*

This improvement consists in the adjustment of the horse-shoe core and the spools of wire, so that they can be moved to and from the armature by the screw *p* seen in the figure.

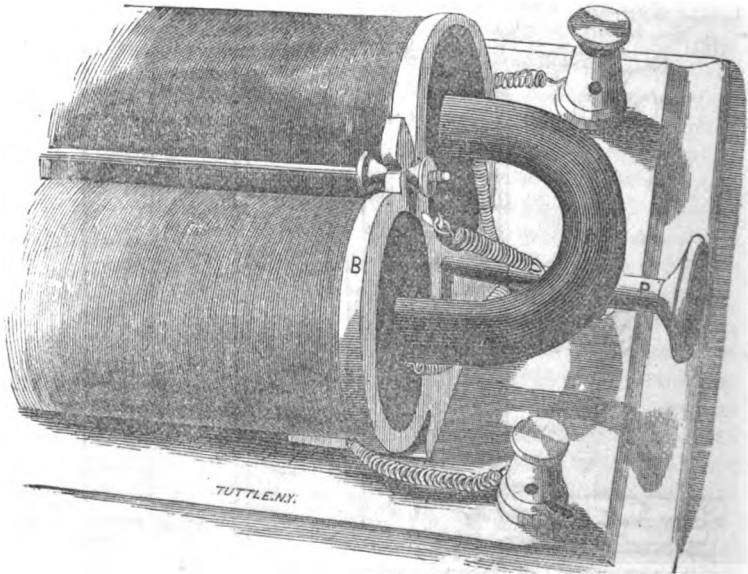

# ELECTRIC TIME-BALL.

---

## CHAPTER LIII.

Utility of Electric Time-Balls for Correction of Chronometers—Nelson's Monument and Time-Ball.

### UTILITY OF ELECTRIC TIME-BALLS.

In America, we have a National Observatory, and though it has had but a few years' existence, its fame has spread throughout the civilized world, and added new lustre to our glory; but we have no time-balls in our maritime cities, to indicate the hour and the movement of the pendulum at Washington, in our National Observatory.

In England, at an early day in the history of electric telegraphing, the science was employed as an auxiliary at the Greenwich Observatory, in the determination of longitude, the movements of the stars and other heavenly bodies, and for the diffusion of chronometer time throughout the country. The astronomer royal, in concert with the electric telegraph companies, announces an hour of each day, by the fall of electric time-balls from elevated positions, in different parts of the country. The moment the ball at Greenwich falls, those in other cities fall. There is one of these balls on the Strand, near Charing Cross, in London, and it serves a good purpose in the correction of chronometers, whether in the hands of the mariner, the merchant, or the manufacturer. Persons can regulate their own timepieces, without the aid of the watchmaker. Besides this arrangement for giving correct time, I noticed at Greenwich, an electric clock, in connection with the leading telegraph office in London, by wires; signals are transmitted from the observatory to Lothbury, the telegraph office, every hour of the day. The same signals are made at the office on the Strand before mentioned, and they are also sent to Dover, Tunbridge, Deal, and other places. At specific times



the hour is sent from the observatory to different parts of the country.

Correct longitudes have been taken simultaneously at Cambridge, Edinburg, and Brussels, by electric wires, communicating each with the other, and enabling the operators to communicate, as though assembled together. Greenwich, Brussels, and Paris observatories are placed in connection, through the submarine cables running across the channel, from Dover to Calais, and to Ostend.

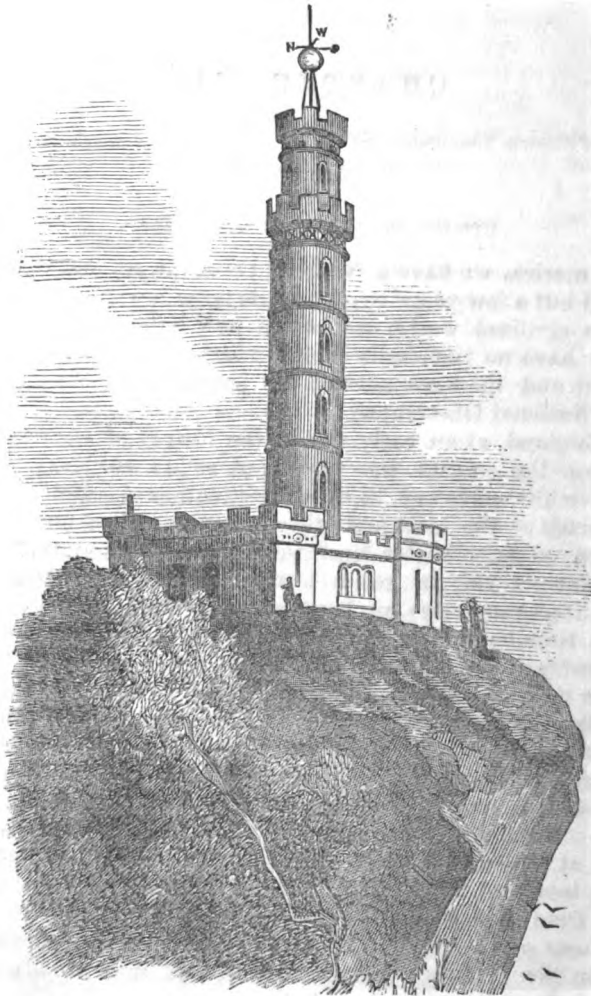

Nelson's Monument and Time-Ball.

## NELSON'S MONUMENT AND TIME-BALL.

On my first visit to Edinburgh, Scotland, in 1855, I was much gratified in visiting its ancient monuments, and the relics of by-gone centuries. There was nothing, however, that gave me more pleasure, than a visit to Calton-Hill, and viewing the scenery, spread out before me, from the top of the Nelson Monument. The great deeds of the intrepid Nelson, whose heroic fame, stands brilliant in the annals of Old England, served to make the spot sacred, on which the monument stood—elevated high above the city. While at the top of the monument, surveying the wide-spread scenery around me, embracing within my view the ancient castle, King Arthur's seat, Holyrood, the old city of Edinburgh, the surrounding bays and distant hills, I saw the time-ball descend. It was above me, and it appeared to be of immense dimensions. It was exactly 1 o'clock, P. M. It seemed to come down rapid, but noiseless. I looked at it in silence, and a thousand thoughts rushed upon me in rapid succession. It reminded me of the fleeting moments passing, never again to return, and that how soon, we frail mortals, would fall before the all-devouring scythe of Time! Besides these reflections, it gave me new powers in the appreciation of the electric telegraph, which to me has, from its commencement, been an enchanting theme. It was the electric time-ball, indicating the second, and the most minute division of time!

The following from the *Scotsman*, further describes this new stride in the sciences of the present century, viz. :

“ If the public look to the monument, at five minutes before 1 o'clock, P. M., Greenwich time (now Edinburgh time also), they will see the ball raised half-mast high ; at two minutes before, full mast high, or in contact with the cross-bars ; and, at 1 o'clock, exact to a tenth of a second, it will fall—the instant to be observed being the commencement of the fall, as shown by the formation of a line of light between the ball and the bars. Those who, on the monument, have witnessed the fall of the ball, describe the effect as extremely interesting. The huge mass is first of all seen rushing downward with terrific velocity, as if likely to carry all before it ; when, suddenly, at about three fourths down, it is brought, by some invisible agent, almost to a stand-still ; and then, with two or three slight movements up and down, it rests on its bed-block as quietly as if nothing had happened.”

On my visit to the top of Nelson's monument, I was accompanied by my family ; and I took much pains in describing the

particulars of the wide-spread scenery around me, to my son, then seven years of age, so that he might have them indelibly fixed in his memory. Three years subsequently, I asked him to tell me something that he had seen in Scotland, expecting, at the same time, that he would refer to the ancient castle, containing the great sword of state and the iron-framed crown of Bruce, or to Nelson's monument and the electric time-ball. He promptly responded, that it was the place where the boys played "leap-frog!" He had seen the boys thus playing at the foot of Nelson's monument.

# ORIGINATION AND ADMINISTRATION OF AMERICAN TELEGRAPHS.

## CHAPTER LIV.

Origination of Telegraph Lines—Organization of Companies—Charter—By-Laws—Office Regulations—Rules for Sending and Receiving Messages—Lines in British Provinces—Patent and Parliamentary Monopolies.

### UNITED STATES—ORIGINATION OF TELEGRAPH LINES.

THE telegraph lines in the United States of America are owned by many companies. Their construction has been consummated, in most cases, through a spirit of speculation, controlled by a few persons. There are but few cases, where regularly organized companies have taken the initiative. In most cases, individuals, in localities having a little knowledge of the developments of this wonderful means of communication, becoming infused with a zeal for the extension of a line to their towns or cities, have proceeded to negotiate for the patent rights to build and use a line of telegraph thereto from some specified point already connected by the line of another company. In many cases, persons have contracted for the patent for lines between places, having in view a profit on the construction of the line, and a sale of the patent at an advanced price to the company. An arrangement for the purchase of the patents has always been an indispensable preliminary. In order that the reader may understand the nature of a patent contract, I insert the following copy of the celebrated agreement made between Mr. Henry O'Reilly of New-York, and the patentees of the Morse Telegraph, viz. :

*Articles of Agreement for extending the Electro-Magnetic Telegraph, from the Seaboard to the Mississippi and the Lakes.*

This memorandum of an agreement between Henry O'Reilly, of the one part, and Samuel F. B. Morse, Leonard D. Gale, Alfred Vail, and Francis O. J. Smith, of the second part, witnesseth as follows :

That the said Henry O'Reilly undertakes, on his part, at his own ex-

pense, to use his best endeavors to raise capital for the construction of a line of Morse's Electro-Magnetic Telegraph, to connect the great seaboard line at Philadelphia, or at such other convenient point on said line as may approach nearer to Harrisburg, in Pennsylvania, and from thence through Harrisburg and other intermediate towns to Pittsburg, and thence through Wheeling and Cincinnati, and such other towns and cities as the said O'Reilly and his associates may elect, to St. Louis, and also to the principal towns on the Lakes.

In consideration whereof, the said parties of the second part agree and bind themselves, their representatives and assigns, that, when the said O'Reilly shall have procured a fund sufficient to build a line of one wire from the connecting point aforesaid, to Harrisburg, or any points farther west, to convey the patent right to said line so covered by capital in trust, for themselves and the said O'Reilly, and his associates, on the terms and conditions set forth in the articles of agreement and association constituting the "Magnetic Telegraph Company;" and providing for the government thereof, with the following alterations, viz. :—The amount of stock or other interest in the lines to be constructed, reserved to the grantors and assigns, shall be one-fourth part only, and not one half of the whole, on so much capital as shall be required to construct a line of two wires; but in all cases of a third wire, or any greater number, the stock issued on the capital employed for such additional wire or wires, shall be divided equally between the subscribers of such capital and the grantors of the patent right, or their assigns. No preference is to be given to the party of the first part and his associates in the construction of connecting lines, nor shall anything herein be construed to prevent an extension, by the parties of the second part, of a line from Buffalo to connect with the Lake towns at Erie; nor to prevent the construction of a line from New-Orleans, to connect the western towns directly with that city; but such lines shall not be used to connect any western cities or towns with each other, which may have been already connected by said O'Reilly.

In case of a sale of the entire patent right to the Government, the grantors shall be bound to pay the actual reasonable cost of the lines constructed under this agreement, with twenty per cent. thereon, and no more, to vest the Government with the entire ownership of such lines—provided, as specified in the articles of agreement of the "Magnetic Telegraph Company," the purchase be made or provided for by Congress before the 4th of March, 1847 (eighteen hundred and forty-seven).

The tariff of charges on the lines so constructed, shall conform substantially to the tariff of charges on the great seaboard line before named, and in no case to be so arranged as to render the lines unequal in this respect, to the prejudice of either.

Unless the line, from the point of connection with the seaboard route, shall be constructed within six months from date, to Harrisburg, and capital provided for its extension to Pittsburg within said time, then this agreement, and any conveyance in trust that may have been made in pursuance thereof, shall be null and void thereafter; unless it shall satisfactorily appear that unforeseen difficulties are experienced by said O'Reilly and his associates, in obtaining from the State officers of Pennsylvania the right of way along the public works; and in that event the conditional annulment aforesaid shall take effect at the end of six months after such permission shall be given or refused. And any section beyond said last point, embraced within the provisions of this agreement, which shall not be constructed by said O'Reilly and his associates, within six months after said parties of the second part shall request said O'Reilly to cause such lines to be constructed, so as to extend the connection at least one

hundred and fifty miles beyond said last point, and in like ratio during each succeeding six months thereafter—*then*, in relation to all such sections of the line, this agreement shall be null and void, provided that such request shall not be made prior to the 1st day of April next (1846).

And the party of the second part shall convey said patent right, on any line beyond Pittsburg to any point of commercial magnitude, when the necessary capital for the construction of the same shall have been subscribed within the period contemplated by this agreement, by responsible persons, and not otherwise.

Done at the city of New-York, this 13th day of June, in the year of our Lord eighteen hundred and forty-five.

HENRY O'REILLY,  
FRANCIS O. J. SMITH,  
SAM. F. B. MORSE,  
L. D. GALE (by his Attorney,  
S. F. B. Morse).

With a contract in the above form, the public is approached for subscriptions for stock in the company, to be organized under articles of association, or under a charter granted by the legislature of the State to be traversed by the telegraph. The association, or company, as the case may be, by its subscription for stock, sign a contract with the person holding the patent privilege, to construct the line and to deliver it, with the patent franchises, for the sum of three hundred dollars per mile—one hundred and fifty dollars per mile to be paid the contractor, in cash, for the building of the line, and one hundred and fifty dollars per mile, in shares, for the patents. These are the usual prices for the purposes respectively, throughout the United States. There are a few side or lateral lines, which have been built for half that sum. In such cases the cost of the patent has been about ten dollars per mile. The abundance of labor and timber often gives much profit at one hundred and fifty dollars per mile. As a usual rule, twenty per cent. is estimated for profit in the construction, leaving one hundred and twenty dollars per mile for the actual cost of the line. No line ought to cost less than this sum, and no line ought to be built without judiciously applying the money for substantial materials, so that the line will be permanent and serviceable. The proper application of one hundred and twenty dollars per mile, in most any part of the United States, can construct a line as substantial as the best pole lines in England, Denmark, Sweden, Russia, France, Belgium, Prussia, and the German States generally.

The length of a line owned by one company is, on an average, about 500 miles. There are some companies, however, extending double that distance. I will give a few examples, taking the lines running east and west, namely: from the eastern boundary of the United States to Boston, about

600 miles, is a line of two wires, owned by one company ; from Boston to New-York, about 250 miles, another line of five wires ; from New-York to Pittsburg, about 350 miles, another line of two wires ; from Pittsburg to Louisville, about 400 miles, another line of two wires ; from Louisville to St. Louis, about 300 miles, another line of one wire ; and from St. Louis to Leavenworth, about 360 miles, another line of one wire. These lines are owned by separate and independent companies. On some of these routes there are rival lines, one using the Morse patents and the other using the House, or others' letters patents. This state of things will most likely remain until the expiration of the Morse patents, when rival lines may be expected all over the country. As there will be no patent to pay for, the capital stock of the company can be less, besides the gain by economy in construction and the experience of the past.

#### ORGANIZATION OF COMPANIES.

After the line has been built, and supplied, by the contractor, with all the instruments for business operation, it is ready to be handed over to the association of stockholders. A meeting is formally called, by notice in the newspapers, to organize under the charter, and at which, the contractor tenders the line as completed under the terms of the contract. This contract, however, has been generally very indefinite, only requiring a well-built line, as compared with other lines in the United States. The stockholders, at their meeting, appoint a committee to inspect the line, who are generally previously informed on the subject, and forthwith a report is submitted, recommending its acceptance from the contractor. This done, the by-laws governing the proceedings of the company are adopted. Then follows the election of the yearly officers, consisting of a president, secretary, treasurer, superintendent, and directors. In some companies the first four officers are elected by the board of directors, and the president performs the services of superintendent ; in others, he is merely nominal.

I have now explained how lines originate, how the patent is negotiated for, and how the line is built and delivered to the company ; also, how the company proceeds until its organization in full for the management of the line, under the charter from the legislature of the State.

The charters of telegraph companies are much the same throughout the United States, differing only in the name and route of the line. As a form, I give the following, viz.

## CHARTER.

*Be it enacted by the General Assembly of the State of \_\_\_\_\_, as follows :*

Sec. 1. That \_\_\_\_\_ and their associates or assigns, who have acquired, or may acquire, from Prof. Saml. F. B. Morse, the right to use his Electro-Magnetic Telegraph, Chemical or Printing Telegraph System, by him invented and patented, upon the line hereby incorporated, are hereby created a corporation and body politic, for the purpose of erecting and managing a line of said telegraph, extending from \_\_\_\_\_ to \_\_\_\_\_ as the said \_\_\_\_\_ may elect, for the purpose of transmitting intelligence by means thereof, under the name and style of the \_\_\_\_\_ Telegraph Company.

Sec. 2. The shares of stock in said company shall be fifty dollars each, and to be issued to the owners of the patent right of the telegraph, and to the subscribers of stock in said line; said stock to be issued by the said \_\_\_\_\_, at the rate per mile as agreed to by them and the subscribers along the route, and be issued as the line progresses, to such persons as may be entitled to the same, according to the subscription agreement. The stock in said company shall be exempt from taxation, until a dividend is declared upon the same.

Sec. 3. As soon as the said line of telegraph is completed, a meeting of the stockholders in said line is to be held in the city of \_\_\_\_\_, to take charge and control of the line, and to elect a president and directors, and such other officers of the company as may be determined by the stockholders aforesaid; the said \_\_\_\_\_ are to give notice in one or more newspapers on said line, of the time of meeting, allowing thirty days to intervene between the call and the time of meeting. The stockholders, at their first or succeeding meetings, may adopt such rules and by-laws for the government of the company, as they may deem expedient: provided, such rules and by-laws are not inconsistent with the constitution and laws of this State, or of the United States.

Sec. 4. The Telegraph Company hereby incorporated, shall have power to sue and be sued, complain and defend, in any court of law or equity, having competent jurisdiction; to make and use a common seal, and the same to alter at pleasure; to purchase and hold such real and personal estate as the lawful purposes of the corporation may require, and the same to sell and convey, when no longer required for the legitimate purposes of the line.

Sec. 5. The \_\_\_\_\_ Telegraph Company shall have power to set up their fixtures along and across any of the roads, streets, or waters of this State, without its being deemed a public nuisance, or subject to be abated by any private person: the said fixtures to be so placed as not to interfere with the common use of such roads, streets, or waters, or with the convenience of any land owner, more than is unavoidable; but the said corporation shall be responsible for any damages that any person or corporation may sustain by the erection, continuance and use of such fixtures; and in every action brought for the recovery thereof, by the owner or possessor of any land; the damages to be awarded may, at the election of said corporation, include the damages for allowing the said fixtures permanently to continue, on payment of which damages the right of the corporation to continue such fixtures shall be confirmed, as if granted by the parties to the suit; provided, that no person or body politic shall be entitled to sue for or receive damages as aforesaid, until the same corporation, after due notice, shall have failed or refused to remove in a reasonable time the fixtures complained of; and such notice, to any agent of said company, shall be deemed a sufficient notice in the premises.

Sec. 6. The corporation shall be bound, on application of any of the



officers of this State, or of the United States, acting in the event of any war, insurrection, riot, or resistance of public authority, or in the prevention or punishment of crime, or the arrest of persons charged or suspected thereof, to give to the communication of such officers immediate dispatch; for the transmission of such communication, the company shall not charge any higher price than for private communications of the same length.

SEC. 7. The said company have power to sue for and recover damages from any person or persons who may break or interrupt the working of said line of telegraph, to the amount of the loss sustained by the non-working of the line, and its cost of repair, and in addition, a fine of three hundred dollars, as damages sustained by the company in the premises; and if any person or persons shall refuse, or omit to pay said damages, he, she or they shall be imprisoned in the county jail for a term not less than six months, nor more than one year, as may be determined by the court or jury by which the cause is tried.

SEC. 8. No person shall act as operator, to send forward and receive any message or dispatch upon said line of telegraph, until he shall first have taken an oath before some justice of the peace, that he will faithfully observe the secrecy of any dispatch so intrusted to him to forward or receive, and that said dispatch, if private, shall be communicated in the order of time in which it was received; provided, however, that in cases of important public or general news, messages for the public papers may take precedence of private messages, if, in the discretion of the operator, it is necessary.

SEC. 9. Any operator who shall be guilty of violating the provisions of the foregoing sections, shall be deemed guilty of a misdemeanor, and may be punished by fine not exceeding five hundred dollars, or imprisonment not exceeding one year, by any court in this State.

SEC. 10. This charter, and the rights under it, shall be subject to any general laws which the State may at any time make, in regard to telegraph companies.

SEC. 11. This act shall take effect from its passage.

The oath required by the charter is not a general law throughout the United States. A few of the legislatures have enacted laws similar to section 8, but practically it is a nullity, and useless.

#### BY-LAWS.

The by-laws adopted, by the shareholders at their first meeting, are in form as the following :—

1. The style and name of this company shall be the ——— Telegraph Company, under an act of incorporation, passed by the legislature of ———.

2. The annual meetings of this company shall be held in the city of ——— on the second Thursday in October in each year.

3. The officers of this company shall be a president, secretary, and eleven directors, to be elected by the stockholders, at each annual meeting.

4. The president shall be *ex-officio* a director, and preside at the meetings of the stockholders and board of directors, giving the casting vote in case of ties. He shall have power to appoint and dismiss at will all operators, clerks, inspectors, and agents, of every description, who are, or shall be employed in operating, superintending or repairing the line. He

shall see to the proper supplying of the line with all things needed for its successful operation; to manage the system of reports, tariffs, working, and all finance affairs of the offices of the line. He shall keep an account of all moneys expended by himself and agents of the line (requiring receipts in the disbursement of moneys, in every case practicable). He shall keep his accounts and books posted and properly prepared for the examination of the board of directors. He shall employ such aid and assistance as he may deem necessary in the management of the line, and to pay to such assistants, compensation commensurate with their services, according to his judgment. The president shall have power to retain in his hands a sum not exceeding five hundred dollars, to meet contingent expenses of the line; but any sum in his hands over that sum, he shall deposit in some safe banking-house, agreed to by the board of directors, for the benefit of the company, and under the control of the said board of directors.

5. The secretary shall keep a record of the proceedings of each meeting of stockholders and board of directors, and discharge such other duties as may be assigned him by the board of directors.

6. The board of directors shall meet quarterly, in the city of \_\_\_\_\_, on the first Thursdays in January, April, July, and October, and at such other times as may be called by the president, or upon petition of eight directors. They shall adopt such rules regulating their meetings as they may elect, not incompatible with the charter and laws of the company. They shall also call special meetings of the stockholders whenever emergencies may require it, or whenever stockholders owning or representing one third or more of the stock, petition for the same.

7. In case the board of directors refuse to call a special meeting of the stockholders upon petition of holders of one third or more of the stock in the line, then it shall be lawful for two or more persons holding or representing one third or more of the stock, to call such meeting, by public notice, in any one or more newspapers published in the towns through which the line passes. All notices for special meetings of the company, shall be given by public advertisement, as above stated, at least thirty days previous to the time fixed for such meeting.

8. No member of this company is, or will be held, to any individual liability beyond the amount of capital stock subscribed by him. No director, or other officer of this company, has power to contract any debt or obligation, creating a charge upon the members individually, or upon any other fund than the capital stock, property and income of the company.

9. The president shall give bond to the company for the faithful discharge of his trust, whenever the board of directors may require it, and for an amount agreed to by said board.

10. All officers, elected by the stockholders, shall hold their offices until others are elected.

11. A vacancy occurring in the board of directors, the remaining directors shall have power to fill such vacancy. If the president or secretary vacate their office, the board shall have power to elect a pro-tem officer until the company meets.

12. In all meetings of this company, the stockholders shall be entitled to one vote for each share held by them respectively. Stockholders may vote in person, or by proxy, or agent constituted for that purpose, in writing.

13. The holders of a majority of stock shall constitute a quorum to do business. Every question shall be decided by a majority of votes present.

14. The president shall receive, as a compensation for his services, fifteen hundred dollars per annum, and his travelling expenses incurred when from home, in the service of the company.

15. The board of directors shall declare a dividend upon the stock of the company, at such times as they may elect, whenever the surplus funds on hand may justify.

16. Four directors, with the president, shall constitute a quorum, for the transaction of business at all meetings of the board of directors.

In case a superintendent is authorized, his duties are confined to the management of the offices, and the keeping of the line in repair.

In some cases, the board of directors adopt a code of rules for the working of the line, prescribing the duties of the operators and employés of the company. It is usual, however, for those rules to be made by the president or superintendent, so that they can be readily altered, as circumstances may require, from time to time.

The employés of a line are the operators, cashier or manager of an office, clerks, messengers, repairers, and battery keepers. The rules adopted for the administration of the line are in the form following, viz.:

#### OFFICE REGULATIONS.

1st. Each telegraph office will be open every day, except Sunday, from sunrise to 10 P. M. The manager of each office will accordingly distribute his force so as to arrange the hours of necessary absence, in order to have at all times some competent operator in the office from sunrise to 10 P. M., nor will this regulation be construed to authorize or justify the closing of the office at that hour if there be any unfinished business. The manager will be required to keep a journal, in which all matters connected with the line, worthy of note, shall be entered daily. The office will be opened on the Sabbath at the usual hour, and close at 9½ A. M., and again opened in the afternoon at 4 o'clock, and closed at the usual hour at night.

2d. The first business in the morning is to examine the batteries, test the lines, and ascertain if the connecting lines are all in working order; the hour to be noted in the journal when each office is prepared for business. Should the line, or any part thereof, be out of order, the time, cause, or supposed cause, is to be noted in the journal, and the manager of each office is required to adopt means to have it repaired, by sending out any of the operators, clerks or other persons at his discretion. It is understood to be the duty of all operators and clerks to turn out on such occasions when required, their expenses being provided for by the company.

3d. The line of telegraph shall be open to all who shall tender and pay the regular charge which may be fixed upon for its use, and first come shall be first served, subject to the following limitation as to time: No individual, or combination of individuals, shall have the use of the telegraph more than fifteen minutes at one time when others are waiting; preference, however, may be given to the proper officers of the States or of the United States, in any great public emergency, or to police officers, to promote the arrest of fugitives from justice, and to prevent the commission or consummation of crimes.

4th. Dispatches in all cases will be regarded as strictly confidential, and they must be kept from the inspection of all persons, whether con-

ned with the line or not, and must not be the topic of comment or conversation by those whose duty it is to transmit, receive, or deliver them.

5th. Should any person employed in the offices of this company divulge or use for his own benefit, or for the benefit or information of any other person or persons whomsoever, the contents of any dispatch to which he may be privy; or should any person at stations other than the one receiving, read, use, or divulge the contents of such dispatch, said person or persons shall be considered as unworthy of trust and confidence, be forthwith dismissed from service, and not again employed on the line.

**CASHIER.**—The cashier of the office shall have absolute charge of all matters concerning all departments of business of said office.

He shall receive all dispatches to be transmitted, and the moneys for the same, keeping proper check and account thereof.

He shall see to the copying of all dispatches, and their prompt delivery.

He shall be the only authorized officer to issue orders for the purchase of material, and all bills are to be paid by him or by his order.

He shall keep an account of all expenditures under the respective heads contemplated in the monthly reports, specifying for what line moneys are used.

When the operator of any line reports that the same is out of order, he shall provide all the means and necessary material to effect its immediate repair.

He shall be the sole manager of the book-keeping, registration, and preservation of all books and papers of the office, belonging to the united lines therein terminating.

He shall make out the regular weekly, monthly, or other reports of his office, according to the forms adopted or authorized by each line respectively.

He shall deposit with the company's bankers all moneys accruing in his office, whenever the sum exceeds twenty-five dollars.

In case an operator is sick, or otherwise hindered from keeping his business up square, according to rule, he shall provide all necessary aid to effect the same.

He shall employ all clerks, battery-keepers, and messengers required in the office, and to dismiss the same at his pleasure.

He shall make payments to operators according to their respective salaries, in such manner as may be directed by the law of the line.

**OPERATORS.**—The operator of each line shall have sole charge of his register, magnet, and other connections of line in his office.

He shall send and receive all messages transmitted over his line.

He shall be the inspector and repairer of his section of line, and has power to employ all aid necessary to secure its speedy repair, when "out of order."

In case any new material is needed to secure the better working of the line, he shall report the same to the cashier, who will provide it without delay.

**CLERKS.**—Clerks employed in the office shall assist in receiving dispatches, and see to the proper spelling and address of all names for whom messages are received.

Each shall hold himself in readiness to assist in the performance of any duty in the office or on the line, as may be judged by the cashier.

**BATTERY-KEEPER.**—The battery-keeper shall have charge of the battery of each line, and see to its construction, according to the adopted system, and have it in readiness at the required working hour in the morning.

**MESSENGERS.**—The messengers employed shall promptly deliver all messages intrusted to them, without partiality as to line or person.

They shall keep in order the entire office, and have it in proper condition by the business hour of each morning—see to the fires and security of material belonging to the office under their charge.

They shall be responsible for all collections intrusted to them, or the return of the dispatch upon which payment may be refused.

They shall perform such other duties as may be required, from time to time, by the cashier.

#### RULES FOR SENDING AND RECEIVING MESSAGES.

1st. All communications must be carefully read, for the purpose of seeing that every word is plainly and fully written out, with the address, number of house or place, and name of town and street to which the message is directed, and if the receiving clerk doubts the meaning of any portion of the message, he will at once refer to the author for explanation.

2d. He will then count and write the number of words on the message, and the amount received for its transmission, then number the message, beginning each morning with No. 1, and entering the number, date, time, name of person sending, to whom and where sent, number of words, amount charged, and money received and paid for other lines; any remarks deemed necessary will be made on the book, and the message filed to be transmitted in its regular turn.

3d. No operator must attempt to write under any circumstances, while another is writing on the same circuit or wire; he must wait for the finish signal; as disregard of this rule will produce confusion and delay.

4th. If a communication cannot be sent in reasonable time, or being sent, does not reach its destination through the fault or delay of the telegraph, the money received will be refunded, and a receipt taken therefor; but in all such cases it must be proved beyond a doubt that the fault is with the telegraph.

5th. The originals of all messages transmitted must be neatly bundled up each day, and, the date being written upon the envelope, deposited in a box provided for that purpose, as it may be necessary to refer to them.

6th. The arrival of every steamer from Europe shall be telegraphed gratis to every station on the line, to be posted on a bulletin for the information of the public; precedence will be given to this information in all cases; but no precedence will be given to the steamer's news.

7th. When a communication is received by telegraph, it will be immediately copied and plainly written out, and the number of the message, date, time, name of person sending, to whom sent, number of words, the amount charged, and name of operator and carrier, entered in a book provided for the purpose.

8th. The message will then be enclosed, sealed, directed, and placed in the hands of a carrier to be delivered; and in case any person to whom a message is directed cannot be found, the carrier will return it to the station for the clerk to endorse thereon the date and name of the carrier. The message will then be carefully filed for future reference.

Messages offered at the counter of the telegraph company for transmission are not required to be written on the forms adopted by the company. Many of the companies have no forms, using plain paper. Messages can only be transmitted in the English language, and they may be written with ink or pencil, on any kind of paper, without regard to size. I have

seen persons on steamers running on the western rivers, write their dispatches on a piece of board, about a foot long, and as the steamer would near the shore in the locality of an office, the board would be thrown ashore. The dispatch thus written would be sent by the telegraph. Merchants, generally, write their dispatches and copy them in a tissue leaf book, by transfer in a screw press. When copied, the original is sent, by a porter, to the telegraph office. The money is sent with the dispatch, but it is not compulsory. Many dispatches are sent with the charges to be collected at the destination. Pre-payment for answers is never required, and original dispatches, offered by persons known, can be pre-paid or not, at the option of the sender. The rule, however, contemplates pre-payment. The words "answer by telegraph," and "answer paid here," are sent free. Besides these words, when requested by the sender, the words "messenger get answer," are added and sent free. Dispatches received over the line by a station to be collected, are given to the messenger, and on their delivery the charges are demanded.

As in Europe, many of the American lines provide each messenger with a book, in which are entered the name of each person whom the dispatches are for, and on delivery, the person receiving the message writes his name and the time of reception in the book. This formality is regarded as a receipt to the messenger and the company. If there is any money to be collected on the dispatch, the sum is set down in the book opposite the name, and it is also written on the corner of the face of the envelope. On the messenger's return to the office, he pays over the money collected. The formality of the book is not in universal use. Many offices being provided with a full corps of messengers, deliver a dispatch the moment that it is received, without the delay of entering in a book, or an accumulation of messages for the same route; that is to say, when a message is received, it is sent for delivery immediately. This celerity in delivery, at many stations, requires a large number of messengers.

Night service is seldom required. The agent for the press can order the lines opened all night, by paying a contracted sum for the extra service. There is no general rule allowing the public to command the lines to be kept open at night, beyond the hours prescribed in the rules. Nevertheless, if business is offered all night, the lines are kept open all night, without any compensation, more than the daily charges. I have never known a case where a private individual desired to command the line to be kept open beyond the regular hours.

When lines have been down, perhaps for the day, a large amount of business accumulates, often requiring the whole night for its transmission. This has been under ordinary circumstances. The rule, therefore, may be thus stated, "The line is never to be closed, day or night, as long as there is a single dispatch to be sent," and that no extra charges are to be made for the night, except in the case cited, as arranged by contract.

#### BRITISH PROVINCES IN AMERICA.

The construction of telegraph lines in the Canadas, New-Brunswick, Nova-Scotia, and Newfoundland, has been under the direction of organized companies. It has been usual to obtain a charter from the provincial parliament, incorporating certain persons therein named as a company, having in view the construction and maintenance of a telegraph line or lines on certain specified routes or territory. After the charter is granted, books are opened for subscriptions for shares, upon which a small per-centage is paid. The necessary capital having been subscribed, and the per-centage paid, a meeting of the shareholders is held, at which by-laws are made, permanent officers elected, and all the necessary preliminaries for the consummation of the enterprise are arranged. Proposals are received from different persons for the building of the line, in whole or in part, which are accepted or declined, as circumstances dictate. Sometimes, the line is built by the company, having no contractors. The foregoing formality constitutes the whole procedure for the organization of companies, and the construction of lines in the provinces.

In the Canadas, no monopoly in telegraphing has been accorded to any one. The territory is open to any person or company to build lines. In New-Brunswick, Nova-Scotia, and Newfoundland, exclusive monopolies have been granted by the provincial parliaments to separate companies in each. In Newfoundland, the monopoly has been given to the New-York, Newfoundland, and London Telegraph Company, for the term of fifty years, from March, 1854. The Nova-Scotia Company holds the exclusive monopoly in that province. In the United States, the monopoly runs with the duration of the patents. A patent runs for fourteen years, and may be renewed for seven more by the commissioner of patents. After the renewed term, Congress can extend the patent consecutively for seven years thereafter. This latter case is rarely granted. This subject is referred to here, to show the relative monopolies

enjoyed by the lines in the United States, and by those in the provinces. In the former, however, no legislative laws can accord to a company exclusive monopoly, and the patented term limits the question; but in the latter, no patent privileges have been held by Morse, and the monopoly runs with the legislative enactment. From these facts, it will be seen—

1st. That in the United States, the monopoly in telegraphing runs with the term of the patent, the right of which has to be purchased by the given company.

2d. In the Canadas, there are no legislative monopolies sanctioned by the parliament, and there are no patents—the inventions being free to all persons.

3d. In Nova-Scotia, New-Brunswick, and Newfoundland, the inventions are free, but the monopolies enjoyed by legislative enactments of the provincial parliaments, are more than equivalents for patents.



## CHAPTER LV.

Tariff on Dispatches in America—Words Chargeable and Free—Arrangement of Local Tariffs—Qualifications of Employés—Protection of the Telegraph—Secrecy of Dispatches—Penalty for Refusing to Transmit Dispatches—Patent Franchise Inviolable—The Right of Way for Telegraphs.

### TARIFF ON TELEGRAPHIC DISPATCHES.

THE tariff of charges on dispatches transmitted on the telegraph lines in the United States and the British provinces, is not determined by length of line, but by the expense of things in life. Thus, in the Eastern States, a man can live much cheaper than he can in the Southern States. Each company adopts its own tariff. Sometimes the local charges are higher than the through charges; such as on messages coming from other lines and destined for other lines beyond. In the former charges, the expense of copying, stationery, messenger, and registration, are items to be considered. The latter, or through messages, coming from and going over other lines, only require the registration of number and amount. But few lines in America can pay any interest on its capital, out of its revenue from local business. Owing to this well-established fact, every company aims for through business, and in the past, much rivalry has been exhibited by different companies for the business of their respective ranges or sections of country. The lines as to ranges extend northeastward from New-York to Halifax, Nova-Scotia. Another range extends from New-York, northward to Montreal and Quebec, in Canada; another, northwestward along the great Lakes, to Cleveland, Chicago, and Milwaukie; another from New-York, westward to Pittsburg, Cincinnati, St. Louis, and Leavenworth city; another from New-York to Washington, Charleston, Mobile to New-Orleans; and another from New-Orleans, northwestward, along the Mississippi Valley to St. Louis and northward. The tariffs on these respective ranges differ. The rates in the East are the least, and in the South, the highest. This difference is caused, as I have said before, by the general expense of living. In the East, a good operator can be employed at from six hundred to a thousand dollars per annum. In the South, it is from one thousand to fifteen hundred dollars per annum. Board ranges in the East, at about three dollars per week; in the South, the same board would be seven dollars per week. The cost of labor is in like proportion. The same may be said of

all kinds of materials needed in the affairs of life. With a view of further explaining this difference in the tariffs, I will give the charges on parts of the respective sections. From New-York to Boston the distance is about 250 miles, and the tariff on a message of ten words is forty cents, and for each additional word over ten, three cents. From New-York to Washington, about 250 miles, on a message of ten words, the tariff is fifty cents, and five cents for each additional word. From New-York to Pittsburg, about 350 miles, on a message of ten words, seventy-five cents, and six cents for each additional word. From New-Orleans to Savannah, Georgia, about 800 miles, on a message of ten words, \$1 40, and seven cents for each additional word. From New-Orleans to Jackson, Mississippi, about 200 miles, on a message of ten words, seventy-five cents, and five cents for each additional word. From St. Louis to Leavenworth city, Kansas, about 360 miles, on a message of ten words, sixty cents, and five cents for each additional word. From New-Orleans to Louisville, about 950 miles, the tariff is \$1 40, for a dispatch, and eight cents for each additional word. From Louisville, east to New-York, about 850 miles, the tariff is \$1 for a single dispatch, and six cents for each additional word over ten. Side or lateral lines connecting with these leading ranges, have tariffs upon the same scale. Each company gets whatever tariff it charges, except in some cases the rates are reduced to get business from other routes. As a general thing, the tariffs, throughout the whole country, have been increased within the past year, and lines, companies, and ranges, have been consolidating their interest and making each more effective for public accommodation.

The tariff on news for the press, is a fraction less than for ordinary messages. The newspapers have formed an association with a general agent in New-York, who has power to appoint all sub-agents throughout the country. This general agent manages the entire telegraph news department for the Associated Press. In the transmission of news by the telegraph, a cipher is used, and by special contracts made with the respective ranges of lines, the news is a very heavy expense to the American press. In former years the telegraph lines made a deduction of fifty per cent. on the press news, but at the present time the companies charge about the same for news sent to or from the news agents as the charge for like service to others. The lines and the agents generally assist each other, and reciprocity in service redounds to the welfare of the newspapers and the public, whose weal the

ambition of all strives to promote, that ulterior good may be shared by the meritorious.

## WORDS CHARGEABLE AND FREE.

A message throughout the United States and British provinces is scaled to ten words, beyond which the price for each word is generally about twenty per cent. less. On the line from Savannah to New-Orleans it is fifty per cent. less for each added word ; from Boston to New-York, twenty-five per cent. less ; and from St. Louis, westward, sixteen per cent. less. — The average may be considered at twenty per cent. discount on all words over the first ten. No charge is made for signature or address. Thus, a message may be transmitted :

TREMONT HOUSE, *Boston, Massachusetts, January 1st, 1859.*  
 To JOHN JAMES DOE, Esq., *No. 500 William-street, third story, room No. 25, New-York City.*

Purchase for me one thousand barrels of flour, and ship to me at New-Orleans, immediately. 44. 33.

WILLIAM RICHARD ROE.

The above is the form of a message usual on the American lines. There are fifteen words. According to the tariff herein before given, for the first ten words the charge is 40 cents, and the 5 added words three cents each, or 15 cents—total, 55 cents. The figures 44 means "Answer immediately by telegraph," and the figures 33 means "Answer paid here." These figures, as stated herein before, are free. The word New-Orleans, being the name of place, is counted as a compound word. The address and signature make 36 words, all of which are transmitted free. Each figure is counted as a word. The telegraph companies in the United States and the British provinces solicit particulars as to address, and the policy is good. In Europe many men locate and remain a lifetime in the same building and in the same business. Like cases rarely occur in America. In the former country, a brief address is sufficient, but in the latter, particulars are necessary. Experience has taught that it is best for the telegraph to encourage its patrons to be full in address. In the form given, fifty-one words are transmitted in one dispatch for 55 cents. There is no charge for delivery. (The telegraph encourages explicitness in the writing of a message, and discourages the use of ciphers formed by letters or figures. And for the purpose of discouraging laconic dispatches, the companies have adopted the liberal discount in the tariff on all words over ten in a message. It encourages the patrons to write their dispatches full and intelligible.

## ARRANGEMENT OF LOCAL TARIFFS.

Each telegraph company arranges its tariff of charges, and supplies its offices with printed schedules, which are also transmitted to all other companies. The tariff is prepared in the following form, viz. :

|                   | New-York. | Philadelphia. | Baltimore. | Washington. |
|-------------------|-----------|---------------|------------|-------------|
| New-York.....     |           | 25.2          | 40.3       | 50.5        |
| Philadelphia..... | 25.2      |               | 25.2       | 40.3        |
| Baltimore.....    | 40.3      | 25.2          |            | 25.2        |
| Washington.....   | 50.5      | 40.3          | 25.2       |             |

Each station has a tariff thus arranged to all other offices on its line, and when messages are received for stations on other lines, by adding the two tariffs, the whole is known. Suppose a message is offered at Baltimore for Boston. The tariffs from Baltimore to New-York, and thence over another line to Boston, are added together, and the charge, 80 cents, and 6 cents for each additional word, is the price of the message. Baltimore receives the 80 cents and transmits the dispatch to New-York, where it is written out in full, and it is then, with the 40 cents, delivered to the New-York and Boston line. Lines occupying the same building have facilities in matters of accounts and the transfer of messages from line to line. In former years, when rivalry was at its highest, the companies would deliver the message and the money to the next in course, in the same manner as the public. No accommodation, no favor of any kind, nor any association between the agents of the companies, was entertained. Feuds between rival companies, however, are fast passing away, and it is to be hoped that ere long the misfortune will cease to exist forever.

The tariff of charges on messages in the Canadas, Nova-Scotia, Newfoundland and New-Brunswick, are established in the same manner as upon the lines in the United States. In the provinces, where a monopoly has been enjoyed, a higher and more remunerative tariff has been charged from the first organization of the lines.

## QUALIFICATIONS OF EMPLOYES.

There have been no fixed rules determining the qualifications of persons proposing for employment on the telegraph lines in

America. Each company exercises its own judgment in the engagement of its agents, and the general rule has been, to select the person most fitted for the place in view. Thus, in employing an operator for a small local station, doing but little business, an expert in manipulation has not been considered as necessary. In localities where the line may need much repairing, a man best fitted for such service is selected. At stations where great expertness is necessary for celerity of business, superiority of manipulation is regarded as of the greatest importance. With the explanations just given, it will be seen that the qualifications required on the American lines are but ordinary, and may be considered as follows, namely: a moderate English education, that is, to read, write, and cipher; and to spell well, is the most important. While the reader may consider the education demanded by the lines in Europe, as too great for the requirements of the service, it must be admitted that a superior education can not be regarded as an injury and if a sufficient corps, at moderate expense, can be employed, the system will be operated nearer to a state of perfection. Difficulties experienced on many lines in America, originating from the ignorance of operators, cannot take place where the education is as required on the French lines. It is to be admitted at once, that on the American lines the French rules could not possibly be enforced, for the reasons, that the compensation given will not command the talent, and the revenues are not sufficient to justify such an enormous expenditure as would be necessary for the engagement of the highest order of talent. Besides the question of economy, many may doubt the actual necessity of requiring more than a sufficient education for the positions occupied; that is to say, by way of illustration, a blacksmith would be benefited by a thorough knowledge of chemistry, so that he could fathom the mysterious agencies in nature, concerning metals; yet this knowledge is not indispensable, nor even necessary, to teach him how to shoe a horse.

The organization of society in Europe requires, in most of pursuits, *forms*, and within its rules is embraced the qualification of candidates for service on the telegraph. In America, there are no such necessities existing. Labor, in whatever branch, cannot be superior to that of another. This equalization is a fundamental and cardinal virtue in American institutions. The society of the respective continents, therefore, has different elements of existence.

Without boasting, and without the possibility of practical contradiction, I can state that, as an average, the American ope-

rator has no superior, and he can receive and transmit a greater number of dispatches than I have ever seen attained, or claimed, by the operators of other countries. This subject, however, will be discussed in another part of this work.

The qualifications, therefore, demanded of a candidate for employment on the American lines, are but few, and very simple, viz., a moderate English education, honesty, energy of character, and a few months' practical service as a manipulator.

PROTECTION OF THE TELEGRAPH.

In most of the American states, penal laws have been adopted, from time to time, for the protection of telegraph lines. At the opening of the courts, the judge embraces the question in the charge to the grand jury, requiring that body to indict every person who may be guilty of a violation of the law. For the honor of the people, however, but few cases have occurred requiring the exercise of the duty. In the early history of telegraphing, the most formidable objection to overground lines, was the liability of interruption by malicious and mischievous persons, in the breaking of the lines, &c. Experience has proven that the people do more to maintain the lines in order than to disturb them. The penal laws adopted are more or less severe, and it cannot be doubted, but what they have had a salutary influence. The laws are of the following form and tenor, viz. :

“ Any person or persons, who shall intentionally and unlawfully injure, molest, or destroy, any of the lines, wires, posts, instruments, abutments, or any of the materials or property of any telegraph company, association, or owner, or shall by any means whatever, interrupt the working of any line of telegraph in the transmission of despatches or otherwise, shall, on conviction thereof, be deemed guilty of a misdemeanor, and be punished by fine not less than \$500, nor more than \$1,000, or imprisonment in the penitentiary for a term not less than one year, nor more than three years, or both, at the discretion of the court having cognizance thereof.”

SECRECY OF DISPATCHES.

Penal laws have been very generally adopted, to secure the secrecy of messages transmitted over telegraph lines. The ordinary rules of the companies upon this subject, have been sufficient, however, in a general sense, to protect the public in this respect. The following is an extract from one of the penal statutes, viz. :

“ Any person connected with any telegraph company in this state, either as clerk, operator, messenger, or in any other capacity, who shall

willfully divulge the contents, or the nature of the contents, of any private communication intrusted to him for transmission or delivery to any person, other than the one to whom it is addressed, or to his agent or attorney, or who shall refuse or neglect to transmit or deliver the same, shall, on conviction before any court, be adjudged guilty of a misdemeanor, and shall suffer imprisonment in the county jail in the county where such conviction shall be had, for a term of not more than three months, or shall pay a fine not to exceed five hundred dollars, in the discretion of the court.

PENALTY FOR REFUSING TO TRANSMIT DISPATCHES.

In most of the States, penal laws have been enacted, relative to the transmission and reception of dispatches, by the telegraph companies. Any dispatch, with the money for its transmission, offered at a station, cannot be refused by the telegraph company, except in cases where the transmission would be in violation of the patent rights of another company. No one can be excluded from sending messages over any line and by any route, that he wishes, except in the case above cited. From one of these acts I extract the following, viz. :

"Every such company, and every owner or association, engaged in telegraphing for the public by electricity, in this State, shall receive dispatches from and for other telegraph lines, companies and associations, and from and for any individual; and on payment of the usual charges for transmitting dispatches, according to the regulations of such company, owner or association, shall transmit the same faithfully and impartially, and in the order in which they are received; and for every willful neglect or refusal so to do, the company, owner or association, as the case may be, shall be liable to a penalty of not more than one hundred dollars, with costs of suit, to be recovered in the name and for the benefit of the person or persons, association or company, sending or desiring to send such dispatches."

Such enactments as the above, originated some years ago, when one of the leading companies refused to receive dispatches from or for lines holding rival positions. The rejecting of these dispatches caused those in rival interest to memorialize the respective legislatures for the passage of laws of the nature as above given. The legislatures promptly passed the necessary laws, though for a combination of reasons they have not been practically effective, owing to the patent laws of the land, limiting their enforcement. Upon the expiration of the patent franchises held by the companies, then the special law with its penalty can be enforced. The common law will guarantee the right to any one to command the transmission of his dispatch, equally with all others, on its presentation with the money at any telegraph station.

PATENT FRANCHISE INVIOABLE.

I will further explain the exception mentioned, relative to patent franchise, before referred to. Suppose A purchases the patent monopoly to transmit all messages between the cities B and C. The United States patent laws will protect A in the enjoyment of that franchise. It is the property of A, and he has the right to use it or not, in such manner as he pleases. Suppose D constructs another line, either by a more circuitous or direct route between the cities B and C, dispatches cannot be sent over the line of D, originating from either of the cities cited to the other, in violation of the rights purchased by A. If the law was otherwise, a patent would be worthless, and an inventor could not hope for any compensation for the toil and time devoted toward the achievement of his invention, however grand in its consummation. Having due regard for the exception given, no company can refuse to transmit a message offered, and in such manner as directed by the sender. For example, suppose a merchant in New-Orleans presents a dispatch and the money for its transmission to any telegraph line, directed to a merchant in London, to be mailed in New-York, or to be sent by the Azore Atlantic telegraph route, or by the Newfoundland and Ireland Atlantic telegraph route, or by the Greenland and Iceland Atlantic telegraph route, the telegraph company cannot refuse to receive the message and send it in the manner specified upon the face of the dispatch. Even at the present time, during the existence of the patent franchises, the dispatch offered in New-Orleans in the example given, could not be refused. In some cases companies form an association to give each other business originating on the one, for places on the other, but no such compact can take from a member of the public the right to transmit his dispatch by any given route he may wish. In further illustration of this common and statute law, I give the following diagram :

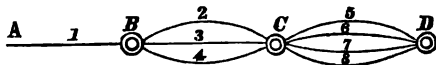

Letter A is New-Orleans. B, Cincinnati. C, New-York. D, London. Figure 1 represents the telegraph line from A to B. Fig. 2, the telegraph line, via Buffalo to New-York. Fig. 3, the line via Pittsburg to New-York., Fig. 4, the line, via Baltimore to New-York. Fig. 5, the Greenland and Iceland Atlantic telegraph route. Fig. 6, the Newfoundland and Ireland Atlantic telegraph route. Fig. 7, the direct Atlantic



telegraph route; and fig. 8 the Azore Atlantic telegraph route. The merchant in New-Orleans can present his dispatch to be sent to B, and thence by line 2, 3, or 4, as he may prefer, to New-York, and thence by either 5, 6, 7, or 8, to London. Neither the company receiving the message at New-Orleans, nor any intermediate company, can change the route from the one directed by the sender.

I have written that the public has the right to transmit messages by such route or routes as it prefers; *provided*, the lines proposed to be employed in the transmission of the message, by such an act, do not violate the purchased rights of others. In the diagram above given, if line 3, or either of the others, has purchased the *exclusive right* to transmit messages between B and C, originating at those places and along that route, and also all messages from points beyond B and C respectively, destined to B and C and points beyond respectively, then lines 2 and 4 would violate the rights of line 3 by the transmission of business originating as specified, and the line cannot be compelled to thus involve itself. If, however, line 3 has only purchased *the right* to send dispatches, and has not the *exclusive right*, there will be no violation of the patent franchise of 3 by the sending of messages over the lines 2 and 4, which have also *the right* by purchase, to transmit dispatches between B and C in common with other lines.

In case the route is not specified by the sender, the company can transmit the message by such lines as may be in its particular combination. As a general rule, it may be admitted, that every company will be glad to send the message by the route that can do the business the most prompt, and all combinations fettering the efficient line with the inefficient, will fail in execution, and sooner or later cease to exist. The interest of the line is the better subserved by the greatest promptness in the dispatch of business. By these remarks, it will be seen that the common and statute laws, the interest of the telegraph, and the rights of the public, harmonize one with the other, each aiming for "the greatest good to the greatest number."

#### THE RIGHT OF WAY FOR TELEGRAPHS.

In nearly all the States laws have been passed, giving the free right of way to any and all telegraph companies, to build lines over the public lands and highways. The following is an extract from one of these statutes :

"Any telegraph company may construct lines of electric telegraphs upon and along any of the highways and public roads, and across any of

the waters within the limits of this State, by the erection of necessary fixtures, including posts, piers, or abutments, for sustaining the wires of such lines; *provided*, the same shall be so constructed as not to incommode the public use of said highways or roads.

"If any person over whose lands any telegraph line shall pass, upon which said posts, piers, or abutments, shall be placed, shall consider himself aggrieved or damaged thereby, it shall be the duty of the county court, within whose county such lands are, on the application of such persons, and on notice to the association or individual owning such telegraph line, to appoint three discreet and disinterested persons as appraisers, who shall severally take an oath, before any person authorized to administer oaths, faithfully and impartially to perform the duties required of them by this act. And it shall be the duty of said appraisers, or a majority of them, to make a just and equitable appraisal of all the loss or damage sustained by said applicant, by reason of said lines, posts, piers or abutments, duplicates of which said appraisal shall be reduced to writing, and signed by said appraisers, or a majority of them; one copy shall be delivered to the applicant, and the other to the president or other officers of said association, or corporation, or owner of such telegraph on demand; and in case any damages shall be adjudged to said applicant, the association, or corporation, or telegraph owner, shall pay the amount thereof, with costs of said appraisal; said costs to be liquidated and ascertained in said award; and said appraisers shall receive for their services two dollars for each day they are actually engaged in making said appraisal."

# ORGANIZATION AND ADMINISTRATION OF EUROPEAN TELEGRAPHS.

---

## CHAPTER LVI.

The Telegraph in France—Decrees permitting the Public to Telegraph—Regulations on receiving and transmitting Dispatches—Conditions of Admission of Supernumeraries—Programme of Preparatory Education required of Candidates.

### THE TELEGRAPH IN FRANCE.

THE French government was about the first on the continent to adopt the semaphore telegraph, the invention of the Brothers Chappe. For many years the efficiency of this means of communication was experienced. As soon as the electric telegraph became a demonstrated and practical system, France was foremost in Europe to avail itself of its wonderful means of transmitting intelligence.

The permanent secretary of the Academy of Sciences, M. Arago, did much to procure its early adoption by the government. In 1838, Louis Phillipe, the king of the French, prohibited Prof. Morse from constructing a line of his telegraph, but, in a few years after, the advantages of the electric system over the semaphore were acknowledged, and lines were soon spread throughout the kingdom, built and managed by the government. I deem it unnecessary to follow the progress of the lines in their construction, and I shall, therefore, consider the system in that country as it is at the present time.

### DECREES PERMITTING THE PUBLIC TO TELEGRAPH.

The imperial government of France has, from time to time, issued decrees regulating the use of telegraphing in the empire. The following is a digest of some not embraced in the rules issued by the Minister, concerning the operation of the lines :

1st. All persons whose identity is established, are allowed to correspond by the government electric telegraph, by the agency of functionaries employed in that department.

2d. Private correspondence is always subordinate to the necessity of government service.

3d. Dispatches are to be written in *ordinary and intelligible language*, dated and signed by the sender, and to be given to the officer of the telegraph station, whose duty is to copy in full the dispatch, with the address of the sender. This copy is to be authenticated and filed in the office. Articles for newspapers and dispatches on railway business are to be exempt from the copying rule.

4th. The director of a station may, on grounds of public order and morality, refuse to transmit a dispatch. In case of dispute, reference is to be made in Paris to the minister of the interior; in the provinces, to the prefect, sub-prefect, or other constituted authority. On the receipt of a dispatch, the director of the station may withhold its delivery for like reasons.

5th. Private correspondence may be suspended at any time by the government. The government will not assume any responsibility for errors in the transmission of dispatches.

6th. Any public functionary violating the secrecy of correspondence is liable to the penalties prescribed in Art. 187 of the Penal Code, viz.: imprisonment from three months to five years, fine 100 to 500 francs, and total exclusion from public service.

7th. Dispatches affecting the safety of passengers on railway trains, in all cases, take precedence of every other business.

8th. The director of the station must be satisfied as to the identity of the sender's signature. Identity may be proved by witnesses, passports, or other written evidence. The signature may be proved by prefects, sub-prefects, magistrates, notaries, mayors, commissioners of police, &c., &c. If the director sees reason to refuse the transmission of a message, he must state his reason in writing on the dispatch, and return it to the sender. [He may endorse on it, "political," "offensive," "not consistent with public good," &c.]

9th. No line of electric telegraph can be established or employed for the transmission of correspondence except by the government, or on its authority. Any person transmitting, without authority, signals from one place to another, whether by electric telegraph, or in any other way, is liable to imprisonment from one month to a year, and a fine of 1,000 to 10,000 francs, and the government may order the destruction of the apparatus and telegraph employed.

10th. Any one *accidentally* and *involuntarily* interrupting the correspondence of the electric telegraph, or injuring in any way the lines or apparatus, is liable to a fine of from 16 to 300 francs.

11th. Any one willfully causing an interruption by injuring the lines or apparatus, is punishable by imprisonment from three months to two years, and a fine of 100 to 1,000 francs. Any one who shall make a forcible intrusion into an office, or shall use violence or menaces to signalers, or interfere with the repairs of the line, during periods of insurrectionary movements, is subject to a fine of 1,000 to 5,000 francs.

12th. Written statements by telegraph officers, authenticated by police or magisterial authorities, to be received as evidence in all complaints; also rules are given for civil proceedings in all cases of crimes, contraventions and recovery of damages.

13th. It is ordered, by a subsequent decree, that all telegraphic dispatches, duly authenticated, are to be regarded as official and authoritative, and to have all the force and effect of public documents, signed by the functionaries at the distant station from whom the telegraph dispatch proceeds.

The telegraph lines in France are nearly all owned and managed by the government. The English Submarine Company, however, is a private enterprise, and works from Paris, through Calais, to the United Kingdoms. There is also another company organized under permission of the imperial government, for the extension of the lines into the French colonies of Africa. This association is called the Mediterranean Electric Telegraph Company, and it has constructed its line from Spezia, in Sardinia, across Corsica, Sardinia, and the Mediterranean Sea, to Bône, in Africa; the governments of France and Sardinia guaranteeing a fixed percentage on a given amount of its capital stock. The lines just mentioned have a separate office in the city of Paris, and receive and send their own dispatches. Messages for these lines, however, can be left at the government stations.

The following rules of regulation are for the government of the respective lines worked by the French government:

#### REGULATIONS ON RECEIVING AND TRANSMITTING DISPATCHES.

1. Every message received at an office is to be numbered in the order of its reception, commencing January 1st, and continuing thereafter in regular order through the year.

2. The number of the message, and the sum received, are to be transcribed on a check-book containing the following forms:

| No. 4625.           | A.<br>August 11, 1858.                                                                                                                                                  | B.<br>No. 4625.<br>August 11, 1858.                                                                                                                             |
|---------------------|-------------------------------------------------------------------------------------------------------------------------------------------------------------------------|-----------------------------------------------------------------------------------------------------------------------------------------------------------------|
|                     | Paid the sum of eight francs and seventy centimes, for the transmission of a telegraphic dispatch from Paris to Marseilles. Distance, 67 myriameters. No. of words, 15. | Received of Mr. Bernard nine francs and twenty centimes, for a dispatch addressed to Mr. Lefever, at Marseilles. Distance, 67 myriameters. Number of words, 15. |
| h. m.               |                                                                                                                                                                         | f. c.                                                                                                                                                           |
| Deposited . . . . . |                                                                                                                                                                         | Charge { French lines . . . . .                                                                                                                                 |
| Sent . . . . .      |                                                                                                                                                                         | { Foreign lines . . . . .                                                                                                                                       |
| Received . . . . .  |                                                                                                                                                                         | Messenger . . . . .                                                                                                                                             |
| Delivery . . . . .  |                                                                                                                                                                         | Express . . . . .                                                                                                                                               |
|                     |                                                                                                                                                                         | Extra express . . . . .                                                                                                                                         |
|                     |                                                                                                                                                                         | f. 9 20                                                                                                                                                         |
|                     | (Signed.)                                                                                                                                                               | Charge { French lines 8 70                                                                                                                                      |
|                     |                                                                                                                                                                         | { Foreign lines . . . . .                                                                                                                                       |
|                     |                                                                                                                                                                         | Messenger . . . . .                                                                                                                                             |
|                     |                                                                                                                                                                         | Express . . . . .                                                                                                                                               |
|                     |                                                                                                                                                                         | Extra express . . . . .                                                                                                                                         |
|                     | BERNARD.                                                                                                                                                                | f. 9 20                                                                                                                                                         |

On the back of the receipt B, held by the sender, is written the following as an instruction, viz.:

"No reimbursement can be made, except on the return of this paper, receipted. The demands for reimbursements must designate the number of the register."

3. The register and cash-book are arranged to serve as day-books, and every day, after business hours, the moneys received must be added up, and the reimbursements must be then deducted.

4. The expenses incurred for travel, postage, and all other payments, are to be advanced by the station-master, and not to be taken from the money-drawer.

5. A list of all the dispatches sent or received, and all moneys received therefor, must be transmitted every succeeding day to the administration of telegraphs, for registration.

6. On the first of every month, or when the receipts amount to one thousand francs, payments are to be made to the finance receiver of the government, at which time a full settlement is made.

7. At the end of each month, the director of the station must submit a report of his receipts, and the sums refunded, also the expenses incurred for travel, express, postage, &c. All reports are to be made to the central administration, to be audited, after which settlements are made by the inspectors of the line.

8. Reimbursements of charges on dispatches, in consequence of delays or errors in transmission, cannot be made except by the administration.

9. The directors of the stations may reimburse on answers to messages paid in advance.

10. When a dispatch is withdrawn by the forwarder, before or during its transmission, the expense of delivery only can be refunded.

11. In all cases, no reimbursement can be made except on the return of the check receipt (B), signed by the sender. The check is then to be pasted in the place from which it was originally taken.

12. The financial affairs of the telegraph offices are under the control of the inspectors of the finances of the line. The directors of the stations must keep their books, conformably to the rules governing accountants.

13. The administration of the telegraph is alone responsible for the secrecy of dispatches.

14. The charge for a single dispatch, not exceeding fifteen words, from one part of France to another, is 2 francs and plus 10 centimes for each myriameter of distance to be sent.

15. The charge on messages from one part of the city of Paris to an-

other, or on local lines in other cities, is one franc. From and to places not over twenty kilometers from Paris, one franc and fifty centimes.

16. The charge for each additional series of five words, or a fraction thereof, over the fifteen words, is to be charged at an increase of ten per cent.

17. No charge for delivery of dispatches.

18. Every fraction of a myriameter is counted as a whole. The distance is taken on an air line on the map.

19. The following are the rules for counting words, viz. : 1st. Compound nouns, formed of separate words in the dictionary of the French Academy, such as chief-director, station-master, &c. 2d. Geographical and family names formed of several words, not including in the latter title and Christian names. Each word or name in a business firm is chargeable. 3d. Name of a street is charged as one word, the locality described is one word. This rule applies only in the address. Numbers written in full, count as many words as are used to express them. In counting figures five make a word, and the fraction additional counts as a full word. A comma or a bar of division counts as a figure, thus 327,50 count as two words,  $3,2\frac{1}{2}$  two words, the  $\frac{1}{2}$  being counted as three and the comma as one figure; 4,32 $\frac{1}{2}$  count as two words; and 33:50, are counted as six figures or two words, there being four figures and two points additional.

20. Points of punctuation in the common language and orthography are not chargeable. Parenthesis, italization, and quotation-marks, are counted two words for each. Letters separated or in groups are regarded each as a word. All signs and marks are counted as many words as are required to express them respectively; thus, A in a dia-



mond, counts as four words.

21. Messages for several stations are to be charged as follows: If the dispatch is to be sent from station A to B and C, the tariff charged at A will be for the transmission from A to B, and then the tariff from B to C is to be charged on the message to be dropped at C, and in like manner to any number of stations desired.

22. When a dispatch is addressed to several persons in the same town the charge for transmission is to be on one dispatch only, but on every duplicate delivered to other persons, the cost of delivery will be charged, and for the copying a charge of fifty centimes will be required for each.

23. Any one wishing a copy of a dispatch either sent or received by the person, a charge of fifty centimes will be required for copying it, and for which a receipt will be given by the officer of the station.

24. Any one wishing information of the time of the delivery of a dispatch transmitted by such person, or the time of its reception at the destination office, a charge will be made, equal to one fourth the price of a dispatch to said place. For this payment a receipt will be given.

25. For having a message repeated back to the sender, full tariff will be charged, as though it was a new dispatch.

26. The charge on dispatches sent in the night will be double the usual tariff for the day business. The night hours are from 9 P. M. to 8 A. M., during the winter months, and from 9 P. M. to 7 A. M., during the remainder of the year.

27. Answers paid for in advance, are to be charged at the rate of a single dispatch, but if the answer should exceed the payment made, it cannot be delivered until fully paid. If no answer be sent, the money will be returned.

28. When any one to whom a message is sent does not live in the locality of the destination office, the sender must indicate the mode of its delivery, for which the following charges shall be made, viz. : For delivery at post-office half franc, plus forty centimes for postal registration; for

sending by express, one franc for the first kilometer and fifty centimes for each additional kilometer; for sending by courier express three francs and seventy-five centimes for the first kilometer, and for each additional kilometer thirty-seven and a half centimes.

From the preceding rules it will be seen that the tariff of charges on the lines in France, depends upon distance. On the reception of a message a charge is made, in the nature of a fee. This charge is 2 francs on each dispatch. Besides this, a charge of 10 centimes is made for each myriameter of the distance the message is to be sent. On a message from Paris to Marseilles, a distance of 67 myriameters, or about 400 miles air-line, the charge will be 8 francs and 76 centimes. The minimum of a message is fifteen words. Over fifteen words, for each series of five words or less, the charge is the full tariff of the 15 words, and in addition ten per cent.

To determine the tariff from any one place to another, a tape measure is placed upon the map of France, between the two points. The measure has marked upon it the myriameters, and thus in a right line the distance is known. The tariff is then estimated upon the distance thus acquired.

CONDITIONS OF ADMISSION AS A SUPERNUMERARY, INTO THE ADMINISTRATION OF THE TELEGRAPH LINES.

*(Enforced by Ministerial Decree.)*

ART. I. The personnel of the administration of the telegraph lines, is recruited by means of a competition among the candidates for the places of supernumerary station-masters. One third of the places, however, are reserved for discharged military men of all grades, who can read and write, and are less than thirty years of age.

ART. II. The competition for said positions takes place at Paris whenever the telegraph service requires.

ART. III. Candidates must be not less than 22 years of age, nor more than 28 years, and must prove their rank as Frenchmen.

ART. IV. At least one month before the time of competition, they must furnish the following evidences, viz. :

- 1st. Their certificate of birth.
- 2d. Certificate of discharge from military service.
- 3d. Certificate of good moral character.

ART. V. They must furnish satisfactory evidences of their knowledge of the following, viz. :

- 1st. The mode of making out official reports.
- 2d. Linear drawings.
- 3d. Arithmetic as far as proportions.



- 4th. Elementary geometry.
- 5th. Elements of chemistry.
- 6th. Elements of natural and physical sciences, especially in static and dynamic electricity.
- 7th. The drawing of plans.
- 8th. Leveling.

ART. VI. The knowledge of one or more of the following languages, viz.: German, English, Italian, and Spanish, will be a great consideration in the classing of the candidate.

ART. VII. The director-general of telegraphs will preside over the examining committee, which will be of one inspector-general, director-general, and two inspectors.

ART. VIII. The director-general of the telegraph lines is charged with the execution of the above decree.

PROGRAMME OF PREPARATORY EDUCATION REQUIRED OF CANDIDATES  
FOR THE PLACE OF SUPERNUMERARY.

(Fixed by Ministerial Decree.)

I. ARITHMETIC.

1st. Decimal numeration. 2d. Addition and subtraction of whole numbers. 3d. Multiplication of whole numbers. 4th. The product of several whole numbers not changed by inserting their factors. 5th. Division of whole numbers. 6th. To multiply or divide a number by the product of many factors, it is sufficient to multiply or divide successively by the factors of the product. 7th. Theory of prime numbers. 8th. Decomposition of a number into its prime factors. 9th. Greatest common divisor. 10th. Smallest number divisible by given numbers. 11th. Vulgar fractions. 12th. Operations with vulgar fractions. 13th. Decimal numbers. 14th. Operation with decimal numbers. 15th. To reduce vulgar fractions to a decimal, and *vice versa*. 16th. System of legal measures. 17th. Formation of squares and cubes with whole numbers, or vulgar or decimal fractions. 18th. Extraction of square and cube roots. 19th. Theory of proportions. 20th. Rule of three. 21st. Simple interest. 22d. Rule of fellowship. 23d. Allegations alternate and medial.

II. GEOMETRY.

1st. Right line and plane. 2d. Broken line and curved. 3d. Angles, triangles, and equilateral triangles. 4th. Parallel straight lines. 5th. Parallelograms, and the properties of their sides, angles, and diagonals. 6th. Circumference of the circle, cords and arcs. 7th. Condition of contact in intersection of

two circles. 8th. Measurement of angles—inscribed angles. 9th. Problems in the construction of triangles. 10th. Drawing of perpendicular and parallel lines. 11th. Use of the square and protractor. 12th. Verification of the square. 13th. Proportional lines. 14th. Similar triangles and similar polygons. 15th. To divide a given right line into parts proportional to the length given. 16th. To construct upon a given right line a polygon similar to a given polygon. 17th. Regular polygons. 18th. They may be inscribed and circumscribed by a circle. 19th. To inscribe a regular hexagon. 20th. The ratio of a circumference to its diameter, a constant number. 21st. Approximate valuation of the ratio of the circumference to the diameter. 22d. Measures of areas. 23d. Areas of similar polygons. 24th. Areas of a circle of a sector of a segment of a circle. 25th. Two right lines which cut each other—define a plane. 26th. Condition in which a right line is perpendicular to a plane. 27th. Parallelism of right lines and of planes. 28th. Measurement of problems of dihedral and trihedral angles. 29th. Of the parallelepipedon and its measurement. 30th. Pyramids and their measurements. 31st. Contents of a frustum of a pyramid. 32d. Of similar polygons. 33d. Of cones and cylinders with circular base. 34th. Lateral surface. 35th. Contents of bodies. 36th. Spheres. 37th. Areas of a zone. 38th. Areas of a whole sphere. 39th. Contents of the sphere section of a whole sphere.

### III. ENGINEERING.

1st. To trace a right line upon the ground. 2d. Measurement of a portion of a right line by means of a chain. 3d. Measuring by the metre. 4th. Drawing of perpendiculars. 5th. Use of the surveyor's square. 6th. Graphometer and its use. 7th. Drafting. 8th. Scale of reduction. 9th. Drawing by the plane. 10th. Sketching.

### IV. PHYSICS.

1st. Comparison and measurement of forces. 2d. Weights and measures. 3d. Equilibrium of liquids. 4th. Principle of the transmission of pressure. 5th. Measurement of density. 6th. Areometer. 7th. Atmospheric pressure. 8th. Barometer. 9th. Pneumatic machine. 10th. Areostat. 11th. Heat and dilation. 12th. Construction and use of thermometers. 13th. Density of gases. 14th. Freezing mixtures. 15th. Measurement of elastic forces. 16th. Of steam at different temperatures. 17th. Mixture of gases and vapors. 18th. Hygrometer. 19th. Rain and snow. 20th. Regular and

irregular winds. 21st. Fog and dew. 22d. Electricity. 23d. Conductors, non-conductors and power of points. 24th. Electricity by induction. 25th. Electroscope. 26th. Electric Machines. 27th. Electric batteries. 28th. Leyden jar. 29th. Electrometers. 30th. Thunder. 31st. Lightning rods. 32d. Return currents. 33d. Magnets. 34th. Poles of magnets. 35th. Process of magnetization. 36th. Armature of magnets. 37th. Magnetic needle. 38th. Magnetic meridian. 39th. Declination and inclination. 40th. Terrestrial magnetism. 41st. The compass. 42d. Batteries, and of their different kinds. 43d. Their organization. 44th. Theory of the batteries. 45th. Luminous and calorific and mechanical effects. 46th. Chemical effects of batteries. 47th. Galvanoplastic. 48th. Silvering and gilding. 49th. Decomposition of water by means of the battery. 50th. Dry batteries. 51st. Electro-magnetism. 52d. Deviation of the magnetic needle by means of a current of electricity. 53d. Attraction and repulsion of a magnet by means of a current of electricity. 54th. Galvanometer or multiplier. 55th. Currents produced by ordinary electricity. 56th. Magnetization by means of currents of electricity. 57th. Magnetization of soft iron by means of a current. 58th. Operation of magnetism in motion. 59th. Thermo-electricity and its theory. 60th. Electrical action of Daniel's and Bunson's batteries. 61st. Conductibility of metals. 62d. Laws of the intensity of the current in a homogeneous circuit, and also in a heterogeneous circuit. 63d. Intensity of currents and the laws of deviation.

#### V. CHEMISTRY.

1st. Simple bodies. 2d. Compound bodies. 3d. Nomenclatures. 4th. Acids, bases, and salts. 5th. Oxygen. 6th. Combustion. 7th. Azote. 8th. Atmospheric air. 9th. Hydrogen. 10th. Water. 11th. Carbon. 12th. Carbonic acid. 13th. Carbonized hydrogen. 14th. Gas for lighting. 15th. Azote gas. 16th. Amonics. 17th. Sulphur. 18th. Sulphuric acid. 19th. Sulphurous acid. 20th. Sulphuretted hydrogen. 21st. Phosphorus. 22d. Phosphoric acid. 23d. Phosphoretted hydrogen. 24th. Chloride. 25th. Chlorhydric acid. 26th. Salts in general. 27th. Laws of Berthollet. 28th. Calcareous earths. 29th. Hydraulic limes. 30th. Mortars and plasters. 31st. Potash. 32d. Soda. 33d. Sulphate of soda. 34th. Marine salts. 35th. Iron, zinc, tin, copper, and mercury, and their salts. 36th. Sulphate of copper. 37th. Of silver, gold and platina, and the character of their salts. 38th. Theory of metallurgy. 39th. Theory of mining, etc.

## CHAPTER LVII.

**Russian Government Telegraph—Categorical Arrangement of Dispatches—Regulations for Receiving and Sending Dispatches—Classification and Tariff of Charges—Regulation of the Clocks.**

### RUSSIAN GOVERNMENT TELEGRAPHS.

THE telegraphs of Russia are all government lines and under the minister of public buildings, ways, and communications. The lines were built by private contractors, and surrendered to the government from time to time, as completed.

There have been no efforts to extend the telegraph under private companies, nor is there any probability that such will be the case. To some readers many of the rules governing the transmission of dispatches on the lines in Russia, and other parts of Europe, may be considered as too severe and arbitrary. Practically such is not the case. In Russia the lines are open to individuals for their private business. Commercial affairs are not restricted. Full liberty and protection are given to every person in the transmission of domestic, social or business dispatches. It is to prevent the abuse of those privileges that the government has adopted the rules, which to the American reader may be regarded as too stringent. The following, issued by the minister of public buildings, ways, and communications, and approved, by His Majesty the Emperor, will give an idea as to the administration of the telegraphs in Russia :

#### CATEGORICAL ARRANGEMENT OF DISPATCHES.

1st. The dispatches transmissible over the telegraph, shall be divided into five categories, viz. :

- 1st. Orders from, and reports to, His Majesty the Emperor. Dispatches to and from royal families.
- 2d. Government dispatches, such as from the commander-in-chief, minister of foreign affairs, military governor-generals, governor-generals, military and civil governors, military commanders, and reports to the government.
- 3d. Dispatches of the administration of the telegraphs.
- 4th. Dispatches of the minister of public buildings, ways, and communications.

5th. Private dispatches, without regard to rank or condition. (The private dispatches of public functionaries belong to this class.)

REGULATIONS FOR RECEIVING AND SENDING DISPATCHES.

2d. The reception and sending of dispatches take place in the order of their presentation, except in cases under the first class before mentioned.

3d. Dispatches can only be received at the telegraph station, and in the apartment devoted to that purpose, except imperial messages, which are to be received at any of the palaces of His Majesty the Emperor.

4th. Under no circumstances can any one enter the operating room, unless employed therein.

5th. Dispatches are received every day, Sundays not excepted. Government dispatches can be received day or night. Private dispatches are to be presented at the station between the hours of 8 A. M. and 3 P. M.; after that hour the tariff is double. Between 3 P. M. and 8 A. M. dispatches can be received and sent by giving notice in advance, and the payment of the tariff of a dispatch. If the dispatch is not presented, the money is forfeited to the government.

6th. Every dispatch must be signed by the sender, and a detailed address must be given. It must be written only on one side of the official forms, furnished at the station, that the same may be filed, by pasting it in a book arranged for that purpose. All dispatches must be written with ink.

7th. Dispatches of the interior are to be written in the Russian language. From St. Petersburg to Warsaw, to Helsingfors, Cronstadt, Dunaburg and Riga, may be written in the French, German, or Russian language. Foreign dispatches may be written in French, German, Russian, or English language. Dispatches to and from members of the imperial family, and government dispatches, may be written in cipher, provided the cipher be composed of figures, Russian or Latin letters.

8th. Dispatches containing exchange news may contain ciphers, but the sender must explain the meaning of each cipher to the administration, and sign the same, giving a satisfactory guarantee as to responsibility.

9th. In no case whatever can a political dispatch be received.

10th. Government dispatches are not within the control of the station officers of the telegraph, and they cannot be stopped.

11th. Private dispatches containing anything contrary to the

laws, or incompatible with the public good, or containing objectionable language, cannot be transmitted. All such dispatches are strictly forbidden to be sent, and it is the duty of the officer of the station to transmit them forthwith to the minister of communications. Payment for them is to be refused. Should it happen that the dispatch be forwarded through inadvertence, it is the duty of any other station officer to stop its delivery, and to transmit it to the minister of communications. The money is to be forfeited to the government, if the dispatch is found objectionable. When a dispatch, as above described, is received from a foreign country, it is not to be delivered; but it must be sent to the minister of communications, and notice of that fact must be sent to the stations from which the dispatch originated.

12th. Any one aggrieved by any act of the telegraph, may address the minister of communications.

13th. Government dispatches and messages between imperial and royal families are unlimited. Private dispatches cannot exceed 100 words, unless the line is unemployed with other business. One person cannot send but one dispatch until the line has sent all others offered. Duplicate dispatches can be delivered in the same town by the payment of 20 copecks (15 cents), for each duplicate delivered. For copies sent to other stations, full charge is to be made.

14th. A sender of a dispatch may pay one fourth the tariff of a message, and he will be entitled to be informed by the station, the exact time of the reception of his dispatch, either at the destination station, or at the residence of the person to whom the message was sent. The price for sending back the message for collation, is one half the tariff of a message.

15th. The identity of the sender can be certified to, on a dispatch, by the station receiving the same. In such cases, the sending station adds the following, viz.: "The administration of the telegraph attests the identity of the sender." The charge for this certificate is 31 copecks (about 23½ cents). In case the director of the station does not know the sender of the dispatch, his identity can be established by a passport, foreign or local, or by some officer of a police tribunal.

16th. The maximum of a single dispatch is 25 words.

17th. No dispatch can be transmitted until it has been examined by the director of the station, whose duty it is to see that it does not contain any objectionable matter. When approved, it is sent.

18th. After a dispatch has been received and *in transitu*, if the direct line gets out of order, the sender is not to pay the

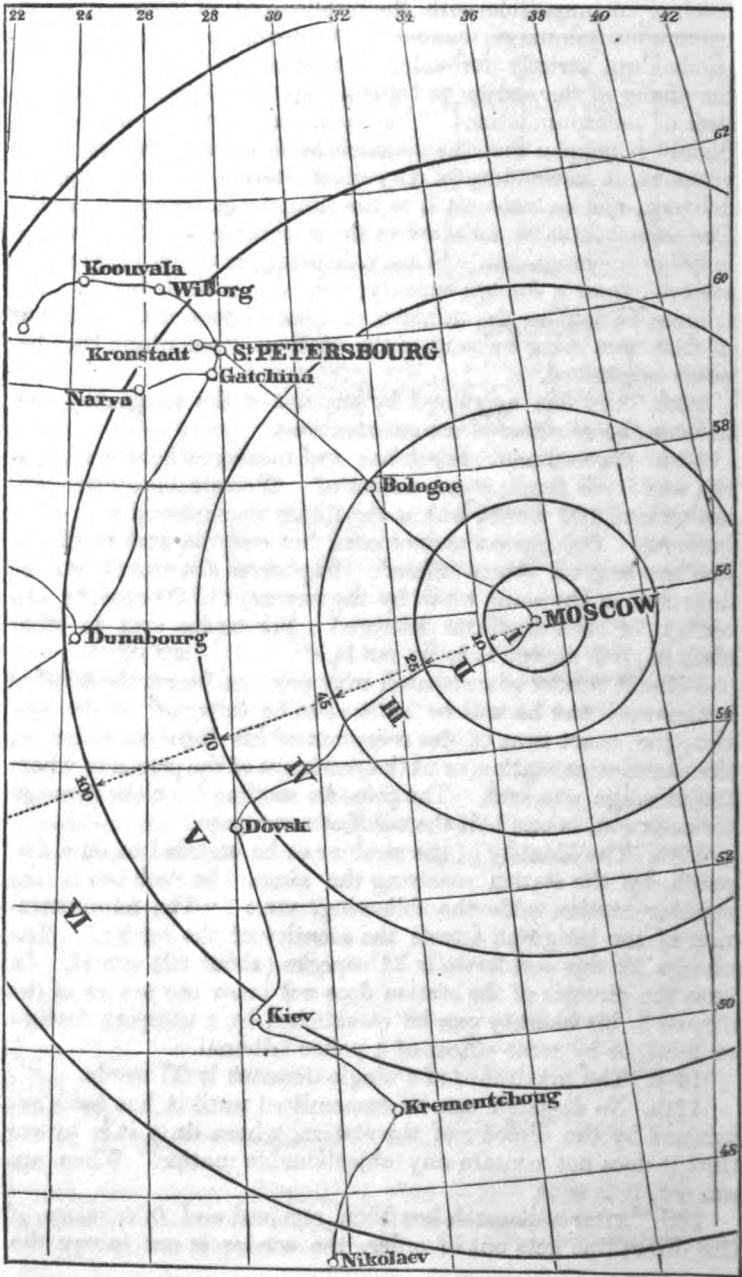

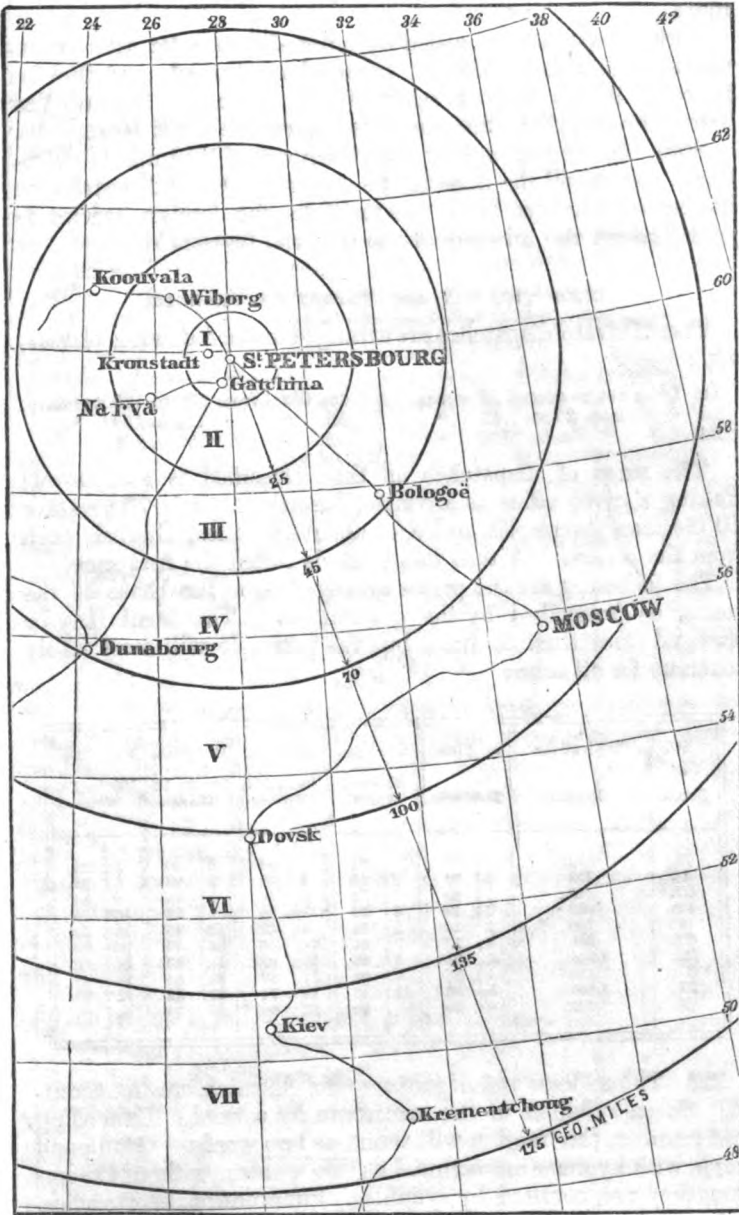



extra expense for sending the dispatch by a more circuitous route.

19th. Dispatches cancelled by order of the sender, after transmission and before delivery, cannot be returned, and the fee for cancelling is half the tariff of the message. If cancelled before transmission, the money is returned, except 15 copecks.

20th. All messages to or from members of the imperial family are free on all the lines in the empire. On all dispatches to be sent over foreign lines, the tariff for the foreign service is paid through the minister of the imperial household.

#### CLASSIFICATION AND TARIFF OF CHARGES.

21st. Private dispatches are arranged in the following classes, viz. :

|                                   |                                  |
|-----------------------------------|----------------------------------|
| 1st Class not to exceed 25 words. | 4th Class from 100 to 125 words. |
| 2d " from 25 to 50 "              | 5th " " 125 to 150 "             |
| 3d " " 50 to 100 "                | 6th " " 150 to 200 "             |

The price of dispatches as thus classified is as follows: Taking a given office as a centre, describe a circle 70 versts or 10 German geographic miles, or about 46 miles, English each from the centre. Within this circle is called the first zone.

The following are the prices arranged upon the bases of the zones, as prescribed by the government. This tariff may be changed from time to time, but the principle will most likely continue for all time :

| No. of Zones. | Width of the Zone. | 1st Class. |    | 2d Class.       |    | 3d Class.        |    | 4th Class.        |    | 5th Class.        |    |
|---------------|--------------------|------------|----|-----------------|----|------------------|----|-------------------|----|-------------------|----|
|               |                    | 25 Words.  |    | 25 to 50 Words. |    | 50 to 100 Words. |    | 100 to 125 Words. |    | 125 to 150 Words. |    |
| I.            | 70                 |            | 62 | 1               | 24 | 1                | 86 | 2                 | 48 | 3                 | 10 |
| II.           | 175                | 1          | 24 | 2               | 48 | 3                | 72 | 4                 | 96 | 6                 | 20 |
| III.          | 315                | 1          | 86 | 3               | 72 | 5                | 58 | 7                 | 44 | 9                 | 30 |
| IV.           | 490                | 2          | 48 | 4               | 96 | 7                | 44 | 9                 | 92 | 12                | 40 |
| V.            | 700                | 3          | 10 | 6               | 20 | 9                | 39 | 12                | 40 | 15                | 50 |
| VI.           | 945                | 3          | 72 | 7               | 44 | 11               | 16 | 14                | 88 | 18                | 60 |
| VII.          | 1,225              | 4          | 34 | 8               | 68 | 18               | 02 | 17                | 36 | 21                | 70 |
| VIII.         | 1,540              | 4          | 96 | 9               | 92 | 14               | 88 | 20                | 84 | 24                | 80 |
| IX.           | 1,890              | 5          | 58 | 11              | 16 | 16               | 74 | 23                | 32 | 27                | 90 |
| X.            | 2,275              | 6          | 20 |                 | 40 | 18               | 60 | 24                | 80 | 31                | 00 |

22d. The address and signature on a dispatch are not counted. Seven syllables is the maximum for a word. Exceeding that number, the fraction will count as two words. Compound words with hyphens are counted as two words; without the hyphen they are counted by syllables. Punctuation, apostrophes, and quotation marks, are free. Every separate letter, as "l," is

counted as a word. Numbers written separately are counted as words; but when united, five figures are considered as a word, and all points of punctuation, such as commas, semicolons, in the use of figures, etc., are counted each as a figure. Fractions of a series of five figures count as a word. The dash in fractions ( $\frac{1}{2}$ ) is counted as a figure; thus 260 $\frac{1}{2}$  counts as two words. In cipher messages five figures compose a word; if singly, each is a word; if together, the whole is divided by five to get the number of words chargeable. When figures and letters are run together, the whole is divided by five, as in preceding case. Prefixes to proper names count as separate words, such as "Von," "De," "La," "Van," "Der," etc.

23d. The tariff on cipher dispatches is fifty per cent. more than the charges on ordinary messages.

24th. If the sender does not pay enough for the transmission of a message, by fault of the officer receiving it, he cannot be made to pay the deficit, but the officer receiving the dispatch must pay the balance due, in the form of a fine. If the sender overpays on a dispatch, the amount must be refunded.

25th. In case a message is missent, lost, transmitted incorrectly, or fails to reach its destination in time, the sender has permission to petition the minister of communications, within six months, for the sum paid to be refunded.

26th. The officers of stations must report monthly to the minister of communications, a full account of their transactions.

#### REGULATION OF THE CLOCKS.

27th. All the clocks on the telegraph lines are to be regulated by the time in St. Petersburg. Each station is provided with a table showing the difference in time. Each station is required to correct its clock daily; thus before 8 o'clock, A. M., the director of the station in His Majesty the Emperor's palace, in St. Petersburg, commands "attention." At that moment the pendulum of every clock on all the lines must be stopped, and their hands placed at 8 precisely. Standing in the window of the Winter Palace above mentioned, the director, at 8 o'clock exactly, presses upon the signal key of his instrument, and at that instant the needle of the galvanometer at each station descends to its normal state, and the clocks are set in motion.

28th. After the fixing of the time, each morning, the directors of the respective stations transmit to the director at the palace, the business of the preceding day, embracing, 1st. Dispatches transmitted; 2d. Dispatches received; and 3d. Dispatches repeated *in transitu*.

## CHAPTER LVIII.

European International Tariff—English International Tariff—Rules and Regulations—The Hague Range—Rules and Regulations—The French Range.

### EUROPEAN INTERNATIONAL TARIFF.

THE tariff on international dispatches between most of the governments of Europe, has been regulated by two agreements: one was made at Berlin, June 29, 1855, and the other at Paris, December 29, 1855.

The first agreement embraced Austria, Prussia, Holland, and the whole Germanic confederacy. Russia, Turkey, and the Italian states—except Sardinia—have conformed to the rules adopted at the conventions.

1st. The basis of the tariff is as follows, viz.:

| DISTANCES.               |           | TARIFF OF CHARGES             |                                |                                 |
|--------------------------|-----------|-------------------------------|--------------------------------|---------------------------------|
|                          |           | From 1 to 25 words inclusive. | From 26 to 50 words inclusive. | From 50 to 100 words inclusive. |
| From 1 to 75 kilometers, | 1st zone. | 2½ francs.                    | 5 francs.                      | 7½ francs.                      |
| " 75 to 190 "            | 2d "      | 5 "                           | 10 "                           | 15 "                            |
| " 190 to 340 "           | 3d "      | 7½ "                          | 15 "                           | 22½ "                           |
| " 340 to 525 "           | 4th "     | 10 "                          | 20 "                           | 30 "                            |
| " 525 to 750 "           | 5th "     | 12½ "                         | 25 "                           | 37½ "                           |
| " 750 to 1015 "          | 6th "     | 15 "                          | 30 "                           | 45 "                            |

2d. The distances are computed in a straight line across each country. A single dispatch to be not above 25 words. The name of the forwarding station and the date are sent free. The address, when not exceeding 5 words, is free; beyond 5 words in the address, the additional is charged at the same rates as the dispatch. Every separate character or figure counts as a word. Numbers above 5 figures, represent as many words as they contain 5 figures, that is to say, five figures is considered equal to a word. Fractionals under 5 figures count as a word.

3d. The greatest length of a dispatch is fixed at 100 words. Beyond 100 words, commences a new dispatch, to take its turn with other dispatches. One person cannot send several dispatches in succession, except when no other dispatches are waiting for transmission.

4th. An acknowledgment of the receipt of a dispatch is charged one fourth the price of a dispatch of 25 words. If the whole dispatch is sent back in order to be collated, the charge

is to be one half of the price for a dispatch of 25 words. If the receiver of the dispatch wishes to collate the message, he will be charged the full price of a dispatch of 25 words.

5th. Answers may be paid for in advance, such answers not exceeding ten words (the five words for the address not to be counted), the charge to be half the tariff for a single dispatch. If the answer does not arrive within five days succeeding its demand, the charge made for it, less 25 per cent., is refunded.

6th. Dispatches to be forwarded to any number of intermediate stations, are to be considered as separate dispatches to each station, and charged in full.

7th. Dispatches, of which several copies are to be delivered in the town of the office to which they are sent,—full charge to be made for the first, and nine tenths of a franc for each additional copy.

8th. When any one, sending a message, wishes to prove his identity to the place to which his dispatch is sent, he must pay 1½ francs additional.

9th. Night dispatches are charged double in all places where night service is not permanent. No night dispatch is to be accepted unless notice thereof be given during the preceding day. A portion, not less than one half of the charge on a single dispatch, must be paid when the notice is given. If the dispatch is not presented in due time according to previous notice, the money paid is not to be refunded.

10th. The expenses of the delivery of dispatches are to be paid in advance. For the delivery by postal registration the charge is to be uniformly 15 centimes in the country in which the destination office is located, and one and a half francs for localities out of the country on the continent of Europe. Messages delivered within the circle of the locality of the destination office, a charge of two and a half francs is to be made, and to be paid in advance. Beyond the circle of the locality, where it is possible to employ horse express, the charge is to be 4 francs for each myriameter.

The second convention was concluded between France, Belgium, Spain, Sardinia, and Switzerland. The following table represents the tariff scale adopted, viz. :

| DISTANCES.                          | NUMBER OF WORDS.    |                                                         |
|-------------------------------------|---------------------|---------------------------------------------------------|
|                                     | From 1 to 15 words. | For each additional 5 words or fractions over 15 words. |
| 1st zone, from 1 to 100 kilometers. | 1½ francs.          | ½ franc.                                                |
| 2d " 100 to 250 "                   | 3 "                 | 1 "                                                     |
| 3d " 250 to 450 "                   | 4½ "                | 1½ "                                                    |
| 4th " 450 to 700 "                  | 6 "                 | 2 "                                                     |
| 5th " 700 to 1000 "                 | 7½ "                | 2½ "                                                    |

1st. Dispatches for private persons are of two kinds, *ordinary* and *urgent*.

The first, or *ordinary*, are transmitted under the rules described. The second, or *urgent*, are to be considered under special regulations, viz. : The sender must direct in writing the dispatch to be transmitted as "URGENT." The tariff for *urgent* dispatches is to be triple. The length of such dispatches are not to exceed fifteen words, the name of the office from which sent and the date to be free. Five words for address to be free, and all additional to be charged full rates for transmission.

2d. For duplicate dispatches delivered in the same town the charge is to be one franc for each copy.

3d. The rules adopted by the preceding convention, not in conflict with the above, to be adopted by this convention.

In the transmission of dispatches destined for Sweden, Norway, and Denmark, the rules of the first convention are applied as far as Hamburg, beyond which place the charges are special, and of the respective countries named. The following is the tariff to the respective capitals to and from Hamburg, viz. :

|                 | From 1 to 25 words.   | From 26 to 50 words.   | From 51 to 100 words.  |
|-----------------|-----------------------|------------------------|------------------------|
| Stockholm.....  | 9 francs 95 centimes. | 19 francs 85 centimes. | 29 francs 74 centimes. |
| Christiana..... | 10 " 24 "             | 20 " 17 "              | 30 " 12 "              |
| Copenhagen..... | 2 " 85 "              | 5 " 70 "               | 8 " 55 "               |

On dispatches for England, the basis adopted is the same as the rules embraced in the convention between France and Belgium, Sardinia and Switzerland.

All the towns in the United Kingdom are considered in the 5th zone, reckoning from Calais. The charge for a dispatch of fifteen words to any part of England is seven and a half francs. The charge on each additional five words or fraction thereof, is two and a half francs.

#### ENGLISH INTERNATIONAL TARIFF.

Between England and the Continent of Europe, through the Hague route, there is a separate arrangement from those described. The rules and section of the tariff herewith given, are not to be considered as fixed, as they are subject to continual change. I give them to show the mode of business between the countries mentioned, and though some of the rules and the tariff of charges may be changed from time to time, yet the general course of business in contradistinction with the telegraph in America, may be considered as permanent. These rules are of as late date as those adopted between France and the other continental governments.

The direct telegraphic connection between France and England, is through the submarine company, *via* Dover and Calais. That route is embraced in the rules given under the conventions with France. The following "Explanations," &c., relate to the route to Europe, *via* the Hague, in Holland, by the International Telegraph Company in connection with the pioneer company of the United Kingdom, the Electric Telegraph Company.

In the arrangement of this tariff, however, an opportunity is afforded, for the sender of a message to select the route over which he desires his dispatch to be transmitted, whether by the submarine cable to Calais, France, by the cable to Ostend, Belgium, or by the cable to the Hague, Holland.

EXPLANATION OF MARGINAL REFERENCES.

The letters which stand first in the margin denote the "Country," and at once show the route by which the message must be forwarded.

|                                                             |     |     |     |     |     |         |
|-------------------------------------------------------------|-----|-----|-----|-----|-----|---------|
| B—Belgium                                                   | ... | ... | ... | ... | ... | B route |
| F—France                                                    | ... | ... | ... | ... | ... | ditto   |
| G—Germany, or places belonging to the Austro-Germanic Union | ... | ... | ... | ... | ... | A route |
| S—Sardinia or Switzerland, direct, quickest, but dearest    | ... | ... | ... | ... | ... | C ditto |
| " ditto, indirect, but cheapest                             | ... | ... | ... | ... | ... | A ditto |

"B" route is only to be used in case of break-down on "A" and "C" routes.

The figure 1 or 2, in margin, directs attention to the rules and regulations followed by stations to which they are affixed.

The letters which stand next in the margin denote the language in which messages may be taken.

|   |     |     |     |     |     |          |
|---|-----|-----|-----|-----|-----|----------|
| D | ... | ... | ... | ... | ... | Dutch,   |
| E | ... | ... | ... | ... | ... | English, |
| F | ... | ... | ... | ... | ... | French,  |
| G | ... | ... | ... | ... | ... | German.  |
| I | ... | ... | ... | ... | ... | Italian. |

The languages taken at each station are indicated by initial letters in the margin, and NO OTHERS ARE ACCEPTED. The public, therefore, should be particularly requested to write their messages in one of these languages, and in case they fail to comply with this request, they should be informed that, although the utmost care will be taken to translate their messages correctly, the company cannot be held responsible for any mistakes which may arise from this cause.

Stations in italics are always open.

In case of "Interruption of Communication," messages must be forwarded by the route specified in the service message (SU) announcing the fact.

In such cases, the words "For answer from," "To" ("No. of Words") "Amount paid," &c., are to be telegraphed without charge.

TARIFF OF CHARGES.

TARIFF OF CHARGES.

[FORM]

THE SENDER TO DETERMINE THE "ROUTE" OF HIS MESSAGE, WHETHER BY "A" OR "C" ROUTE.

| See explanations. | From any of the Electric Telegraph Company's Stations in Great Britain to | "A" Route via Germany. |          |           | "B" Route via Belgium and Germany. |          |           | "C" Route via Belgium and France. |          |           |
|-------------------|---------------------------------------------------------------------------|------------------------|----------|-----------|------------------------------------|----------|-----------|-----------------------------------|----------|-----------|
|                   |                                                                           | NUMBER OF WORDS.       |          |           | NUMBER OF WORDS.                   |          |           | NUMBER OF WORDS.                  |          |           |
|                   |                                                                           | 1 to 25                | 26 to 50 | 51 to 100 | 1 to 25                            | 26 to 50 | 51 to 100 | 1 to 25                           | 26 to 50 | 51 to 100 |
| S                 | FG                                                                        | £ s. d.                | £ s. d.  | £ s. d.   | £ s. d.                            | £ s. d.  | £ s. d.   | £ s. d.                           | £ s. d.  | £ s. d.   |
| S                 | FG                                                                        | 0 19 6                 | 1 19 0   | 2 18 6    | 1 38 6                             | 2 70     | 3 10 6    | 1 38 6                            | 2 70     | 3 10 6    |
| S                 | F                                                                         | 0 19 6                 | 1 19 0   | 2 18 6    | 1 38 6                             | 2 70     | 3 10 6    | 1 38 6                            | 2 70     | 3 10 6    |
| F                 | F                                                                         | 1 38 6                 | 2 70     | 3 10 6    | 1 18                               | 2        | 3 4 6     | 0 17 6                            | 1 15 0   | 2 12 6    |
| S                 | S                                                                         | 1 1 6                  | 2 3 0    | 3 4 6     | 1 5 6                              | 2 11 0   | 3 16 6    | 0 18 6                            | 1 7 0    | ..        |
| G                 | FG                                                                        | 0 17 6                 | 1 15 0   | 2 12 6    | 1 7 6                              | 2 15 0   | 3 16 6    | 1 8 6                             | 2 7 0    | 3 10 6    |
| B                 | DF                                                                        | 1 5 6                  | 2 11 0   | 3 16 6    | 1 5 6                              | 2 11 0   | 3 16 6    | 1 7 6                             | 2 15 0   | 3 10 6    |
| F                 | F                                                                         | 1 1 6                  | 2 3 0    | 3 4 6     | 1 5 6                              | 2 11 0   | 3 16 6    | 1 7 6                             | 2 15 0   | 3 10 6    |
| G                 | FG                                                                        | 1 8 6                  | 2 7 0    | 3 10 6    | 1 7 6                              | 2 15 0   | 3 16 6    | 1 7 6                             | 2 15 0   | 3 10 6    |
| S                 | F                                                                         | 1 5 6                  | 2 11 0   | 3 16 6    | 1 9 6                              | 2 19 0   | 4 8 6     | 1 5 6                             | 2 11 0   | 3 16 6    |
| S                 | F                                                                         | 1 5 6                  | 2 11 0   | 3 16 6    | 1 9 6                              | 2 19 0   | 4 8 6     | 1 5 6                             | 2 11 0   | 3 16 6    |
| G                 | FG                                                                        | 0 18 6                 | 1 7 0    | 2 0 6     | 0 17 6                             | 1 15 0   | 2 12 6    | 1 5 6                             | 2 11 0   | 3 16 6    |
| G                 | S                                                                         | 1 1 6                  | 2 3 0    | 3 4 6     | 1 5 6                              | 2 11 0   | 3 16 6    | 1 5 6                             | 2 11 0   | 3 16 6    |
| S                 | F                                                                         | 1 5 6                  | 2 11 0   | 3 16 6    | 1 8 6                              | 2 7 0    | 3 16 6    | 0 19 6                            | 1 19 0   | 3 18 6    |
| F                 | F                                                                         | 0 9 2                  | 0 18 4   | 1 7 8     | ..                                 | ..       | ..        | ..                                | ..       | ..        |
| G                 | DEFG                                                                      | 1 1 6                  | 2 3 0    | 3 4 6     | 1 5 6                              | 2 11 0   | 3 16 6    | 1 5 6                             | 2 11 0   | 3 16 6    |
| S                 | FG                                                                        | 1 1 6                  | 2 3 0    | 3 4 6     | 1 5 6                              | 2 11 0   | 3 16 6    | 1 5 6                             | 2 11 0   | 3 16 6    |

## RULES AND REGULATIONS—THE HAGUE RANGE.

*The Austro-Germanic Telegraph Union, including Austria, Prussia, Bavaria, Saxony, Wirtemberg, Holland, Hanover, Mecklenburg-Schwerin, and Baden.*

1. A single dispatch, including the names and addresses of both sender and receiver, is to contain from one to twenty words. Half the price of a single dispatch is to be charged for every additional ten words or fraction of ten words.

2. Words must not exceed seven syllables; the overplus is to be counted as one word.

Compound words not coupled by hyphens are to count as one word.

Words coupled by hyphens are counted separately.

Words or letters, followed or preceded by an apostrophe, count as one word.

Hyphens, apostrophes, and other stops, are not reckoned.

Syllables, such as "Van," "Van-der," "de," "le," "l'," "s," "St.," and the like, which precede proper names or words, are counted as separate words.

Commas and parentheses are not reckoned. Words underlined count as two words. Marks indicating a *new line* count as words.

Signs or marks which cannot be telegraphed are spelt as words, and counted as such.

Example: ( ) " " ——— § &c.

That is, instructions must be given at the end of message, explaining which words are to be so marked; and these instructions must be counted and charged as part of the dispatch.

3. A single letter counts as one word.

Words, such as "Winemerchant," "Regentstreet," "Postoffice," "Lindendrapery," "Onepenny," "Threepence," &c., up to "Elevenpence," if written in one word, are counted as one; but if separated by hyphens, or separately written, they count as two words.

NOTE. — <sup>1</sup>"Telegraphenantwort," <sup>1</sup>"Bestmögichst," <sup>1</sup>"Dampfschiffschleppfahrtsgesellschaft," and the like, are to be counted as one word.

4. In private messages every separate group of five figures or less, count as one word; if a group of figures contain more than five, it reckons as two words up to 10 figures, and so on.

Compound numbers, written in figures, count in the same manner, the stroke or sign which divides them reckoning as a figure—thus:  $\frac{1}{2}$  is one word, and  $1\frac{1}{2}$  two words. 20s., 25s., 30s. 6d., 40s. 6d., 45s. 6d., and the like, count as one word.

Decimal points and signs of division count as figures.

5. Numbers, when written together in letters, as twenty-four, thirty-six, &c., are to be counted as syllables, and to be charged at the rate of seven syllables per word; the overplus, if any, to be counted as one word; but if written separately, as twenty four, thirty six, they must be charged as two or more words. This rule is also applicable to compound numbers, as one eighth, three sixteenths.

6. In secret (government cipher) dispatches, the ciphers and letters, as also the commas and all other signs used in "cipher writing," are counted together, and the sum divided by "three;" the quotient gives the number of taxable words, the surplus to be reckoned as one word.



Words inserted in secret dispatches count as such. Government messages may be written in any language.

NOTE.—Secret or cipher dispatches can be sent by Government only.

7. The names and addresses of both sender and receiver must be counted, as also all instructions for forwarding beyond the telegraph lines, which instructions must be placed immediately after the address of the receiver.

8. When a message cannot be delivered on account of insufficient address, information of the fact must be telegraphed to the sending station, and notice, if possible, must be given to the sender.

The sender is responsible for non-delivery caused by an insufficient address, and he can only complete it by forwarding a message to the receiving station, containing the necessary correction, for which the usual tariff charge must be made.

9. Messages addressed to more than one person in the same town, and containing the same subject-matter, are considered as one message; all the addresses are reckoned, and for every copy after the first a charge of "seven pence" is made.

Messages addressed to different stations containing the same subject-matter, are counted as separate messages; but in such cases every separate message is charged according to the aggregate number of words, including address and name from.

10. If the sender desires to attest the signature to his correspondent, the words employed must be inserted immediately after the name *from*, and counted as part of the message.

11. Answers to messages may be prepaid, but the sender must determine the number of words the answer is to contain; in such cases the instructions "Answer of \* \* \* \* words paid," must be inserted immediately after the address *to*, and must be charged as part of the message.

If the answer to a message contains more words than have been paid for, it must be charged to the party sending it as a new message.

If, after the expiration of ten days, the paid answer to a message has not been received, or in case the sender of the answer has paid for it as an ordinary message on account of an excess of words, the sender of the original message has a right to the return of his money after a deduction of 7*d.* having been made (a deduction of 5*d.* only will be made on messages to Holland). Claims for the return of money deposited for prepaid answers must be made within five days of the abovementioned ten days; if not made within these fifteen days, no notice will be paid to them.

12. All telegraph, messenger's, postage, and estafette charges must be paid by the sender of the message.

13. The telegraph administrators of the Austro-Germanic Union do not hold themselves responsible for the forwarding or delivery of a message within any given space of time—neither are they responsible for any loss which may arise from delay, error, or non-delivery of a message.

When a message is lost, or so mutilated and delayed as to frustrate the object of the sender, or when it reaches the parties later than it could have been sent by post, then the sender has a right to the return of his money, providing the claim be made within six months of the day the dispatch was forwarded.

If the error, loss, or delay, takes place beyond the lines of the Union,

the claim will be forwarded to the proper administration for investigation on behalf of the sender.

No money is returned upon messages which are delayed after leaving the telegraph lines, and which may be conveyed by post, messenger, or estafette.

14. A message and its charges may be returned to the sender upon payment of an "entry fee" of 7*d.* (5*d.* if to a station in Holland), provided the transmission has not been commenced, and the person applying for its withdrawal can be fully identified as the sender or his representative: should the sender of a message desire its withdrawal *during* or *after* the transmission, the following regulation must be observed:—

- a. If during the transmission, the message not having been entirely finished, its further telegraphing may be stopped, and it may be returned, but the charges must be *retained*.
- b. If *after* the transmission, the message having been entirely finished, it may then be recalled, supposing the delivery not to have taken place, but this must be done by means of a private message to that effect from the sender to the office of destination. The usual charge must be made for a message of this description, and the charges of the message withdrawn must be *retained*.

In each of the above cases the *original* message paper must be retained, and due care must be taken with regard to the proper identity of the sender.

15. The sender can be obliged to pay short charges; any overcharges made are in all cases returned to him on application.

PORTERAGE.—There are only three means of delivery on the Continent, viz., by post, foot messenger, or estafette. When messages, therefore, are addressed to places beyond the telegraphic termini, they must, without fail, contain positive instructions for forwarding them on, either by post, messenger, or estafette, and the proper charge made. In the event of the instructions not being in accordance with the above, or in the absence of any instructions, messengers will be sent on by post.

The charges for delivery in Holland *by post* (registered) to all places, 4*d.*; *by foot messenger* within a distance of 15 Dutch miles (equal to 9½ English miles), 1*s.* 3*d.*

*By Estafette*.—Deposit of 4*d.* per Dutch mile must be made. If sender has no idea of the distance he must make a sufficient deposit to cover the expenses of delivering; the surplus (if any) will be returned to him on application.

The charges by the Austro-Germanic Union stations are, *by post* (registered) to all places, 10*d.*

When a message is addressed to "post-office," "post restante," the usual postage of the country the place is in to which it is addressed, must be prepaid by the sender.

Charge for special messenger within a distance of two German miles (equal to 7 English miles), 2*s.* 6*d.*

Charge for messengers beyond 2 German miles or by estafette is according to the money actually expended. A deposit at the rate of 2*s.* 6*d.* per German mile must be made. If the sender has no idea of the distance he must make a sufficient deposit to cover the expenses, the surplus, if any, will be returned on application.

No charge is made for the delivery of messages *within* the town where the receiving station is situated.

A uniform charge of 1*s.* 9*d.* is made without reference to the number of words, for messages going by railway telegraph.

In Great Britain no charge whatever will be made for portorage,



Signs, or marks<sup>1</sup> which cannot be telegraphed, must be written as words and counted as such; thus— — “ ” ( )

Single letters or figures count as words.

3. Five figures, or ciphers, count as one word. Numbers containing more than five figures reckon pro rata, the overplus to be counted as one word.

Numbers written at full length in letters must be counted as words.

The letters or figures contained in cipher messages (which are only allowed to be sent by governments) are added together and divided by five; the quotient gives the number of words.

Words contained in cipher messages count as such; thus, a message containing 500 figures and 10 words—

$$\frac{500}{5} = 100 + 10 = 110 - 105 \text{ chargeable words,}$$

reckoning five free words for the address.

Points and stops used in the division of *cipher*-writing are not reckoned; thus,

$$26,895 - 28,901 - 34,562 = 3 \text{ words.}$$

4. Preliminary instructions, such as “Post from Paris,” “Repetition paid,” &c., &c., are not charged.

5. If the sender of a message desires to know of its safe delivery, half the usual price of a single message must be charged, and the words “Accusé de réception payé,” telegraphed in the preliminary instructions, gratis.

6. Repetitions of messages may be obtained by the sender for half-price; but if the receiver desires a repetition, he must pay as for a new dispatch.

The words, “Répétition payée” must be telegraphed in the preliminary instructions, free of charge.

7. The sender of a message may pay for the answer. If the answer does not arrive within five days, the money may be returned.

If an answer contains more words than have been paid for, the *sender* of the *answer* must pay the *difference*.

8. Messages containing the same subject-matter, addressed to different places, are charged as distinct messages; but messages of this description addressed to different parties in the same places are charged as *one* message, with an additional charge of 10*d.* for each address after the first.

All the addresses must be counted—five words *only* being free.

9. If the sender of a message desires to prove his identity to his correspondent, he must satisfy the counter clerk of it, and pay an extra charge of 1*s.*

The words “Identité prouvée” must be telegraphed in the preliminary instructions gratis.

10. The sender of a message can demand its withdrawal.

If it is in course of transmission, the charges must *not* be returned; and if it has arrived at the station of destination, but has not been handed to the receiver, it may be withdrawn upon payment of *half* the price of a single message additional.

11. Messages sent during the night to stations having no night service, are charged double, that is, *all* charges, of whatever nature, are doubled, whether for “Repetition,” “Identité prouvée,” or otherwise.

**PORTERAGE.**—By *post* (registered) within the country, 5*d.*; to other places, 1*s.* 2*d.*; beyond the Continent of Europe, 2*s.*; from any station in Spain to Gibraltar, 1*s.* 2*d.*

When a message is addressed to “post-office,” “poste restante,” the usual postage of the country the place is in to which it is addressed, must be prepaid by the sender.

By *foot messenger*, a maximum distance of 10 kilometres=6 English miles, 2*s.*

By *estafette*, deposits must always be made.

The charges will be communicated by the receiving to the sending station, as soon as they are known.

*Rules and Regulations, for Messages to Russia, Turkey, the Principalities, Tuscany, Modena, Parma, the Papal States, Naples and Sicily.—Counting Words and Syllables.*

1. A single dispatch is to contain from one to twenty-five words, a double dispatch from twenty-six to fifty, and a treble dispatch from fifty-one to one hundred words. Messages must not contain more than one hundred words—if the matter required to be forwarded exceeds that number, the overplus must be sent as a new dispatch.

2. Words must not exceed seven syllables; the overplus is to be counted as one word.

Compound words not coupled by hyphens are to count as one word.

Words coupled by hyphens are counted separately.

Words or letters followed or preceded by an apostrophe count as one word.

Hyphens, apostrophes, and other stops, are not reckoned.

Signs or marks which cannot be telegraphed are spelt as words and counted as such.

Example— ( ) “ ” ——— ◊ &c.

That is, instructions must be given at end of message, explaining which words are to be so marked; and these instructions must be counted and charged as part of the dispatch.

A single letter counts as one word.

Words such as “Winemerchant,” “Regentstreet,” “Postoffice,” “Linen-draper,” “Today,” “Tomorrow,” “Onepenny,” “Threepence,” &c., up to “Elevenpence,” if written in one word, are counted as one, but if separated by hyphens, or separately written, they count as two words.

“One shilling,” “Two shillings,” &c., &c., are always counted as two words; nor can this be evaded by writing “Twelvepence,” “Eighteenpence,” “Twenty pence,” &c.

NOTE.—“Telegraphenantwort,” “Bestmöglichst,” “Dampfschiffschleptahrtsgesellschaft,” and the like are to be counted as one word.

3. In private messages, every separate group of five figures or less count as one word; if a group of figures contains more than five, it reckons as two words up to ten figures, and so on.

Compound numbers, written in figures, count in the same manner, the stroke or sign which divides them reckoning as a figure—thus,  $1\frac{1}{2}$  is one word, and  $1\frac{1}{4}$  two words; 20|, 25|, 30|6, 40|6, 45|6, and the like, count as one word.

Decimal points and signs of division count as figures.

4. Numbers when written together in letters, as twenty-four, Thirty-

six, &c., are to be counted in syllables, and to be charged at the rate of seven syllables, per word; the overplus, if any, to be charged as one word. but if written separately, as twenty four, thirty six, &c., they must be charged as two words. This rule is also applicable to compound numbers, as one eighth, three sixteenths, &c.

5. In secret (government cipher) dispatches, all the signs are counted together, and the sum divided by five; the result shows the number of words—the overplus to be charged as one word.

NOTE.—Secret or cipher dispatches can be sent by Governments only.

Words inserted in secret dispatches count as such.

The signs of interpunction in secret, as in other dispatches, are not reckoned.

6. In all messages, the words comprised in the name and address of the receiver, when they do not exceed five in number, can be sent free of charge. Should the number of words in the receiver's name and address exceed five, the extra words are to be counted and charged for.

The name and address (if any) of the sender are still to be counted and charged for as at present.

When the answer to a message is prepaid, and such answer does not exceed ten words (exclusive of the five words allowed for the name and address of the receiver) such answer to be one half of the usual rates only.

When a message is received from the Continent, bearing notice that the sender has paid for a reply of ten or more words (exclusive of the usual five free words in address to) a note to the following effect must be inserted on the delivery form: "Answer of \_\_\_\_\_ words prepaid by sender—to be sent within five days." Should the sender of reply wish to send more words than the number prepaid, he must pay as for a new dispatch, and be informed that the deposit left by sender of original message will be returned to him.

7. Syllables, such as "Van," "Van-der," "de," "le," "l'," "s'," "St," and the like, which precede proper names or words, are counted as separate words.

8. The instructions for forwarding messages to places beyond the termini of the telegraph lines, the instructions for "Repetition," "Answer paid for," "Acknowledgment of receipt paid for," &c., are not charged.

9. Dispatches addressed to different stations, containing the same subject-matter, are counted as separate messages; but, in such cases, every separate message is charged according to the aggregate number of words, including address and name.

Dispatches addressed to more than one person in the same town, and containing the same subject-matter, are counted as one message. All the addresses are reckoned, and for every copy after the first, a charge of eighteen pence is made.

10. Should the sender of a message wish to prove his identity to his correspondent, he can do so by first proving it to the officials at the original station, and by paying an additional sum of 60 cent. (1s.). The words "Identity proved" are then to be inserted, and telegraphed immediately after the address of the message.

11. Half the usual rate is charged for repeating messages for the senders at the time the messages are sent; but should they wish to have them repeated afterward, the whole rate must be charged. At the beginning of such dispatch, the words "Repetition paid for" are to be signaled without charge.

If the receiver of a message desires it to be repeated, he must pay as for a new dispatch. The money deposited for such repetition must in no case be returned, but in case the repetition prove an error to have occurred in the *Original Message*, the receiver must be informed that the money for such original message will be returned to the sender on his making written application at the sending station.

12. The sender cannot be *obliged* to insert the day of the week, date or office from which the message is sent.

13. All secret messages, without exception, must be repeated, and the usual charge for such repetition made.

NOTE.—B D, secret, cipher, or single letter messages are repeated from station to station in transmission, and the sending station is advised of due delivery at the transmitting station for half price; but if the sender desires a copy of the repetition to be furnished to him from the place of destination, he must pay the rate of "two messages and a quarter." If he determines to pay this charge, it must always be sent after MM, "To be repeated from Vienna," &c. If, on the contrary, the sender is satisfied with the simple repetition from the transmitting station, nothing must be inserted after MM— nor must the sender be allowed to put the word "Repeat" after finishing his message, for in such cases the Government Telegraph consider such an indication tantamount to "Repeat from Vienna, &c.," and charge accordingly.

14. If the sender desires to know of the due delivery of his message, he can do so, by paying one fourth of the price of a single dispatch. In such cases, the words "Acknowledgment paid for" must be telegraphed.

15. If the sender of a dispatch desires to pay for the answer, he must determine the number of words such answer is to contain, and deposit accordingly.

In such cases, the words "For answer from \_\_\_\_\_ to (No. of words.) Amount paid \_\_\_\_\_" &c., are to be telegraphed with out charge.

16. No extra charge is to be made for messages telegraphed in the night to those stations which are open, and which are printed in italic.

If it be desired to send messages during the night to stations at which there is no night service, those for stations in Holland must be announced at the Hague, before 8.30 P. M.; and for stations in Germany, the Grand Duchy of Baden, and Denmark, before 8 P. M.; and it must be stated, at the same time, at what hour the dispatch will be sent.

NOTE.—Due notice will be given to all stations of "interruption of communication," immediately after receipt of which the sender must pay the full rates of "the route" over which his message is forwarded. This rule applies to all the Continent.

#### RULES AND REGULATIONS—THE FRENCH RANGE.

*Relating to Stations marked No. 2 in margin of Tariff, including France, Belgium, and Switzerland, and Sardinia when sent via France.*

1. A *single dispatch* is to contain from one to twenty-five words, a *double dispatch* from twenty-six to fifty, and a *treble dispatch* from fifty-one to one hundred words. Messages must not contain more than one hundred words.

2. COMPOUND WORDS.—Words must not be compounded. Such words as "chartre partie," "s'il," "l'," "del'," "voulez-vous," "J'ai," "est-il," "a-t-il," "c'est-a-dire," "J. Van den Brande Becker comte de Saint-Paul et Cie.," "Frankfort on Maine," "Aix-la-Chapelle," "Chalons-sur-Saone," &c., &c., must be counted separately.

3. Numbers, if written in figures, as 2 4 5 1 6 7, are counted at the rate of five figures to one word; but if written at full length, they are counted separately. When figures are written in groups, as 247: 656: 341789, those between each colon must be counted as one word, except the group contains more than five, when it must be reckoned at the rate of five figures to a word, the surplus to be counted as one word.

<sup>1</sup> <sup>2</sup> <sup>1</sup> <sup>2</sup> <sup>1</sup> <sup>2</sup> <sup>1</sup> <sup>2</sup> <sup>1</sup> <sup>2</sup> <sup>3</sup> <sup>1</sup> <sup>2</sup>  
Dix sept, dix huit, dix neuf, quatre vingt, quatre vingt dix, soixante dix,

and the like, must be counted separately.

4. The name of the sender, the name of the station from which the message is sent, and the day of the week, must in all cases be inserted, and the excess over five words in the address must be charged for.

5. The instructions for forwarding messages beyond the termini of the telegraph lines, the instructions for "Repetition," "Answer paid for," &c. are not charged.

6. MESSAGES TO SEVERAL ADDRESSES.—If a message be addressed to several parties in the same town, nine tenths of a franc will be charged for each duplicate delivered.

7. Dispatches addressed to different stations, containing the same subject-matter, are counted as separate messages; but, in such cases, every separate message is charged according to the aggregate number of words, including address and name from.

8. REPETITION.—In France, Belgium, and Switzerland, if the sender desires to have his message repeated, half the usual charge is made in addition; but if the receiver desires it, he must pay as for a new dispatch.

9. SAFE DELIVERY.—If the sender desires to know of the safe delivery of his message, he must pay the fourth of the charge for a single dispatch.

10. If the sender of a dispatch desires to pay for the answer, he must determine the number of words such answer is to contain, and deposit accordingly.

11. NIGHT SERVICE.—Night messages for stations *not printed in Italics*, must, if for France or Belgium, be announced at the Hague, before 8 P. M.; if for Switzerland or Sardinia, before 7 P. M., and double the usual charge paid; it must also be mentioned *at what hour* the message will be sent. The double charge for a "single message" must be deposited at the time the dispatch is announced. All night messages are charged double, whether for night stations or not.

The portorage or messenger fees, in Russia, Turkey, Modena, Parma, Tuscany, Papal States, Naples, Sicily, etc., are embraced in the following rules:

The charges for forwarding messages beyond the terminal telegraph stations must in all cases be paid by the sender, at the following rates:

*By Post (Registered).*—To places within the country where the telegraph station is situated, and from which the message is ordered to be posted - - - - - Os. 5d.  
To all other places on Continent, from ditto ditto - 1s. 3d.

*Post Restante.*—When a message is addressed to "Post restante," Post-office, the usual postage of the country the place is in to which it is addressed, must be prepaid by the sender.



*By Foot Messenger.*—No portorage is charged on the Continent for messages to be delivered within the town where the telegraph office is situated; but if the distance is 2, 3, 4, 5, or 6 miles from the office, and message is directed to go by foot messenger, then a uniform charge of 2*s.* is to be made. No delivery in Norway by foot messenger beyond one English mile from telegraph station; if for further distance, message must be ordered by post or estafette.

*By Estafette.*—A deposit must be made by the sender of 20 cents., or 4*d.* per mile (Dutch); 25 silver groschen, or 2*s.* 6*d.* per mile (German); and 30 cents., or 6*d.* per mile (English). The surplus of which, if any, shall be returned to the sender within five days.

NOTE.—Deposits for estafettes (of not less than 30*s.*) should in all cases be made where the sender is ignorant of the exact distance to be traveled over beyond the terminal station.

*By Railway Telegraph.*—A uniform rate of 1 fl. 20 cents., or 2*s.*

LANGUAGES.—On the Austro-Germanic lines, messages are received when written in English, French, Dutch, German, and Italian. On the Taunus Railway Telegraph, private messages are sent in German only.

On the Lübeck and Travemunde line, dispatches are received in French, German, and English. On the lines from Bremen to Brake, Elsfleth, Fedderwerdsiel, Oldenburg, Rastede, Varel, and Vegesack, dispatches are received in French, German, and English. On the line from Altona to Elmshorn, Neumunster, Kiel, and Rensburg, messages are sent in French, German, English, and Danish.

In Denmark, Norway, and Sweden, dispatches are received in English, French, German, Danish, and Swedish.

On the Belgian lines, messages are received in French, English, German, Dutch, and Italian. On the French lines, messages in English, French, German, and Italian, are received.

On the Corsica lines, English, French, German, and Italian. On the lines in Algeria, Africa, messages are sent in French, English, German, and Italian. In Switzerland, Sardinia, and Island of Sardinia, in English, French, German, and Italian.

On the Malta, and Corfu lines, in English, French, and German. On the lines in Spain, English, French, Portuguese, Italian, and Spanish. In Portugal, messages are received in English, French, Italian, Spanish, and Portuguese.

On the Russian lines, interior Russian only, foreign messages in French, German, English, and Russian. On the Moldavian, Servian, and Wallachian lines, foreign dispatches to be in French or German. In Turkey, French, English, and German.

On the lines in Modena, Parma, Tuscany, the Papal States, Naples, and the Island of Sicily, the messages to be in French or Italian.

# ORGANIZATION AND ADMINISTRATION OF ASIATIC AND AFRICAN TELEGRAPHS.

## CHAPTER LIX.

History of the Telegraph in Hindostan—Rules and Regulations on the Bengal Lines—Classification and Qualification of Employés.

### ASIA—HISTORY OF THE TELEGRAPH IN HINDOSTAN.

In the months of April and May, 1839, in the vicinity of Calcutta, Hindostan, an experimental telegraph line of twenty-one miles, embracing 7,000 feet of river circuit, was constructed by Dr. O'Shaughnessy. The enterprise in India, after this experiment, remained at rest until 1851, at which time a line of 15 miles overground and 15 miles subterranean was constructed. In 1852 a branch line was built from Calcutta to Magapore and to Kedgerie, some 80 miles long. In 1852, the Hooghly and Huldee rivers were successfully crossed, by which Calcutta was brought into connection with the sea. In the same year the government of India directed the construction of lines from Calcutta to Agra, to Bombay, to Peshawur and Madras, and since then lines have been extended to other places.

The telegraphs of Hindostan have been constructed by the government upon a more expensive and permanent scale than the lines of any other country. Upon these lines a needle system, invented by Dr. O'Shaughnessy, has been successfully employed. He has given evidence of its superiority, in working, over the instruments employed on the lines in England.

### RULES AND REGULATIONS ON THE BENGAL LINES.

The following rules, adopted on the telegraph lines of the government of Bengal, will show the mode of the management of telegraph lines throughout India :

1st. Until further orders, the services shall be conducted by the superintendent, in direct communication with the government of Bengal.

2d. The telegraph station shall be open continually, day and night, throughout the year, for the receipt and transmission of correspondence.

3d. The secretaries and under-secretaries of the government, superintendent of marine and his secretary, master-attendant and his assistants, collector of the customs, deputy collector and his assistants, are authorized to have their messages on public service conveyed, subject to *pro forma* charge, at the usual rates, taking precedence of all private communications. Other public officers having messages on public service to transmit, will apply to the superintendent; or, in emergent cases, to one or other of the officers above named.

4th. All ordinary shipping intelligence is to be transmitted in writing hourly to the superintendent of marine, and the master attendant. Important shipping intelligence is to be transmitted, immediately upon its receipt, to the same authorities.

5th. Printed reports of intelligence are to be issued at 10 A. M., 1, 4, and 7 P. M. These will be forwarded to the members of the government, secretaries to the government, private secretaries to the governor-general, and deputy governor of Bengal, superintendent of marine, master-attendant, register of seamen, board of revenue, collector of customs, superintendent of preventive officers, military board, postmaster-general, &c.

6th. Special notice of the arrival of any specified vessel is to be sent immediately to the residence or office of any person within Calcutta, requiring it, at a charge of four annas (6d.) in the case of a subscriber, and one rupee (2s.) in the case of any other person.

7th. In case of any irregularity, delay, or interruption in the transmission of messages, or the delivery of notices or reports, on public or private service, complaint should be made to the superintendent.

8th. Any officer, signaler, clerk, or other person employed in the telegraph stations, disclosing improperly the particulars or tenor of any message sent by telegraph, whether on public or private service, shall be dismissed, forfeiting all arrears of salary; and shall be declared disqualified from serving government in any capacity.

9th. Messages will be transmitted at the following rates:

[The rates are something higher, but arranged as on the American lines. Two syllables a word, and each additional syllable is counted as a separate word.]

10th. Between sunset and sunrise, the tariff of charges will be doubled, and the superintendent will be allowed to divide

the receipts, at his discretion, among the signalers who may be engaged in transmission of the messages.

11th. The transmission of messages gratuitously is prohibited on penalty of dismissal.

12th. Messages will have precedence in the following order, viz. :

*a.* Vessels in distress ; *b.* Mail steamers ; *c.* Public service ; *d.* Private service of subscribers ; *e.* Shipping business ; *f.* Private service of individual firms, not subscribers.

13th. Persons using the telegraph are admitted into the outer room of the office ; but no person, whether public officers or private individuals, will be admitted into the inner rooms. Visitors can be allowed access to the signal room only by the special order of the superintendent.

14th. No record or copy is to be kept of the nature or contents of any dispatch on business, but an entry will be made in the stational journal, in the following form, viz. :

Message from A—— B——.

Transmitted to ——.

Words 25, not more than two syllables each, Tariff —— Additional ——

Delivery —— Answer ——

Signed by Signaler C—— D——

15th. All fees are to be paid in cash, before the sending of the message. All receipts on this account are to be carried to the credit of the government, and to be accounted for in the monthly reports.

16th. Subscribers' privileges are obtained by firms and individuals, on payment of a subscription of eight rupees a month.

17th. The superintendent is vested with the power of appointing and removing all persons employed in the establishment. He may inflict fines for neglect of duty ; but should such fines amount in any month to more than one-fourth of the salary or wages of the persons punished, the case shall be especially reported for the orders of the government.

#### CLASSIFICATION AND QUALIFICATION OF EMPLOYEES.

18th. The administration or establishment consists of a superintendent, assistant, and workmen. The assistants are of four classes :

##### FIRST CLASS—INSPECTORS.

*Qualifications.*—A good English education, a correct knowledge of orthography, a perfect knowledge of the principles, construction, working, adjustment, protection, and repairs of the lines of conductors, and of all the instruments employed.

Quickness and correctness in dispatching and receiving signals, knowledge of Marryat's and Bedford's Marine and River Codes. Good character for sobriety, diligence, activity, and good habitual health. Salary to be 100 rupees (£10) per month, with 40 rupees for traveling expenses when employed out of Calcutta.

#### SECOND CLASS—READERS.

*Qualifications.*—A good English education, correctness in orthography; rapidity and precision in transmitting and reading signals by spelling, and with needle telegraphs; knowledge of the adjustment of instruments, and of Marryat's and Bedford's codes. Salary 55 rupees (£5.10s.) to 75 rupees (£7.10s.) a month.

#### THIRD CLASS—SIGNALERS.

*Qualifications.*—A good English education, correctness in transmitting signals, and proficiency in reading signals. Salary 27½ rupees (£2.15s.) a month.

#### FOURTH CLASS—PROBATIONERS.

*Qualifications.*—A good English education. A guarantee from a guardian or parent, of readiness to enter into apprenticeship, according to government act.

Probationers receive no pay, but are permitted to learn the practice of signaling at such stations as may be convenient, for a period of three months, when they will be subjected to an examination, and discharged if not found qualified for admission on the apprentice list. If employed at out-stations, or on temporary duty, they will receive pay at the rate of 16 rupees (£1.12s.) per month.

In the foregoing I have not referred to the construction of the lines, preferring to embrace that subject in another part of this work, especially as the peculiarities of the telegraphs in Hindostan are different from other parts of the world. The character of the country, the climate, and other considerations, have required from Dr. O'Shaughnessy the exercise of wonderful inventive powers. In this, he has fully met every difficulty. And though his works exhibit a strange novelty, yet he has consummated the enterprise with a degree of perfection, as to construction and administration, singularly novel.

The lines of Hindostan are the most substantial in the world. They are subjected to severe trials, and such, too, as are not common to other climes; among which, for example, is the annoyance from the monkeys playing and swinging upon the wires.

## APPENDIX.

### SAMUEL F. B. MORSE,

of New York.

SAMUEL FINLEY BREESE MORSE is the inventor of the American-Electro-Magnetic Telegraph. He was the eldest son of the Rev. Jedediah Morse, D. D., the author of *Morse's Geography*. He was born at Charlestown, Massachusetts, on the 29th of April, 1791. His mother's name was Breese. She was a descendant of the Rev. Samuel Finley, D. D., a former President of Princeton College. From this ancestor and his mother, Professor Morse derives his Christian name.

He graduated at Yale College in 1810.

Young Morse had a passion for painting so strong that, in 1811, his father sent him to Europe, under charge of Mr. Alston, that he might perfect himself in the art to which he desired to devote his life. He had letters to West and Copley, and soon had the satisfaction to excite the peculiar regard of the former, who was in the zenith of his fame. In May, 1813, his picture of the "Dying Hercules" was exhibited at the Royal Academy, Somerset House, eliciting much commendation. Auxiliary to the painting of this picture, he had moulded a figure of "Hercules" in plaster, which he sent to the Society of Arts to take its chance for a prize in sculpture. His adventure was successful, and, on the 13th May, 1813, he publicly received a gold medal with high commendation from the Duke of Norfolk, then presiding.

Thus encouraged, the young artist prepared a picture representing the "Judgment of Jupiter in the case of Apollo, Marpessa, and Idas," to contest the prize of a gold medal and fifty guineas offered by the Royal Academy in 1814. Being called home before the exhibition, his picture was denied admittance, because he could not attend in person. West, the president, to whom he exhibited the picture after it was finished, advised him to remain, and after the public exhibition wrote him that he had no doubt it would have taken the prize.

In August, 1815, Morse returned to his own country, flushed with high hopes, based on his success abroad. He opened his rooms in Boston, where he exhibited his "Judgment of Jupiter;" but for a whole year he did not receive a single offer for that picture or a single order for any other of an historical character. This was a cruel disappointment, for in that direction his ambition lay. Having thus far depended on means derived from his father, and seeing no prospect of independence in that line, he betook himself to portrait-painting, and in that pursuit visited various towns in New-Hampshire. In a few months, he returned with a considerable sum in money acquired by painting small portraits at fifteen dollars each.

On that trip he became acquainted with Miss Walker, whom he afterward married. He also fell in with a Southern gentleman, who assured him that he could get abundant employment in the South at quadruple prices.

On writing to his uncle, Dr. Finley, of Charleston, that gentleman gave him a cordial invitation to his house while he made the trial. He complied, and although for a time his prospects were gloomy, a portrait of his uncle finally attracted so much attention that orders at sixty dollars each came in much faster than he could execute them. With three thousand dollars in hand, and engagements for a long time to come, he returned to New-England and married Miss Walker. For four successive winters he returned to Charleston, in the practice of his art, where he was not only successful, but was respected and beloved.

In January, 1821, Morse, in conjunction with John S. Boyde, originated the "South Carolina Academy of Fine Arts," of which the late Joel R. Poinsett was president. It was incorporated, and had several exhibitions; but has been broken up for lack of adequate support.

Circumstances awakened anew Morse's ambition for distinction as an historical painter. He conceived the idea of painting the interior of the representatives' chamber in the Capitol at Washington, and raising a revenue by its exhibition. He located his family in New-Haven, and devoted eighteen months to the painting of this picture. It measured eight feet by nine, and contained a great variety of figures. Its exhibition, however, instead of producing an income, resulted in a considerable loss, and this with contributions, in common with his brothers, to discharge their father's pecuniary liabilities, swept away all he had accumulated at Charleston.

Morse then sought employment in New-York, and finally obtained from the corporation an order to paint a portrait of Gen. Lafayette, who was then in the United States. For that purpose he visited Washington; but in February, 1825, he was called home by news of the death of his wife. His labors upon this picture were further interrupted by the sickness of his children, and the death of his excellent father and mother.

Morse now made New-York his place of residence. In the fall of 1825, he was active in organizing a drawing association, which constituted the germ of the "National Academy of Design," of which he was president for many years after its organization. Though gotten up under great difficulties and amidst much controversy, this institution was eminently successful.

In 1827, Morse delivered, before the New-York Athenæum, the first course of lectures on the fine arts ever delivered in America.

In 1829, he again visited Europe, spending three years among artists and collections of Art in England, Italy, and France. In Paris, he painted the interior of the Louvre, copying in miniature the most remarkable paintings hanging on its walls. In the fall of 1832, he returned to the United States, and resumed his position as President of the National Academy of Design, to which post he was elected every year during his absence.

When American artists were to be employed to fill with a picture one of the vacant panels in the Rotunda of the Capitol, the American artists, it is believed without exception, considered Morse best entitled to the honor; and great was their disappointment when another was selected. They exhibited their sense of the wrong done him by voluntarily raising a subscription to pay him for a picture suited to such a national object. A considerable sum was collected and paid over to him, but not enough to enable him to complete the design in a manner satisfactory to himself. Determined that no man should have an opportunity to charge him with

appropriating his money without an equivalent, he resolved to refund the amounts paid over to him; and though sorely pressed never ceased his efforts until he had paid back the last cent.

Professor Morse, under the most straitened circumstances, had an insuperable repugnance to contracting debt, or living on the bounty of others. His dying mother, after encountering much suffering from the kindness of his father in lending his name to friends whom he trusted, exacted a promise from her son that he would never thus endanger his own peace of mind and the comfort of his household, and to that promise he has religiously adhered.

During his collegiate course, ending in 1810, Professor Morse had been instructed by Professor Silliman in all that was then known on the subject of electricity, and the formation of electric batteries. During the residence of his family at New-Haven, or about 1824, enjoying the friendship of Professor Silliman, and having free access to his Laboratory, he obtained from those sources full information of the progress of electrical discovery and science from 1810 up to that time. In the winter of 1826-27, he attended a series of lectures on electricity, delivered by Professor Dana in New York, and there saw the first Electro-Magnet which probably was ever exhibited in America. Dana was an enthusiast on the subject of Electro-Magnetism, and being an intimate friend of Morse, made it a topic of constant conversation. Had not death struck him down, in the spring of 1828, he would probably have become the leading electrician of America.

In the month of October, 1832, Mr. Morse sailed from Havre for America. It was on that voyage that he invented the telegraph. He made drawings of the apparatus. The Supreme Court of the United States has on file conclusive proof that the subsequent telegraph was identical with the drawings made in his sketch-book on board of the ship Sully in 1832. The particulars in regard to the progress Mr. Morse made in his telegraph subsequent to 1832, have been given elsewhere in this work, and their repetition is unnecessary.

In 1837, he commenced active efforts to get his system adopted for the government use. He filed a caveat for his invention in the Patent Office in October of that year, and at the subsequent session of Congress he applied for the aid to test its practicability, but in this effort, however, he was not successful.

In 1838, the Hon. F. O. J. Smith, then a distinguished member of Congress, from the State of Maine, abandoned his seat and entered into the new enterprise with Prof. Morse; and in May of that year they sailed for Europe, having in view the procuring of patents and the selling of the invention to the different governments.

In England, the patent was refused, because a description of the invention had been published prior to the application. In France, a patent was granted, but by royal order it could not be placed in operation before its expiration. Efforts were made to get it established in Russia, but without success. Having remained in Europe for about a year without effecting anything, Prof. Morse abandoned further effort and returned to America.

In 1840, he procured his first American patent, and he then, in co-operation with his partner, Mr. Smith, endeavored to get the telegraph established by the United States Government.

At the session of Congress, ending in March, 1843, the bill appropriating thirty thousand dollars to test the practicability of the telegraph on an experimental line to be constructed from Washington to Baltimore was passed and became a law. This line was completed in May, 1844, and the successful operation gave evidence to the world of the most complete triumph.



In the year 1845, Professor Morse again visited Europe, for the purpose of getting his telegraph adopted by Russia or some of the other governments. Having arrived in Hamburg, late in the summer, he found that he could not make the visit to Russia and return before the close of navigation. He abandoned his intentions, and visited Paris, and in a few weeks thereafter returned to America.

While Professor Morse was at Paris, he made the acquaintance of Mr. Daguerre, and saw his wonderful discovery. As was natural with a devoted and discriminating artist, he soon found himself an enthusiast in the new art. He supplied himself with the necessary apparatuses and brought them to America.

Not long after his return to his home, he commenced the art of daguerreotyping. It was the first introduction in America of that novel art. He continued in this new vocation about one year, when he abandoned it to others, and from that time he has devoted his life to the telegraph.

The progress of the telegraph was a part of the career of Professor Morse. To embrace its advancement over the continents would require more space than is possible to be given in this volume. Wherever his system is seen—and they are scattered nearly over the whole civilized world—the instruments serve as orators, speaking praise to his name and honor to his nation.

The Morse system has become nearly the sole telegraph used on the American lines. Throughout Europe it is in general employment, most of others having been abandoned. Nations have laid aside their pride for their own peculiar contrivances, and adopted the Morse telegraph as the most practical for governmental and commercial purposes. These are manifestations of honor, deserving of the highest appreciation.

Besides the honors just above alluded to, Professor Morse has had conferred upon him, by the voluntary will of the respective sovereigns, various medals and orders. He has been created knight of the first class of the Turkish order, Nishan-Iftichar, Knight of the Danish order of the Danebrog, Chevalier of the French Legion of Honor, Knight Commander of the Spanish Order of Isabella the Catholic, &c., &c. He has been constituted a member of the Swedish Royal Academy of Sciences of Stockholm; of the Belgian Academy of Fine Arts; and honorary member of various American and Foreign Scientific societies.

Wherever Professor Morse has visited, in either hemisphere, and the isles of the seas, he has been received and respected with the greatest distinction. Many ovations have been given in his honor, and society has appreciated his presence as one of the greatest of the age. His fame has spread throughout the world, and it will stand with increased lustre as long as time lasts.

The most distinguished honor that has ever been conferred upon any one person, has been awarded to Professor Morse, in the assembling of the representatives of ten of the governments of Europe, in special Congress, for the purpose of testifying to him their appreciation of his telegraph.

This Congress met at Paris in 1858, and was composed of representatives from France, Russia, Austria, Sweden, Roman States, Turkey, Sardinia, Holland, Belgium and Tuscany. The Congress refused to look at the subject as to value, because a commercial consideration would have given Morse millions, but as an honorary testimonial for the good he had done man, they awarded to him the sum of four hundred thousand francs. This result was announced "*de titre une gratification honorifique, et toute personnelle.*"

Professor Morse married Miss Lucretia Pickering Walker, 29th of

September, 1818. He had five children by this wife, three of which are still living. Mrs. Morse died on the 7th of February, 1825. This sad occurrence was a heavy blow to the companion of the departed. On the 10th of August, 1848, Professor Morse married his second wife, Miss Sarah Elizabeth Griswold. He has four children by this lady.

Professor Morse now resides in the vicinity of Poughkeepsie, New-York, and he has everything around him calculated to render his later days happy. He is blessed with an amiable wife and promising children. He is surrounded with friends, and no one can be found that wishes him an unpleasant pang. His life has been one of temperance, industry, and religion. His benevolence has exceeded his abilities through his whole career. A reward awaits him, richer and purer than all the world can bestow.

## AMOS KENDALL,

of the District of Columbia.

AMOS KENDALL was born in Dunstable, in the State of Massachusetts, on the 16th day of August, 1789. His ancestors were farmers, and he labored on his father's farm until he was about sixteen years old. His fondness for books, and progress in the free schools of the neighborhood, excited in his father a desire to give him a collegiate education.

He was fitted for college, partly in New Ipswich, N. H., and partly in Groton, Mass. In August, 1807, he entered the freshman class of Dartmouth college, and graduated in August, 1811. For want of means, he was unable to attend the fall terms, and having supplied himself by teaching school in the winter, and kept up with his class by studying in the long evenings, he joined the class in the spring, so that he entered college five times within the four years. He graduated at the head of a large class.

Immediately after graduating, Mr. Kendall commenced the study of the law, at Groton, Mass., in the office of Wm. M. Richardson, Esq., who afterward became chief justice of New-Hampshire. This step was taken at the instance of Mr. Richardson himself, who learning that young Kendall was without means, proposed to take him into his office and family, allow him sundry perquisites, and depend entirely on the future for his compensation.

In consequence of the war with Great Britain, the practice of the law was very much depressed in New-England, and having no prominent family to sustain and advance him, Mr. Kendall determined to seek his fortune in the South or West. Mr. Richardson was then in Congress, and in February, 1814, Mr. Kendall went to Washington, and after spending there a couple of weeks, collecting information by means of his friend and patron, started for the West. He travelled to Pittsburg in the stages, spent two weeks there, descended the Ohio river in a flatboat to Maysville, Ky., thence in a skiff to Cincinnati, and thence he went most of the way on foot to Lexington, Ky. Accident there made him acquainted with the family of Henry Clay, who was then in Europe, and under an arrangement with Mrs. Clay, he became family tutor to her children for nearly a year. He then settled in Georgetown, Ky., in the practice of the law, and was soon afterward appointed postmaster there. It was not until after he settled in Georgetown, that he first saw Mr. Clay.

A slight incident here gave direction to his subsequent life. A club of young men, associated for mutual improvement in speaking and composition, existed in the neighborhood, which he joined upon invitation. A piece of composition read by him in the club, attracted attention, and produced solicitations that he would write for the village newspaper. His productions attracted attention, and led to an invitation to purchase an interest in the State paper at Frankfort, called the "*Argus of Western America.*" After some hesitation he made the purchase, and in the fall of 1817, became in effect the sole editor of that paper. It was not his purpose to abandon the practice of law, though by no means pleased with it; but one exciting question after another arose in State politics which engrossed his mind and weaned him from the law altogether.

In the contest for the Presidency, which ended in the election of John Quincy Adams, Mr. Kendall supported Mr. Clay, avowing that General Jackson was his second choice. In the subsequent contest between Mr. Adams and General Jackson, he zealously supported the latter. In March, 1829, he was, without solicitation on his part, appointed by General Jackson, Fourth Auditor of the Treasury Department at Washington. There was much confusion and corruption in this office, all of which was rectified by Mr. Kendall, who held the office five years. He was then unexpectedly solicited by General Jackson to take charge of the Postoffice Department, whose affairs were much deranged. Reluctantly, and only because the President placed his request on personal grounds, Mr. Kendall undertook the herculean task of reforming that department. In one year it was efficiently organized, purged from abuses, and freed from debt. He held the office until 1840, when he resigned. He was much persecuted by malicious suits instituted by certain mail contractors whose exactions he had resisted; but, after years of annoyance, they ended in his triumphant vindication, and the payment to him by the unanimous concurrence of all parties in Congress, of all costs and expenses which they had occasioned.

Much has been said about Mr. Kendall's influence with General Jackson. That the General had great confidence in him, is shown by the trusts committed to his hands. But in his public measures, General Jackson was a man, who, having once formed his opinions, might be *aided* but not *influenced*. That Mr. Kendall did aid him by his pen and counsel, particularly in his warfare with the Bank of the United States, there can be no doubt. Mr. Kendall's opinions in relation to that Bank were fixed as early as 1818, and perfectly accorded with General Jackson's, and he considers the aid he was able to render the General in destroying the Bank the highest title he has to the gratitude of his country.

Mr. Kendall left public life poor, and betook himself to the publication of a newspaper for subsistence. In this he was but partially successful; and not being able to transfer his establishment to a more promising field on account of embarrassments arising out of the malicious suits already alluded to, he discontinued his newspaper, and resorted to the prosecution of claims against the government, to him a most irksome business.

While thus employed, he fell in with Professor Morse, who was endeavoring, with little prospect of success, to get an appropriation from Congress, to extend a line of his telegraph from Baltimore to New-York, it being already in operation between Washington and Baltimore. Finding the Professor much discouraged, he inquired whether he had no project to render his telegraph profitable as a private enterprise if he should fail in obtaining further aid from the government? On being answered in the negative, he rejoined that if the appropriation failed, he would be glad to talk further on the subject. It failed, and Professor Morse asked Mr. Kendall for a proposition to take charge of his telegraph business. It was made and at once accepted. It vested Mr. Kendall with full power to manage and dispose of Morse's patent rights according to his discretion. A similar arrangement was made with Professor L. D. Gale, who owned one sixteenth, and Mr. Alfred Vail, who owned two sixteenths of Morse's patent. Without going into the details of his management, suffice it to say that it has placed Professor Morse in a condition of pecuniary independence, has profited in the same proportion the other owners of the patent, and has secured to himself and family the means of comfort.

Mr. Kendall was married at the age of 29, lived with his wife five years, and had four children, of whom only one survives. After living a widower two years, he was again married, and by his second wife has had ten children, of whom four with their mother still survive.

His habits are domestic, and he has always been happy in his family. Though of a feeble constitution, and often disabled by sickness, Mr. Kendall is nearly "three score and ten," with apparently as good a prospect of life's continuance as he has had for the last thirty years.

It is nearly twenty years, since Mr. Kendall abandoned active political life, though he has never lost his interest in the nation's welfare, and he still holds to the same political doctrines which he advocated with great power in his earlier life. The duties devolving upon him as the attorney for Professor Morse, have engaged the whole of his time and energies. None, save those who have been connected with the telegraph, can have a correct idea of the immense amount of labor performed by Mr. Kendall in the enterprise. He has travelled thousands of miles, to various parts of the country, and at all seasons of the year, attending negotiations, or trials in the federal courts in the States, and ably defending the rights of his client as the inventor of the American telegraph. It has been to Mr. Kendall a period of most extraordinary labor, and yet he has performed his whole duty with the most remarkable skill.

For upward of twelve years, I have been connected, more or less, with Mr. Kendall in the extension of the Morse telegraph lines throughout America, and in all the various relations in which I have been called to act, wherein he has been concerned, I have always found him to be correct and undeviating, ever maintaining a rigid adherence to truth, and opposed to its distortion or slightest evasion. I confess myself much indebted to his example for the course of my own life, and in asking his advice from time to time, whether upon public or private affairs, I have always found his views sustained by the highest points of morality. He has been prompt and strictly faithful in the discharge of all his obligations. He has never been known to deviate from an engagement for his own gain, but on the contrary he has been liberal in the interpretation of contracts resulting unprofitably to others.

In society, Mr. Kendall has exercised much influence. His moral teachings are fully appreciated by all who know him. He is not a professional member of the church, though a constant attendant of the Christian service.

In concluding this brief sketch of the Hon. Amos Kendall, it is proper to add, that it is impossible to do the subject justice in the small space allowed in this work. His life has been remarkable. He has probably been the most persecuted man in the nation, and yet his pathway through his whole life has been lighted by principles of high toned morality, so brilliant indeed, that his opponents seem to have been blinded by their reflecting rays.

The annals of the nation may be searched in vain for his superior in patriotism, or for one more illustrious and worthy of example to coming generations.

## FRANCIS O. J. SMITH.

of Maine.

THE subject of this memoir was born in Brentwood, in the county of Rockingham, State of New Hampshire, on the 23d of November, A. D. 1806. His ancestors, on both the paternal and maternal side, were among the early settlers of that township, and the township of Greenland, in the same county, bordering upon the Piscataqua river. They are believed to have originated in Scotland. The maternal family name was Bean.

The father of Francis O. J. Smith was educated for mercantile pursuits (which he subsequently followed) at Phillips' Exeter Academy, where so many of the sons of New Hampshire and of other States acquired the rudiments of their subsequent distinction in life. This his only son also was educated through the regular courses of study at the same institution, for admission as junior to a collegiate class; but alike from disinclination, and want of the requisite pecuniary means, he pursued that system of education no further, but entered upon the study of law, at about the age of fifteen, in the office of the late Hon. Ichabod Bartlett, in Portsmouth, N. H., with whom he continued nearly two years, and thence accompanied the removal of his father's family to Westbrook, in the immediate vicinity of Portland, Maine. Shortly after, he recommenced the study of the profession of law in the office of Messrs. Fessenden & Deblois, then, and for many years subsequently, a leading firm in the profession, in Portland. His father's residence in Westbrook was about two miles from the office of Messrs F. & D., in Portland, and, to indicate the toil of the upward progress of this then young man, I may remark, that for months in succession he walked to and fro that distance, morning and evening, limiting himself to two meals per day whenever he did not elect to double his daily travel. Necessity begat the inclination, and both doubtless contributed to his welfare. His uniform habits of sobriety and industry, and his marked familiarity with and turn for business, and total seclusion from social indulgences, very early secured to him the special confidence of his professional tutors, and imparted to him the consideration, among all his acquaintances, of much more advanced years than he had actually attained. These characteristics, probably, operated to shut out all questions respecting his age, at the time he submitted his claims and qualifications to the members of the Cumberland bar for a recommendation to the court for admission to practise; and no rule of qualification, founded in age, was then in force, to render any disclosure on his part necessary. In March, 1826, preceding his arrival at the age of twenty years in the following November; or, when he was only about *four months in advance of nineteen years of age*, he was honorably admitted to practise as an attorney at law, by the justices of the Common Pleas Court for Cumberland county. He immediately opened an office in Portland, and soon found himself favored with an encouraging practice, which brought him, however, into professional antagonism with those who were by many years his seniors, and among them the ablest advocates at that bar, then, the most eminent in the State. He has often acknowledged the forbearance with which these leading minds of the profession, with whom he was thus early brought in contact, must have treated him, and encouraged his aspirations. Of this number, besides his own immediate

tutors, Messrs. Fessenden & Deblois, was the astute Longfellow, the learned Hopkins, the sagacious Greenleaf, the facetious, yet thoughtful and dignified Emery, the courtly Kinsman, and the benevolent Adams. The records of the courts in that county bear testimony, that our strippling minor stood in the midst of those professional Goliaths without suffering any retrograde in his reputation as a student or an advocate, but, with a constantly increasing practice, approximating that of the largest among them, up to the period when he yielded to the engrossments of politics.

I learn, that at that early day, he entertained an exalted idea of the vigorous growth that awaited the Western States, and had resolved to seek his home and fortunes in them. From this purpose, however, he was most unexpectedly diverted, by being drawn into an embittered feeling of personal hostility toward himself on the part of a score or more of lottery ticket venders, whose business was then of commanding influence in Portland. It arose from his being professionally retained against one of these firms, by a simple but honest man from an interior town, who was believed at the time to have been designedly defrauded in the purchase of a fictitious lottery ticket. But a common cause was made by the venders, first against the complaining man, and next against his professional adviser, accompanied, in respect to the latter, by threats of personal violence, professional ruin, and remediless disgrace; all of which awakened in the young lawyer a resolution and an energy, of which his assailants had taken but a partial reckoning. In fact, he had not himself measured his own vigor previous to that occurrence. Many of them had been esteemed previously among his professed friends, which made their treatment of him so much more exasperating to his unsubdued and resentful spirit. He was young, and dependent on his own reputation wholly for success, without family influence to protect him. But he felt the more keenly this attempt to force him to abandon an innocent and injured client against his sense of duty. Passing over many details of this acrimonious contest, suffice it to say, that it resulted in the *indictment* and conviction for illegal sales of tickets, of about twenty of the leading and wealthy lottery venders, then in full influence over the business and sentiments of the town, and in a triumphant vindication of himself throughout all his unpleasant relations to the controversy. This sudden assault upon his personal independence was the occasion of his first attempt at *pamphleteering*; as the large advertising patronage of the ticket venders shut his side of the case entirely out of all the newspapers in the town, and secured the use of them against him, leaving him for being heard at all by the public ear, the sole alternative of publishing a pamphlet at his own expence, and exposing the dangers, corruptions, and ruinous policy of the whole lottery system. It was a full and elaborate dissection of the whole trade. Whether this production had or not the effect to awaken the public judgment to an acknowledgment of those fearful influences of the lottery system, I do not undertake to decide. But sure it is, that the public mind became aroused on the subject, and the entire system was soon after swept away by legislative prohibitions, and has never been reinstated in any part of the State, and much less had any sanction of law.

It is a notable fact, indicative of the well-balanced temperament which at that early day characterized Mr. Smith, that of nearly twenty principals, who were thus arraigned under his complaints, amidst the most excited feelings of personal hostility toward him, in subsequent years with a single exception every one of them became his decided friend, and the excepted one sent from his dying bed to Mr. Smith, his "forgiveness and blessing!" One only of the number survives at this day, and bears willing testimony to the accuracy of this presentment of the facts.

It will be remembered by men of that day, and by the student in political history, that immediately upon the election of Mr. Adams as President of the United States, by the House of Representatives of the United States, over General Jackson, an active campaign was commenced at Washington, and soon after was lighted up in the South and West, to question the integrity of their action, and to arouse the public mind against Mr. Adams' administration and to secure the election of General Jackson in 1828. This feeling found but little active sympathy in the Eastern States, for the first two years of its progress in the South and West, and middle States.

At that time, political party lines had not been restored from the buried condition into which they were sunk by the general understanding of the people of Maine, as the basis of their concurrence in securing the admission of Maine into the Union as an independent State. This hostile armistice between the old contending parties of federalism and democracy was still in force in 1826-'27, when Mr. Smith's attention was first drawn to public measures. The government of the State, and its representation in both Houses of Congress, were consequently then made up indiscriminately from the ranks of both old parties. There was, nevertheless, a strong tone of dissatisfaction perceptibly pervading the popular mind of the State, toward this mongrel character of the politics of the State. There seemed, however, to be no commanding mind in the State, apart from those holding satisfactory positions under either the State or federal government, all of whom were, of course, contented to let things alone that were well enough for them, to embody into argumentative form the popular impulses upon this subject; and were consequently bold or rash enough to prepare the way for an organized sympathy with the popular agitation elsewhere, in support of a new organization of the old democratic war party of 1812, to battle for the hero of New Orleans, as a leader in the presidential election of 1828.

The active and discriminating mind of Mr. Smith, could not but abhor this apathy. He early conceived, therefore, the laborious project of giving organization to the dissatisfied impulses of the popular mind, to which we have alluded, and to revolutionize the political relations of men in the State. He believed it was in this way only, amid the agitations which began to move the Congress of the United States in both Houses, that Maine could be felt in the Union, and command the respect of others, and the influence that belonged to her as an integral member of the Union. He accordingly conceived the plan of embodying the considerations that tended to such a result, in a series of articles for publication. And he at once set about the execution of this purpose. "solitary and alone." They were upon the amalgamation of political parties, and appeared in the leading paper of democratic antecedents in the State—the *Eastern Argus*, published in Portland, then the seat of State government, and the germinal source of State politics.

These papers were anonymous, and for some time the author was unknown to even the publisher or conductors of the paper. They, however, had a vigor and fire sufficiently unusual to early attract public notoriety, and were read and copied extensively through the State. As an evidence of their estimated ability, they brought down no small amount of personal criticism from other sources, upon several successively, of the leading and ablest public men in the State, who were alone supposed capable of their authorship.

But Mr. Smith's authorship was at length traced by the publisher of the *Argus*, who at once sought an interview, and earnestly invited him to continue his contributions to the paper. After several interviews, he consented to do so, on condition he should be permitted in another series



of articles, to gradually approximate to an open advocacy of General Jackson for the Presidency.

This second series was in due time commenced, under the title of HICKORY No. 1, and with the motto, "*Strike, but hear me!*"

From the fact, that the active political and officeholding men in this State, and the masses also, had been, and were still the supporters of Mr. Adams, after the withdrawal of Mr. Crawford from the canvass, it can easily be conceived, that the title chosen by Mr. Smith for this series of articles, was indicative of a revolutionary movement in politics, while the motto bespoke a consciousness of presumption, but fortified by the right.

These articles began far back in the history of parties, and of opinions and men connected with the federal government, and approached slowly and temperately to the intended issues. Being written with studied candor, yet with pointed energy and decision, they soon awakened the listless, and startled the timid among politicians, both in and out of the State. They were copied far and wide, entire or in portions, in many of the States, and acquired a circulation more extended than any other articles written during that memorable political canvass of Jackson against the Adams administration. And this fact testifies to the influence they exerted upon the public mind of the Nation.

As a necessary consequence, these articles shortly began to draw down upon the author, especially in Maine, a full share of commendations on one side, and condemnations on the other, leading him deeper and deeper into the wranglings of the party organizations that were generated. He soon became, by other arrangements, but without any pecuniary compensation whatever, the principal editor of the *Argus*, and through that paper imparted the tone and energy of his own mind and preferences to all who had either democratic or Jackson proclivities in the State. As an inevitable consequence, he made many strong and chivalrous friends, and correspondingly determined opponents. He had nothing of the craven spirit in him, toward either supporters or opponents.

What marked historically and with emphasis the extent and energy of Mr. Smith's labors at this period, while yet so young and inexperienced, was the fact, that the county of Cumberland, which had been the stronghold of Mr. Adams in the State, from the withdrawal of Mr. Crawford, up to the hour when Mr. Smith unmasked the *Eastern Argus* in support of General Jackson's election, was the only district in New England which at the ensuing election in 1828 gave General Jackson a majority, and elected the only elector from whom he received a vote in the electoral colleges, north and east of New York! This gave this District the distinguishing *sobriquet* among politicians, of THE STAR IN THE EAST! All concurred in awarding to Mr. Smith pre-eminent credit for this result.

The biography of Mr. Smith, from the year 1828 to 1840, enters so largely into the political history of the State of Maine, that to do justice to the one it is quite indispensable to go into the other—which would extend far beyond the limits contemplated by the present notice. We must content ourselves, therefore, with the remark, that in 1828 he wrote a very triumphant pamphlet, entitled "*Vindication of the Land Agent and Refutation of Anonymous Remarks; addressed to the Governor, Council, and Legislature of the State of Maine. By Honestus.*"

This was published in pamphlet, and was successful in protecting the land agent of the State against a powerful and influential essay for his displacement from office.

In 1830 he wrote "*A History of the Proceedings and Extraordinary Measures of the Legislature of Maine, for the year 1830,*" which was at the time conceded to have secured the triumph of the Democratic party

of the State, at the then next ensuing election, and possessed them of a power which they successfully held until the memorable year of 1840, when Mr. Smith separated from their organization, and confessedly contributed far more potently than any other man in the State toward carrying the State for the first time against that party. He introduced "stump speeches" into the State at that time, opening the campaign in an interior town on the 4th of July of that year.

In September, 1830, Mr. Smith was elected one of the representatives of Portland, to the Legislature, on the democratic ticket—the first successful contest of that party since its reorganization in the State. In 1832 he was elected on the democratic ticket a senator to the Legislature from Cumberland District, and by that body was elected president, although many years the junior of all the members at that board. His conceded talents and early political advancement gave countenance to the imputation by his opponents, of a vaulting ambition for preferment on his part. But so far from this being his characteristic then, or since, I learn that after having been nominated in caucus for the presidency of the State Senate, he declined accepting the proffered distinction, that a colleague very much his senior in years might be selected for the position; and retired from the meeting to give greater freedom to the discussion. On returning, however, he found himself again selected with entire unanimity, when he acceded to the request, and his selection was accordingly confirmed by the official election of the Senate on the following day. He served the term with the fullest approbation of senators of both political parties, whose expression at the close of the session was full, cordial, and gratifying to that effect.

On the ensuing election, in 1833, Mr. Smith was elected from the Cumberland Congressional District, member of the 25th Congress, and was twice re-elected, serving through the consecutive years from December 1833, to the 4th of March, 1839. On entering Congress, he again found himself the youngest of his associates. His influence and appreciation in the House is traceable through the different standing and special committees to which he was appointed—being successively on the Committee on Naval Affairs, the Committee of Ways and Means, and Chairman of the Committee on Commerce. He was a leading member of the special committee appointed by order of the House in 1836 on the West Point Academy, and was the author of the report of that committee, although it was submitted by its chairman. He was a member of the memorable committee which visited New York city on the *Swartwout* defalcations and wrote the majority report of that committee, after the points to be elaborated were determined. And I have heard it remarked by a member of that committee, as an evidence of the facility and dispatch with which Mr. Smith wields the argumentative pen, that the labors of the committee were unavoidably protracted until the very close of the session of Congress, by reason of the voluminous nature of the testimony, so that the majority report had been only in part prepared when the final meeting of the committee to dispose of the subject must be holden, and the reading of the report commenced. The reading consequently was so close upon the writing of the report, that two members of the committee were busy in receiving and conveying from Mr. Smith's lodgings to the committee-room, alternate parcels of the report as fast as produced from Mr. Smith's pen, so that no hiatus was had in the reading until completed. It was in this rapid manner that he produced a large portion of the committee's report upon the huge mass of testimony they had taken, and as it now stands in the printed volume of the House, and with no other revision.

Passing over numerous incidents in the congressional life of Mr. Smith,

which would help to elucidate the vigor of his intellect and his energy of character, I recur to the session of 1838-'39 as the period of peculiar interest in the history of the American Electro-Magnetic Telegraph.

It was at that session that Mr. Secretary Woodbury, of the Treasury Department, submitted a letter to Congress, communicating the circular which he had previously issued and disseminated widely, seeking information on the subject of the best modes of telegraphing between distant places. To this call, Prof. Morse forwarded, as did many others theirs, his plan of an *Electro-Magnetic Telegraph*. Mr. Smith was then chairman of the Committee on Commerce in the House of Representatives, and it was to that committee the letter of Mr. Woodbury was referred by the House, carrying with it the various answers which individuals had submitted to him on the subject.

Mr. Morse appeared in person to ask permission of the chairman to be heard by the committee, in explanation of his plan, which was readily granted, together with the use of the committee's room for exhibiting his full-sized telegraphic apparatus, as it had then been matured. The huge hog-trough-looking Cruikshanks voltaic battery, and two immense wheels of insulated copper wire, estimated to be ten miles in length, and a rude arrangement of mercury cups and forked wire levers for breaking and closing the voltaic circuit, and saw-toothed plates of lead, called type, used for breaking and closing the voltaic circuit by imparting to them mechanically a motion forward, under one end of the forked wire lever, and to regulate that breaking and closing, and kindred crudities, all needful for marking the effects of the operation in forms selected to signify the different letters of the alphabet, and through which words and sentences were to be formed for communicating definite intelligence at pleasure, were soon lodged in the committee-room, preparatory to the proposed illustrations by the inventor.

I have heard Mr. Smith remark, that, at the next succeeding meeting of the committee, when these repulsive looking appointments were first seen, a general expression of incredulity characterized the judgment of the members, as to the merits and practicability of the professor's plan. But Mr. Smith had, in the meantime, studied the scientific laws pertaining to the telegraph, and had also acquired a deep sympathy with the professor's story of his travails and poverty, and of his friends' discouragement and apathy on the subject of his invention, and each was such a struggle against odds, that the story was calculated to incite the mind of Mr. Smith to render every aid in his power to advance the inventor's experiment. Had it been an enterprise full of light, and easily understood and readily aided by everybody, the natural inclination of Mr. Smith's judgment is such, that he would have probably at once said, Let everybody give their help, and that his own was not required. However, the hidden power of the crudely-formed agencies employed by the professor were seen and appreciated by Mr. Smith's searching perceptions, and their sublimities and subtleties seemed to challenge his admiration and aid. He felt the awe of a divinity's wisdom and presence as he contemplated the mysterious writings of this invisible but swift messenger of thought; the same he expressed so happily and correctly in the report which he drafted, and induced all his colleagues in committee to unite with him in attesting by their signatures, contrary to all precedents of Congressional Reports. He explained to his associates on committee, the positive and wonderful truths which the clumsy apparatus before them was capable of demonstrating, and he interested them to pledge a full and punctual attendance at a special meeting, to listen to the explanations, and witness the trembling and half-confident manipulations of the inventor himself. This earnest and voluntary interest on the part of Mr. Smith, in-

spired Professor Morse with a new hope, and a new life, and the prospect of such aid was to him, as the undoubted guaranty of a complete ultimate success.

The time for the appointed exhibition to the full committee arrived. Professor Morse was there with punctuality, and filled with new animation by the continued manifestations of a purpose on the part of the chairman, to render him every possible support, from conviction that the theory of the invention was a reality, and deserving of the liberal patronage of the government in hastening its development practically.

Suffice it to say, the exhibition was convincing and conclusive to the committee, and the chairman obtained the necessary instruction to report in its favor, with an appropriation bill for *thirty thousand dollars*, to construct an experimental line between Washington and Baltimore cities. Mr. Smith proceeded at once to draft the report and bill—the same report which has been given elsewhere in this volume. It was unanimously approved and signed by the committee, and this dawning of a future so much brighter than all previous encouragements had opened up to him, so electrified Professor Morse, that, had Congress never acted further upon the subject, he would still feel that he had not lived in vain.

It was this report that gave vitality, “habitation, and a name,” to the Morse Telegraph. Its language spoke in the tones of a positive conviction of the reality of the invention, and of the diversity of its powers, and the grateful inventor owned then, that he had been providentially guided to a friendship in the zeal of Mr. Smith, such as he had most wished for, but had never before attained among his fellow-men. And, he insisted on having the author of this report accompany him to Europe and to stand by his side through all the coming struggles for the inauguration into practical use by the world, of this new and wonderful agent of intercourse. It was thus, and then, that Professor Morse proffered Mr. Smith the ownership of one fourth of the entire invention in the United States, and five sixteenths of all its advantages and the interests that might be acquired under it abroad, he furnishing the requisite means of outfit for the visit to Europe together, to prosecute its adoption there by the public. Mr. Smith, filled with admiration of the invention, crude as it was then in form, accepted of these proposals; and in May following, (1838) he having obtained leave of absence from the House for the remainder of the session, embarked with Professor Morse at New York for Liverpool. Having arrived in London, they immediately set at work reviewing the outposts of inventions on foot there in the same line—visited Mr. Davy’s Electric Telegraph, then on exhibition, also the Patent Office, and believing the way clear to the procurement of a patent for the professor’s invention, submitted the application in due form. To their astonishment, notice shortly was received of its disallowance by the Attorney-General: upon what precise grounds was not explained, so as to subject the opposition to a full and open contest. But upon the fullest insight that could be had, at the request of Professor Morse, Mr. Smith framed a concise argumentative letter addressed to the Attorney General, which was copied and signed by Professor Morse, in which a farther hearing was sought, and was finally obtained; but with no more success than before. This letter, while it successfully refuted every objection, as is still believed, to the just claims of Professor Morse to a patent from the English government for *the mode* of operating an Electro Magnetic Telegraph which he had invented, without claiming all modes, presents also the exact sum of perfection to which the professor’s invention had reached at that period; and for this purpose it is the best historical exposé of the subject which exists, for substantiating the claims of the professor to inventive genius in practical telegraphing.

With this unsuccessful result upon them in London, Mr. Smith next accompanied Professor Morse to Paris (July 1838), where an original, and subsequently an additional patent was obtained. But the French government, jealous of this mystical agency, subsequently interposed a prohibition to the establishment of it under the patents, so that they expired before made available to the proprietors. As an act of justice, the government of France has recently interposed to raise, conjunctively with some other of the continental governments in use of the system, a donation of \$80,000 in acknowledgment of the great merits and utility of the Morse system over all others—a tardy, but merited compliment.

While in Paris, as early as October, 1838, Mr. Smith brought out an article in the *Observer*, published by Galignani, containing the *first idea ever* announced of the uses that were destined to be made of the telegraph for astronomical purposes. Even Professor Morse did not then fully comprehend this important element of its ultimate utility. In fact none at that early day appeared to measure the immense scope which the invention had in the future uses of the world with the same clearness as did Mr. Smith. His early report to Congress and his contemporaneous writings attest fully this fact. Mr. Smith embarked at Liverpool for the United States, in November, 1838, in the illy-provided steamer *Liverpool*—the newest of the ocean steamers put into service by the first ocean steam company. An almost unprecedented storm set in on the same night, which continued without intermission until the morning of the sixth day, when the ship had become so disabled, having been swept fore and aft by the sea of everything on deck, including most of her boats, and been in the most perilous condition for many hours, was then put about and run with the storm into Ireland, where she arrived on the morning of the 9th day from Liverpool. The passengers were landed at Cork, and Mr. Smith with most of them returned to Liverpool and re-embarked in one of the regular line sailing packets for New-York, where he arrived the latter part of December, too late to resume his position as Chairman of the Committee on Commerce in the House. Mr. Morse, remained in the meantime and until the following spring in Paris to foster the interests of the infant telegraph, with alternate hope and despair of success. Flattering expressions in the fulness of French coquetry were showered upon its, to the multitude, inscrutable performances, but nothing more substantial resulted to the proprietors.

The session of 1838-'39 of Congress terminated without reaching the Telegraph Bill on the calendar for action; and Mr. Smith's acquired interest in the enterprise forbid his moving the subject out of its order. His split, moreover, from the dominant administrative party on the Sub-treasury Bill, deprived him of his accustomed influence with the majority party on any measure, and he preferred biding his time out of Congress with the Telegraph, to any injudicious crowding of it in Congress against well-measured probabilities.

He retired from Congress at the close of the session; and in the following year entered with heroic zeal upon the determined purpose of overthrowing the power of the Van Buren Administration in Maine, and wherever else it might be favorable. It was in appearance not only a Herculean but a forlorn task, in a State so thoroughly drilled and solidified under party organization as Maine then was. But Mr. Smith had been part and parcel of that organization too long—had aided too largely from its inception, to give it consistency and strength—not to understand all its elements and workings, and ins and outs to popular feeling, to be wasting power in blind assaults upon battlements which he knew had become hollow, enfeebled, and destructible at certain points; and it was at these he made and led on the rush of the opposition forces. Federal

and State patronage did their utmost to crush him out. He established, at his own expense, a semi-weekly paper in the city of Portland, entitled the "Argus Revived"—opened the campaign in full blast for the nomination and election of General Harrison against Mr. Van Buren—took the stump at the first formal stump meeting ever called in the State, held on the 4th of July, 1840, in an interior town of his old congressional district, and made a clear and decided success of the meeting for the opposition forces, and inspired doubting and timid minds with confidence to follow, and opened up a sense of alarm in the ranks of the administration party which could not be suppressed. As a public speaker he had no superior in the State; and his fervid eloquence, and his long and intimate acquaintance with the whole people of Maine, through their politics, enabled him to draw multitudes at the meetings he appointed, which no one else could command.

In conclusion I need only remark, that at the gubernatorial election of that year, to everybody's surprise, an overwhelming administration majority was annihilated, so it was in doubt whether any election of governor had been made by the people; and at the succeeding November presidential election, the State was carried by a small majority for Harrison and Tyler.

It was everywhere and by everybody freely conceded, that this result in the State, was accomplished by the indomitable energy, labor, tact and eloquence before the people, of Mr. Smith. It was an unparalleled revolution that was effected in September; and it had a most signal influence for hope and courage upon the supporters of General Harrison in every other State. But the revolt in November was complete, and the one man power in it was indisputable. For this sore defeat the democratic leaders of Maine never forgave Mr. Smith, and he was not of stuff to ask forgiveness where he conscientiously believed himself in the right, although the world were in arms against him. His self reliance has ever been a remarkable characteristic of his life, and equalled only by the cool, self command which, under all circumstances, he succeeds in maintaining, and as few men are capable of doing, and none but men of marked intellectual strength. I have heard it remarked, that one of the chiefest characteristics of General Jackson was, a skillful knowledge of "the exactly right time to get mad," or at least, to appear so, to exert the greatest effort upon an adversary. It is doubtless a species of mental strategy worthy the study of all men in all the relations of life. A cool, imperturbable temper, carries most potent advantages to its possessor over all others.

It was at the session of 1843-'44 that Professor Morse succeeded in getting favorable action by Congress upon the original thirty thousand dollar appropriation reported by Mr. Smith, and thus enabled the proprietors to construct the first experimental line of telegraph in the United States. It was in the expenditure of this appropriation, involving previously untried plans that gave rise to some differences of views between Professor Morse and Mr. Smith, which led to a reciprocal coldness and distrust which has never been subsequently removed; and which under varying aspects of personal interests, operated powerfully to retard the progress and productiveness to the proprietors, of the invention in the United States. I do not propose to enter into a discussion of these matters here, as it would be out of place to do so, and the time for an impartial judgment on the subject of these personal differences, which all friends to the parties deeply regret, has not perhaps arrived.

In 1844-'45 Mr. Smith enlisted a few friends, and labored to enlist the public generally, in raising the necessary funds for extending the telegraph from New-York city to Boston, and thence to Portland. He gave one or

more public lectures upon the interesting characteristics and destined influences of the system, which all were pleased in listening to, but few had faith to hazard their money in putting them into practical use. The consequence was, he added all of his own then limited means to so much as a few friends and a few citizens of intermediate towns would risk, and at length succeeded in completing the first line between New York and Boston. This line he subsequently extended to the city of Portland, at his own cost exclusively. From Portland east, the successful working of previously constructed lines, operated to encourage others to invest in, and he, with less difficulty, through private partners, obtained the needful capital for building as far the eastern boundary of New Brunswick.

But few can appreciate the struggles and delays which the early projectors of this now important institution had to encounter in getting it before, and into the use of, the public. Men who saw with their own eyes the telegraph in actual operation, would turn round and yield themselves up to doubts of its reality—still suspected, there was some undefined and unseen devilry about it, that made it unsafe as an investment.

From 1838 until the present time, Mr. Smith has continued prominently engaged in the organization and working of the system, laying its details aside now and then for a season, to indulge his tastes and preferences in the politics of a presidential election, but returning speedily to his general supervision of the business, in conjunction with the Hon. Amos Kendall, as the representative of the other patentees.

In the meantime, Mr. Smith has displayed the diversity of his powers and genius in his profession as a lawyer, attaining instances of as startling success to his adversaries, as have at different junctures marked his labors in politics. By far the largest verdict ever obtained in his State, and I think the largest obtained in New England, was won and held by him for a client through seven years or more of sharply conducted litigation, in a railroad suit that had become famous in Maine. In the meantime, however, he became the sole owner of another active railroad, of some thirteen miles in length, and extended it, with his own capital, some six miles further into the interior; also constructed mills in another region, and a steamboat for inland navigation, and within a year or two has become principal proprietor and manager of a canal commanding some fifty miles of inland navigation from the harbor of Portland; he also constructed, mainly in the first instance with his own capital, the public gas works in the city of Portland, amidst great but unsuccessful opposition; and concurrently with these diversified cares and labors, he has been so mindful of the pleasures and comforts of a home, as to construct and support one of the most finished architectural dwellings and little village of out-buildings that any man of moderate ambition could desire. For this he selected a site where a forest of ancient oak and of evergreen trees admitted of utter seclusion from the world, although within two miles from the city of Portland, and where for twenty years he has been accumulating a library that is second to none of a private character in the State; and, unlike the purposes of many such accumulations, more for actual use in the varied pursuits of the owner, than for show to others.

Elaborate as has been this notice of Mr. Smith, as due to the primary founder of the now extended telegraph system of the United States, I claim for it but the merit of a limited outline of his "battle of life," evincing a diversity of talent, and an energy of character, and a steadfastness of purpose when once formed, rarely equalled, and perhaps never surpassed as a whole, by any man. Of course, such a man cannot have been without earnest opponents, more than devoted friends. But whether in friendship or otherwise, his acts, as all men accord, have been uniformly

open, manly, consistent, and resolute. To have been always in the right, would be more than fallible man can claim; nor probably can it be claimed for Mr. Smith. But the claim of right motives at all times on his part, is best attested by the fact, that the most determined of his enemies have invariably become in time, and on better acquaintance, his fast friends; and I know not the man in this time who can count among those disposed to praise him for his attainments, qualifications, and integrity of purpose, so many who, under other views and less intimate acquaintance with him, were either strongly prejudiced or openly hostile to him.

He is comparatively yet a man of only matured years, of vigorous health, of careful habits, and untiring industry. And with these characteristics I need not doubt, but sincerely hope, he is yet to make new works of usefulness to mankind, as well as of advantage to himself and family.

He has been twice honorably connected by marriage, and has offspring surviving by his first, as well as second marriage. Of these the future will speak honorably, if kindness and devotion as a parent and husband can on his part merit that gratification.



## WILLIAM M. SWAIN,

Of Pennsylvania.

THE subject of this brief sketch was born in 1809, in Manlius, Onondaga county, New-York. It was but a few years after the birth of Mr. Swain that the last war with Great Britain took place, and his father was among the brave patriots of that day, who at once left their comfortable and well-supplied homes to take part in that struggle for their country's honor. While in the performance of his duties as a soldier, Mr. Swain's father caught a very severe cold, and was brought home. He died from its effects, leaving his son William but three years old. Fortunately for Mr. Swain, his mother was an uncommon woman of that day. She was well educated, and possessed the ability and experience necessary for the proper management of domestic affairs. In his earlier years Mr. Swain received a liberal education, and his clear and discriminating judgment of the present time was manifested then. He studied his Euclid with assiduity and the most complete success, and the evidences he gave of a well-cultivated mind in after-years induced his friends to urge him to give to the young the benefits of his richly stored mind by opening a school. He was thus employed for several years, but the life of a teacher did not harmonize with his tastes, and he abandoned it. In 1825, he selected the art of printing as the most congenial to his disposition as an affair for life, and in due time he was found standing at the case. The superior talents of Mr. Swain could not be confined, however, to the labors of the compositor, and a greater range for the exercise of his thought was necessary. In a few years thereafter he occupied a position in the establishment which gave him an opportunity to exhibit his singularly well matured administrative powers.

His abilities seemed to be diversified and capable of commanding the whole routine of a publishing establishment, and the evidences given secured for him the charge of the New-York Sun. As an editor he was talented and vigorous. As manager of its business affairs he had no equal. He toiled day and night in the discharge of his duties. The dawning of day often found Mr. Swain at work, having passed the whole night in the service of the establishment. He discharged his business first, and his personal comforts were the last matters that he cared for.

In 1837, Mr. Swain, in company with two others, Messrs. Abel and Simmons, started the "Public Ledger" in Philadelphia, and subsequently the "Sun" in Baltimore. These were "penny papers," and were opportune for the laboring classes of the country. In establishing these papers the gentlemen were not adventurers, without means, abilities, and experience. Mr. Swain had become a perfect master of the publishing business, and, as well as his partners, brought into the company his proportion of capital. The "Ledger" was thus introduced to the world for patronage; it was founded with ample means by gentlemen energetic and talented.

\*The Ledger was not long an experiment, but it soon commanded the confidence of the public and the most extended patronage. It still continues to wield an influence unsurpassed by any other paper.

I much regret the impossibility to do justice to the career of Mr. Swain in this outline. His life has been full of usefulness, and his example is worthy of imitation.

In the administration of the affairs of the "Ledger" Mr. Swain never yielded the responsibility. He was known as the "Ledger man," and he was the master of the enterprise in every particular. He always exercised the right of determining what was suitable for publication, and no one has ever had the authority to publish in the columns of that paper a line, editorial or otherwise, except by his sanction, implied or expressed. Mr. Swain was the "Ledger man" and he was alone responsible for the contents of that paper. It has been owing to this fact that the tone and tenor of the "Ledger" has been so uniform and judicious.

Mr. Swain has been, on all occasions, a liberal patron of new and useful enterprises. When the electric telegraph had given proof of its commercial utility, on the experimental line between Baltimore and Washington, he was among the first to appreciate its merits. In due time efforts were made to extend the line to Philadelphia, and in order to command the necessary capital, each of the cities through which the line was to pass, was allotted a certain proportion of the stock. To Philadelphia was given four thousand dollars. Mr. Swain was urged to promote the enterprise among his friends. Their efforts in obtaining the capital required at that city were crowned with success, though that success was due entirely to the "Ledger," and the "United States Gazette," the former subscribing three thousand five hundred dollars, and the latter five hundred dollars. Commercial men could not be induced to embark in the new and to them untried enterprise. They did not appreciate the prospective usefulness of the telegraph. With Mr. Swain it was no adventure, because his comprehensive mind and practical sagacity enabled him to look into the future. History has since demonstrated the correctness of the judgment he exhibited, in the extraordinary and most liberal subscription above given.

Early in 1846, Mr. Swain was elected a director of the Telegraph Company, and he gave to the new enterprise the benefit of his commercial experience. He fully appreciates the grandeur of the invention, and of its transcendent position as an art; but, as in all other things, Mr. Swain has studied it as an element of commerce, as an art for the useful purposes of man; and no one has done more toward perfecting the telegraph for business relations than he. The influence of his teachings has spread throughout the whole country.

In 1850, Mr. Swain was elected President of the Magnetic Telegraph Company, extending from New-York to Washington. He sought not the position, but the friends of the enterprise desired his experienced and well-methodized mind in the perfection of the system. The telegraph was new, it had not established itself in the affairs of trade, and it required an organization commensurate with the wants of the age. Mr. Swain yielded to the wishes of his friends, and accepted of the presidency, though it was to him a great pecuniary sacrifice. He contemplated limiting his services to a single term. He entered upon the duties of the office, with his usual resolve, to be the master of his vocation. He travelled over the line, and reviewed its whole structure, and aided in the perfection of its outdoor organization. In this new and novel labor he shared with others, and soon became as thorough in his knowledge of the construction of the lines, as though he had taken part in its original erection. Having become fully informed as to the exterior department of the service, he next gave his attention to the administration of the stations. He soon found opportunities to present improvements, and as the science and art of telegraphing became more and more developed, Mr. Swain was prepared to

meet any emergency, with a commercial talent that was productive of good results.

Contrary to his wishes, Mr. Swain was induced, by the unanimous desire of the company, to continue as president until 1858, when he felt constrained to terminate his services as its executive.

Mr. Swain continues as a director of the old pioneer telegraph company, for which he has done so much as its founder and constant patron. He has, also, extended liberal aid to other companies, pecuniarily and intellectually.

Among the changes made by Mr. Swain, in the management of the stations, may be mentioned, the more prompt delivery of dispatches. It was the former practice for the manager of the station, to send out his messengers every hour, or at such times as an accumulation of dispatches would require. Mr. Swain discovered that messages were received from places, a thousand miles distant, in less time than was required to deliver them a few squares from the station. This delay seemed to him out of proportion, and contrary to the very spirit of telegraphing. He directed that the messengers be increased, and that as soon as a dispatch was received, it should be delivered. This change in the delivery, was as effective as a revolution in the art of telegraphing, and the benefits resulting were at once observable, by the increase of dispatches, and of the revenues of the company. The same rule was soon after adopted by all the other companies throughout America, and it has been productive of the best results.

Besides Mr. Swain's transcendent powers as a business man, he is one of the most liberal, enterprising, and benevolent men of the age. He has distributed his gains in thousands of ways, that neither he nor any one else can ever account for. What he has done, has been without display—without heralding it to the world. His charities stand unrecorded in the annals written by man, but they are engraven on golden tablets by One whose ken fathoms the "innermost recesses of the heart."

## WILLIAM TANNER,

of Alabama.

MR. TANNER was born in Montgomery county, Kentucky, in 1802, and is, consequently, fifty-seven years of age, though he does not look so old by several years. When a boy not fifteen years of age, having as good an education as the schools near him, at that time, could afford, he was placed in the printing office of the *Argus of Western America*, a newspaper published at Frankfort, Kentucky, and edited by the Hon. Amos Kendall, then a young man, where he learned the printing business. Mr. Kendall was then the public printer of the State, and his paper the leading Republican journal of the West, which, doubtless, had its influence in making the subject of this sketch a firm democratic politician all his after-life. It is worthy of mention here, and alike creditable to both parties, that from the time Mr. Kendall was a young man and Mr. Tanner a boy, they have continued to be warm and confidential personal friends, now more than forty years, and much of the time in some way associated in the same pursuits.

From a respectably educated printer the transition to an editor was almost a matter of course, and as early as 1823, Mr. Tanner entered upon the life of an editor and publisher, before he was quite of legal age, and so continued, with occasional intermissions, until 1854. At that time he was the oldest editor, in point of time, in Kentucky. He published the *Western Monitor*, at Lexington, the first semi-weekly paper printed in the State, next the *Morning Post*, at Louisville, the first daily paper, and in 1843 he started the first daily paper published at Frankfort, the capital of the State. During several years of the time he was sole editor and publisher of the *Kentucky Yeoman*, the present State journal at Frankfort; it was unquestionably the organ of the democracy of that State, and, besides the influence it exercised in national politics, it wielded an influence over many questions of local and State policy, the defeat or success of which have left their impress upon the permanent destinies of his native State. I may mention, as the leading measure of this kind, of which he was the earliest, most persistent, and devoted advocate, the adoption of the present Democratic Constitution of the State. In 1845-'6, he found the State government not only in the hands of his political opponents, as it had been for a long series of years, but nearly all of the public offices of every description were in possession of persons who had either inherited them from generation to generation, or who had purchased them in open market for a stipulated price, to be paid in hand or out of the annual profits arising from abuses of the office. Through his own paper, the *Kentucky Yeoman*, and another paper which he caused to be established and published, almost entirely at his own expense, devoted to that particular subject, he not only exposed the venality of the official corps of the State, but made such appeals to the pride and patriotism of our chivalrous people, that he soon had enlisted in the cause the leading men of both parties, and upon the submission of the question to the people by the Legislature, they voted for a new convention with almost unexampled unanimity. The result was, that in 1849 delegates were chosen by the people from the best men of the State to form a new con-

stitution, and, to the surprise of the whole country, a majority of them were democrats. The Legislature, which had provided in advance for defraying the expenses of the convention, appointed Mr. Tanner and a gentleman of opposite political views, to provide for having the debates of the delegates to the convention reported, and the convention, when it assembled, appointed him and the same gentleman the printers and publishers of their proceedings and debates, all of which services were faithfully performed. The liberal constitution which at the present time controls the destinies of the proud State of Kentucky, contains but few leading provisions not recommended to the people and advocated by Mr. Tanner before the delegates met in convention. The feature which requires the election by the people of all public officers he insisted on with more vehemence than any other, and, for a time, in opposition to the wishes of some of his own political friends. \*The election of the judges was particularly objectionable to many of the new convention lawyers.

I have referred to this particular period in the life of the subject of this sketch, so much in detail, because I know he takes more pride in the acknowledged influence which he exercised on the occasion than in any other of his political achievements.

A few years before the success of Mr. Tanner and his friends, on the question of the constitutional convention, I was his senate reporter in Legislature of Kentucky, and I well remember his unceasing efforts in behalf of that important political measure, and I know, from personal observation, that Mr. Tanner then enjoyed, as he had done for many previous sessions, a large share of the confidence of men of all parties in the Legislature, and that he oftener exerted his influence with the members to secure the success of measures for the benefit of the State and his friends than to promote his personal interests. But that course has been one of the chief characteristics of his life.

In 1837, after about twenty years' service in a printing office in one capacity or another, Mr. Tanner went to Washington City, where he served for about two years as a corresponding clerk in the Postoffice Department, under his old friend and editorial preceptor, Mr. Kendall, who was then Postmaster-General. There, in the following year, he married Miss Orme, his present amiable wife. The subordinate position and dull routine of a clerk's life were not agreeable to his active mind and sanguine temperament, and he has often told me he could not fall into the sluggish ways then, and perhaps yet, so prevalent in the public offices at Washington. To relieve himself from the mental tedium and bodily inertness consequent upon his dull public duties, he not only became the regular Washington correspondent of several distant newspapers, but took the principal charge, privately, of an independent daily democratic paper called the *Metropolis*, where he enjoyed himself by keeping members of Congress of both parties, and other official personages, uneasy in their high places. The paper, while he controlled it, enjoyed much popularity in subordinate official circles, and received a good deal of attention from some high functionaries. It was much in favor of the Canada patriots during the so-called rebellion of 1837-'8, and Mr. Tanner received the personal thanks of Passenue, one of the McKenzies, Wolford, and others of the leaders of that movement, for his advocacy of their cause.

Becoming tired of Washington he was offered a more congenial business because it gave more active employment, and was made one of the four Special Mail Agents which the Postoffice Department then employed for the whole United States. With a good salary for that time, and freed from official surveillance and subordination, with the enjoyments incident to constant travel over a large portion of the Union, this was an employ-

ment not only agreeable to the taste, but suited to his peculiar capacity, and consequently he continued to serve the department in that office until the political wheel of fortune changed the national administration.

Twice afterward, however, Mr. Tanner received commissions as special agent. As an evidence of the confidence then reposed in him, at Washington, it may be stated that he was sent to Wisconsin and Iowa under special appointment, when those present States were still territories, to collect large sums of public money, without being required to enter into any sort of bond, or to give any security. He filled the delicate duty thus intrusted to him, so much to the satisfaction of the department, that his return and account were received without the detection of an error or the change of a figure, and called from the Auditor, Peter G. Washington, Esq., a letter of thanks.

Soon after, in 1846, Mr. Tanner was sent by the Postoffice Department, to Texas, to arrange the mail service of that new State, after its annexation to our constellation, and to bring that service under our government. There, for nearly six months he travelled over most of the then settled parts of the State, making postmasters, establishing post-offices, collecting money from postmasters, letting out mail contracts, and doing everything in his own person which belonged to the several bureaux in the Department, and finally making out the first advertisement calling for proposals for mail service, which also furnished material for the first post-route bill passed by Congress for the State of Texas, a bill which was afterward very much in the way of some politicians who voted for it, for it denied them the privilege of asserting the claim of Mexico over the territory between the Rio Grande and the Nueces. This duty performed, during which the correspondence to his paper gave a view of Texas theretofore unknown in "the States," Mr. Tanner continued to hold the commission of special agent, performing the duties required, and to publish his paper in Frankfort until the autumn of 1847, when he resigned his commission for the purpose of again joining his old friend, Mr. Kendall, in the then almost untried telegraph experiment.

And here commences the only legitimate part of Mr. Tanner's career in life, which it is the province of this work particularly to chronicle, except as collateral, to show what kind of persons it was who originally took hold of an enterprise then of doubtful success, but which is now exercising so vast an influence over the social, commercial, and political destinies of the world. But aside from this reason, I give as another, that as an associate in this great enterprise, it is to me a source of great pleasure to acknowledge Mr. Tanner, now as during nearly twenty years past, my steadfast friend, and whose superior years and more matured judgment, I never failed to respect. And in giving this brief biographical sketch of one of my earliest friends as well as one of the earliest adventurers in the great field of telegraphic enterprise, I but discharge a duty I owe to myself, to Mr. Tanner, and to my countrymen, who have chosen the pursuits of telegraphy as the vocation of their lives.

In the fall of 1847, Mr. Tanner and myself became joint contractors for building the first section of two hundred and seventy-five or eighty miles of the present "National Line," from Lexington, Kentucky, to Nashville, Tennessee, the first telegraph line constructed south of the Ohio river. We finished that section in three and a half months from the time the first post was cut in the forest. The wire then put up, and many of the posts are those now standing, and in use on that line. Afterward Mr. Tanner was successively secretary, treasurer, president, and superintendent of the whole line, from Pittsburg to New-Orleans, part of the time before the line was completed, having no one to aid him in any of those capacities. He yet holds the nominal position of president

of the old New-Orleans and Ohio Company, the stockholders in which, or their successors, will be the owners of the "National Line" at the expiration of the present lease. Like most others of the Western Companies, the fortunes of this one were disastrous. And like most of the great improvements of the age in this country, it is probable the pioneers, those liberal-minded and free-handed men whose money constructed, and whose energies pushed it to the paying point, are not destined to reap the rewards due to their enterprise. It is not an exceptional case for any one company to be placed in this category, as the history of two thirds of the great enterprises of the age, on this side of the Atlantic, will show that it has been the fortunate second or third owners of such property who have secured the profits which in the ordinary course of events, should have been due to those who first inaugurated and carried *nearly* to a successful completion, the greatest improvements of the time.

Mr. Tanner, yet in the vigor of life and health, is now engaged in the telegraph service as a local superintendent of the Magnetic Telegraph Company's great Southern line, and the present success of that company South, as elsewhere, is testimony in favor of his efficiency in the discharge of his duties.

Of this world's goods, after a life of more than usual industry and toil, devoted to useful and meritorious pursuits, Mr. Tanner may not have a superabundance; but in the affections of an estimable wife, and several charming, intelligent children, he is as rich as the Roman matron, who so proudly pointed to her jewels; and, with a respectable income and moderate desires, we are pleased to learn he lives contented, in the enjoyment of all the comforts essential to a united and happy family, in a comfortable home in the "sunny South."

## JOHN JAMES SPEED, JR.,

of Michigan.

On the 20th of July, 1803, in Mecklenburg County, Virginia, was born the subject of this brief memoir.

His parents belonged to a very old family of that ancient Commonwealth; and were known as high-toned in sentiment and of the old patriotic school.

With a view of expanding his means for the best ends, Mr. Speed's father emigrated from the thickly inhabited Old Dominion in the year 1807, to the more sparsely settled county of Tompkins, in the State of New-York, where he had full opportunities to develop his wealth and enterprise.

In the education of the son, the father devoted all the attention possible, and every opportunity was afforded him common to that time.

Having arrived at his majority, he commenced his career in the world as a merchant, but he soon returned to the more genial pursuits of his earlier years, and fixed himself upon one of the largest farms in that part of New-York, containing some 950 acres, of which he cleared 700 acres for cultivation. He continued in the tilling of the soil until the year 1836, when he sold his farm and stock for the very respectable sum of \$26,000, which amount, in that day, as well as the present, was amply sufficient to afford a moderate disposition all the comforts and luxuries enjoyed by the millionaire of the Old World.

In 1836, Mr. Speed established himself as a merchant at Ithaca, New-York, where he continued for some ten years. In the meantime, however, he liberally embarked with other citizens in all the enterprises calculated to promote the welfare of the city and the respective individuals engaging their services and capital. Among the most noted branches of industry to which Mr. Speed gave much of his energy and means, was a woollen manufactory, at that time one of the most extensive in America.

In 1846, Mr. Speed commenced his career as an active telegrapher, and to this day his mind and energies are directed in the same pursuits. In 1847, he removed to Detroit, Michigan, as a more central place in the network of telegraph lines with which he was connected.

In domestic affairs Mr. Speed has been fortunate and singularly blessed. He married an estimable daughter of Mr. Charles Morrell, in 1829, and at the present time his fireside is ornamented with the bright smiles of eight intelligent and affectionate children.

Though not an ambitious man, Mr. Speed has made his mark as a politician. In 1832 he was elected to the Legislature of New-York, from the county of Tompkins, and in 1840 he was the presidential elector of the then great Whig party, whose signal triumph in the national government has distinguished the time as an era.

In military affairs Mr. Speed has always taken an active part, having a view to the perfection of the militia system of the country: and he has



passed through many of the official positions, holding a commission from De Witt Clinton.

The purposes of this work do not allow of an extended notice of the many distinguished services rendered by Col. Speed in the advancement of the Arts and Sciences. I will, therefore, more particularly notice his connection with the telegraph, in the service of which he has been recognized as one of the most distinguished.

From 1832 to 1846, Col. Speed made many experiments, having in view the perfection of telegraphing. He was aided by Mr. Charles J. Johnson, of Oswego. Their attention at first was directed to the visual system, and they succeeded in making some very valuable improvements, greatly facilitating the transmission of intelligence by the semaphore. In 1837, they sent their improvements to the Emperor Nicholas of Russia, and in return they received a highly complimentary letter, fully appreciating the invaluable services they had rendered the imperial government.

These gentlemen devised means of communicating intelligence by electricity, but as they did not press their inventions and discoveries to an early fruition, other systems were introduced and became generally accepted—the most distinguished of which was the apparatus invented by Prof. Morse.

In 1846, Col. Speed became associated with Mr. Ezra Cornell, of Ithaca, New-York, in the extension of the Morse telegraph lines, in the northeast and northwest. These gentlemen united their energies and talents in the perfection of the various apparatuses of the system; and to them, perhaps, more than any other two telegraphers, we are indebted for the successful operating of the lines. They invented innumerable simple and useful contrivances, effecting rapidity and convenience in the manipulation of the telegraph.

The united energies of these gentlemen and their conjunctive associates, Messrs. J. H. Wade, S. W. Hotchkiss, Tower Jackson, and others, in a short time erected and successfully operated some five thousand miles of lines, traversing New-York, Ohio, Indiana, Michigan, Wisconsin, and Illinois.

At the present time Col. Speed is associated with Mr. Henry O'Reilly in the extension of the telegraph westward of the Mississippi to the Pacific ocean, traversing the widespread plains of the far West, and the meandering passes of the Rocky Mountains. He is also connected with Mr. Tal. P. Shaffner in the consummation of the telegraph between the eastern and western hemispheres, via Greenland, Iceland, and the Faroe Isles.

Col. Speed continues in the enjoyment of full vigor, good health, and energies as active as the youth of twenty. Through his co-operation the world may confidently expect to see the Atlantic and Pacific oceans united by the lightning cord, and the continents connected by the fiery chain beneath the bosom of the ocean.

## JEPHTHA H. WADE,

of Ohio.

Mr. WADE was born August 11th, 1811, in Seneca county, New-York. At an early day of his life, after having a very fair education, Mr. Wade commenced his career as a mechanic, and his ingenious mind gave many proofs of more than ordinary powers. His perceptive faculties were not only active, penetrating the whole of a subject, but he had a singular power of discriminating between the relative forces of things. These early characteristics gave unmistakable evidences of the power of his mind and his future career in life.

From 1835 to 1846 Mr. Wade assiduously devoted himself to the study of portrait and miniature painting, in which he gained considerable celebrity. I have said he was engaged in the *study* of the art, because the term seems to comport with Mr. Wade's views, as he considered the perfection of the art unattainable, save by Him who gives brilliancy to the sun, and circles the heavens with the rainbow tints.

Mr. Wade entertained the highest appreciation of the beautiful art of painting, but he found it necessary to change his pursuit to one of more activity. In 1846, he abandoned the alluring art, and entered the profession of telegraphing. In this new vocation he had an opportunity of giving his physical energies an activity commensurate with the powers of his mind. He seemed to be singularly fitted for the telegraphic enterprise, and in a short time he distinguished himself as one of the most successful administrators engaged in telegraphic affairs.

Mr. Wade was in telegraphic connection with Col. John J. Speed, Jr., and Mr. Ezra Cornell's lines, and he aided materially those gentlemen in the extension of a large range of telegraphs in the Northwest, extending over New-York, Ohio, Indiana, Michigan, Illinois, and Wisconsin.

Mr. Wade was very successful in getting subscriptions for stock, as every one who knew him had unlimited confidence in his opinions. He constructed the Cleveland, Columbus and Cincinnati line, and the Cincinnati and St. Louis line, and also several branch lines, occupying duplicate routes, for the benefit of his main lines.

In 1854 Messrs. Wade and Speed consolidated their lines with the Western Union Telegraph Company, then operating the House apparatus. By this important union of lines, the great Northwest was brought into a more immediate connection with the city of New-York, a consummation, for many years previous, "devoutly wished."

The new organization secured the invaluable services of Mr. Wade as a general agent, intrusting to his superior skill and negotiating tact, the consolidating other lines into the Western Union Company. The end desired has been accomplished to the full and complete satisfaction of all parties interested, and now the consolidated company has within its jurisdiction the vast range of lines running from the east and northeast to the west and northwest.

Though the field of Mr. Wade's negotiations was not enrobed with the splendor of the careers of Talleyrand, Metternich, or Nesselrode, yet I presume no one will deny but what the diplomatic skill necessary to be

exercised in his pathway was as intricate as any duty ever discharged by those stars of European political diplomacy.

I have enjoyed the acquaintance of Mr. Wade for many years, and the utterance of these truths is but just, and I confidently believe they are in full consonance with the universal opinion entertained of him by others wherever he is known.

Mr. Wade has filled the various positions of the practical telegrapher, and he failed not to comprehend at an early day a thorough knowledge of the whole science and art.

As a result, springing from his untiring energies, and the correct administration of his affairs, he is blessed with this world's goods enough to comfort the remainder of his days and those of his estimable family.

In 1853, I wrote of Mr. Wade as in the annexed paragraph, and in the sentiments and opinions then expressed I now concur, and reiterate with increased confidence in their entire correctness :

“ By his indomitable energy, and punctuality in all his engagements, he has succeeded in securing for himself an ample fortune, and his reputation as a successful and energetic telegraph superintendent, is permanently established. The companies over whose affairs he has been called to preside, have been eminently fortunate in obtaining his services. He manages their interests with wonderful industry and skill, and has secured for them a reputation and prosperity second to none in the country.

He is a capital business man—ready, active, and vigilant—shrewd and penetrating, but honorable, fair, and conciliatory. He is liberal in his arrangements, and commands confidence by punctuality, and a generous disposition to divide the field of labor with others. Possessed of that rare quality known as *tact*, he seldom errs in his arrangements, which are, for the most part, eminently fortunate. As a financier, he is prudent, skilful, and punctilious. The fine points in his character endear him to his friends, and his courtesy and affability have rendered him most acceptable to his agents, by whom he is universally respected, and held in high esteem ; and he has rendered himself peculiarly agreeable to the managers of other lines, whose personal regard and fullest confidence he has won, and which materially contributes to his signal success.”

## LEVI LINCOLN SADLER,

*of Massachusetts,*

LATE Secretary and Treasurer of the New-York and New-England Union Telegraph Company, is the subject of this brief memoir.

Mr. Sadler was one of the remarkable men of his age, and most peculiarly fitted for the speciality of telegraphing, in which he had been engaged for some years prior to his death.

I cannot more truly present the character of Mr. Sadler than as recorded in the journal of proceedings of the telegraph company above mentioned, viz. :

At a meeting of the Board of Directors of the New-York and New-England Union Telegraph Company, holden at New-York city on the 17th of November, 1857, the following merited tribute to the memory of the late L. L. Sadler, an associate Director, and Treasurer and Secretary of the Company from its origin, was unanimously adopted :

*Whereas*, it hath pleased Almighty God to remove by death from our midst our associate Director, Treasurer and Secretary, the late L. L. Sadler, since the last monthly meeting of this Board; and it is befitting that at this first succeeding meeting we should express our sense of the exceedingly great loss which has befallen the interests and business of this Company, and ourselves, his associates in office, by this sudden dispensation, therefore,

*Resolved*, That to profound respect for his memory, we bear cheerful recollections of his uniform urbanity and exemplary worth, as a man, and of his scrupulous integrity, carefulness, and promptitude, as an officer; faithfully and perseveringly discharging all his varied duties with ability and fidelity, and maintaining a character for manly uprightiness in all his relations, and toward all men.

*Resolved*, That we sincerely lament his death, and mingle our sympathies with those of his bereaved widow and immediate relatives, in appreciation of their irreparable calamity in this event.

*Resolved*, That the Treasurer be, and is hereby directed, to continue the monthly salary to the widow of the deceased, which would have been payable to him, for the remainder of the official year for which he was elected Treasurer and Secretary, terminating on the thirtieth day of June next.

On motion of Mr. Lefferts—

*Resolved*, That as a further testimonial of the great regard we entertain for the memory of the worth and exemplary character of the deceased, the President and Mr. Smith be constituted a committee to prepare an appropriate memoir of his life, and that the same be extended upon the records of the Directors.

*Resolved*, That these resolutions be entered upon the records of the Directors, and that the President be requested to communicate a copy of the same to Mrs. L. L. Sadler, the widow of the deceased.

At a meeting of the Board of Directors, held in the city of New York, March 20th, 1858, the following proceedings transpired :

Pursuant to the vote of the Directors, November 17, 1857, the Committee report and place upon record, in behalf of the Company, the following brief memoir of the late L. L. SADLER :

The remains of REV. LEVI LINCOLN SADLER, who died somewhat suddenly (though for years an invalid), in Brooklyn, N. Y., at the residence

of his brother-in-law, Mr. Charles Munroe, on the 29th of October, 1857, were borne to the city of Portland, Maine, on the Monday following, and entombed, under the charge of two sorrowing brothers, and his brother-in-law (Hon. F. O. J. Smith), and Charles F. Wood, Esq., Superintendent of the "New-York and New-England Telegraph Company," of which Company the deceased was a Director, Secretary and Treasurer, from its origin. The funeral ceremonies were held in Brooklyn by the Rev. E. H. Chapin, of New-York city, and Rev. B. Peters, of Brooklyn, in a manner solemn, instructive, and every way consistent with the known convictions and quiet judgment of the lamented deceased.

Of the life, and performance of its duties throughout, of Mr. Sadler, others, to whose service in the ministry, as well as in secular affairs, he was devoted, will hereafter speak more becomingly than we can here; but a brief allusion to his characteristics is an appropriate tribute to his past relations to this company. He resided several years in the city of Portland, Maine, among numerous devoted friends. There he was also married in 1841, and there, also, he ably discharged the duties of pastor of the First Universalist Society, until broken health imperatively demanded that he should somewhat change his pursuits. None knew him but to respect him to the fullest extent of their knowledge of him, whether in secular, social, or temporal relations.

Previous, and down to the time of his call as pastor in Portland, Maine, he resided, and for some period of time he officiated as pastor of the Universalist Society, in New Bedford, Mass., where still survive many, very many, to whom his memory will be forever endeared by associations of profound mutual esteem and attachment.

From his early manhood he was deeply imbued with a mastering love and reverence for the teachings of the Gospel, and became a sincere convert to the doctrines and faith to which he clung throughout after life, and in which he felt ever prepared to encounter the demands of death.

Among his first labors, we believe, when scarcely having reached manhood, was a mission of his own conception, that occupied many months in execution, through western New-York and Ohio, in the formation of numerous local religious societies of the Universalist denomination, looking forward in them to what has since been, his judgment joyously realized in various localities, the growth of vigorous, and useful, and permanent associations of worshipping communities, where tall church-spires attest the footprints of this early pioneer of the doctrine of man's ultimate redemption from a condition of sinfulness and sin.

We allude to these sectarian labors of Mr. Sadler only in illustration of his life and character, and not as the sponsors of his religious views, nor to sit in judgment upon their merits or demerits as a creed. It is our high gratification to believe that in him, however, they never suffered detriment by affectation or abuse in any way. He was always tolerant, however decided for or against the views of others.

He was engaged for some time as pastor of the Universalist Society in Columbus, Ohio, which we believe was one he had organized; and at another period, before ministering as a permanent pastor in Portland, he was engaged in like duties in Bangor, Maine. But we leave to others, more conversant with his labors in the ministry, to particularize them. In the funeral service, Rev. Mr. Chapin alluded to them as within his own knowledge, in the most feeling and eloquent terms of eulogy and pleasurable remembrance. Suffice it to say, everywhere he resided he commanded the respect, and love, and confidence of his acquaintances in all his associations, both social and religious, for his ardent and sincere convictions, for his scrupulous advocacy of the right, under all circumstances, and in respect to every being and every creature, of every condition, under God's providence.

It was not choice, but seemingly necessity, imposed by the state of his health under an increasing bronchial affection, caused by his public speaking, and which laid the foundation of his final illness, that induced him to leave the cares and service of the ministry, for the most part, and engage in secular affairs. It was some eleven years since that he was thus circumstanced. Attracted by the beautiful mysteries of the Electric Telegraph, as a thing of curious art, as well as of unmeasured utility in the business world, he consented, upon the ardent solicitations of his brother-in-law, Mr. Smith, to become an extensive supervisor of its operations, in which he has ever since continued, winning alike the respect and confidence of the numerous business communities with whom he was brought into intercourse, and imparting a systematic responsibility and character to the operations of the lines which have been under his charge, unsurpassed, if equalled, by the services of any other individual engaged in the business.

Few men can ever know the embarrassments and perplexities which attended the inauguration and establishment of this new agency in the commercial and social world. It was like grasping and holding *the nerves* of a sensitive, jealous, untrained world of men, where the individual *most seen*, and not the yet untutored, inscrutable agency, and yet imperfectly adjusted physical means, would alone be recognized as the responsible author of every disappointment, as, perhaps, the contriver of every failure. The acting man it was, therefore, who became the focal point of every distrust—the accused exponent of every mystery connected with the great new agent. It is only those who have been, like Mr. Sadler, centrally circumstanced in the introduction and adaptation of this wonderful agent to the public comprehension and use, that can appreciate this fact in all its truthfulness and force. Nothing short of a well proved personal integrity, a calm endurance of angry suspicion without untimely resentment—a perseverance, with a will to repair whatever might have resulted from a mistake, accident, or ignorance, and a promptitude in reproof whatever might be of wrong in the operation of telegraphing in its earliest stages of use, coupled with clear knowledge of electric agencies and of mechanism, could succeed in winning to a telegraphic administration general confidence as a great business agent, and maintaining for it the good will of every class of the community. In all these needful capabilities Mr. Sadler proved himself a master, and a master so practically and so pre-eminently successful, that, at the close of his labors, to the widest extent of those interests that were intrusted to him, every associate of his, in whatever position, was ready to bear witness that no living man can make good to them his place and his usefulness. The records of his company, a company that now ranks among the fixed institutions of the country, bear an undying testimony to his fidelity, and industry, and grasp of practical superiority, that will not only forever speak to his honor, but remain an instructive example to others. His administration of the financial department of his company was exactly suited to the going down of every day's sun, and is a model record for others to imitate. But a few days only previous to his decease he attended the monthly meeting of his associate Directors in New-York, and enjoyed the high satisfaction, as the crowning performance of his official life's duties, of submitting to them the largest results of his financial administration that any month had wrought for his company, and although the settled gloom of pecuniary distress was still upon every other branch of industry, and upon almost every other industrial institution in the country; in view of this fact, coupled with his reports of other recent successful measures intrusted mainly to his official execution, gratefully did he remark to his friends just then, "I believe my star is at last in the ascendant for my friends."

Yet a better, a less troubled star of his glory, was then about to rise upon his vision, and bear him calmly, peacefully, resignedly, and confidently upward, even to the bosom of his everlasting God.

To his friends, and especially to those who knew him best, there is left this undying consolation, that never did man pass, in a useful sphere of activity, through the duties, obligations, and trials of life with more uniform composure and evenness of judgment and temper, with less of the taints of the pollutions of the world upon him, than did our departed and lamented friend. As a son, as a brother, as a husband especially, and as a friend of his kind everywhere and however circumstanced, his life was unexceptionable, and in every phase exemplary. His own home was the abode of his soul's pleasures and yearnings, and, without ostentation, it was the fullness of human happiness to every inmate. Although without children to weep his absence, the tears of a devoted wife, and the hallowed thoughts of endeared friends, will forever linger there, until the changes of earth and time shall order all hence and away.

Mr. Sadler was a native of Grafton, Mass., and was aged a few months more than fifty-one years. He has a brother, Judge E. B. Sadler, residing at Sandusky, Ohio; another, Mr. C. C. Sadler, a merchant in Philadelphia; another, Mr. Wm. W. Sadler, in New-Haven; another, Mr. Manlius Sadler, in Brookport, N. Y.; and one other, whose name we have not, residing in Buffalo, N. Y.—to each and all of whom the deceased was greatly endeared. Besides his labors to which we have alluded, he was, at times, a contributor to the editorial department of two or more religious periodicals, and published one or more treatises upon his religious doctrines. But in nothing of his productions is there any mark of acerbity or other feeling inconsistent with a well-disciplined benevolence and forbearance toward all men.

And it was the will of his Master in heaven, that was ever present to his mind as the ruling guide of all his actions. Well may the loss of such a man be deplored within and without the circle of his labors.

As a mark of regard for his memory, the officers of each of the six connecting railroads between New-York city, and the city of Portland accorded to his remains and their attendants the freedom of their roads on their sorrowful mission to and from his tomb.

## ANSON STAGER,

of Ohio.

THE subject of this memoir was born in Ontario county, State of New-York, April 20th, 1825, and for the first twenty years of his life he resided in the city of Rochester.

At an early age, and during the progress of his education, Mr. Stager entered the printing establishment of Mr. Henry O'Reilly, for the purpose of learning the "art preservative of all arts." His expertness soon became observable by his employers, and to him was intrusted service in the business, which, in most instances, required greater experience. His singular and perfect discriminating powers, gave him the advantage of readily determining matters, requiring the exercise of that peculiar talent necessary for success in the art of printing.

In 1846, Mr. Stager abandoned the vocation of printing, and adopted the telegraphic profession as an affair for life. He gave this new field of labor his whole mind, and he was not long in attaining an eminent position as a practical telegrapher, and to this day he holds the recognized honor of being the most expert manipulator in the service. He has been ambitious in the perfection of his profession, and his labors have been crowned with the most signal success. His career is worthy of imitation. He bid adieu to the art of printing, though with some reluctance, and followed in the service of his old employer, Mr. O'Reilly, in the then new and novel enterprise of telegraphing.

Mr. Stager entered into the new service with energy, and having become "quite an expert," as he was then called, he was placed on the first link of the O'Reilly lines, between Philadelphia and Harrisburg, in October, 1846. On the extension of the line west of the Alleghany mountains, he was transferred to the Pittsburg station. When the lines were extended west of Pittsburg, their manipulation at Pittsburg was placed under the care of Mr. Stager, and in their management he exhibited administrative abilities fully equal to the important and responsible position.

When the O'Reilly lines were extended to the Mississippi in the west, to the Lakes in the north, and to the Gulf of Mexico in the south, the Cincinnati station was the most commanding on those lines, requiring the first skill in manipulation and talent in administration. In the selection of the superior men for that station, Mr. Stager was among the first chosen, and at an early day thereafter he was made Chief Operator, having in charge the manipulating department of the respective lines centering in Cincinnati. No operator ever discharged the trust reposed in him more faithfully than did Mr. Stager, reflecting not only credit upon himself, but upon the enterprise.

Through the indefatigable energies and superior expertness of Mr. Stager, the modes of operating the apparatuses in the transmission and reception of despatches, both as to celerity and correctness, were perfected, so much so in reality that the Cincinnati station was then, and since, considered the model station on the American lines. He practically combined mechanical contrivances, coupling circuits together, so that the necessity of re-writing was dispensed with. This is not novel at the present moment, and its universality takes from the feat the greatness of the then recognized achievement. Those of us who commenced to toil



in this enterprise, at an early hour of the day, know well how to appreciate the consequence and merit of the success.

It was during his services in this station as chief operator, that he devised the plan of working any number of circuits, or lines, from the one voltaic organization. He was the first to accomplish the end by practical demonstration, notwithstanding others had theorized that it could be done. It was accomplished, however, by novel modes, original with Mr. Stager, essentially differing from the supposed theories advanced by others. He arranged the battery and the wires according to the laws of electrical phenomena, as manifested from time to time in the manipulation of the telegraph, observable to the operator. He connected the various lines centring at his station with the one battery, and successfully worked all of the different lines at the same time from the one battery. This was an achievement far ahead of any other progress of the age, and one entitling the inventor to more honor and reward than has fallen to his lot to realize.

During the years of 1848, '49, and '50, Mr. Stager was employed as an auxiliary in the Coast Survey Department of the United States Government. He was the telegrapher for the service, and was under the direction of the late Prof. Sears C. Walker, in "determining longitudes," "wave time of electric currents," and in testing the astronomical clocks of Profs. Mitchell and Locke. In this important service he won new laurels; and his ability was duly appreciated by the United States government.

In January, 1852, Mr. Stager was appointed superintendent of the new line of telegraph, constructed by the New York and Mississippi Valley Printing Telegraph Company. The line extended from Buffalo to Louisville, and operated the House Printing apparatus. During the same year his administration as superintendent was extended over the line from Buffalo to New-York City. These respective lines, and others east and west of Buffalo, were ultimately united, by lease, purchase, or otherwise, under the name of the Western Union Telegraph Company. This new organization has grown to be the largest and most extensive telegraph company in the world. Its lines extend over the northwestern states, and proximate fifteen thousand miles in length, and it is extending its lines with wonderful rapidity. This vast range of the telegraph has a centralized administration, under the direction of gentlemen of distinguished telegraphic ability. Each department is placed in charge of those competent for the discharge of the speciality; and in this manner it has gone on, like the rivulet that rises in the Rocky Mountains;—at its source very small, but ere it reaches the ocean it is gigantic in proportion and power, and is hailed as the "Father of waters."

The immense range of lines under the Western Union Company is supplied from one central station with all the various equipments, such as magnets, batteries, sounders, insulators, &c., &c. As general superintendent of these lines, Mr. Stager has done well for his company in the adoption of the "Supply Department," as great economy must result therefrom.

In connection with Mr. Wade, his sterling coadjutor, Mr. Stager completed a system of Railway Telegraphs which are now in successful operation throughout the northwest. He has had arranged all the necessary contrivances to effect the most good for that important public enterprise, having in view the welfare of the people and the interests of the respective companies. I have seen the various railway telegraph systems in Europe, the most prominent of which are the French, the Belgian, and the Prussian. But they are far behind the arrangements operated under the direction of Mr. Stager. No system of telegraph works with more perfection than that established on the American railways above

referred to. It is impossible to enter into an explanation of their utilitarian organization in this sketch, though nothing could give greater evidences of Mr. Stager's merits than its comprehension by the reader.

I have referred elsewhere in this work to the fact, that the operator on the American lines frequently cuts the wire on the route, and communicates with the distant station by manipulating the two ends of the wire together. This has been frequently done, but the most remarkable feats performed in the art of telegraphing have been by Mr. Stager, in the reception of messages by the motion of his tongue. One of these feats was, some years since, thus noticed by the press, viz.:

"An engine on the Pittsburg, Fort Wayne and Chicago Railroad broke down last week, at nine o'clock at night, nine miles distant from a station. The conductor went on foot through the snow to get another machine. A telegraph operator on one of the cars, named Stager, hearing the cause of the detention, got out and taking down the main wire from the pole alongside the track, cut it, 'dotted' the distress of his train to the Pittsburg and Brighton stations, and putting one of the brass points to his tongue, read the answer that an engine should be immediately sent, and then talked off this pleasant lightning to his anxious and impatient fellow-passengers."

It is difficult for one not acquainted with the art of telegraphing to appreciate this remarkable feat. In 1746, Muschenbroek received the first shock from the Leyden vial, of which he said, that "he felt himself struck in his arms, shoulders, and breast, so that he lost his breath, and it was two days before he recovered from the effects of the blow and the terror;" and that "he would not take a second shock for the kingdom of France." One century thereafter, the shock became intelligible, giving information from miles distant! The thought is too sublime!! Did I not know it to be true, both by observation and as a philosophical fact, I might question the truth of the record.

Mr. Stager projects his tongue so that he can see it, and then places one end of the wire above, and the other end below it. The operator three hundred miles distant, manipulates with the key of the apparatus, and the electric current when passing through the tongue from the end of one wire to that of the other, produces a convulsion which answers to the motion of the armature of the electro-magnet. These motions are intelligible to Mr. Stager, and in this manner he has received various messages at different times and under different circumstances.

Mr. Stager has never been an ambitious man for public notoriety. He has not sought office, but the office has sought him. In all his obligations with others he has performed his faith with the most complete satisfaction. He is young, and his future career cannot be else than one of usefulness and honor. At morn, noon, and eve, he can break bread with an estimable companion, and with those treasures given only by God to man. His home is decorated with ornaments purer and richer by far than the pearls gathered from the depths of the sea.

## TALIAFERRO P. SHAFFNER,

*of Kentucky.*

[In giving place here to the following brief biographical sketch of himself, the Editor deems it proper to say that he yields to the solicitations of friends, by one of whom it was written; he would also add that one prepared for and published some years since in *DR BOW'S REVIEW* and *HUNT'S MERCHANT'S MAGAZINE*, formed the basis of it, with such additions and emendations as seemed called for by the lapse of time since the publication referred to.]

MR. SHAFFNER was born in Smithfield, Jefferson county, Virginia, and the earlier part of his life was spent in that ancient commonwealth. At the age of thirteen he accompanied a relative to St. Charles county, Missouri, and participated in the establishment of the town of Flint-hill, in that county, and was actively engaged in all the varieties of western forest life. In the store, driving the team, at the plow, with the axe, he toiled faithfully—enduring with patient and becoming fortitude the privations and wearying cares and labors of the pioneers of the great West.

Having advanced sufficiently in his preparatory education, Mr. Shaffner, in 1840, commenced the study of the law, and in April, 1843, he was admitted to the Maryland bar. He returned to the West, and commenced the practice of law in Louisville, Kentucky, where he had previously resided some three years during his preliminary studies.

During the several years in which Mr. Shaffner was engaged in his studies, he did not devote himself exclusively to Blackstone, Coke, and Chitty. Under the especial instruction of the principal of the Alleghany Academy, he applied himself to the perfection of those attainments which he had commenced under his own guidance, and which were to invest him with those advantages which were most essential aids in the development of his energetic character.

By way of relieving the monotony of close and steadfast application, Mr. Shaffner, in time of vacation, undertook pedestrian tours to neighboring States, visiting all the institutions of learning and of interest in the States, north, south, and east. In these excursions he rendered himself familiar with the history and character, the statistics and people of every important town or city in the middle, eastern, and southern States. His topographical knowledge alone has to him been invaluable, and his impressions of the whole eastern and southern portion of this great republic are almost as thorough and perfect as if they were the result of laborious and scientific surveys. His motto seems to have been: "What is worth understanding at all, is worth understanding well;" and consequently he has not been content with less than a thorough knowledge of all he has investigated.

Early in his career as a practitioner at the bar, Mr. Shaffner employed his spare hours in writing for various magazines, annuals, &c. In 1844, he was selected to act as an editor of the leading publication of the Order of Odd-Fellows.

In 1845, he was selected to edit the official organ of the Grand Lodge of Masons in Kentucky.

In 1847, Mr. Shaffner prepared a small volume, known as the "Kentucky Register," containing statistics and much useful information for the officials of the government and others.

In 1844, Mr. Shaffner was elected Secretary of the Kentucky Historical Society, and for several years he continued to perform the duties of that important position with much credit. In the same year he was selected as Recording Secretary of the Home and Foreign Missionary Society of the Methodist Church, South.

The various labors, above recited, were enterprises in which Mr. Shaffner engaged his spare hours, having in view the perfection of his education in general.

In 1844, he was in Baltimore, and witnessed the operation of the telegraph, then under the direction of Prof. Morse. From the moment of first seeing the apparatus, he commenced the study of its operation. On his return to Kentucky, he commenced his efforts for the extension of the telegraph to the West. The enterprise was new, and Mr. Shaffner's labors did not receive the appreciation they merited. So little confidence was placed in the telegraph, that when, about 1846, he sought for the passage of a bill by the Legislature of Kentucky, for the protection of the telegraph, it only passed by one vote in the affirmative, and none in the negative, in the Senate, all the other senators preferring not to vote, than to oppose the measure, so energetically pressed by Mr. Shaffner.

In the year 1846, Mr. Shaffner commenced active efforts for the extension of the telegraph to Louisville, and places south. In 1847, in association with Col. William Tanner, he commenced the construction of the first line south of the Ohio river, the first section being from Louisville to Lexington, Kentucky, and the second to Nashville, Tennessee, both of which were completed early in 1848.

In the fall of 1848, Mr. Shaffner, in association with Messrs. Thomas C. and William L. McAfee, commenced the construction of the St. Louis and New-Orleans telegraph, which was completed in 1850.

In the spring of 1850, he associated with him Mr. Isaac M. Veitch, and commenced the construction of the telegraph from St. Louis to St. Joseph, Missouri, connecting the principal river towns.

On the organization of the St. Louis and New-Orleans Company, Mr. Shaffner was elected President of the Company, and was successively re-elected until he resigned the position, a few weeks after the annual meeting in 1853.

During the same years he was an active assistant to Mr. Veitch in the administration of the St. Louis and Missouri River Company.

In the spring of 1852, he was unanimously elected Secretary of the New-Orleans and Ohio Telegraph Company, extending from Pittsburg, Pennsylvania, through Louisville to New-Orleans.

Although Mr. Shaffner was thus at the same time singularly connected with three companies, extending over several thousands of miles, yet his duties to each were fully discharged to the satisfaction of the respective companies.

In the spring of 1853, he was elected Secretary of the American Telegraphic Confederation, an association formed at Washington by representation from the different companies in America. Having accepted the above position, he returned to the West, resigned the various offices he held there, and arranged his affairs for taking up his residence in the East; previous to doing which, however, and during the summer months, he submerged cables across the Mississippi, Ohio, and Tennessee rivers. In the fall he entered upon the duties of his new position at Washington.

In regard to his labors in the West, a publication thus spoke of them in 1853 :

"From having been one of the most prudent and energetic men of the age, Mr. Shaffner has not toiled in vain. In addition to the accumulation of other interests, he has become proprietor of the largest amount of telegraph capital in the Western and Southern country, and, except the patentees, doubtless the largest in the United States. This immense interest demands and receives his constant attention; and his whole time and undivided labors are devoted to the exclusive duties he owes as sole conductor of the management of the one line, and the co-operative services he most assiduously renders as secretary of the united lines. In both stations he employs that prudent economy and untiring energy which have distinguished him in every station he has occupied; and the beneficial results arising therefrom are visible in the improved condition of the resources and revenues of the lines, as far as he controls.

"It was remarked that Mr. Shaffner devoted his whole time to the fulfilment of his official undertakings. Perhaps such another instance of complete absorption in the performance of what he considers his duties, is not to be found. Without hesitation, he enters upon and prosecutes the most arduous and difficult, not to say hazardous, tasks that could be imposed. In the office, he is unremitting, and consequently performs an enormous amount of labor. But, when he deems it expedient, he is out upon the line, partaking of the toil and exposure, and braving the severest weather and the most perilous situations. His efforts to keep up the telegraphic connections between New-Orleans and St. Louis, with uninterrupted regularity, while the Ohio river was filled with floating ice, crashing and grating against the shores—constantly crossing, while steam navigation was entirely suspended—when the common ferries plied no more, and laborers and men, used to exposure, refused to encounter the hazardous enterprise, even for the certainty of rich reward—commanded the admiration of every beholder. He was not to be deterred by danger or severity of weather. Succeeding in securing the services of two of his men, he daily crossed the Ohio, battling with the floating ice, that momentarily threatened to crush his frail bark, and consign him and his companions to a watery grave. But Providence smiled upon these unparalleled efforts to preserve a telegraphic connection; and he had the satisfaction of knowing, while his general health was unimpaired, that he had performed a great service, from which one of feeble temperament and less determination would have shrunk as a thing impracticable.

"The acquaintance and connection of Mr. Shaffner with the Hon. Amos Kendall and Professor Morse, have been intimate and most agreeable to all parties. He has on all occasions, and with the earnest eloquence which distinguishes his conversations or public addresses, defended the rights of the latter to the profitable results of his great invention; and to his ability and persevering energy, much of the favorable feeling which exists throughout the community toward that desideratum is decidedly due.

"As a financier, Mr. Shaffner has exhibited a prudence and foresight which have commanded the confidence of the many large banks and banking houses with which he has had business transactions. The revenues of the lines with which he is connected as president or secretary, amount to about three hundred thousand dollars per annum, and this large sum comes under his special supervision in its disbursement. That it has been scanned with unwavering fidelity and consummate ability none can for a moment doubt, who witness the unflinching and active zeal with which he pursues the difficult and intricate labors by which he is surrounded, and which would puzzle and confuse, if not overwhelm

any one less methodical and less indefatigable. The system is to him a science, and he comprehends it in general and particular. There is nothing beyond the grasp of his quick perception, and no *minutiae* so small to escape his penetration.

"Mr. Shaffner is a young man, notwithstanding his active life has devolved the performance of more labors upon him, and caused him to encounter more vicissitudes, than ordinarily fall to the lot of twice his number of years. Strictly temperate in his habits, undeviating in the performance of the duties which the laws of God and man inculcate, blest with all that can make home happy, he can be pointed to as an example worthy of all imitation."

Early in 1854, Mr. Shaffner visited New-York city, to aid in the re-organization of the Newfoundland Telegraph Company, the secretaryship of which had been offered to him with a salary of twelve thousand dollars per annum. The new company was organized, having as proprietors some ten members, of whom Mr. Shaffner was one. Not satisfied with the administration of the company's affairs, he withdrew from the company forever.

Mr. Shaffner had entered into the Newfoundland enterprise with a view of carrying out his ocean telegraph, which he had commenced the year before. About the same time the phenomenon of the retardation of the electric force, transmitted through sub-aqueous conductors, was announced by Prof. Faraday. This new development in philosophy caused Mr. Shaffner to abandon his idea of a telegraph from Newfoundland to Ireland, and he commenced his labors for a telegraph to run from Labrador to Greenland, to Iceland, to the Faroe Isles, and, with branches, to Norway and Scotland. To this end he visited Europe in 1854, and obtained a Royal Concession from His Majesty the King of Denmark for the exclusive right to run the telegraph over the route above mentioned for the term of one hundred years. He also obtained concessions from Norway and Sweden for the same purposes.

While Mr. Shaffner was at Copenhagen, His Excellency Baron Stenberg, Envoy Extraordinary and Minister Plenipotentiary for the government of Russia, notified him that His Majesty, the Emperor Nicholas, desired him to visit St. Petersburg, and that all the necessary facilities had been commanded. In accordance with the august behest, Mr. Shaffner visited St. Petersburg, and was received by the imperial government with distinguished honor, and after the fulfilment of his mission to Russia, he received from the Emperor evidences of appreciation for the services he had rendered.

Mr. Shaffner returned to America in the latter part of 1854, and continued his efforts for the perfection of his Atlantic Ocean Telegraph. In the spring of 1855, he was again requested to visit St. Petersburg, by order of His Majesty the Emperor Nicholas, for the purpose of aiding the imperial government to construct a railway to the Crimea. His visit to St. Petersburg in 1855 was crowned with success in some important negotiations, though the termination of the war, soon thereafter, interfered with the consummation of the railway and telegraphic enterprises in which Mr. Shaffner was engaged for the benefit of the imperial government.

During Mr. Shaffner's visits to Europe, in 1854-57, he was honored with the attention of the distinguished telegraphers of that continent. His Majesty, Louis Napoleon, Emperor of the French, accorded to him full honor, and directed the various officials to expose to Mr. Shaffner's inspection and information whatever he desired in the telegraphic service.

The officials in Belgium, Holland, Hanover, Prussia, Denmark, Sweden,

Russia, Austria, and the German States generally, and other parts of the continent, accorded to him due honor as one of the most expert telegraphers of the age.

Mr. Shaffner published his *Telegraph Tariff Scale* in 1853, and in 1854-'55 his *Telegraph Companion*, 2 vols. octavo. These works were the most extensive ever published concerning the telegraph in America.

When Mr. Shaffner entered the telegraphic service as a profession, in 1847, he abandoned the general practice of law, and his labors in that science, since then, have been confined to such cases as naturally spring from the new engagement. Having been admitted to the bars of the inferior and superior courts of the several States, Mr. Shaffner was duly admitted and qualified as a member of the bar of the Supreme Court of the United States, in 1854, on motion of Mr. Crittenden, the honorable Senator from Kentucky. His knowledge of legal jurisprudence and its history, gave him great advantage in his negotiations at the different courts of Europe.

# INDEX.

(FOR TABLE OF CONTENTS, SEE PAGE 7.)

|                                             | PAGE.    |                                                  | PAGE.    |
|---------------------------------------------|----------|--------------------------------------------------|----------|
| Administration of American Telegraphs       | 745      | Batchelder's Insulator                           | 545      |
| "    French                                 | 768      | Battery, Voltaic Pile                            | 81       |
| "    Russian                                | 779      | "    "    Chemical and Electrical action of      | 86       |
| "    Asiatic                                | 799      | "    "    Cruikshank's                           | 88       |
| Agamemnon's Telegraph                       | 21       | "    "    Wollaston's Improvement in             | 90       |
| Alarm Telegraph, Cooke's                    | 185      | "    "    Daniell's                              | 90       |
| Alexander's Electric Telegraph              | 139      | "    "    Smee's                                 | 93       |
| Alphabet of Steinheil's Telegraph           | 177      | "    "    Bunsen's                               | 95       |
| "    Chappé                                 | 34       | "    "    Grove's                                | 96       |
| "    Bain's                                 | 361      | "    "    Chester's Improvement in               | 102      |
| "    the English                            | 221      | "    "    of the Main Line                       | 487      |
| "    Morse Telegraph, American              | 469      | "    "    Stager's Arrangement of                | 492      |
| "    Morse Telegraph, Austro-Germanic       | 472      | Baker's, Henry N., Telegraph Improvement         | 728      |
| "    Morse Telegraph, European              | 474      | Bavarian Insulator                               | 552      |
| "    Morse Telegraph, Russian               | 476      | Binding Screws                                   | 442      |
| Ampère's Discoveries                        | 115      | Biographical Sketch of S. F. B. Morse            | 803      |
| American Wire, Strength of                  | 521      | "    "    Amos Kendall                           | 808      |
| "    Telegraph Insulation                   | 536      | "    "    J. H. Wate                             | 831      |
| "    Subterranean Telegraphs                | 587      | "    "    F. O. J. Smith                         | 811      |
| Apparatus of Chappé Semaphore Telegraph     | 32       | "    "    Wm. M. Swain                           | 822      |
| Apparatus of Electrical Telegraph           | 62       | "    "    John J. Speed                          | 829      |
| Apparatus of Steinheil's Electric Telegraph | 159      | "    "    Anon Stager                            | 837      |
| Apparatus of Cooke's Electric Telegraph     | 199, 216 | "    "    Levi L. Sadler                         | 833      |
| Apparatus of Davy's Electric Telegraph      | 255      | "    "    W. Tanner                              | 825      |
| "    Brett's Printing                       | 273      | "    "    Tal. P. Shaffner                       | 840      |
| "    Magnetic                               | 286      | Bishop's Submarine Cables                        | 603      |
| "    Highton's Needle                       | 295      | Black Sea                                        | 618      |
| "    Bakewell's Copying                     | 304      | Blank Forms of the English Telegraphs            | 246      |
| "    Nott's Electric                        | 310      | "    "    American                               | 467      |
| "    Siemens & Halskic's                    | 313      | Boston Fire Alarm Telegraph Insulator            | 545      |
| "    French State Electric                  | 325      | Bonnelli's Report on Submarine Electric Currents | 508      |
| "    "    Railway                           | 334      | Brett's Printing Telegraph                       | 278      |
| "    "    Bull                              | 346      | Breguet's Telegraph Improvement                  | 344      |
| "    "    Bain's Chemical                   | 354      | "    "    Paratonnerre                           | 578      |
| "    "    Froment's Dial                    | 373      | Bright's Telegraph Apparatus                     | 292      |
| "    "    House's Printing                  | 391      | "    "    on Return Currents                     | 503      |
| "    "    Morse's Original                  | 404      | "    "    Insulator                              | 535      |
| "    "    "    Modern                       | 422      | British Subterranean Telegraphs                  | 589      |
| "    "    "    for Repeating                | 494      | "    "    American                               | 756      |
| "    "    "    Sounding the Ocean           | 652      | Brackets for Insulators                          | 542      |
| Arago's Discoveries                         | 115      | Brimstone Insulator                              | 539      |
| Arbitrary Signals of Morse's Telegraph      | 477      | Bunsen's Voltaic Battery                         | 95       |
| Arrangement of English Telegraph Wires      | 234      | By-Laws of American Telegraphs                   | 750      |
| Asiatic Telegraphs, History of              | 799      | Cables, American Submarine                       | 599      |
| Attraction and Repulsion                    | 67       | "    European                                    | 607      |
| Atlantic Telegraph Company                  | 622      | Cagliari Telegraph Station                       | 620      |
| "    Telegraphs Projected                   | 655      | Celerity of English Telegraph Signaling          | 240      |
| Austrian Insulator                          | 553      | "    "    Chappé Semaphore                       | 42       |
| Axial Magnetism                             | 130      | Channing & Farmer's Telegraph Improvement        | 730      |
| Bain's Printing Telegraph                   | 269      | Charter form of American Telegraphs              | 749      |
| "    Chemical                               | 354      | Charing Cross Telegraph Station                  | 233, 242 |
| Baltic Sea Telegraph Cable                  | 616      |                                                  |          |
| Balize                                      | 617      |                                                  |          |
| Bakewell's Copying Telegraph                | 304      |                                                  |          |





| PAGE.                                                     | PAGE.         |                                                           |          |
|-----------------------------------------------------------|---------------|-----------------------------------------------------------|----------|
| Electric Telegraph, Soemmering's . . . . .                | 142           | History of the English Telegraph . . . . .                | 179      |
| "    Steinheil's . . . . .                                | 157           | "    Morse . . . . .                                      | 402      |
| "    Westbrook & Rogers' . . . . .                        | 370           | Hindustan Subterranean Telegraphs . . . . .               | 595      |
| "    Vail's Printing . . . . .                            | 382           | "    Telegraph Poles . . . . .                            | 698      |
| "    Conductors . . . . .                                 | 513           | House's Printing Telegraph . . . . .                      | 391      |
| Electro-Magnet of Morse Telegraph, 1844 . . . . .         | 444           | "    Insulator . . . . .                                  | 545      |
| "    "    Modern . . . . .                                | 446           | Holland Submarine Cable . . . . .                         | 614      |
| "    "    Pocket . . . . .                                | 450           | "    Insulator . . . . .                                  | 552      |
| "    "    Sonder 451, 450 . . . . .                       | 450           | Holyhead Submarine Cable . . . . .                        | 609      |
| English Telegraph Insulation . . . . .                    | 529           | Hughes', David E., Telegraph Improve-<br>ment . . . . .   | 721      |
| "    and Holland Cable . . . . .                          | 614           | Humaston, John P. . . . .                                 | 737      |
| "    Telegraph Wire, Strength of . . . . .                | 521           | Ice on Telegraph Wire . . . . .                           | 712      |
| "    Semaphore Telegraph . . . . .                        | 47            | Igniting Gas with the Finger . . . . .                    | 69       |
| "    Telegraph Poles . . . . .                            | 606           | Induction, Resistance to . . . . .                        | 24       |
| "    Subterranean Telegraphs . . . . .                    | 589           | Induced Magnetism . . . . .                               | 108      |
| "    Submarine . . . . .                                  | 607           | Incidents of American Telegraph Station . . . . .         | 462      |
| Elevating Wire over River Crossings . . . . .             | 660, 365      | Injection of Telegraph Poles . . . . .                    | 688      |
| Elliott's Flint Insulator . . . . .                       | 549           | Indians, Telegraph of . . . . .                           | 24       |
| Employés, Qualification of, American . . . . .            | 761           | Indian, Execution of Rescaped by Tele-<br>graph . . . . . | 464      |
| "    "    French . . . . .                                | 773           | Iron Insulator, American . . . . .                        | 543      |
| "    "    Hindustan . . . . .                             | 801           | Intensity of the Electric Current . . . . .               | 498      |
| Erection of Telegraph Poles . . . . .                     | 672           | Interior of English Telegraph Station . . . . .           | 233      |
| Expeditions, Atlantic Telegraph . . . . .                 | 622           | "    Charing Cross . . . . .                              | 233      |
| European Submarine Telegraphs . . . . .                   | 607           | "    Tunbridge . . . . .                                  | 235      |
| "    Morse's Alphabet . . . . .                           | 474           | "    Lothbury . . . . .                                   | 243      |
| Escape of Electric Currents . . . . .                     | 497           | "    American . . . . .                                   | 458      |
| Example of Manipulation of Morse Tele-<br>graph . . . . . | 478           | "    Cincinnati . . . . .                                 | 458      |
| Experimental Line, America, constructed . . . . .         | 417           | "    Receiving Department . . . . .                       | 459      |
| Escapement Apparatus of Cooke's Tele-<br>graph . . . . .  | 188           | "    Operating . . . . .                                  | 461      |
| Faraday on Return Currents . . . . .                      | 501           | Insulation, Gutta-Percha . . . . .                        | 524      |
| Farley's Paratonnerre . . . . .                           | 574           | "    English Telegraph . . . . .                          | 529      |
| Farmer's, Moses G., Telegraph Improve-<br>ment . . . . .  | 721, 724, 730 | "    American . . . . .                                   | 636, 679 |
| Failure of the Atlantic Telegraph . . . . .               | 637           | "    French . . . . .                                     | 549      |
| Faber, M., of Danish Telegraphs . . . . .                 | 114           | "    Sardinian . . . . .                                  | 551      |
| First Dispatch over Morse's Telegraph . . . . .           | 421           | "    Bavarian . . . . .                                   | 552      |
| Fog conducting the Current . . . . .                      | 497           | "    Holland . . . . .                                    | 552      |
| Forms of English Telegraph Station . . . . .              | 246           | "    Austrian . . . . .                                   | 553      |
| "    American . . . . .                                   | 467           | "    Prussian . . . . .                                   | 558      |
| Franklin's Electrical Theories . . . . .                  | 54            | "    Russian . . . . .                                    | 554      |
| "    Kite Experiments . . . . .                           | 60            | "    Hindustan . . . . .                                  | 556      |
| French Electric Telegraph . . . . .                       | 325           | "    Subterranean . . . . .                               | 587      |
| "    Railway . . . . .                                    | 334           | Invention of Cooke's Telegraph . . . . .                  | 178      |
| "    Electric Telegraph Bell . . . . .                    | 346           | "    Morse's . . . . .                                    | 402      |
| "    Telegraph Insulator . . . . .                        | 549           | "    Steinheil's . . . . .                                | 178      |
| "    Railway Paratonnerre . . . . .                       | 579           | "    Combined Circuits by Morse . . . . .                 | 411      |
| "    State Telegraph . . . . .                            | 580           | Intensity Force of Batteries . . . . .                    | 104      |
| "    Subterranean Telegraphs . . . . .                    | 587           | International Tariff, European . . . . .                  | 784      |
| Froment's Telegraphs . . . . .                            | 373           | Implements for building Telegraph Lines . . . . .         | 669      |
| Flint Glass Insulator . . . . .                           | 547           | Improvements in Telegraph Apparatuses . . . . .           | 718      |
| Galvani's Discovery . . . . .                             | 77            | "    Coleman's, Andrew . . . . .                          | 729      |
| Galvanized Wire (see zinc-coated) . . . . .               | 516           | "    Channing and Farmer's . . . . .                      | 730      |
| Gauss and Weber's Electric Telegraph . . . . .            | 137           | "    Clay's, Edward C. . . . .                            | 733      |
| Gas, Igniting of, with the Finger . . . . .               | 69            | "    Baker's, Henry N. . . . .                            | 723      |
| Germanic Telegraph . . . . .                              | 313           | "    Farmer's, Moses G., 721, 724, 730, 736 . . . . .     | 736      |
| Gisborne's Insulator . . . . .                            | 540           | "    Hughes, David E. . . . .                             | 721      |
| Glass Insulator . . . . .                                 | 529           | "    Humaston's, John P. . . . .                          | 737      |
| Gonon's Semaphore Telegraph . . . . .                     | 48            | "    Kirchhoff's, Charles . . . . .                       | 718      |
| Gold Leaf Electrometer Telegraph . . . . .                | 295           | "    Partridge's, Albert J. . . . .                       | 726      |
| Grove's Voltaic Battery . . . . .                         | 96            | "    Smith's, John E. . . . .                             | 732      |
| Gauge of Telegraph Wire . . . . .                         | 522           | "    Wesson's, W. D. . . . .                              | 738      |
| Gutta-Percha Insulation . . . . .                         | 524           | "    Woodman and Farmer's . . . . .                       | 736      |
| Guyot's Semaphore Telegraph . . . . .                     | 49            | Irish Channel Telegraph . . . . .                         | 612, 614 |
| Hard Rubber Insulator . . . . .                           | 546           | Jar, Leyden, Discovery of . . . . .                       | 53       |
| Hague Submarine Cable . . . . .                           | 615           | Joints of Telegraph Wire . . . . .                        | 704      |
| Henry's Electro-Magnet . . . . .                          | 117           | Kendall, Amos, Agent for Morse . . . . .                  | 420      |
| Henry's Magnetic Telegraph . . . . .                      | 289           | "    Biographical Sketch of . . . . .                     | 808      |
| "    Experiments on Atlantic Tele-<br>graph . . . . .     | 641           | Kirchhoff, Charles, Telegraph Improve-<br>ment . . . . .  | 718      |
| Highton's Electric Telegraph . . . . .                    | 295           | Laying the Atlantic Cable . . . . .                       | 625, 634 |
| "    Insulator . . . . .                                  | 583           | "    Submarine Cables, American . . . . .                 | 602      |
| "    Paratonnerre . . . . .                               | 566           | "    "    European . . . . .                              | 610      |

|                                             | PAGE.         |                                          | PAGE.    |
|---------------------------------------------|---------------|------------------------------------------|----------|
| Lead-covered Wire.....                      | 587, 606      | Office Regulations, American.....        | 752      |
| Leyden Jar, Discovery of.....               | 53            | Ohm's Mathematical Formulas.....         | 86       |
| "    Experiments.....                       | 70            | Operating Department, English Tele-      | 233, 235 |
| Lever Key of Morse Telegraph.....           | 425, 432, 434 | graph.....                               |          |
| Lightning and Electricity identical.....    | 56            | Operating Department, Morse's.....       | 458      |
| Lighting Gas with the Finger.....           | 69            | O'Reilly's Line, Insulators.....         | 541, 678 |
| Lightning striking the Telegraph.....       | 572           | "    Contract with Morse.....            | 745      |
| "    Arresters.....                         | 564           | Origination of Telegraph Lines, America  | 745      |
| Load-Stone.....                             | 105           | Organization.....                        | 748      |
| Lomond's Telegraph.....                     | 132           | Orfordness Cable.....                    | 614      |
| Local Circuit invented by Morse.....        | 418           | Ostend and Dover Cable.....              | 613      |
| Lothbury Telegraph Station.....             | 243           | O'Shaughnessy's Insulator.....           | 556      |
| Magnetism.....                              | 105           | Paratonnerres, Telegraphic.....          | 564      |
| Magnets, Permanent.....                     | 105           | "    "    Breguet's.....                 | 578      |
| "    Electro.....                           | 120           | "    "    French State.....              | 580      |
| "    First Electro.....                     | 417           | "    "    "    Railway.....              | 579      |
| "    Construction of, by Morse, 1844.....   | 444           | "    "    "    Fardley's.....            | 574      |
| "    Modern Electro.....                    | 446           | "    "    "    Highton's.....            | 564      |
| Magnetic and Voltaic Electricity.....       | 288           | "    "    "    Meisner's.....            | 575      |
| Magneto-Electric Telegraph.....             | 163, 286      | "    "    "    Nottebohn's.....          | 577      |
| Magnetism, Generation of.....               | 130           | "    "    "    Reid's.....               | 567      |
| "    Axial.....                             | 130           | "    "    "    Smith's, C. T.....        | 570      |
| "    Induced.....                           | 108           | "    "    "    Steinheil's.....          | 573      |
| "    Electro.....                           | 114           | "    "    "    for River Crossings.....  | 571      |
| "    and Electro-Magnetism.....             | 129           | Patent Franchises, America.....          | 765      |
| "    Magnetic Needle.....                   | 106           | "    Morse's Administration of.....      | 420      |
| "    Magnetometers.....                     | 125           | Paying out Submarine Cable.....          | 610      |
| Main Line Circuits Described.....           | 483           | Partridge's, A. J., Telegraphic Improve- | 726      |
| Main Line Batteries, Adjustment of.....     | 487           | ment.....                                |          |
| Machine, Electrical.....                    | 62            | Penalty for refusing Dispatches, America | 764      |
| Manipulation of the Chappé Telegraph.....   | 38            | Permanent Magnets.....                   | 106      |
| "    Cooke.....                             | 199           | Pile, Voltaic.....                       | 79       |
| "    English.....                           | 216, 233      | Positive Electricity.....                | 55       |
| "    Morse.....                             | 402, 478      | Pole Changer.....                        | 436      |
| "    Bain.....                              | 354           | Port Rule of Morse's Telegraph.....      | 407      |
| "    French State.....                      | 325           | Polybius' Telegraph.....                 | 20       |
| "    "    Railway.....                      | 334           | Port Patrick Cable.....                  | 614      |
| "    Froment's.....                         | 373           | Poles, Telegraph, Erection of.....       | 672      |
| "    House.....                             | 398           | "    "    Timber for.....                | 681      |
| Making Submarine Cables, American.....      | 602           | "    "    on American Lines.....         | 681      |
| Malta Telegraph.....                        | 620           | "    "    French.....                    | 688      |
| Masts for Telegraph Crossings.....          | 657           | "    "    Injection of.....              | 688      |
| Maury on Ocean Telegraphs.....              | 655           | "    "    English.....                   | 696      |
| Mechanical Telegraphs, Cooke's. 185, 190,   | 213           | "    "    Hindustan.....                 | 698      |
| "    Wheatstone's.....                      | 209           | Printing Telegraph, Bain's.....          | 299      |
| Mediterranean Telegraph, Working of.....    | 508           | "    "    Brett's.....                   | 273      |
| "    Cable.....                             | 618           | "    "    Froment's.....                 | 373      |
| Metals, conductivity of.....                | 513           | "    "    House's.....                   | 391      |
| Message Forms of English Telegraph.....     | 246           | "    "    Vail's.....                    | 382      |
| "    American.....                          | 467           | Prussian Semaphore Telegraph.....        | 46       |
| Meisner's Paratonnerre.....                 | 575           | "    Subterranean.....                   | 687      |
| Mending Subterranean Telegraphs.....        | 597           | "    Insulator.....                      | 553      |
| Morse, Samuel F. B., Biographical Sketch    | 803           | Protection to Telegraphs.....            | 763      |
| of.....                                     |               | Prince Edward's Island Cable.....        | 616      |
| Morse Telegraph Alphabet, American.....     | 469           | Quantity Current of Electricity.....     | 497      |
| "    "    Austro-Germanic.....              | 472           | Qualification of Telegraph Employés,     | 781      |
| "    "    European.....                     | 474           | "    American.....                       |          |
| "    "    Russian.....                      | 476           | Qualification of Telegraph Employés,     | 778      |
| "    "    Circuits.....                     | 480           | "    French.....                         |          |
| "    "    Electro-Magnetic.....             | 402           | Qualification of Telegraph Employés,     | 801      |
| "    "    Original Model of.....            | 404           | "    Hindustan.....                      |          |
| "    "    Chemical.....                     | 386           | Railway Telegraph, French.....           | 334      |
| Native Magnetism.....                       | 105           | Resinous Electricity.....                | 53       |
| Needle, Magnetic.....                       | 106           | Resistance to Induction.....             | 67       |
| "    Telegraph, described.....              | 216           | Repulsion and Attraction.....            | 67       |
| Negative Electricity.....                   | 55            | Reizen's Electric Telegraph.....         | 133      |
| Nelson's Monument—Electric TimeBall.....    | 741           | Receiving Telegraph.....                 | 170, 402 |
| Newall and Co.'s Submarine Cables.....      | 608           | Receiving Department, Lothbury Sta-      | 243      |
| Non-conductors of Electricity.....          | 52            | tion.....                                |          |
| Notti's Electric Telegraph.....             | 310           | Receiving Department, Cincinnati.....    | 458      |
| Nottebohn's Circuit Changer.....            | 441           | "    by Sound.....                       | 462      |
| "    Paratonnerre.....                      | 577           | Regulations on French Telegraphs.....    | 768      |
| Ocean Telegraphy.....                       | 649           | "    "    American.....                  | 745      |
| Orsted, Discovery of Electro-Magnetism..... | 114           | "    "    Russian.....                   | 777      |

|                                           | PAGE.    |
|-------------------------------------------|----------|
| Regulations on Hindostan Telegraph...     | 799      |
| Repairing of Telegraph Lines .....        | 701      |
| Register, Morse's Telegraph, 1844.....    | 423      |
| "    "    Modern. 452-54 .....            | 452-54   |
| Repeating Arrangement.....                | 494      |
| "    of Circuits.....                     | 486      |
| Retardation of Electric Currents, Sub-    |          |
| marine .....                              | 506      |
| Return Currents, Submarine.....           | 501      |
| Reld's Paratonnerre.....                  | 567      |
| Right of Way for the Telegraph, America   | 766      |
| River Crossings, America.....             | 599      |
| Ronald's Electric Telegraph.....          | 147      |
| "    Electrograph .....                   | 153      |
| Rogers and Westbrook's Chemical Tele-     |          |
| graph .....                               | 370      |
| Rubber, Insulator.....                    | 545      |
| Russian .....                             | 554      |
| "    Subterranean Telegraphs.....         | 587      |
| "    Government .....                     | 577      |
| Sadler, Levi L., Biographical Sketch of.. | 833      |
| Salva's Electric Telegraph.....           | 135      |
| Sardinian Insulator.....                  | 551      |
| Schelling's Electric Telegraph.....       | 136      |
| Screws for uniting Wires.....             | 442      |
| Semaphore Telegraph, History of.....      | 27       |
| "    Adoption of, in France .....         | 78       |
| "    Extension over Europe .....          | 28       |
| "    German Station, 1798.....            | 29       |
| "    in Russia.....                       | 30       |
| "    Russian Station.....                 | 31       |
| "    Chappé's System.....                 | 32       |
| "    Alphabet.....                        | 34       |
| "    Celerity of.....                     | 42       |
| "    English System.....                  | 47       |
| "    Gonon's System.....                  | 48       |
| "    Guyot's .....                        | 49       |
| Second Circuit, English.....              | 194      |
| "    American .....                       | 411      |
| Seimens and Halskie's Telegraph.....      | 313      |
| "    Insulator.....                       | 554      |
| See-see-sah-ma, Execution of, respited... | 464      |
| Signal, Arbitrary, Morse Telegraph.....   | 477      |
| Signalling by English Telegraph.....      | 240      |
| Single Needle Telegraph.....              | 216      |
| Shaffner's Submarine Cable.....           | 600      |
| "    Biographical Sketch of.....          | 840      |
| Shooter's Hill Experiment.....            | 488      |
| Sleet on Telegraph Wires.....             | 712      |
| Smith, F. O. J., engages in Morse's Tele- |          |
| graph .....                               | 811      |
| Smith, F. O. J., Biographical Sketch of.. | 413      |
| "    Report in Congress.....              | 570      |
| Smith's, C. T., Paratonnerre.....         | 354      |
| Smith and Bain's Telegraph.....           | 782      |
| Smith's, John E., Telegraph Improve-      |          |
| ment.....                                 | 93       |
| Smee's Voltaic Battery.....               | 142      |
| Soemmering's Telegraph.....               | 143      |
| "    Apparatus and Manipula-              |          |
| "    tion.....                            | 456-6    |
| Sounders for Morse's Telegraph.....       | 462      |
| Sound, Receiving by.....                  | 649      |
| Sounding the Ocean.....                   | 409      |
| Specimen of Writing by Telegraph.....     | 829      |
| Speed, jun., John J., Biographical Sketch |          |
| of.....                                   | 490      |
| Speed, jun., John J., combined Circuits.  | 541      |
| "    Insulator .....                      | 709      |
| Spurs, Telegraph Repairing.....           | 704, 709 |
| Splicing Telegraph Wire.....              | 597      |
| "    Subterranean Wires.....              | 51       |
| Static Electricity.....                   | 837      |
| Stager, Anson, Biographical Sketch of..   | 492      |
| "    Circuit Arrangement.....             | 492      |
| "    Application of Battery.....          | 492      |

|                                         | PAGE.           |
|-----------------------------------------|-----------------|
| Stations, Interior of.....              | 233-5, 243, 458 |
| Steinheil's Telegraph Described.....    | 147             |
| "    Conductors of.....                 | 159             |
| "    Discoveries and Inventions.....    | 178             |
| "    Paratonnerre.....                  | 573             |
| Strength of Telegraph Wire.....         | 619             |
| Sturgeon's Electro-magnet.....          | 117             |
| Submarine Telegraphs, American.....     | 600             |
| "    "    European.....                 | 607             |
| Submerging of Telegraph Cables, America | 602             |
| "    "    European.....                 | 610             |
| Submarine Telegraph Cables.....         | 607             |
| "    "    "    Atlantic.....            | 623             |
| "    "    "    Balize.....              | 617             |
| "    "    "    Black Sea.....           | 618             |
| "    "    "    Dover & Calais.....      | 608             |
| "    "    "    Danish Baltic            |                 |
| "    "    "    Sea.....                 | 616             |
| "    "    "    Dover, and O-            |                 |
| "    "    "    tend.....                | 613             |
| "    "    "    England and              |                 |
| "    "    "    Holland.....             | 614             |
| "    "    "    Holyhead.....            | 609             |
| "    "    "    Irish Chan-              |                 |
| "    "    "    nel.....                 | 612, 614        |
| "    "    "    Mediterranean            |                 |
| "    "    "    618.....                 | 618             |
| "    "    "    Portpatrick.....         | 614             |
| "    "    "    Prince Edward's          |                 |
| "    "    "    Island.....              | 616             |
| "    "    "    Zuyder Zee... ..         | 617             |
| Subterranean Telegraphs.....            | 587             |
| Swedish Wire, Strength of.....          | 521             |
| Schweigger's Multiplier.....            | 116             |
| Swain, Wm. M., Biographical Sketch of   | 822             |
| Swain's Insulator.....                  | 537             |
| "    Improvement of Battery Tumbler     | 101             |
| Tariff of Charges, American.....        | 758             |
| "    "    French.....                   | 770             |
| "    "    Russian.....                  | 782             |
| "    "    International.....            | 784             |
| Tanner, Wm., Biographical Sketch of..   | 825             |
| Telegraph, The.....                     | 17              |
| "    Derivation of.....                 | 17              |
| "    Applied Meaning of.....            | 17              |
| "    Early History of.....              | 17              |
| "    Divine.....                        | 18              |
| "    of the Classics.....               | 19              |
| "    Polybius'.....                     | 20              |
| "    Agamemnon's.....                   | 21              |
| "    American Aboriginal.....           | 24              |
| "    "    Revolutionary.....            | 26              |
| "    Semaphoric.....                    | 27              |
| "    Atlantic, Projected.....           | 665             |
| "    "    Company.....                  | 622             |
| "    American Electro-magnetic          |                 |
| "    Alexander's.....                   | 139             |
| "    Bain's Printing.....               | 269             |
| "    "    Chemical.....                 | 354             |
| "    Baron Schelling's.....             | 135             |
| "    Bakewell's Copying.....            | 304             |
| "    Brett's Printing.....              | 273             |
| "    Bell Apparatus.....                | 346             |
| "    Circuits of Morse.....             | 480             |
| "    Conductors.....                    | 513             |
| "    Cooke's Electrometer.....          | 179             |
| "    Companies, Origin of.....          | 748             |
| "    Davy's Electric.....               | 255             |
| "    Early Electric.....                | 132             |
| "    English Electrometer.....          | 216             |
| "    "    Stations.....                 | 238             |
| "    Electrometers, how made.....       | 122             |
| "    French State.....                  | 325             |
| "    "    Railway.....                  | 834             |
| "    Froment's.....                     | 873             |
| "    Gauss and Weber's.....             | 137             |
| "    Henry's Magnetic.....              | 299             |

|                                          | PAGE.    |                                            | PAGE.    |
|------------------------------------------|----------|--------------------------------------------|----------|
| Telegraph, Highton's Electric.....       | 286      | Variation of Magnetic Needle.....          | 106      |
| " House's Printing.....                  | 391      | Velocity of Electric Currents, Sub-        |          |
| " Insulation.....                        | 529      | aqueous.....                               | 503-7-12 |
| " Improved Apparatus of.....             | 718      | Vitreous Electricity.....                  | 53       |
| " Lomond's.....                          | 132      | Voltaic Electricity.....                   | 77       |
| " Morse's, Invented.....                 | 402      | " Currents explained.....                  | 493      |
| " " Chemical.....                        | 366      | " Quantity and Intensity of.....           | 493      |
| " Magneto-electric.....                  | 286      | " Circuits, Composed of.....               | 517      |
| " Magnets, How Made.....                 | 120      | " Pile.....                                | 79       |
| " Nott's Electric.....                   | 310      | " and Magnetic Electricity.....            | 283      |
| " Poles.....                             | 672      | Wade, Telegraph Insulator.....             | 548      |
| " Reizen's.....                          | 133      | " J. H., Biographical Sketch of.....       | 831      |
| " Ronald's.....                          | 147      | " Submarine Cable.....                     | 600      |
| " River Crossings on Masts.....          | 657      | Walker's, Charles V., Insulator.....       | 532      |
| " Salva's.....                           | 135      | Washburn and Co.'s Telegraph Wire... 519   |          |
| " Subterranean.....                      | 587      | Watson's Experiments.....                  | 488      |
| " Seimens and Halskie's.....             | 313      | Westbrook and Rogers' Chemical Tele-       |          |
| " Smith and Bain's.....                  | 364      | graph.....                                 | 370      |
| " Soemmering's.....                      | 142      | Weber and Gauss' Telegraph.....            | 137      |
| " Submarine, American.....               | 599      | Weason's, W. D., Telegraph Improvement 733 |          |
| " " European.....                        | 607      | Wire Joints, Telegraphic.....              | 704      |
| " Type, Morse's.....                     | 404      | " Suspension of.....                       | 677      |
| " At Siege of Troy.....                  | 21       | " Conductibility of.....                   | 515      |
| " Truetler's, Semaphoric.....            | 50       | " Strength of.....                         | 519      |
| " Tunbridge Station.....                 | 335      | Wheatstone's Mechanical Telegraph... 209   |          |
| " Wire Joints.....                       | 704      | " and Cook, partners.....                  | 193      |
| " Wires, Strength of.....                | 519      | " Permutating Key-board... 192             |          |
| " " Conductibility of.....               | 515      | Working of Atlantic Cable.....             | 635      |
| " " Suspension of.....                   | 677      | Wollaston's Improvement on Batteries.. 90  |          |
| " Wheatstone's.....                      | 209      | Woodman and Farmer's Telegraph Im-         |          |
| " Westbrook and Rogers'.....             | 307      | provement.....                             | 736      |
| Telegraphing by Sound.....               | 467, 839 | Wooden Shield Insulator.....               | 548      |
| Tightening Wires.....                    | 659      | Writing Telegraph, Morse's.....            | 409      |
| Time Ball, Electric.....                 | 741      | " " Froment's.....                         | 373      |
| Time for Poles.....                      | 681      | Yandell's Telegraph Insulator.....         | 543      |
| Trees falling on the Telegraph.....      | 679, 710 | Zinc-coated Telegraph Wires.....           | 516      |
| Vail's, Alfred, Experiments of.....      | 488      | Znyder Zee Cable.....                      | 617      |
| " Printing Telegraph.....                | 382      |                                            |          |
| Varley's, C. F., Experiments on Atlantic |          |                                            |          |
| Cable.....                               | 637      |                                            |          |



RETURN TO the circulation desk of any

University of California Library

or to the

NORTHERN REGIONAL LIBRARY FACILITY

Bldg. 400, Richmond Field Station

University of California

Richmond, CA 94804-4698

ALL BOOKS MAY BE RECALLED AFTER 7 DAYS

2-month loans may be renewed by calling

(510) 642-6753

1-year loans may be recharged by bringing books  
to NRLF

Renewals and recharges may be made 4 days  
prior to due date

DUE AS STAMPED BELOW

APR 29 1995

RETURNED

JUL 27 1994

Santa Cruz Jitney

MAR 05 2008

MAY 18 2008

20,000 (4/94)



YC 19543

U.C. BERKELEY LIBRARIES



C006769276

7677

TK5261

S5

UNIVERSITY OF CALIFORNIA LIBRARY



