This is a reproduction of a library book that was digitized by Google as part of an ongoing effort to preserve the information in books and make it universally accessible.

Google™ books

<https://books.google.com>



STORAGE

M2E5

The HISTORY *of the*
INCANDESCENT
LAMP



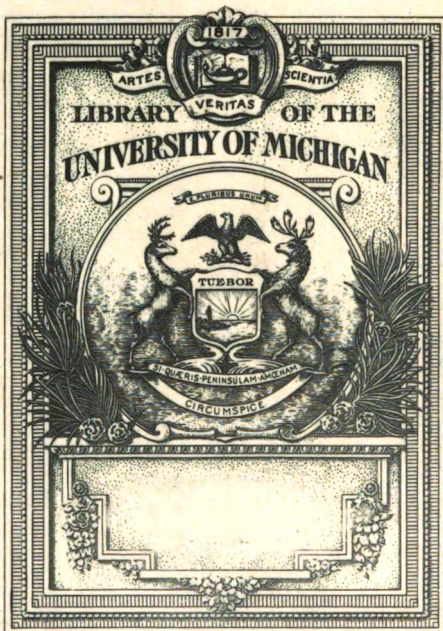

THE GIFT OF
The Author

TK
4351
.H86

HISTORY OF THE INCANDESCENT LAMP

By
JOHN W. HOWELL
AND
HENRY SCHROEDER

THE MAQUA COMPANY, *Publishers*
SCHENECTADY, NEW YORK

1927

Copyright, 1927, by
The Maqua Company



Printed in the
United States of America
Published 1927

Authors
gift
8-8-1927

CONTENTS

	PAGE
INTRODUCTION	4
CHAPTER ONE—Development of Electric Lighting Prior to Edison's Invention	7
CHAPTER TWO—Edison's Invention of a Practical Incandescent Lamp, a Complete Lighting System and Their Commercial Introduction	45
CHAPTER THREE—Development of Filaments	75
CHAPTER FOUR—The Vacuum, "Getters" and the Gas Filled Lamp	123
CHAPTER FIVE—Leading-in Wire Developments	155
CHAPTER SIX—Glass Construction	163
CHAPTER SEVEN—The Base	182
CHAPTER EIGHT—Photometry	193
Index	206

INTRODUCTION

The Incandescent Electric Lamp as made and patented by Mr. Edison, is the foundation stone upon which the great electric light and power industry of today has been built. The great electric companies which were organized in the early 80's,—the Edison Electric Illuminating Companies, as they were generally known, in New York, Boston, Philadelphia, Chicago and in many other places—were organized to light their territories with the Edison incandescent lamp. This was practically the only business or source of revenue that these companies had, since electric motors were not well developed and came slowly into use.

When Mr. Edison started to make a lamp factory at Menlo Park, in the fall of 1880, he started an entirely new industry. He could get no tools, machinery, or experience from other industries, therefore they all had to be created, designed, and built from experience as he went along. Lamps were still more or less of a mystery, and the simple laws relating to them were not well understood. Electrical instruments were home made, as no suitable ones could be purchased. The Harrison lamp factory was wired with bare wire, stapled on the wood beams, and no cut-outs or switches were available. An Archimedes screw pump for raising the mercury used in exhausting lamps was the only piece of machinery used in the Menlo Park lamp factory, except the blower used by the glass blowers and in the carbonizing room.

Constant experimenting was done to determine the relative advantages of different ways of performing the various operations, and it was a long time before definite methods were settled upon. These methods were frequently changed as more experience was accumulated.

Many lamps were burned on life test from the very beginning, to determine the relative value of the various experiments. This constant experimenting and testing made the work most interesting.

During the first year or two, Mr. Edison spent a good deal of time at the factory, and had a laboratory there. His presence and leadership were a great inspiration to all, so that time meant nothing to those who were helping him to carry out his work or experiments.

As the various methods of manufacture became settled, it became possible to organize the factory operations and to adopt piece work methods; but it was a long time before any lamp making machinery enabled the substitution of unskilled labor for the skilled glass workers. It is hard for anyone who sees the modern lamp factory to realize the work done in developing the art to its present degree of perfection.

The lamp is apparently very simple, but its design, manufacture, and development require quite a broad knowledge of physics and chemistry. This has attracted many bright-minded men to the industry, who have found it a most interesting field of work.

The growth of the business, from the invention of the lamp to the present day, has all taken place during the working lives of some of the men still in the business. This history of the lamp has been written in order to portray the changes and developments which brought it to its present high state of perfection and efficiency.

JOHN W. HOWELL
HENRY SCHROEDER

March, 25, 1927.

CHAPTER ONE

DEVELOPMENT OF ELECTRIC LIGHTING PRIOR TO EDISON'S INVENTION

The word electricity originates from the Greek name for amber, "elektron;" Thales, a Greek philosopher having recorded the fact about twenty-five centuries ago that if amber is rubbed it will attract objects of light weight. About two hundred and fifty years later Aristotle, another Greek philosopher, found that a mineral, later called lodestone and now known to be the iron ore magnetite, would attract iron. The word magnet comes from the fact that lodestones were first found near Magnesia, a city in Asia Minor. The word lodestone, an abbreviation for "leading stone," comes from the fact, probably discovered by sailors in the northern countries of Europe, although it has been often credited to the Chinese, that this mineral would point to the north if suspended like a compass.

William Gilbert, physician to Queen Elizabeth of England, made a number of experiments, among which was the discovery of magnetic lines of force, and of north and south poles in a magnet. He wrote a book about the year 1600 summarizing the then known facts about electricity and magnetism. A few years previously Robert Norman had discovered that the amount of dip of the compass needle varied at different points on the sphere. From this he deduced that the earth was a magnet and assumed that the magnetic and geographic north poles were the same. It has since been found that these poles do not coincide. Gilbert also discovered that many substances beside amber would also attract light objects if rubbed.

Otto Von Guericke, about 1650, made a machine consisting of a ball of sulphur mounted on a shaft which could be rotated. Electricity was generated when the shaft was

THE INCANDESCENT LAMP

rotated and the hand lightly pressed against the rotating sulphur ball. He also discovered that the electricity generated could be conducted away from the sulphur ball by a metal chain from which sparks could be obtained. Francis Hawksbee, about sixty years later, made a similar machine, using a hollow glass globe from which the air had been exhausted by the vacuum pump that had been

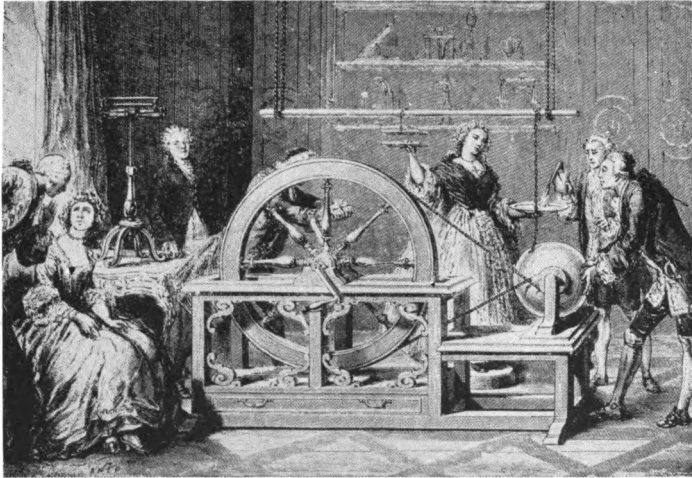

OTTO VON GUERICKE'S ELECTRIC MACHINE, 1650.
Electricity was generated by friction between the hand and the rotating sulphur ball.

invented by Von Guericke. This exhausted globe when rotated at high speed and rubbed against the hand produced a glow of light. This electric light, as it was called, created a great excitement when it was shown before the Royal Society, a gathering of English scientists. Those machines were forerunners of the frictional glass disc machines which generate electricity at very high pressures

THE INCANDESCENT LAMP

(but in very small quantities) so that long sparks can be produced. They are now occasionally used for medical purposes.

Stephen Gray, about 1729, demonstrated before the Royal Society that electricity could be conducted about a thousand feet by a hemp thread. This was possible if the hemp thread was supported by silk thread but could not be done if metal supports were used. Charles duFay, in 1733, showed that those substances, which Gilbert had found could be electrified if rubbed, were insulators; and those substances which could not be electrified were conductors of electricity.

Von Kleist, about 1745, invented the so-called Leyden jar, the forerunner of the present condenser, in attempting to store electricity. The name came from the fact that it was independently discovered shortly afterward by experimenters in the University of Leyden. Von Kleist, knowing that the frictional machines generated so small a quantity of electricity, thought he could store it in a glass bottle full of water, as water was known to be a conductor and glass an insulator. In the bottle was a cork with a nail through it, the nail touching the water inside. Holding the bottle in one hand and turning a frictional machine with the other, the machine being connected to the nail in the cork, he proceeded to fill the bottle with electricity. After turning the machine for a few moments he pulled the bottle away from it and then touched the nail with his hand. The shock threw him down and nearly stunned him. Later it was found that the hand holding the bottle was as essential as the water inside, both being later replaced by tin foil.

Benjamin Franklin made numerous experiments with the Leyden jar. He connected several jars in parallel and produced a discharge strong enough to kill a fowl. He also connected jars in series (in "cascade" he called it), thereby establishing the principle of parallel and series connections. Franklin's most famous experiment is his proof that lightning is electricity. This he did in 1752, by

THE INCANDESCENT LAMP

flying a kite in a thunderstorm, and drawing electricity from the clouds with which he charged Leyden jars and drew sparks from a key attached to the kite string. It is a wonder that he was not killed by this experiment. These experiments led to his invention of the lightning rod.

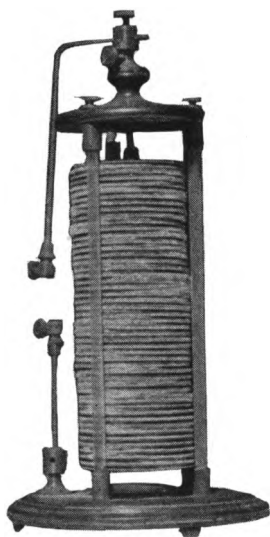

VOLTAIC PILE, 1799

Volta discovered the principle of the present day primary battery, one form of which is the so-called dry battery used for flashlights and in radio. This was the first time that electricity could be obtained in considerable quantity and the volt is named after him in honor of this discovery. Photograph, courtesy of Charles F. Chandler Museum, Columbia University, New York.

Volta's Invention of the Primary Battery

About 1785, so it is said, the wife of Luigi Galvani, an Italian scientist, was in delicate health. Some frogs' legs were being skinned to make her a nourishing soup. Galvani's assistant, holding the legs with a metal clamp and cutting the skin with a scalpel, happened to let the clamp

THE INCANDESCENT LAMP

and scalpel touch each other. To his amazement the frogs' legs twitched. Galvani repeated the experiment and proposed a theory of animal electricity in a paper he published in 1791.

Alessandro Volta, a professor of physics at the University of Pavia in Italy, repeated Galvani's experiments and found that the clamp and scalpel must be of different metals. He believed that the electric charge which made the muscles in the frogs' legs convulse was caused by the action of the moisture in the muscles on the different metals. Following up this idea, he made a pile of silver and zinc discs, probably coins, with pieces of cloth wet with salt water between them. From this Voltaic Pile, as it was called, he found that electricity could be obtained. In March, 1800, he sent a letter to the Royal Society in London, describing his invention, and the **VOLT**, the unit of electrical pressure, was named after him in honor of this discovery.

It was later shown that the chemical affinity of one of the metals for the liquid was converted into electrical energy. In Volta's Pile the zinc combines chemically with the salt water when a wire is connected to the silver and zinc terminals, forming zinc chloride, caustic soda and hydrogen gas.

A more powerful battery was made by the use of copper, zinc and dilute sulphuric acid. The zinc combining with the sulphuric acid forms zinc sulphate and hydrogen gas. The latter appears as bubbles on the copper plate and reduces the voltage of the battery, this being called "polarization." Minute impurities in the zinc will cause the zinc to be attacked even when the circuit is open, as the impurities form a local short circuited cell. This is called "local action," and in order to prevent the zinc from being uselessly consumed, it was removed from the dilute acid when the battery was not in use. Later it was found that this difficulty could be largely overcome if the zinc electrode were rubbed with a little mercury, so that its surface became amalgamated.

THE INCANDESCENT LAMP

Improvements in Batteries

The main difficulty with the copper-zinc-sulphuric acid battery was the formation of hydrogen gas bubbles on the copper electrode (polarization) which greatly reduced its operating voltage, and it was found that if the bubbles were removed, by brushing them off with a stick of wood for instance, the capacity of the battery would be greatly increased.

In 1836, John Frederic Daniell, an English chemist, invented a chemical means of overcoming this difficulty. He made a battery consisting of an amalgamated zinc rod in dilute sulphuric acid, as in the previous batteries. These were placed in a porous earthenware jar which was put in a saturated solution of copper sulphate. Thus the dilute sulphuric acid was kept physically separate from the copper sulphate solution, but the two liquids were in electrical contact with each other through the pores of the porous cup.

The other electrode was copper and was immersed in the copper sulphate solution. The chemical action of the battery was that the zinc combining with the sulphuric acid formed zinc sulphate and hydrogen gas as before. The hydrogen gas going through the pores of the cup combined with the copper sulphate, forming sulphuric acid and metallic copper, the latter being deposited on the copper electrode. Crystals of copper sulphate were kept in the copper sulphate solution to maintain it in a saturated condition. Later the porous cup was dispensed with, the two solutions being kept apart by their difference in specific gravity. This was called the gravity battery, and for many years was used in telegraphy. The voltage of this battery was about one volt per cell.

Sir William Robert Grove made a notable further improvement in batteries. It was known that the electrical energy of the zinc-sulphuric acid cell came from the chemical affinity of the two, and that if the hydrogen gas set free could be combined with oxygen to form water, such additional chemical affinity would increase the strength of the cell.

THE INCANDESCENT LAMP

Nitric acid was known to be a very active oxidizing agent, but as it attacks copper, platinum was substituted as the material for the positive electrode, where the hydrogen gas bubbles appear.

In 1840 Sir Robert made a battery consisting of a platinum electrode in strong nitric acid which was kept in the inner porous jar to prevent it from attacking the zinc electrode. This combination was put in dilute sulphuric acid containing the amalgamated zinc rod electrode. The hydrogen gas, liberated by the action of the sulphuric acid on the zinc, combined with the nitric acid to form nitrous peroxide and water. Part of the nitrous peroxide dissolved in the water and the rest escaped in the form of very suffocating fumes. This battery had almost double the strength of previous batteries, having a voltage of about 1.9 volts.

Some years later Grenet improved the battery by substituting a solution of potassium bichromate for the nitric acid. This solution could be mixed directly with the sulphuric acid, as it does not attack zinc to a great extent. The porous jar was, therefore, unnecessary and no fumes were formed. To lessen the cost, a slab of carbon was used for the positive electrode. The zinc electrode was fastened to a sliding rod so that it could be drawn up into the neck of the bottle shaped jar containing the liquid, to prevent the useless consumption of zinc when the battery was not in use.

The Ampere

André Marie Ampère was a professor of mathematics in the Polytechnic School in Paris. In 1820 Oersted, a professor of physics in the University of Copenhagen in Denmark, had announced his accidental discovery that current flowing in a wire would deflect a compass from its true position. Ampère repeated Oersted's experiments and made a number of others from which he developed several fundamental laws regarding current flowing in a wire. He also discovered that current flowing in a coil of wire gave it the properties of a magnet, and thus established

THE INCANDESCENT LAMP

the long sought connection between electricity and magnetism. The AMPERE, the unit of flow of electric current, was named for him in honor of his discoveries.

Ohm's Law

About the most important fundamental law of electricity was discovered in 1825, by Georg Simon Ohm, a teacher in the High School in Cologne. It was known that the rate of transfer of heat from one end of a metal bar to the other was in proportion to the difference in temperature between the ends. By analogy and experiment, Ohm found that the current in a wire is proportional to the difference of voltage (electric pressure) between the ends of the wire. He also showed that the current in the wire is inversely proportional to the electrical resistance of the wire. With these as a basis, Ohm propounded the law that the current flowing in a circuit is equal to the voltage divided by the resistance. In honor of this discovery, the OHM, the unit of electrical resistance, was named after him.

As often happens in such cases, critics derided this law, and in this case the criticism was so severe that Ohm was forced out of his position in the High School. Having been born of parents in poor circumstances, and worked his way through college in order to obtain an education, he keenly felt the criticism which forced him to give up the sort of work for which he had so earnestly striven. He went back to his parents and worked in his father's blacksmith shop for over ten years. Finally he began to find supporters to his theory and in 1841 his law was publicly recognized by the Royal Society in London, which presented him with the Copley medal.

This simple law is at first difficult to understand, but if once mastered will solve many electrical problems. It is usually expressed as:

$$C = \frac{E}{R}$$

“C” meaning Current (in amperes)

“E” meaning Electromotive Force (in volts)

“R” meaning Resistance (in ohms)

THE INCANDESCENT LAMP

If two of the factors in the above formula are known, the third can be readily determined. For example, an incandescent lamp, burning on a circuit whose voltage (pressure) is known to be 120, is found to consume $\frac{1}{2}$ an ampere of current. The electrical resistance of such a lamp is therefore 240 ohms.

Perhaps the simplest analogy to an electrical circuit is a hydraulic system. The voltage in an electrical system is similar to the pounds per square inch pressure in the hydraulic system. The amperes flowing in an electric circuit are similar to the gallons per minute of water flowing in a pipe; it is the *rate* of flow, not the actual volume. This is often the stumbling block to the uninitiated. Another term similar to the ampere is rate of speed, which is usually expressed in miles per hour. The difference between a *rate* and an actual *volume* may be shown, for example, by the size of an automobile storage battery which is expressed in ampere-hours; that is, a 120 ampere-hour battery is one which has the capacity to deliver 15 amperes continuously for eight hours. Similarly a 120 gallon tank will deliver 15 gallons of water per minute for eight minutes; or an automobile traveling fifteen miles per hour will take eight hours to cover 120 miles.

The resistance of an electrical circuit is generally quite easy to understand. It is similar to the friction that water encounters in flowing through a pipe. A large pipe will allow water to flow through it quite easily, and therefore, has a low resistance in the same sense that a large wire has a low electric resistance.

The Invention of the Dynamo

Schweigger, familiar with Oersted's and Ampère's discoveries, invented the galvanometer (or "multiplier" as he called it) which consists of a compass needle suspended within a coil of wire. Current flowing in the coil deflects the needle, the amount of deflection indicating the strength of the current. This made available a very sensitive electrical measuring instrument.

THE INCANDESCENT LAMP

Sturgeon had also shown that if a bar of iron were placed in a coil of wire the magnetic strength of the coil would be greatly increased. This he called an electro-magnet.

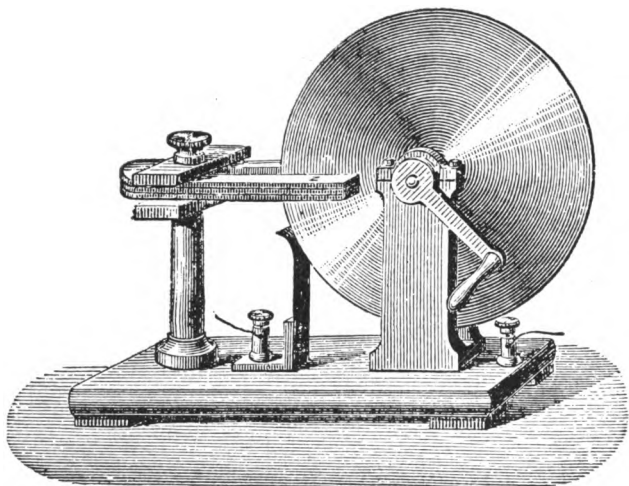

FARADAY'S DYNAMO, 1831

Michael Faraday invented the dynamo, the foundation of the electric light and power industry. The dynamo, however, did not become commercially practicable until about forty years later.

Michael Faraday, born of English parents in poor circumstances, became a bookbinder and so was enabled to study books on electricity and chemistry. His desire to become a scientist was so great that he finally induced Sir Humphry Davy to give him a position as his laboratory assistant. He aided Davy in his lectures and experiments and also made a number of experiments himself. As a result of his own research work, he was elected to a Fellowship in the Royal Society in 1824.

THE INCANDESCENT LAMP

Faraday then began a number of electrical experiments in an endeavor to find further relation between electricity and magnetism. Ampère having converted electricity into magnetism, Faraday tried to find out if the reverse were possible. Finally, in the latter part of 1831, he made the experiment of moving a permanent magnet in and out of a coil of wire connected to a galvanometer. This generated electricity in the coil and the galvanometer needle was deflected. He then made a machine consisting of a copper disc mounted on a shaft so that the disc could be rotated between the poles of a permanent horseshoe magnet. A copper brush rubbed against the edge of the disc as it rotated. A galvanometer was connected by wires to this brush and to the shaft so that when the disc was rotated by hand, the current generated deflected the galvanometer needle.

Faraday, being satisfied with pure research work, did not develop his discovery any further, so that it remained for others to make it practicable. It was not, however, until many years later that the dynamo became commercial, and as it is the foundation of the electric light industry, its development is of great importance.

The next year, 1832, Hippolyte Pixii, a Frenchman, going back to Faraday's original experiment of moving a permanent magnet in the neighborhood of a coil of wire, and using Sturgeon's scheme of strengthening the magnetism in the coil of wire by a piece of iron, invented a dynamo that was quite an advance over Faraday's disc machine. It consisted of a permanent horseshoe magnet, the ends of which were rotated about the ends of two coils of wire mounted on a soft iron core. A commutator changed the direction of the alternating current generated so that direct current was obtained. This machine had a very small capacity, about equal to that of the present day standard dry cell used for an electric bell. It was only a laboratory toy, but many of the principles of the present day dynamos were embodied in it. Pixii obtained a U.S. patent on his machine in 1832.

THE INCANDESCENT LAMP

In 1834, E. M. Clarke, an Englishman, made several dynamos, the principles of which were the same as those of Pixii's except that he rotated the coils of wire alongside the poles of a stationary permanent horseshoe magnet.

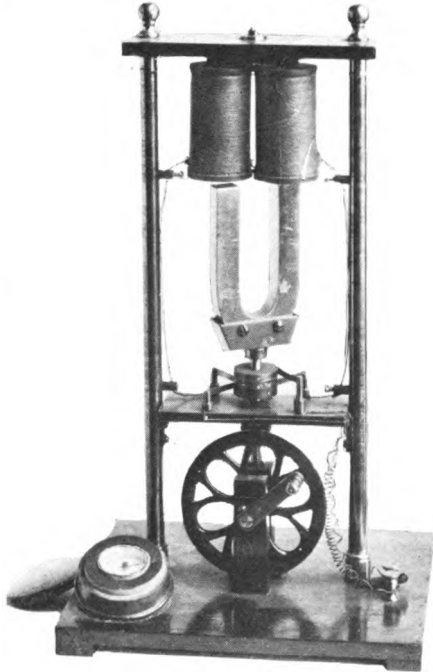

PIXII'S DYNAMO, 1832

Hippolyte Pixii made a dynamo which was quite an advance. A permanent magnet rotated in the neighborhood of two coils of wire mounted on an iron core, the alternating current generated being rectified by a commutator. This is a photograph of the Patent Office model which is on exhibition at the United States National Museum, Washington, D. C., through whose courtesy the picture is shown.

Pixii's and Clarke's dynamos produced a pulsating direct current which was made unidirectional by means of a commutator. While this means that they delivered direct

THE INCANDESCENT LAMP

current, their voltage (pressure) was pulsating. In 1841 Woolrich devised a machine which had several magnets and double the number of coils, which reduced the pulsations. Wheatstone, in 1845, patented the use of electro-magnets in place of permanent magnets. Brett, in 1848,

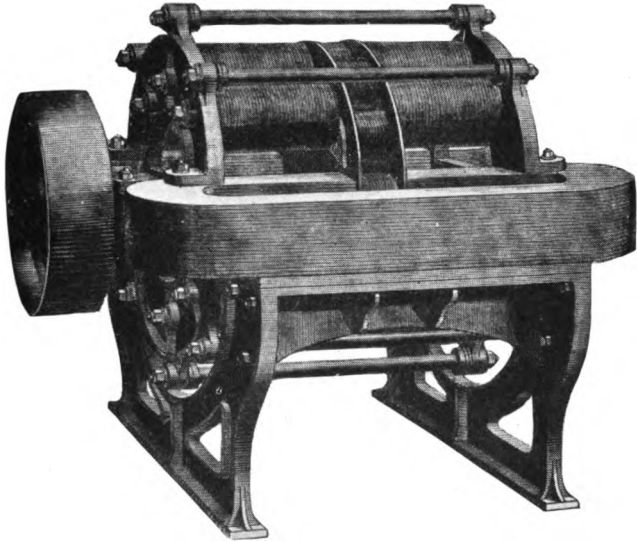

HJORTH'S DYNAMO, 1855

This may be called the first "self-excited" machine, having permanent magnet field poles inducing current in the armature which energized the electro-magnet fields. It was not used commercially.

suggested that the current given by a permanent magnet machine be made to flow through coils surrounding the permanent magnets to further strengthen them and thereby increase the output of the machine.

About this time it was discovered that the iron surrounded by the wire coils became heated due to currents being generated in the iron itself while moving through the magnetic field of the magnets. Such currents are called eddy

THE INCANDESCENT LAMP

currents, and in 1849 Pulvermacher proposed that the iron be made into thin sheets to reduce them. All dynamos now have a laminated sheet iron armature core.

In 1851, Sinstenden suggested that the current obtained from a permanent magnet machine be used as a

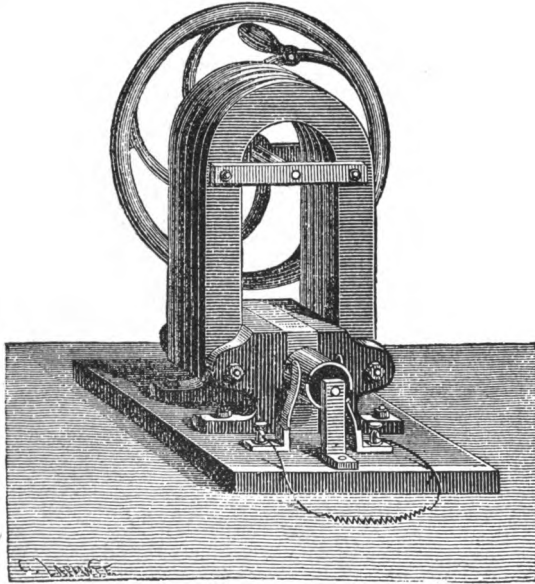

SIEMENS' DYNAMO, 1856

Dr. Werner Siemens countersunk the armature wires in an iron core, making a cylindrical shaped armature. This revolved between magnet poles shaped to fit the armature, reducing the air gap and so making a more powerful machine.

source of excitation to supply current to the field coils of an electro-magnet machine. This scheme, though no permanent magnet machines are now made, is generally used in all large electric power stations, a separate machine being used to supply current for the field coils of the large dynamos.

THE INCANDESCENT LAMP

In 1855, Hjorth patented a dynamo having both permanent and electro-magnet field poles. The current, first induced in the armature by the permanent magnets, energized the electro-magnet field poles. This, therefore, may be said to be the first "self-excited" electro-magnet machine. It was not commercially used.

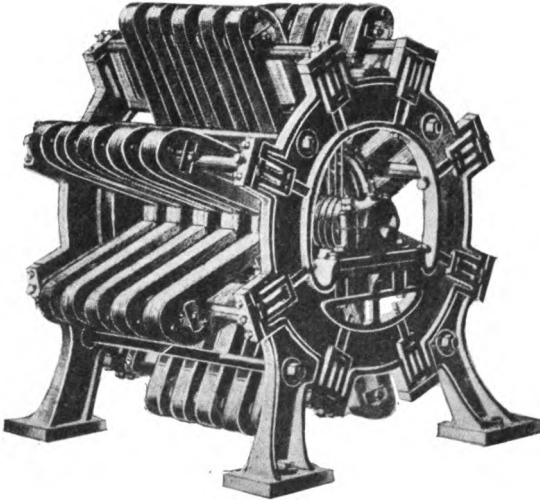

ALLIANCE DYNAMO, 1862

This machine was designed by Nollet for the commercial manufacture of illuminating gas by decomposing water electrically. This project failed, but in 1862 the machine was used to supply current to the first commercial use of an electric light, an arc lamp in the Dungeness Lighthouse in England.

Dr. Werner Siemens greatly improved the dynamo by his invention, in 1856, of the shuttle wound armature. The armature coil was countersunk in an iron core so as to make a cylindrical armature which fitted closely between the poles, which were shaped to enclose it. This greatly reduced the air gap between the armature and field poles

THE INCANDESCENT LAMP

and thereby greatly increased the number of the magnetic lines of force passing through the armature. This arrangement, in principle, is used in all dynamos made today.

Another interesting dynamo is that designed in 1850, by Nollet, a professor of physics at the Brussels Military School. This dynamo had several rows of permanent

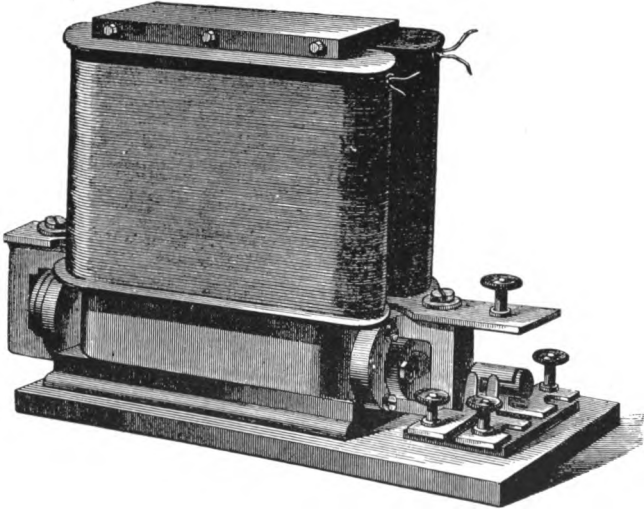

WHEATSTONE'S DYNAMO, 1866

This was the first self excited dynamo using the residual magnetism in the field poles.

magnets mounted radially on a stationary frame, the armature consisting of wire bobbins mounted on a shaft which rotated within the frame. A commutator was used so that direct current could be obtained. A company was organized to supply hydrogen gas enriched with oils for illuminating gas, the hydrogen gas to be made by the decomposition of water with current from this machine.

Nollet died and the company failed. About ten years later it was reorganized as the Alliance Company to exploit

THE INCANDESCENT LAMP

the arc lamp, which at that time (1860) had been fairly well developed. Difficulties were experienced with the commutator of the dynamo, so it was removed and collector rings substituted, the machine then delivering alternating current. A trial installation of the arc light was then made in the Dungeness Lighthouse in England, the installation being formally accepted in 1862.

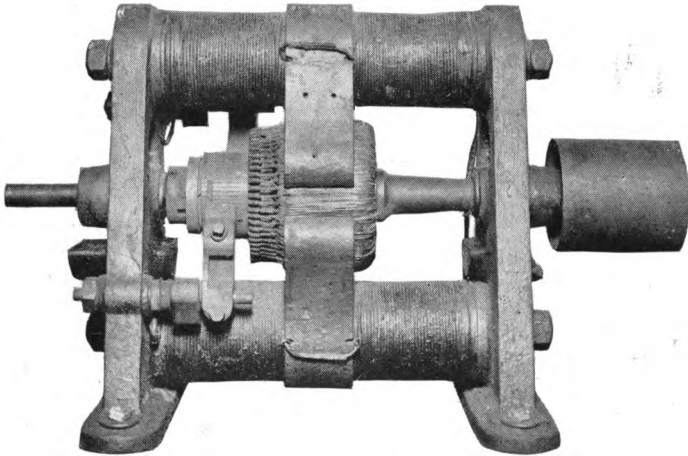

GRAMME'S DYNAMO, 1871

Its main feature was the "ring" wound armature. Several of these machines were used in commercial service for arc lighting purposes. This dynamo is in the historical collection of the Association of Edison Illuminating Companies in conjunction with the Edison Pioneers by whose courtesy this photograph is reproduced.

This was the first commercial installation of an electric light, an arc lamp. The Alliance dynamo had a capacity for one arc lamp, which probably consumed about ten amperes at about 45 volts, and as the dynamo was very inefficient, it probably required at least one and a half horse power to drive it.

Sir Charles Wheatstone is credited with the invention of the first self-excited machine which operated on the principle of utilizing the residual magnetism in

THE INCANDESCENT LAMP

the field poles to set up a feeble current in the armature, which, passing through the field coils, gradually increases their strength until they are built up to normal. He built a machine in the summer of 1886, and exhibited it before the Royal Society at a meeting held in February, 1867. A paper describing the machine was read at this meeting. Another paper, for-

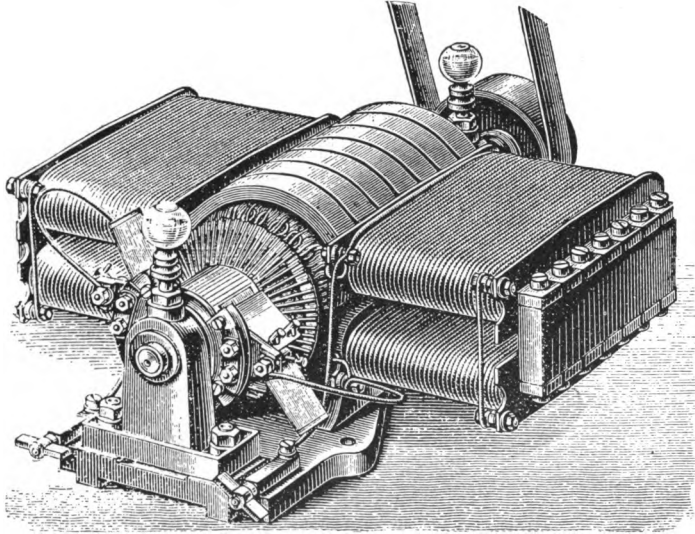

ALTENECK'S DYNAMO, 1872

The armature was "drum" wound, that is, the wires were wound on the surface of the armature. This construction is used in all dynamos made to this day.

warded by Dr. Werner Siemens, was also read at the same meeting describing a similar machine invented by him. Wheatstone probably preceded Siemens in this invention.

In 1870 Gramme, a Frenchman, made a dynamo having a "ring" wound armature. The armature consisted of a ring shaped core of iron wire which was coated with an insulating compound to reduce the eddy currents.

THE INCANDESCENT LAMP

The core was wound with insulated copper wire coils, all connected in series as one single endless coil, each coil being tapped with a wire connected to a commutator bar. The first machine built with electro-magnet fields was made in 1871, and many of these were later built for commercial arc lighting installations.

Alteneck, an engineer with Siemens, in 1872, invented the "drum" wound armature. The wires were all on the surface of the armature core, being tapped at frequent points for connection with the commutator bars. This method of construction is used in all dynamos now made.

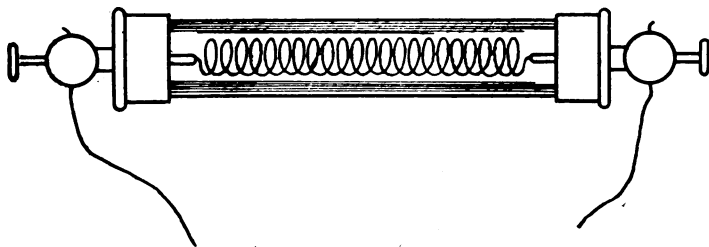

DE LA RUE'S INCANDESCENT LAMP, 1820

In this lamp, the first one on record, a platinum wire operated in vacuum.

Davy's Discovery of Electric Light

Sir Humphry Davy was a well known English chemist. About 1802, with the aid of a powerful battery that he had constructed, he made a number of experiments on the chemical effects of electricity. He decomposed a number of substances and discovered several elements, among which were boron, potassium and sodium. He gave several lectures before the Royal Society and incidentally demonstrated that electricity would heat thin strips of metal to a white heat, causing them to oxidize so rapidly in the air that they literally burned up. Platinum, he found, would not oxidize as readily, so that it could be heated to a white heat and give light for a considerable length of time. This

THE INCANDESCENT LAMP

was the forerunner of the incandescent lamp, but it was not until 1879 that a lamp suitable for general distribution was invented.

About 1809, Davy also demonstrated the arc light. This he did with a battery of two thousand cells, the terminals of which were connected to two charcoal sticks. A brilliant arch shaped flame was produced when the two charcoal

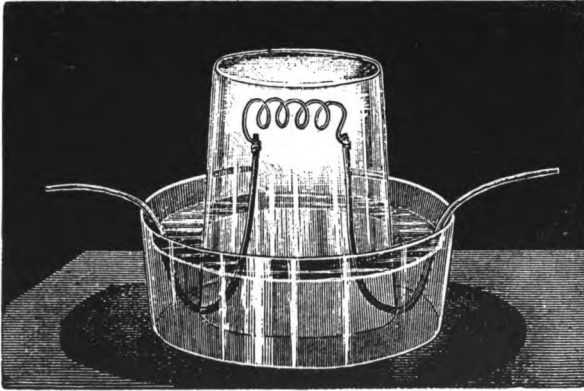

GROVES' INCANDESCENT LAMP, 1840

A coiled platinum wire burner was covered by a glass tumbler surrounded by water in glass dish to protect the burner from draughts of air.

sticks were allowed to touch each other and then pulled apart, the name "arc" being given to this light on account of the shape of the flame.

The First Attempts at Making an Incandescent Lamp

The earliest record of any attempt at making an incandescent lamp was in 1820, when De la Rue made a lamp with a coil of platinum wire for a burner which was enclosed in a piece of glass tubing, the ends of which had brass caps. It was supposed to have had a vacuum, but how this was accomplished is not clear.

THE INCANDESCENT LAMP

Platinum has to operate very close to its melting temperature before it becomes incandescent. At this operating temperature it disintegrates rapidly, so that such a lamp would not last long. The cost of current from the batteries then available made its operating cost prohibitive, so the lamp is of historic interest only.

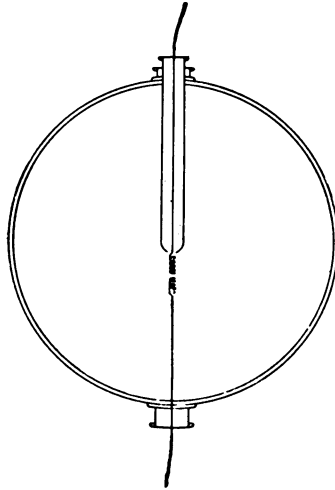

DE MOLEYN'S INCANDESCENT LAMP, 1841

This lamp is of interest as being the first one on which a patent (British) was granted. The lamp contained powdered charcoal which filled and bridged the gap between two coils of platinum wire mounted in a globe from which the air had been exhausted.

In 1840, Grove gave a lecture before the Royal Society and demonstrated his battery by lighting the auditorium with incandescent electric light. His lamps consisted of a coil of platinum wire fastened to the ends of copper wires, the lower part of which were varnished for insulation. The platinum wire burner was covered by a glass tumbler to protect it from draughts of air, which would otherwise cool it. The open end of the tumbler was set in a glass dish

THE INCANDESCENT LAMP

partly filled with water through which the varnished copper wires extended, and which thereby made a seal preventing any draught of air from reaching the burner.

The platinum had to be operated very close to its melting point before it became sufficiently incandescent to give any

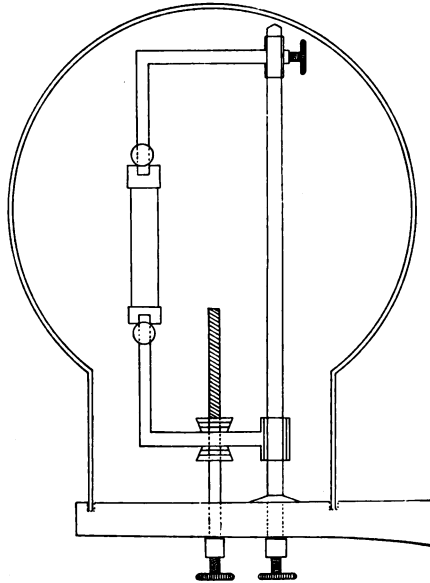

STARR'S PLATINUM LAMP, 1845

This lamp had a strip of platinum for a burner whose active length was adjustable to fit the size of battery used. It operated in air but was covered by a globe to protect the burner from draughts.

light. A great deal of current was also required to keep the platinum incandescent as the air in the tumbler tended to cool it by conducting the heat away. It is estimated that the cost of current with Grove's battery was at the rate of several hundred dollars a kilowatt-hour. As a comparison, the present general average retail rate at which current is

THE INCANDESCENT LAMP

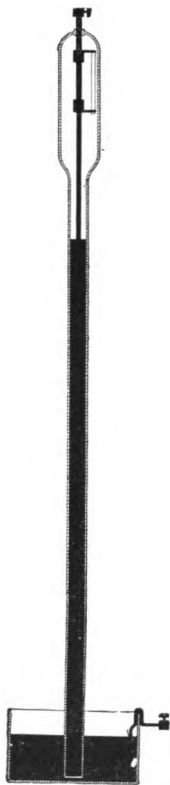

STARR'S CARBON LAMP, 1845

This consisted of a rod of carbon operating in the vacuum above a column of mercury.

sold by central station lighting companies is now about eight cents a kilowatt-hour.

The first patent on an incandescent lamp was granted by the British Government in 1841 to Frederick De Moleyns. His lamp was quite novel, consisting of a spherical glass globe in the upper part of which was a glass tube

THE INCANDESCENT LAMP

containing powdered charcoal. This tube was open at the bottom and through it ran a platinum wire coiled at the end inside the globe. Another platinum wire extended upward from the bottom of the globe, terminating in a coil whose end was close to that of the first coil. The powdered charcoal in the glass tube filled the two coils

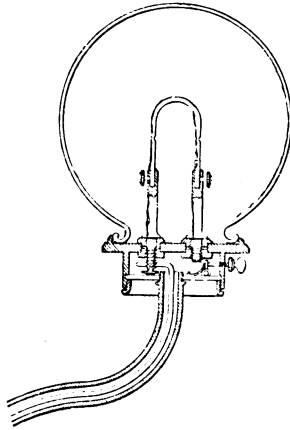

STAITE'S LAMP, 1848

The burner was of platinum and iridium operating in air but covered by a globe.

of platinum wire, bridging the gap between them. Current flowing from one platinum wire to the other through the bridge of powdered charcoal made the latter incandescent.

Starr's Contribution to Incandescent Lamp Development

J. W. Starr was an American from Cincinnati, Ohio, who induced George Peabody, the philanthropist, to back him in his research work. He went to England and in 1845 obtained a patent on two incandescent lamps he had invented. This patent was taken out under the name of King, his attorney.

THE INCANDESCENT LAMP

One lamp consisted of a strip of platinum, the active length of which could be adjusted to fit the strength of the battery used so that the burner would operate at the proper temperature. It was covered by a glass globe to protect it from draughts of air.

Starr's other lamp consisted of a carbon rod operating in the vacuum above a column of mercury (Torrecellium vacuum) as in a barometer. A platinum wire was sealed in the upper end of a tubular glass bulb, inside of which was a thin slab of carbon attached to the platinum wire by an iron clamp. The lower end of the carbon slab was attached by another iron clamp to a long copper wire. Fused to the bottom end of the tubular glass bulb was a narrow glass tube, open at the end, and a little over thirty inches in length, into which the copper wire extended. The bulb with its extended glass tube was filled with mercury and set in a dish containing mercury after the fashion of a mercury barometer, so that the mercury ran out of the bulb and came to rest in the tube at about 30 inches above the surface of mercury in the dish.

This lamp, however, was impractical, as it is now known that such a vacuum contains water vapor, and that when the lamp is lighted, the heat will drive gases out of the glass, the carbon rod, iron clamps, etc., which will cause it to blacken rapidly.

Unfortunately, Starr died on board ship, while returning to the United States in the following year (1846). He was only 25 years old.

Other Experimental Incandescent Lamps

During the next few years, several inventors tried to make incandescent lamps, even though it was known that their use with current obtained from batteries would be impractical. The dynamo was being improved but was still impractical commercially.

In 1848, W. E. Staite made a lamp having a burner consisting of platinum and iridium operating in the air, but covered by a glass globe to protect it from draughts. It

THE INCANDESCENT LAMP

had a thumb screw for a switch, the whole device being mounted on a bracket, the arm of which was to be the return wire.

Edward C. Shepard, in 1850, made a lamp consisting of a weighted charcoal cylinder pressing against a charcoal cone in vacuum. The high resistance contact became incandescent when current flowed through it.

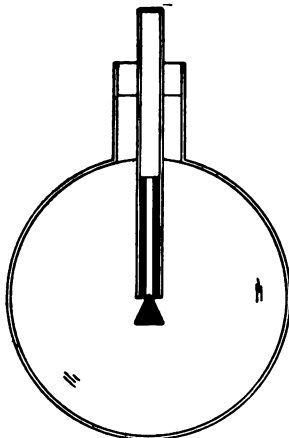

SHEPARD'S LAMP, 1850

The high resistance contact between a weighted charcoal cylinder pressing against a charcoal cone in vacuum made the charcoal incandescent.

M. J. Roberts, in 1852, made a lamp having a graphite rod operating in vacuum. The open end of the glass globe surrounding the burner was cemented to a metal cap, to which was screwed a pipe containing a stop cock. Through this pipe the air could be exhausted, the stop cock closed, and the lamp then mounted on a stand. The graphite rod was held by a clamp at the end of two metal rods, one rod being fastened to the pipe and the other being insulated from but passing through the metal cap. The lamp was not successful because such an arrangement could not maintain a good vacuum for any length of time.

THE INCANDESCENT LAMP

In 1856, De Changy, a French civil engineer, obtained a Belgian patent on a lamp having a coiled platinum wire for the burner which operated in air but was covered by a glass tube to protect it from draughts. It was a portable

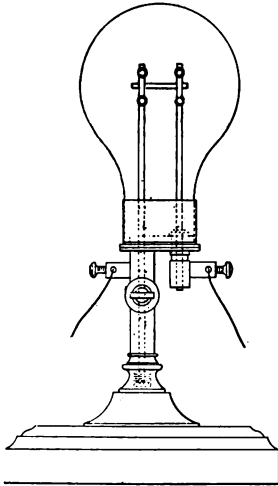

ROBERTS' LAMP, 1852
This consisted of a graphite rod operating in vacuum.

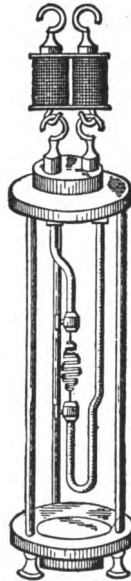

DE CHANGY'S LAMP, 1856
This had a platinum burner operating in air but covered by a glass tube. It was designed for use in a mine, being so arranged that it could be hooked to wires fastened on the walls throughout the mine and thus be located in the places desired.

affair having hooks for terminals, and was intended specially for use in mines. A pair of wires could be fastened to the walls and run throughout the mine; the lamp could be located in different places as desired by simply hooking it to the wires.

THE INCANDESCENT LAMP

Professor Moses G. Farmer, of the Naval Training Station at Newport, Rhode Island, made a lamp in 1859, several of which were used to light the parlor of his home, 11 Pearl Street, Salem, Mass., during July of that year. The lamp consisted simply of a strip of sheet platinum operating in air, the novel feature being that the strip was narrower at the ends than in the middle. This caused it to be more uniformly incandescent throughout its entire length,

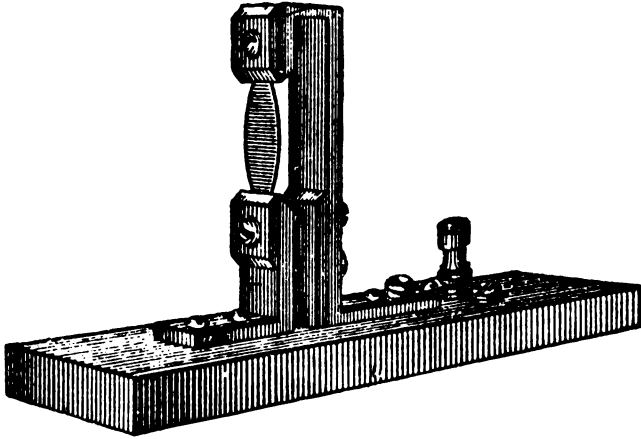

FARMER'S LAMP, 1859

Prof. Farmer, during July, 1859, lighted the parlor of his home at Salem, Mass., with several of these lamps. The platinum burner was narrowed at its ends so that the entire length became more uniformly incandescent.

the higher resistance of the narrowed ends consuming proportionally more electrical energy, and thus offsetting the loss of heat which was conducted away by the terminals of the lamp. He obtained a U.S. patent on this feature many years later, (1882).

Swan's Contributions

Sir Joseph W. Swan, who became one of the foremost incandescent lamp manufacturers in England, made at various times, from 1848 to 1860, a number of experimental

THE INCANDESCENT LAMP

lamps. These consisted of carbonized strips and spirals of paper and cardboard, coated with various liquids, which on being heated left a large residue of carbon. These lamps were operated in vacuum, either in a glass bottle having a wide neck closed with a rubber stopper through which the connecting wires passed, or in a glass bell whose rim made a tight fit within the rim of a brass plate through which one insulated connecting wire passed, the plate being used

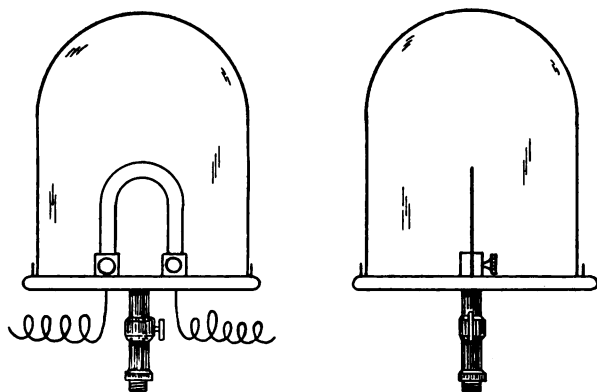

SWAN'S LAMP, 1860.

A strip of carbonized paper was covered by a glass bell fitting tight on a brass plate and operated in vacuum.

as the other connection. Owing partly to some trace of air being left within the glass container, and partly to the carbons becoming distorted, the lamps soon broke down.

The pumps used to produce a vacuum consisted of a plunger operating in a cylinder with valves. This produced a relatively very poor vacuum compared with that now possible. In 1865, Herman Sprengel, by his invention of the mercury vacuum pump, had been able to get a vacuum far superior to any previously attainable. This pump consisted of a long glass tube held vertically, the bottom end being dipped into mercury in a container. The upper end had two branches, one connected to a supply of mercury

THE INCANDESCENT LAMP

and the other to the device from which the air was to be exhausted. The mercury, in flowing down the tube, trapped bubbles of air, the weight of the mercury forcing these air bubbles down the tube and out into the outside atmosphere. Thus in time the flow of mercury would exhaust the air from the device.

In 1875, Crookes (afterwards Sir William Crookes), astonished the world by the exhibition of his radiometer and the description of the improved means he employed, in connection with the Sprengel pump, for obtaining the near approach to a perfect vacuum which the construction of the radiometer demanded. The publication of this paper led Sir Joseph Swan to resume his incandescent lamp experiments.

In 1877, Swan, through a chance advertisement about radiometers, got a young bank clerk, Charles H. Stearn, to assist him in carrying out these experiments. Stearn had been pursuing investigations which required high vacuum and was familiar with the manipulative requirements necessary for obtaining a very high degree of evacuation.

A series of experiments were started by Stearn with carbon conductors of various forms and sizes, which Swan supplied, beginning with the strips and spirals of carbonized paper and cardboard formerly used, and which Swan had firmly fixed in his mind, would be durable when operated to incandescence in a very perfect vacuum. These were mounted in glass bulbs which were exhausted to the highest possible degree by means of the Sprengel pump.

Great difficulty was at first experienced in making firm contact between the ends of the carbon strip and the conducting wires to which it was held. To avoid the manipulative difficulties and to arrive more rapidly at a definite settlement of the question whether and under what conditions a carbon conductor would be durable, the thin strips and spirals were, for the time being, discarded and other forms of carbon conductors were tried. Among the forms used were carbon wires, both straight and bent in an arch, made of the same plastic material commonly used in carbon rods for arc lamps.

THE INCANDESCENT LAMP

Notwithstanding the fact that the lamp bulb had been highly evacuated, the vacuum rapidly deteriorated owing to the evolution of gases from the carbon which took place as soon as current was turned on. This difficulty was overcome by heating the bulb by a flame from the outside and then passing a strong current through the carbon to make

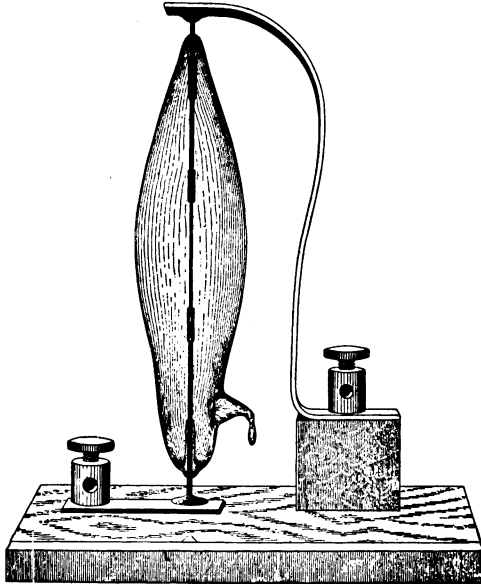

SWAN'S LAMP, 1878

A carbon wire operated in a high vacuum in an all-glass globe.

it brilliantly incandescent while it was still connected to the exhaust pump. The straight carbon wires were found to buckle and so did not last, but the arch shaped carbon wires gave good results.

When the incandescent lamp became commercially available, Swan invented, early in 1880, the parchmentized thread which, when carbonized, produced a long thin

THE INCANDESCENT LAMP

carbon that was used by some manufacturers for many years. He discovered that cotton thread treated with sulphuric acid became agglutinated and lost its fibrous condition, having the appearance and the hardness of cat-gut when dried. This material could even be planed and scraped down to a fine wire of the most perfect roundness and could be bent into spirals which retained their shape during carbonization. The difficulty previously experienced

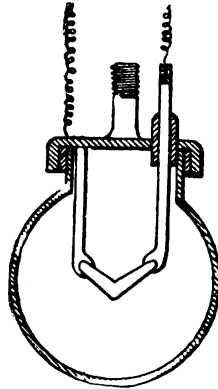

LODYGUINE'S LAMP, 1872

This had a graphite burner operating in nitrogen gas. An experimental installation of two hundred of these lamps was made to light the Admiralty Dockyard at St. Petersburg.

in making firm contact between the ends of the fine carbon and the conducting wires was overcome by making enlarged ends on the carbons which were held in tiny silver or copper sockets, similar to that of a crayon holder, and secured with a slip ring. Later on improved means were devised for making good electrical contact by means of a contrivance developed by Swan and Gimmingham which consisted in tubulating the ends of the conducting wires, inserting the ends of the carbons in the tubes and causing a deposit of carbon to take place at the junction.

THE INCANDESCENT LAMP

Russian Incandescent Lamp Inventors

In 1872, Lodyguine, a Russian scientist, made a lamp having a "V" shaped piece of graphite for a burner which operated in nitrogen gas. This was covered by a glass globe fastened to a metallic cap with a gasket to make a tight

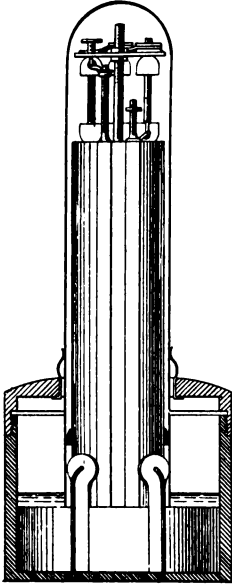

KOSLOFF'S LAMP, 1875

This had several graphite rods, one operating at a time. When one burned out, another was automatically connected. The rods operated in nitrogen gas.

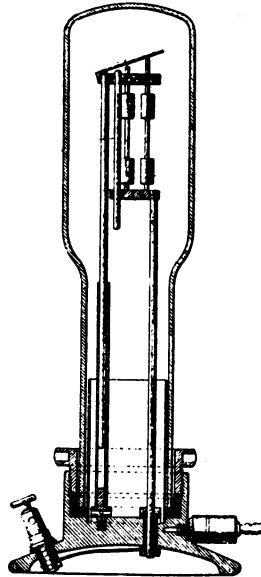

KONN'S LAMP, 1875

This lamp was similar to that of Kosloff's except that the graphite rods operated in vacuum.

joint. He installed two hundred of these lamps about the Admiralty Dockyard at St. Petersburg. In 1874 the Russian Academy of Sciences awarded him the Lomonossov Prize of fifty thousand rubles, then worth about \$25,000, for his invention. A company was formed with a capitalization of

THE INCANDESCENT LAMP

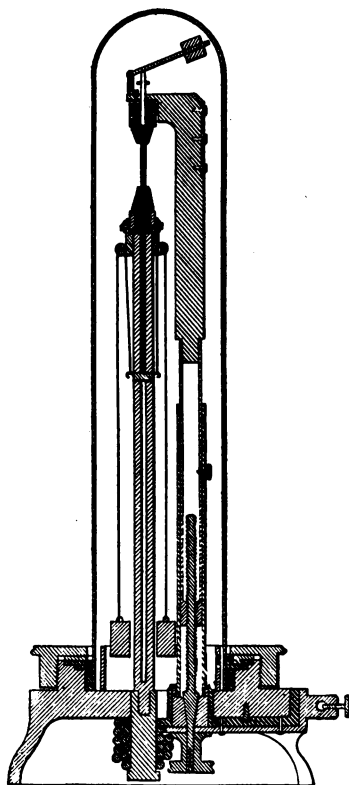

BOULIGUINE'S LAMP, 1876

This had a long graphite rod operating in vacuum. Only the upper part of the rod was in circuit and as this part burned out, the rod was automatically shoved up, thus placing a fresh portion in circuit.

200,000 rubles to exploit the lamp, but the project soon failed as the lamp was too expensive to operate.

In 1875, Kosloff, another Russian, made a lamp consisting of several graphite rods operating in nitrogen. The rods were so arranged that only one operated at a time

THE INCANDESCENT LAMP

and, when it burned out, another was automatically connected in circuit. Konn, also a Russian, invented a lamp in 1875, similar to that of Kosloff, except that the graphite rods operated in vacuum. The next year, 1876, Bouliguine, another Russian, made a lamp having a long graphite rod, only the upper part of which was in circuit. When this part burned out, a counterweight automatically pushed the rod upward thereby placing a fresh portion of the long rod in circuit. It operated in vacuum.

Commercial Introduction of the Arc Lamp

None of these incandescent lamps was practical; they had short lives, were expensive to operate, were unreliable in their operation, and so were not commercially used. By this time, however, the arc lamp was being introduced commercially, the pioneer installation being that of Jablochhoff, who lit the boulevards in Paris with his "electric candle." This simple arc lamp consisted of two carbon rods held together side by side and insulated from each other by kaolin. The kaolin vaporized as the carbons were consumed, giving the arc a peculiar color. A complete system was developed by Jablochhoff, consisting of an alternating-current generator, having a stationary exterior armature with internally revolving field poles. Alternating current was used to offset the difficulty experienced with the unequal consumption of the carbons on direct current. A series system of distribution was used and, in order to prevent interruption of the circuit should one "candle" go out, several candles were put in each fixture with an automatic device to connect a fresh candle whenever one burned out.

In the United States there were several pioneer arc light systems. The earliest were those of William Wallace, of Ansonia, Connecticut, who became associated with Prof. Moses G. Farmer; Edward Weston, of Newark, New Jersey, the well known maker of electrical measuring instruments; Charles F. Brush, of Cleveland, Ohio; and Prof. Elihu Thomson, who became associated with Edwin J. Houston.

THE INCANDESCENT LAMP

and formed the Thomson-Houston Company, a fore runner of the General Electric Company.

Thus, in 1877, the arc lamp was commercially established, dynamo electric machines were available, and a demand had arisen for a smaller electric light than the arc lamp.

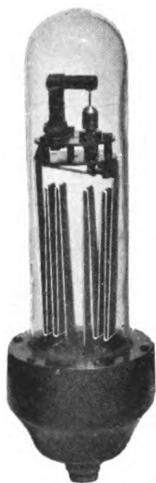

SAWYER'S LAMP, 1878

This was one of several developed, all having a graphite burner operating in nitrogen gas. The heavy fluted copper wires were used to radiate the heat and thus maintain a cool joint between the glass cover and metal holder.

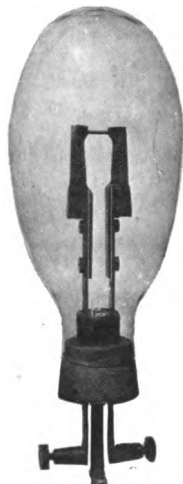

FARMER'S LAMP, 1878

This also had a graphite rod operating in nitrogen gas. This lamp is on exhibit at the United States National Museum at Washington, D.C., through whose courtesy this photograph is shown.

"Subdividing the Electric Light"

In this country there were four men who were energetically attacking the problem, popularly called "subdividing the electric light," the arc lamp being the only then known electric light. This phrase was really a misnomer, because the arc lamp was not subdivided into small units, a practical incandescent lamp being the final result of the experiments. These four men were: William E. Sawyer, Prof. Moses G. Farmer, Hiram S. Maxim, and Thomas A. Edison.

THE INCANDESCENT LAMP

Sawyer became associated with Albon Man, his patent attorney, who gave him financial assistance. The Sawyer-Man Electric Company was organized and several lamps were developed. They all consisted of a piece of graphite operating in nitrogen, covered by a glass globe cemented to

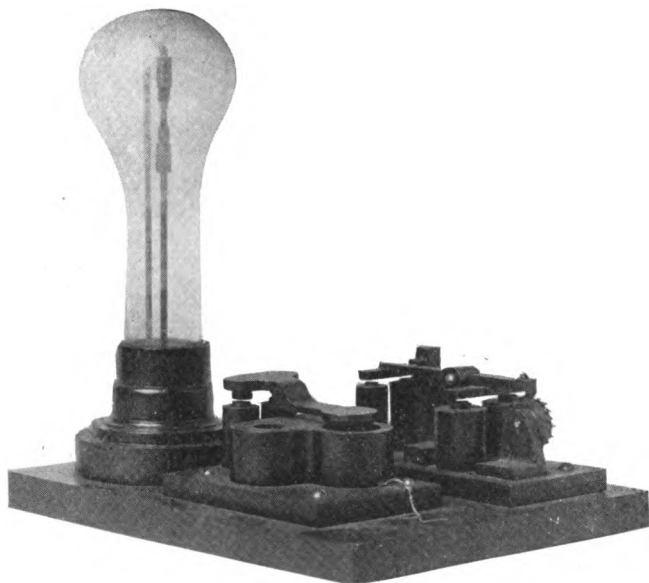

MAXIM'S GRAPHITE LAMP, 1878.

A graphite rod operated in a rarefied hydro-carbon vapor. An electromagnet short circuited the burner when the current became too strong. This lamp is also on exhibit at the United States National Museum, through whose courtesy this photograph is shown.

a metal holder. Heavy fluted copper wires were used to make connections with the burner through the holder, in order to radiate the heat and thereby maintain a cool joint between the glass globe and holder. The lamps were designed so that they could be renewed by opening the

THE INCANDESCENT LAMP

joint and putting in a fresh burner. The company failed, but was later reorganized after Edison's invention of a practical lamp. This company was a forerunner of the present Westinghouse Lamp Company.

Farmer made a lamp consisting of a graphite rod which also operated in nitrogen gas. It was covered by a glass bulb having a rubber stopper through which copper rods connecting with the burner were passed. A tube was put in the rubber stopper through which the air was exhausted and nitrogen gas put in.

Maxim, well known for his later invention of the rapid fire gun, made two lamps. One consisted of a piece of sheet platinum operating in air. The main feature of this lamp was that when the platinum, held at the top by an adjustable bolt and nut, became too hot and dangerously near its melting temperature it would expand sufficiently to make contact with a wire which short circuited the burner. This shunted the current from the platinum burner, allowing it to cool for a fraction of a second so that it shrank, opening the short circuit and allowing current to flow again through the burner. The other lamp consisted of a graphite rod operating in a rarefied hydrocarbon vapor and protected from excessive current by an electro-magnet which short circuited the graphite burner.

CHAPTER TWO

EDISON'S INVENTION OF A PRACTICAL INCANDESCENT LAMP, AND A COMPLETE LIGHTING SYSTEM, AND THEIR COMMERCIAL INTRODUCTION

Edison first began his study of the incandescent lamp problem in the fall of 1877. He had a well equipped laboratory at Menlo Park, New Jersey, with several able assistants and many workmen, about a hundred people all told. He had already made several important inventions, among which were; the quadruplex telegraph, whereby four messages could be sent simultaneously over one telegraph wire, thereby quadrupling the capacity of the telegraph lines of the country; the carbon telephone transmitter, without which Bell's telephone receiver would have been impracticable; and the phonograph. The lasting value of these inventions proved that Edison was eminently fitted to attack the problem of "subdividing the electric light."

Edison first made many experiments with the object of confirming the failures of others. In July, 1878, his health having been undermined by his unceasing work, he took a trip with an expedition to Wyoming to observe an eclipse of the sun. This he called a "vacation", but he brought with him a delicate instrument he had invented which he called a tasimeter. This was devised to measure the heat transmitted through great distances. In about two months he returned to Menlo Park and again studied the lamp problem, which was but one among many others he was trying to solve.

His first experiments having shown the seeming impracticability of carbon for the incandescent burner, he started investigating platinum. He developed a lamp hav-

THE INCANDESCENT LAMP

joint and putting in a fresh burner. The company failed, but was later reorganized after Edison's invention of a practical lamp. This company was a forerunner of the present Westinghouse Lamp Company.

Farmer made a lamp consisting of a graphite rod which also operated in nitrogen gas. It was covered by a glass bulb having a rubber stopper through which copper rods connecting with the burner were passed. A tube was put in the rubber stopper through which the air was exhausted and nitrogen gas put in.

Maxim, well known for his later invention of the rapid fire gun, made two lamps. One consisted of a piece of sheet platinum operating in air. The main feature of this lamp was that when the platinum, held at the top by an adjustable bolt and nut, became too hot and dangerously near its melting temperature it would expand sufficiently to make contact with a wire which short circuited the burner. This shunted the current from the platinum burner, allowing it to cool for a fraction of a second so that it shrunk, opening the short circuit and allowing current to flow again through the burner. The other lamp consisted of a graphite rod operating in a rarefied hydrocarbon vapor and protected from excessive current by an electro-magnet which short circuited the graphite burner.

CHAPTER TWO

EDISON'S INVENTION OF A PRACTICAL INCANDESCENT LAMP, AND A COMPLETE LIGHTING SYSTEM, AND THEIR COMMERCIAL INTRODUCTION

Edison first began his study of the incandescent lamp problem in the fall of 1877. He had a well equipped laboratory at Menlo Park, New Jersey, with several able assistants and many workmen, about a hundred people all told. He had already made several important inventions, among which were; the quadruplex telegraph, whereby four messages could be sent simultaneously over one telegraph wire, thereby quadrupling the capacity of the telegraph lines of the country; the carbon telephone transmitter, without which Bell's telephone receiver would have been impracticable; and the phonograph. The lasting value of these inventions proved that Edison was eminently fitted to attack the problem of "subdividing the electric light."

Edison first made many experiments with the object of confirming the failures of others. In July, 1878, his health having been undermined by his unceasing work, he took a trip with an expedition to Wyoming to observe an eclipse of the sun. This he called a "vacation", but he brought with him a delicate instrument he had invented which he called a tasimeter. This was devised to measure the heat transmitted through great distances. In about two months he returned to Menlo Park and again studied the lamp problem, which was but one among many others he was trying to solve.

His first experiments having shown the seeming impracticability of carbon for the incandescent burner, he started investigating platinum. He developed a lamp hav-

THE INCANDESCENT LAMP



EDISON'S MENLO PARK BUILDINGS

On the left is the wooden laboratory building, in the left background is the brick machine shop. The brick building in the right foreground is the office and library.



EDISON AND SOME OF HIS CO-WORKERS

The men are assembled on the front of the laboratory building. They are, from left to right—top row: J. W. Lawson, unknown, unknown, L. K. Boehm, Charles Batchelor, Francis Jehl, F. R. Upton, and Dr. A. Haid; second row: J. F. Kelly, David Cunningham, T. A. Edison, Major F. McLaughlin and T. Logan; third row: J. F. Randolph, Charles Flammer, George Dean, George E. Carman, John F. Ott, James Seymour and unknown; bottom row: A. Swanson, Martin N. Force, S. L. Griffin, and Milo Andrus.

THE INCANDESCENT LAMP

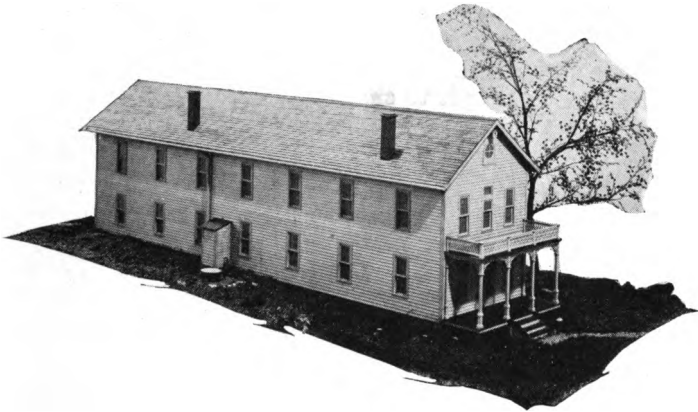

MODEL OF EDISON'S LABORATORY BUILDING

This model was made by F. A. Wardlaw, one of Edison's early associates. Each part of the model is made from the original parts of the building itself down to the last detail; the shingles, clapboards, piazza railing and posts, flooring, bricks in the chimney, etc., and even the glass in the windows. Photograph courtesy of the Association of Edison Pioneers.



INTERIOR OF EDISON'S LABORATORY BUILDING, 1880

This photograph was taken February 22, 1880. Several lamps will be seen mounted on the converted gas fixtures hanging from the ceiling. Edison is seated in about the center, his principal assistants gathered about him.

THE INCANDESCENT LAMP



EDISON'S MENLO PARK BUILDINGS

On the left is the wooden laboratory building, in the left background is the brick machine shop. The brick building in the right foreground is the office and library.



EDISON AND SOME OF HIS CO-WORKERS

The men are assembled on the front of the laboratory building. They are, from left to right—top row: J. W. Lawson, unknown, unknown, L. K. Boehm, Charles Batchelor, Francis Jehl, F. R. Upton, and Dr. A. Haid; second row: J. F. Kelly, David Cunningham, T. A. Edison, Major F. McLaughlin and T. Logan; third row: J. F. Randolph, Charles Flammer, George Dean, George E. Carman, John F. Ott, James Seymour and unknown; bottom row: A. Swanson, Martin N. Force, S. L. Griffin, and Milo Andrus.

THE INCANDESCENT LAMP

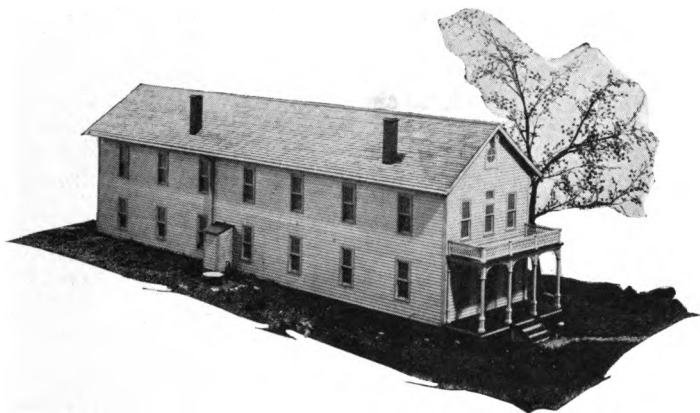

MODEL OF EDISON'S LABORATORY BUILDING

This model was made by F. A. Wardlaw, one of Edison's early associates. Each part of the model is made from the original parts of the building itself down to the last detail; the shingles, clapboards, piazza railing and posts, flooring, bricks in the chimney, etc., and even the glass in the windows. Photograph courtesy of the Association of Edison Pioneers.



INTERIOR OF EDISON'S LABORATORY BUILDING, 1880

This photograph was taken February 22, 1880. Several lamps will be seen mounted on the converted gas fixtures hanging from the ceiling. Edison is seated in about the center, his principal assistants gathered about him.

THE INCANDESCENT LAMP

ing a platinum spiral for a burner. Inside the spiral was a rod which expanded when the platinum became heated, and if the temperature became too high, the expansion of the rod would cause it to short circuit the burner, thereby allowing the platinum to cool. This took but a fraction of a second, and the rod, contracting almost immediately, opened the short circuit. Thus the lamp only "blinked"

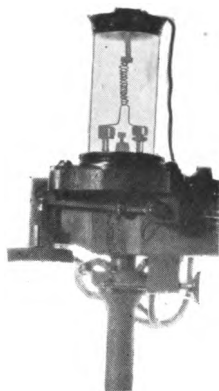

EDISON'S FIRST PLATINUM LAMP, 1878

This was the first of a number of lamps he built in his study of making a practical incandescent lamp. It is in the William J. Hammer Collection of Historical Incandescent lamps. Photograph, courtesy of Major Hammer and the Association of Edison Illuminating Companies, in whose custody this collection is kept.

when the current was too high. A patent was applied for in October, 1878, and Edison's first lamp patent was granted in April, 1879.

Up to this time Edison had spent quite a lot of money in lamp research, and, in order to raise more money to continue the work, a corporation was organized. On October 17, 1878, the Edison Electric Light Company, with a capital of \$300,000, was incorporated by several prominent men for the purpose of backing Edison in his

THE INCANDESCENT LAMP

work of trying to develop a complete incandescent electric light system. This company was a forerunner of the present General Electric Company.

Edison's next step in lamp research was to make a more sensitive thermostatic arrangement to short circuit the platinum burner. This was accomplished by means of an expanding diaphragm, a patent being applied for in November, 1878, and granted early the next year. He then made a lamp using platinum foil for the burner. A patent was applied for on this lamp in December, 1878, and granted in August of the following year.

His next development was a lamp having an inverted "U" shaped burner consisting of finely divided iridium mixed with oxide of zirconium. The latter is a non-conductor of electricity when cold, but iridium made the composite burner a conductor and, when heated, the zirconium oxide also became a conductor. A patent on this was applied for in December, 1878, and granted in September, 1879.

Edison's next application for a lamp patent was made in February, 1879, and covered a long carbon rod pressed upward by a heavy counterweight against a platinum-iridium rod. The light was obtained from the current heating the resistance of the poor contact between the rods. As the heat consumed the end of the carbon rod, it was automatically fed upward by the counterweight. The platinum-iridium rod was also slowly consumed. A patent for this lamp was granted in February, 1880.

Edison's Study of a Complete Incandescent Lighting System

None of the lamps he had made was practical and furthermore he realized that even if he was finally able to make a lamp that would be commercial, it would be impractical if operated on the series system of distributing electricity, as it would be impossible to turn on or shut off one lamp without doing the same thing to all the others on the circuit. In this system the current is constant throughout the circuit,

THE INCANDESCENT LAMP

the current flows out of the armature of the dynamo through one brush, through the field coils, through one lamp after another and then back to the armature through the other armature brush. This system was satisfactory for arc lamps, which are inherently a constant current device, and was also suitable for use in street lighting for which arc lamps were most generally used, as in that case there was no need to turn on one lamp at a time.

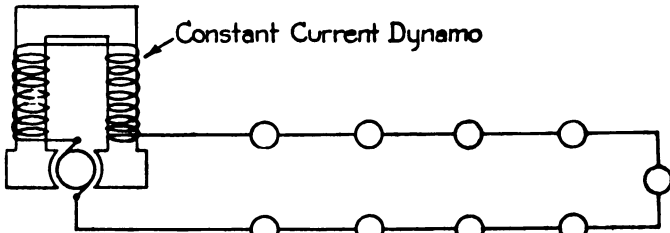

DIAGRAM OF CONSTANT CURRENT SYSTEM

Prior to 1878, this was the only known method of distributing electric current.

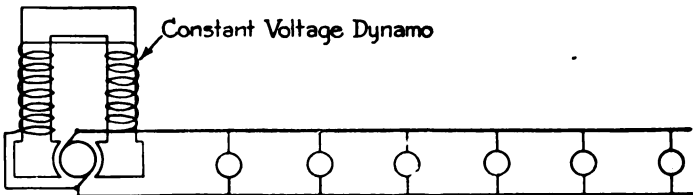

DIAGRAM OF EDISON'S MULTIPLE SYSTEM

In 1878, Edison invented this system of distributing electricity at a constant pressure and in quantities as required. It is now universally used.

Edison therefore reasoned that another system of distributing electricity to lamps must be used, patterned after the existing gas light system, as small electric lamps would find their greatest usefulness in household, commercial, and industrial lighting. He made an intensive study of gas, obtaining all the literature possible on the subject, and spending several weeks of his time in continuous reading.

THE INCANDESCENT LAMP

Gas is distributed through pipes, with mains, feeders and branches supplying it at about constant pressure at the lamps. While the gas escapes into the air after it is burned, electric current must be returned to the dynamo armature after it goes through the lamps.

After much thinking he evolved a constant pressure electrical system, which is called the "multiple" system of distribution. In this system current is generated at a constant pressure and supplied in quantities as desired.

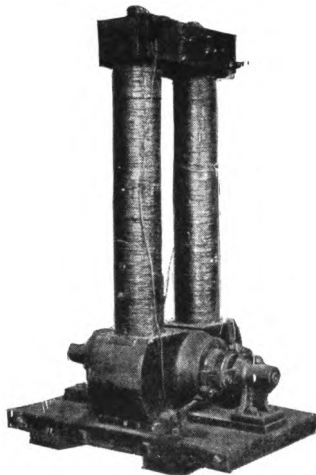

EDISON'S CONSTANT VOLTAGE DYNAMO.

This machine was invented by Edison to fit the multiple system he had also invented. It had an efficiency of 90 per cent which scientists had mathematically "proved" was impossible.

This required the design of a dynamo to supply such a current. This was something that had not been previously done, but undaunted, he attacked the problem.

After much intensive study, he designed a dynamo having an extremely low resistance in the armature. He made a drum wound armature, using large heavy wires in place of small ones in order to reduce the resistance. The

THE INCANDESCENT LAMP

field coils were connected directly across the armature in multiple, instead of in series with it. When the machine was run at a certain constant speed, the voltage (pressure) between the two armature brushes was approximately 110 volts and remained about constant, falling but slightly with increasing amounts of current taken from the machine. Up to a certain point, the capacity of the machine, this could be done without undue heating of the armature. He found by tests that the machine, at about full load, converted 90 per cent of the mechanical energy required to drive it into electrical energy, or in other words, it was 90 per cent efficient.

When he announced the invention of this dynamo, some scientists ridiculed it, as it had been proven that the greatest amount of electrical power which could be obtained from a battery was at that point where the internal resistance of the battery was the same as the resistance of its external load. Under these circumstances the battery would have an efficiency of 50 per cent and scientists thought that this should be the condition at which a dynamo could be operated to the best advantage.

Development of a High Resistance Platinum Lamp

Edison now had a dynamo that would give a constant voltage of about 110 volts between the two wire conductors leading from the armature, to which one or more lamps could be connected. By applying Ohm's law, he reasoned that the smaller the amount of electrical power a lamp for this system should take, the higher should be its resistance. For example, suppose an incandescent lamp is to be made to consume 550 watts, which was about the rating of the arc lamps then made, but that this lamp should be designed for use on 110 volts. As the watts are equal to the volts times the amperes, a 550-watt, 110-volt lamp will consume 5 amperes, and by Ohm's law, which is that the amperes equal the volts divided by the ohms, this 550-watt lamp will have a resistance of 22 ohms. Similarly a 110-watt, 110-volt lamp would have a resistance of 110 ohms.

THE INCANDESCENT LAMP

The current in the series circuits on which arc lamps were then commercially operated was about ten amperes, although some systems were later designed for twenty amperes. The lamps that Edison had made previously were designed for use on these 10-ampere circuits and consumed about 110 watts. The voltage across the terminals of the lamp was therefore 11 volts and the resistance of the lamp burner 1.1 ohms. Thus the resistance of the lamps he had previ-

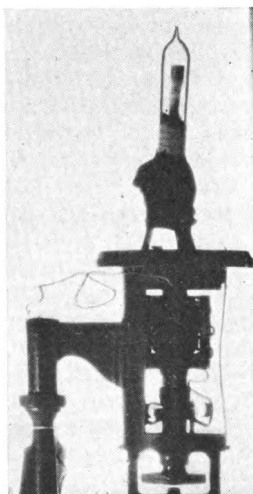

EDISON'S FIRST HIGH RESISTANCE LAMP, 1879

This had a long, thin platinum wire mounted on pipe clay and coated with zirconium oxide. It had a diaphragm thermostat which cut off the current momentarily if the burner got too hot. This lamp is in the Hammer Historical Collection of Incandescent Lamps. Photograph, courtesy of Major Hammer and the Association of Edison Illuminating Companies.

ously made had to be increased from 1.1 to 110 ohms before they would be suitable for his 110-volt multiple system.

All this reasoning may be difficult for the layman to understand. It was for most electricians in 1879, as they did not thoroughly understand Ohm's law. It was therefore no small accomplishment, although it may not seem so

THE INCANDESCENT LAMP

now to those familiar with electrical engineering, for Edison to have developed such a new and complete system of distributing electricity.

The first high resistance lamp that Edison designed had a long thin coiled platinum wire mounted on a piece of pipe clay and coated with oxide of zirconium to protect the platinum from oxidizing. In order to prevent the burner from operating at too high a temperature, it was protected by his diaphragm thermostat, but in this case the circuit was opened to cut off the current from the platinum wire. This was necessary because if the scheme used in former lamps for series circuits of short circuiting the burner were used in the lamp for the new multiple system, the low resistance of the short circuit across the constant pressure would cause such a heavy rush of current to flow that it would melt the conductors almost instantaneously. A patent for this lamp was applied for in February, 1879, and was granted in May, 1880.

Oxide of zirconium, while an insulator when cold, will decrease materially in resistance as it gets hotter. Current, instead of flowing through the long thin platinum wire, would then be shunted through the zirconium oxide coating between the turns of the coiled platinum wire, heating the latter to such high temperature that the lamp would short circuit itself. The lamp was therefore impractical.

During his experiments, Edison had found that platinum became extremely hard after it had been heated several times by the current flowing through it. This made it possible to operate it at much higher temperatures without danger of melting and so give much more light. He believed that the heat drove gases out of the minute pores of the platinum, causing it to become more dense by sintering the particles of platinum closer together. He then thought that if the platinum were operated in vacuum, more gases would escape from it so that it could perhaps be operated at even higher temperatures.

He therefore wound a long thin platinum wire on a spool of pipe clay, but this time he omitted the zirconium oxide

THE INCANDESCENT LAMP

coating. The platinum coil was mounted in a one-piece all-glass globe, all joints being fused by melting the glass together. The ends of the platinum wire passed through the glass, which was fused around the wire to make an air tight joint. The all-glass globe was considered necessary to maintain the high degree of vacuum then obtainable with the recently invented Geissler and Sprengel mercury vacuum pumps. The glass globe was then put inside a glass cover mounted on a holder within which was mounted a diaphragm thermostat which protected the platinum wire from excessive temperature. A patent for this lamp was applied for in April, 1879, which was granted in May, 1880.

This lamp was apparently successful, so a number of them were made to try out. But, since they consumed a lot of power in proportion to the light they gave, were short lived, and very expensive to make, they were not considered commercially practical. The platinum lamp had, it seemed, reached the limit of its possibilities so the problem appeared impossible of solution and, for a time, was abandoned.

Solution of the Incandescent Lamp Problem

Edison had done a lot of experimenting with different forms of carbon for his telephone receiver, which gave him a broad knowledge of the properties of carbon. Several months had passed since he had worked on the incandescent lamp and in the fall of 1879, he began thinking about it again. He knew that carbon had a high resistance compared with platinum. In order to get the requisite resistance, he realized that the carbon would have to be very slender. Thick carbon rods did not last very long when he subjected them to the high temperature of incandescence, so a slender piece should seemingly last but a very short time. He wondered, however, if it would last any longer in the high vacuum he had been able to obtain with his platinum lamp. It seemed foolish to try this but in order to leave no stone unturned he made the bold attempt.

The first problem was that of obtaining carbon of the requisite slenderness, and of determining what its length and diameter should be. After considerable calculation he

THE INCANDESCENT LAMP

estimated that the carbon should be not over a sixty-fourth of an inch in diameter, or about the size of ordinary heavy sewing thread. From that he conceived the idea of the possibility of carbonizing a piece of sewing thread by heating it in an air-tight crucible. This in itself was a bold thing to do, for it would not require the presence of much air in order to have the thread burn up. He estimated that the carbon should be about six inches long.

Carbonizing a substance consists of heating it away from the presence of air so that the heat does not oxidize the material, but merely drives off the volatile matter, leaving only the carbon residue behind. This is similar to distilling coal, which is put in closed retorts, heat being applied from the outside. The heat drives out a number of volatile gases from which the coal gas is obtained, which, when enriched with oils, becomes illuminating gas. Coal and many other substances contain hydro-carbon compounds and the heat decomposes them, leaving a carbon residue behind which is known as coke.

Edison cut several pieces of sewing thread and packed them in with a lot of powdered carbon in an earthenware crucible. The threads were packed so that they were "U" shaped in order to reduce the size of the glass globe in which they were to operate. The powdered carbon was partly for the purpose of minimizing the amount of air in the crucible and partly to absorb the oxygen in what little air there was left. The crucible was then covered with an earthenware top, the two being cemented together with fire clay to further exclude any air.

The crucible was then put in a furnace and subjected to a high temperature for several hours. It was then allowed to cool gradually, which took many hours before the inside had become cool enough to prevent the threads from burning up in unpacking. After many patient trials he finally obtained an unbroken carbonized thread, "filament" he called it, which then had to be fastened to a pair of platinum wires. This was finally done, after many failures, by delicate clamps. The platinum wires had been sealed

THE INCANDESCENT LAMP

in a piece of glass tubing and the filament was then fastened to the ends of the platinum by the clamps. This mounted filament was then inserted in a glass bulb, the glass tubing being fused to the neck of the bulb to make an air-tight joint. On the opposite end a small glass tube had been fused for the purpose of exhausting the air from the bulb.

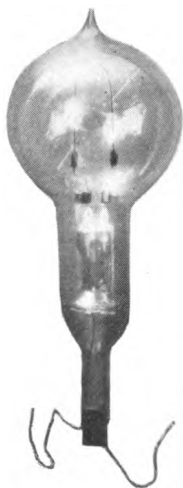

EDISON'S SUCCESSFUL HIGH RESISTANCE CARBON
LAMP

On October 21, 1879, Edison made this experimental lamp which embodies the basic features of all lamps made today. It consisted of a carbonized cotton thread operating in a very high vacuum maintained by a one piece all glass globe. This replica was made by Francis Jehl, one of Edison's pioneer assistants, by whose courtesy this photograph is reproduced. The original experimental lamp was destroyed.

The lamp was then connected to the mercury vacuum pump until the vacuum reached a high degree. Edison, however, believed from his experience with platinum that

THE INCANDESCENT LAMP

gases would also be "occluded" in the carbon filament, so in order to drive them out, he put a small amount of current through the filament to heat it slightly. Immediately the gases began to come out and it took nearly eight hours on the pump before they apparently ceased.

The crucial time had come to try the lamp out. The men in the laboratory were skeptical about it and bets were made that it would last but a few minutes. With a crowd about him, Edison turned the current on gradually by means of external resistance until the filament glowed dimly. It did not burn out. Becoming bold he gradually cut out the resistance until the lamp gave a brilliant light. Still it did not burn out. It continued to burn, and when evening came it was still going strong. This was October 21, 1879, and the lamp burned steadily for nearly two days.

Edison now felt that he was on the right track, and every thing conceivable was carbonized in the endeavor to make a better filament. After many weeks of working almost continuously day and night, he found that carbonized paper (bristol board) would give several hundred hours life. He then felt that he had a practical lamp which could be commercially used, so he decided to announce his invention and demonstrate it to the public.

The announcement was made in an article which took the entire first page of the *New York Herald* of Sunday, December 21, 1879. Several scientists proclaimed Edison's invention to be a fake. Gas stocks, however, dropped in price and stock in the Edison Electric Light Company soared to thirty-five hundred dollars a share.

The demonstration consisted of about sixty lamps mounted on poles lighting the laboratory grounds and country roads in the neighborhood. Wires were also run to several houses and lamps installed in them. Crowds came out to Menlo Park during the next few days and the Pennsylvania Railroad had to run special trains to accommodate them.

THE INCANDESCENT LAMP

Edison applied for a patent on this lamp on November 4, 1879, and on January 27, 1880, the basic lamp patent No. 223,898 was granted him. All the elements of this lamp are the same as those in the lamps made today; a high resistance filament operating in a high vacuum, maintained by a one piece all-glass globe having all joints sealed by fusion of the glass. While some lamps made today are filled with an inert gas after the lamp has been exhausted, the features are otherwise the same.



DEMONSTRATION OF EDISON'S INCANDESCENT
LIGHTING SYSTEM, 1879.

Lamps were mounted on poles lighting the neighborhood of the Laboratory at Menlo Park. The various buildings of the Laboratory can be seen in the background.

Edison's Invention

There has been some misconception of exactly what Edison did invent. He was not the first man to make an incandescent lamp, as has been indicated in the previous chapter. The principle of incandescent lighting had been established and demonstrated by several experimenters but no lamp previously made was suitable for use in large numbers over a large area like a city. His analysis of the problem brought him to the conclusion that such lamps

THE INCANDESCENT LAMP

must be connected to the circuit in multiple so each one would be independent of the others. He also realized that lamps connected in multiple must be of high resistance, for the higher their resistance the smaller were the conductors necessary to carry electricity to them. So he aimed to make a lamp of the highest practical resistance and he named this high resistance carbon burner a "filament."

He found that a carbon filament to be of high resistance must be made very thin and quite long and he also found that such filaments required a very good vacuum to preserve them. He also soon realized that glass chambers made in two separate parts, as previous lamps had been made, would not keep the very good vacuum necessary to preserve the filament. He then made the very bold step of fusing the two glass parts inseparably together and making the glass container closed at all points by fusion of the glass.

That is what Edison invented: a lamp with a high resistance filament of carbon in a vacuum contained in a glass container closed at all points by fusion of the glass and having platinum wires imbedded in the glass to carry current through the glass to the filament. And this was the first incandescent lamp which was suitable for the system of general multiple distribution which solved the problem of the "sub-division of the electric light."

Edison's patent, which the courts upheld as covering the modern incandescent lamp, covered only a particular kind of incandescent lamp which combined four elements—(1) a high resistance filament of carbon, in (2) a chamber made entirely of glass and closed at all points by fusion of the glass, which contained (3) a high vacuum and through which (4) platinum wires passed to carry current to the filament. It was a patent on a combination of old elements which produced a new thing—a lamp suitable for multiple distribution over large areas.

Commercial Installation of the Incandescent Lamp

The first commercial installation of the lamp was made on the steamship *Columbia* of the Oregon Railway and

THE INCANDESCENT LAMP

Navigation Company. This steamer was being built in Chester, Pa., and was about completed. She took a trip to New York and the Edison Electric Light Company received its first contract to equip the ship with electric light. Four dynamos were installed run from two overhead countershafts driven by a pair of vertical steam engines. Each dynamo had a capacity for sixty lamps, or about six kilowatts (eight horse power), one dynamo being used as an exciter for the other three. In this connection Edison

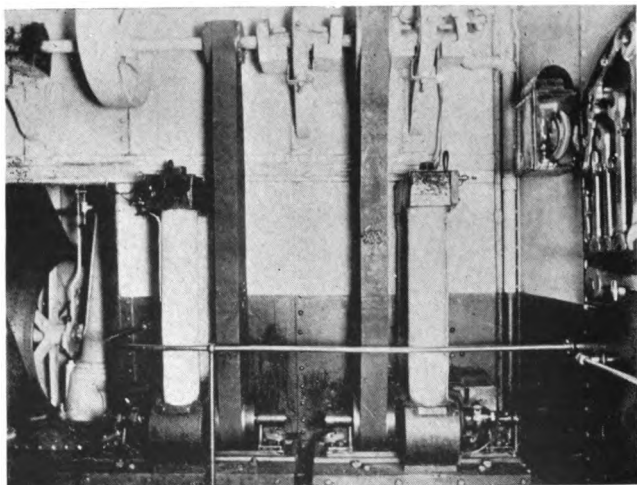

DYNAMOS ON S. S. *COLUMBIA*, 1880

This was the first commercial installation of the Edison Lamp and was started May 2, 1880. One of these dynamos is on exhibition at the United States National Museum, Washington, D. C.

had made another invention, which by the way scientists said was impossible, of connecting two or more dynamos together in multiple, each supplying its proportion of current to a single circuit. The ship was equipped with 115 lamps and the plant was started on May 2, 1880. She sailed around the Horn to San Francisco, where she arrived in July. The Advising Engineer of the Navigation Company reported

THE INCANDESCENT LAMP

that the installation was a complete success. The original installation ran for fifteen years, when the ship was overhauled and a more modern plant installed.

The next commercial installation was started about the first of the year 1881, in the shop of Hinds, Ketchum & Company, lithographers, 229 Pearl Street, New York. One dynamo was installed having a capacity for sixty lamps.

The commercial success of the incandescent lamp was quickly established. During the two years 1881-82, over

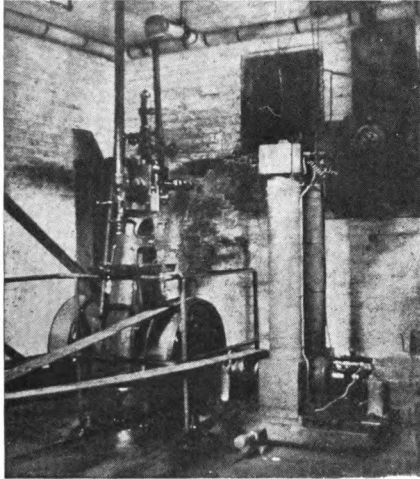

DYNAMOS, HINDS, KETCHUM & CO. 1881

This was the second installation, the first on land which was started about the first of the year, 1881. Photograph, courtesy United States National Museum.

150 other installations were put in, aggregating over 30,000 lamps. These installations included steamships, machine and car shops, mills, stores, offices, theaters, hotels, residences, etc.; all of them were entirely successful.

The First Lamp Factory

The first lamps were made in the Menlo Park Laboratory, the glass work being done in a shed there. The shed

THE INCANDESCENT LAMP

has been preserved on account of its historical interest and is now at Mazda Brook Farm (near Parsippany, New Jersey), a recreation and meeting place for the employees of the incandescent lamp department of the General Electric Company.

As so many lamps were now being made, it sorely taxed the capacity of the laboratory. In the latter part of 1880



THE FIRST INCANDESCENT LAMP FACTORY, 1880

In November, 1880, the manufacture of lamps was started in this building, located beside the Pennsylvania Railroad tracks at Menlo Park, about half a mile from the Laboratory. The four men in the foreground from left to right, are Phillip S. Dyer, Accountant; William J. Hammer, Electrician; Francis R. Upton, General Manager; and James Bradley, Master Mechanic.

a separate company was formed, called the Edison Lamp Company, to manufacture lamps, and a factory building obtained, located alongside the Pennsylvania Railroad tracks at Menlo Park about half a mile from the laboratory.

THE INCANDESCENT LAMP

During the next year, 1881, the demand for lamps had so increased that again it became imperative to get more space. A group of factory buildings were purchased at Harrison, New Jersey, the present headquarters of the Edison Lamp Works. Moving was begun in February, 1882, and manufacture in Harrison began in April of that year, the Menlo Park factory then being shut down. None of the original buildings at Harrison is now standing.

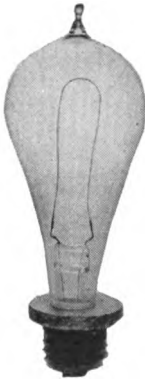

16 C.P., 110 Volts

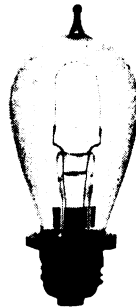

8 C.P., 55 Volts.

STANDARD EDISON LAMPS, 1881-1884.

The 16 C.P. lamp was called the "A" lamp and the 8 C.P. the "B" lamp, the latter burned two in series on 110 volts. The construction of the lamps as pictured above was standard from 1881 to 1884.

Two sizes of lamps were now being made, 16 candle-power for 110 volts and 8 candle-power for 55 volts, the latter to be burned two in series on 110 volts. The former was called the "A" lamp and the latter the "B" lamp. The A lamps were made "eight to the horse power," the term watts not being in use at that time; the lamps therefore consumed a little over 93 watts. They were rated to give 600 hours life in service, but in the latter part of 1881 the efficiency was increased, the lamps then being made ten to the horse power, rated to give 600 hours life on circuits having good voltage regulation.

THE INCANDESCENT LAMP

Development of Other Parts of Edison's System

In addition to lamps and dynamos, other parts of Edison's incandescent electric lighting system had to be invented, developed and manufactured to make the system complete.

In order to protect the dynamos from accidental overload, such as a short circuit, an automatic device had to be developed to disconnect them from the circuit.

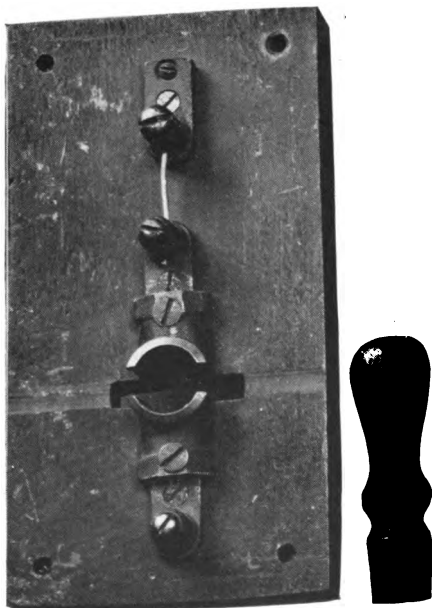

LEAD WIRE FUSE, 1880

Edison invented the fuse which is universally used. Photograph, courtesy of the New York Edison Company.

Edison invented the well-known lead wire fuse for which he obtained a patent in May, 1880. The same type of fuse was also used to protect the main circuit from troubles on individual branch circuits, so that current would be cut off only from the branch circuit where the trouble occurred.

THE INCANDESCENT LAMP

Lead made into short pieces of wire of various diameters will carry current up to an amount determined by the size of the wire. If the current is increased beyond that point, the lead wire will be heated appreciably and finally melt. If the current suddenly becomes very great, due to a short circuit, the lead wire will melt instantaneously, thereby automatically opening the circuit before any damage is done.

The demand for sockets, switches, fixtures, etc., became so great that a separate organization was formed, known as Bergmann & Company, which obtained a factory at 108



EDISON MACHINE WORKS, 1881.

This factory was located on Goerck Street, New York City, the manufacture of dynamos being shifted to it in 1881. In 1886, the Works were moved to Schenectady, N. Y.

Wooster Street, New York, and started manufacturing early in 1880. The capacity of this factory was soon outgrown and in 1882 the plant was moved to a building on the corner of Avenue B and 17th Street.

As there was insufficient space at the Menlo Park Laboratory machine shop, another separate company was organized, known as the Edison Machine Works. A factory building at Goerck Street, New York City, was obtained

THE INCANDESCENT LAMP

and the manufacture of dynamos was started there early in 1881. The capacity of this factory was soon overtaxed and in 1886, the Works were moved to Schenectady, New York.

Edison felt that the wires supplying current from a central station to the various buildings should be underground. This necessitated the design and development of a complete water tight and insulated underground method of distribution, something that had never been previously done; in fact it was considered impossible to prevent current from leaving the wires and being diverted from one

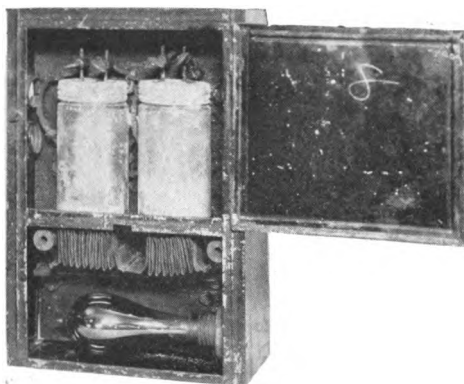

EDISON'S ELECTROLYTIC METER, 1882

This registered the amount of current used. Two chemically pure pieces of zinc were put into a glass jar containing a solution of zinc chloride. Current flowing from one zinc to the other through the solution caused particles of zinc to be transferred from one to the other. The amount of current used was measured by the loss of one and gain of the other. This meter, a double one, is in the historical collection of the Edison Pioneers by whose courtesy this photograph is reproduced.

part of the system, through the earth, to another part of the system, instead of being supplied to the lamps in the buildings. He finally developed a complete system of underground tubing, joints, junction boxes, branches, etc. These were made by a subsidiary organization, the Electric Tube Company, which obtained a factory at 65 Washington Street, New York.

THE INCANDESCENT LAMP

It was also necessary to design a meter to register the amount of current used by each customer as a basis for bills to be rendered for the service given. An electrolytic meter was finally evolved and in service was found to be extremely accurate.

This meter consisted of a glass jar containing a solution of zinc sulphate and two pieces of chemically pure zinc. Direct current flowing through this cell would cause

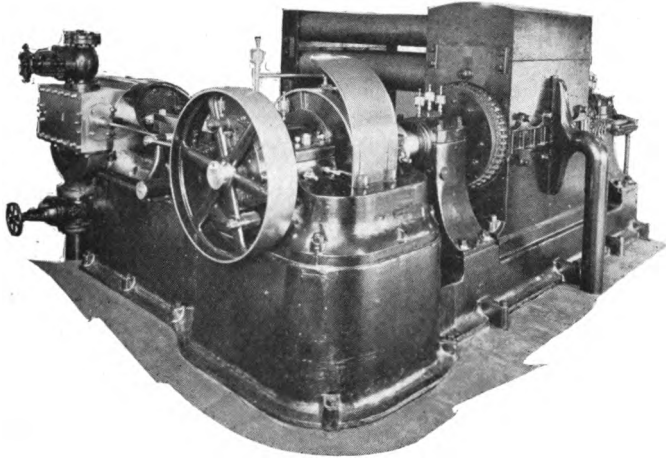

EDISON'S JUMBO DYNAMO, 1882

This dynamo had a capacity of 1200 lamps and was directly connected to a steam engine. It is one of the original machines of the Pearl Street Station of the Edison Electric Illuminating Company, now the New York Edison Company, by whose courtesy the photograph is reproduced.

particles of zinc to be transferred through the solution from one zinc terminal to the other, the amount being in proportion to the current flowing and to the length of time. Thus one piece of zinc loses and the other gains in weight. This difference measures the total quantity of current in ampere-hours used, which, if multiplied by the voltage, would give

THE INCANDESCENT LAMP

the quantity in the modern term of watt-hours. The voltage being approximately constant, the ampere-hours were a direct measure for a basis of rendering bills on the amount of electricity used. Actually only part of the total current used was shunted through the cell so that the zinc electrodes would not have to be inconveniently large in size.

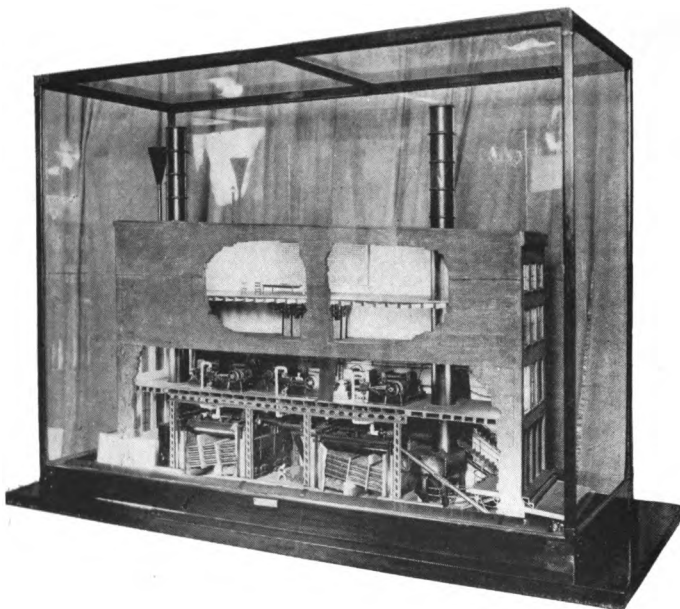

MODEL OF PEARL STREET STATION

This was the first permanent central station in the world, starting operations on September 4, 1882. Photograph by courtesy of the New York Edison Company.

In 1880, Edison decided to build a large dynamo capable of being directly connected to a steam engine instead of being belt driven. Up to this time the dynamos he had made had a capacity of sixty lamps, which in the present terminology would be rated at six kilowatts (about eight horse power).

THE INCANDESCENT LAMP

A central station of even reasonable capacity would have to have a vast number of these six kilowatt dynamos, requiring a very large space and great investment. In order to deliver 110 volts they had to be run at high speed, about a thousand revolutions per minute, far beyond that possible with a steam engine. It was, therefore, no small matter to design a large dynamo to be directly connected to a steam engine whose maximum speed at that time was about one hundred revolutions per minute.

Edison was finally able to get an engine maker to make a steam engine of about 120 horse power to run at 350 revolutions per minute and then he made a dynamo of 1200 lamp capacity to be directly connected to this machine. At this time lamps were being made ten to the horse power, each consuming about 75 watts. This 1200-light dynamo therefore had a capacity of 90 kilowatts (about 120 horse power) and was nicknamed the "Jumbo" dynamo after the well-known elephant, then the largest in captivity.

Edison had always believed that the most economical method of supplying current for incandescent lamps was by the generation of current in a large central plant instead of by individual plants. In the latter part of 1880, plans were started for a central lighting station in New York City, and the first central station, the Edison Electric Illuminating Company of New York (now the New York Edison Company) was incorporated in December, of that year.

The construction of the power plant, the more than fourteen miles of underground mains, covering an area of about one-sixth of a square mile between Spruce Street, Ferry Street and Peck Slip on the north, the East River on the east, Wall Street on the south, and Nassau Street on the west, and the wiring of consumers' premises, took nearly two years of work. Finally, on September 4, 1882, the Edison Electric Illuminating Company of New York started operations with a load of about 300 amperes supplying about 59 customers having a total of 1284 sockets. It had six Jumbo dynamos with a rated capacity of 7200 lamps, or about 540 kilowatts (720 horse power). The station was

THE INCANDESCENT LAMP

located at 257 Pearl Street, New York, and its design was quite equal to that of a modern plant. Real estate was so expensive that in order to save space the boilers were located on the ground floor and the dynamos and engines on the second floor. On the top floor was a test rack with sockets for a thousand lamps which was used to test out the station before it was put into regular operation. The great weight of the dynamos and engines on the second floor was supported by special steel beams.

The Three-wire System

Further study of the central station showed that the amount of copper required in the mains to distribute the current would have to be very great if the distance and amount of current used was large. The investment for such a great amount of copper would be very heavy, almost prohibitive. After much thought, Edison evolved the "three-wire" system of distribution which resulted in a saving of 60 per cent of the amount of copper required by his former two-wire system.

In the three-wire system, two 110-volt dynamos are connected in series to give 220 volts. The circuit consists of three wires, two connected to the outside wires of the dynamos so that the voltage between them is 220 volts. The third wire, called the neutral wire, is connected to the connection between the two dynamos and runs wherever the outside wires run. The voltage between the neutral wire and either outside wire is 110 volts, and all lamps are connected between the neutral wire and one or the other of the outside wires, the load being about evenly divided. It is good practice to make motors for 220 volts and connect them to the outside wires, as this preserves the balance between the two sides. A 110-volt motor on one side disturbs the balance a great deal.

The current flowing through the outside wires of a three-wire distributing system, provided the lamps are evenly divided, is half that which flows through the wires of a two-wire system having the same aggregate number of

THE INCANDESCENT LAMP

lamps. As the amount of power lost in these wires is equal to the square of the current flowing in them times their resistance (the C^2R loss), the resistance of the outside wires can be quadrupled for the same loss (the current being halved) by making them one-quarter the size of those used in a two-wire system. Therefore, if the load were equally balanced at all times on each side of a three-wire

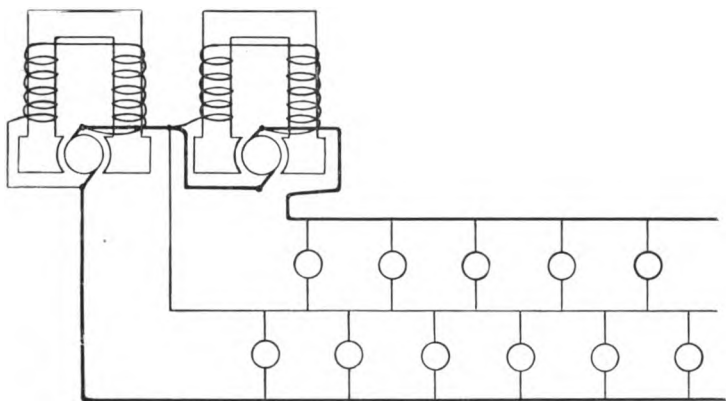

DIAGRAM OF EDISON'S THREE-WIRE SYSTEM, 1882

This system reduced the amount of copper necessary in his former two-wire distributing system by 60 per cent

system, the neutral distributing wire could be dispensed with, making a theoretical saving of 75 per cent in copper. In practice there are, however, at one time or another, more lamps burning on one side of the system than the other, so that a neutral distributing wire becomes necessary. Even so, it is possible to obtain a 60 per cent saving in copper. Edison obtained a patent on the three-wire system early in 1883.

This system is now universally used where direct current is distributed, and is largely used on alternating-current local distributing systems. Its invention has caused the

THE INCANDESCENT LAMP

saving of untold millions of dollars of investment and it is probable that without it the central station industry would have been retarded for many years; at least until the alternating-current high voltage distributing system had been established.

CHAPTER THREE

DEVELOPMENT OF FILAMENTS

In an incandescent lamp the current passing through the resistance of the filament heats it to an almost white heat and in this condition it radiates light. The hotter it is heated the more light it radiates; also the hotter it is heated the sooner it wears out. Edison decided that to be satisfactory a lamp should last 600 hours, so lamps were rated to operate at a temperature at which the filament would last 600 hours. As filaments were improved in quality the operating temperature was raised in such proportion that there would be no change in life. Each increase in filament temperature improved the efficiency of the lamp, causing it to give more light for each unit of electricity used, so from the beginning it has been the endeavor to improve the filament so that it could be safely operated at higher temperature.

The Carbon Filament

For about 26 years all incandescent lamps had carbon filaments made by carbonizing cellulose—paper, bamboo or cotton. All cellulose is composed largely of carbon combined with other elements, principally hydrogen and oxygen. When cellulose is slowly heated in a closed furnace, away from air, it is decomposed, the hydrogen and oxygen and some of the carbon is driven out and the carbon skeleton remains. This carbon skeleton is the filament. It is very dense and hard and much like anthracite coal.

Edison's first commercial lamps had a filament of carbonized paper which was rather porous and fragile. When the lamp factory was started in 1880, the lamps were made with filaments of carbonized bamboo which was very hard and strong. Much had to be learned about carbonizing

THE INCANDESCENT LAMP

bamboo, it shrinks from 20 to 30 per cent during the process, and it must be free to shrink but must not be allowed to distort. If the shrinkage is too much restrained, weaknesses in the filament will result. The atmosphere surrounding the filament during the carbonizing and cooling must be a reducing atmosphere, free from air. The temperature of the carbonization, especially when the decom-

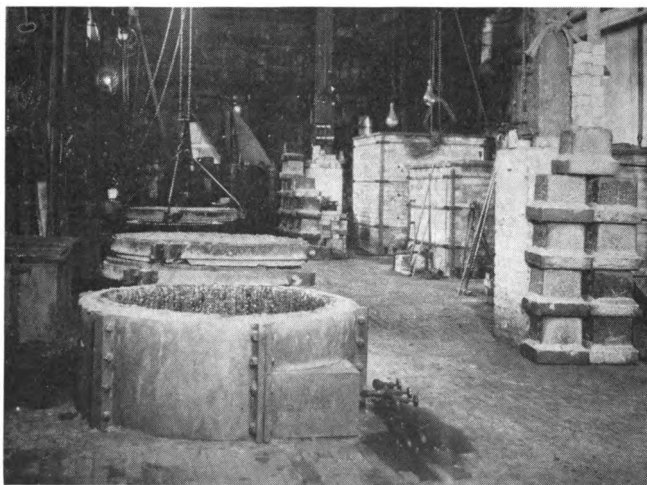

CARBONIZING FURNACES

position of the cellulose is going on, must be very slowly raised or the filaments will be stuck together because of too rapid distillation of the hydro-carbons. After reaching 600 deg. F. the temperature may be rapidly increased until the crucibles are white hot. As the crucibles containing the filaments cool down they must be surrounded by a reducing gas to prevent air reaching the filaments.

Edison sent several men all over the world to get samples of different bamboos. In the summer of 1880, William H.

THE INCANDESCENT LAMP

Moore went to China and Japan. He sent great bales of samples to Menlo Park and after careful tests, a certain variety and growth of Japanese bamboo called "Madake" was found to be the best. Moore was instructed to arrange for the cultivation and shipment of this, so he got a Japanese farmer to do it. The farmer displayed such ingenuity in fertilizing and cross fertilization that the product was constantly improved. It was used until 1894.

In December, 1880, John C. Brauner was sent to South America. He travelled over two thousand miles on foot and by canoe in the wilds of southern Brazil and secured a great variety of specimens of bamboo. None, however, was found to be superior to the Japanese bamboo then being used.

Another expedition was sent to Cuba and Jamaica, the trip taking two months. Three men explored the Florida swamps for five months. None, however, found samples as good as the Japanese variety.

A few years later (1887) two men, Frank McGowan and C. F. Hanington, went to Brazil and up the Amazon River for 2300 miles. There the two separated, McGowan exploring Peru, Ecuador and Colombia, Hanington went down the Amazon River again, up the La Plata River and through Uruguay, Argentine and Paraguay. McGowan's trip was particularly dangerous as he went through a comparatively wild and unknown country filled with hostile natives.

The last trip of this kind was made by James Ricalton who went completely around the world, the trip taking exactly one year. He was unable, however, to find a fiber better than that being obtained from Japan.

Clamps

Prior to 1881 the filament was fastened to the leading-in wires by delicate clamps. This is why the joint between the filament and leading-in wire is often called the clamp. From 1881 to 1886, this connection between the filament and the leading-in wire was copperplated. To keep the

THE INCANDESCENT LAMP

copper from being melted by the hot filament the ends of the latter were made large enough to radiate the heat and so keep the temperature down. The filaments were cut with these large ends on them; this increased the expense and trouble of making them and prevented any adjustment of length after they were cut.

Differences in dimensions due to shrinkage or cutting inaccuracies made these filaments quite different in voltage, so that in any lot of lamps made, the voltage of individual

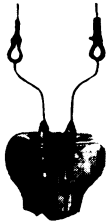

FILAMENT
CLAMPS, 1880

The filament was originally fastened to the leading-in wires by delicate clamps.



COPPERPLATED
CLAMPS, 1881

From 1881 to 1886 the connection between the filament and leading-in wires was made by copperplating them together.



CARBON PASTE
CLAMPS, 1886

A carbon paste was used to fasten the leading-in wires to the filament.

lamps would vary 15 or 20 per cent. To utilize these lamps, electric lighting plants were arranged to be operated at different voltages. Plants operating all the way from 95 to 125 volts were thus established all because it was impossible to make all the lamps of the desired voltage which was 110.

About 1886 carbon paste was adopted for making the connection between the filament and the leading-in wire. Since this paste joint would not melt or be injured by the hot filament, enlarged ends were no longer necessary on the filaments. This reduced the cost and simplified the manufacture of filaments, permitting any adjustment of their length which was desirable after carbonization. Although this somewhat reduced the variation in voltages of lamps

THE INCANDESCENT LAMP

made, the difference was still so considerable that each lamp had to be photometered to determine its voltage at its proper candle power.

The carbon paste used in these lamps was first made by mixing graphite and india ink, and later by mixing graphite with caramelized sugar and gum arabic. Paste for large size filaments was made of graphite, soft coal and coal tar pitch.

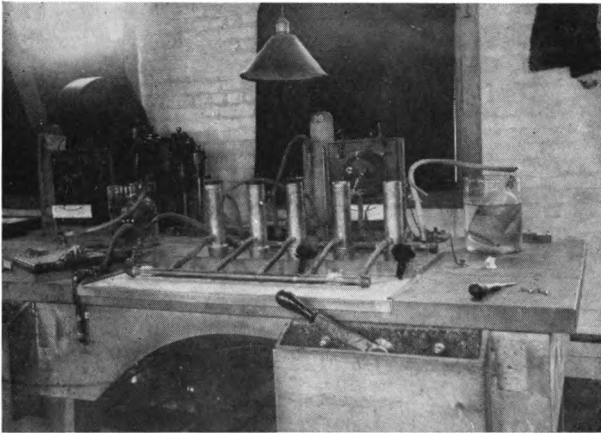

TREATING CARBON FILAMENTS, 1893

The carbon filament was materially improved by coating it with graphite. This was done by heating the filament by passing current through it for a few seconds in gasoline vapor.

The joints containing pitch were heated red hot before sealing the filament in the bulb to reduce the pasted joint to coke.

Treated Carbon Filaments

For over ten years the filaments used in all Edison lamps were carbonized bamboo. Other lamp manufacturers used an additional process called "treating" which was patented by Sawyer and Man. In this treating operation the filaments were held by clamps in a bottle which was

THE INCANDESCENT LAMP

connected on one side to a vacuum pump and on the other to a bottle containing gasoline. The vacuum pump first drew the air out of the bottle containing the filament and then drew gasoline vapor into it. Electric current was then passed through the filament, heating it to a very high temperature, the gasoline vapor in contact with the filament was decomposed and a layer of graphitic carbon was deposited on the filament. This process was capable of nice adjustment and gave the filament just the resistance desired. The graphitic coating also gave the filament a much better light radiating characteristic and considerably reduced the variation of voltages in the lamps. This patent expired in 1893 and after that Edison lamp filaments were so treated.

Later an automatic treating machine was developed by John W. Howell. In this machine the operator made no adjustments, only putting filaments in the bottle and taking them out. With this machine the gasoline was held in an underground tank outside the building, pipes bringing only the gasoline vapor indoors. Thus the danger of fire was removed, which was always present when each operator had a two-quart bottle of gasoline on the table beside her, as was previously the case.

The quality of the treated carbon filament depended upon the amount of gasoline vapor in the bottle and the temperature of the filament during treating. The amount of vapor in the bottle was measured by a "dose" bottle which was connected first to the vacuum pump, then to the gasoline vapor supply which filled it with vapor, and then to the treating bottle which had been exhausted of air and into which the dose bottle emptied its dose of vapor. The electric current was adjusted to maintain the filament at an approximately constant temperature during the treating operation, which required about $3\frac{1}{2}$ seconds. During this time the resistance of the filament was reduced to one-third of its resistance before treating.

In this treating machine there were four treating bottles which were used in regular order. Stoppers, through which

THE INCANDESCENT LAMP

extended clamps which held the filaments and connected them to the electric current, fitted the bottles. When a filament was placed in a bottle, the latter was connected to a vacuum pump which pumped the air out of it. Then the bottle was connected with the dose bottle which gave it the correct amount of gasoline vapor. Electric current was then passed through the filament, treating it to the proper resistance, at which point the current was cut off by an automatic device. Air was then admitted to the bottle, the filament

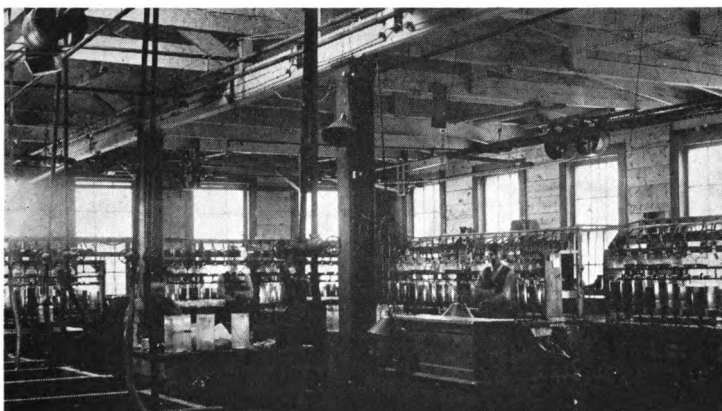

SQUIRTING THE CELLULOSE CARBON FILAMENT, 1894

Cotton was dissolved in a hot zinc chloride solution, the syrup being squirted through a die into alcohol to harden the thread formed. This thread was then washed, dried, wound on forms to give it the desired shape, cut off in bunches and carbonized.

taken out and a new filament put in its place. All this, except putting the filament in the clamps and removing it, was done automatically by means of two flat rotary valves, invented by Mr. Howell. He also invented the mechanism which operated them.

Squirting Cellulose Carbon Filament

In the Spring of 1888, Leigh S. Powell, an Englishman, developed a process he had originated for preparing cellu-

THE INCANDESCENT LAMP

lose for filaments. Sir Joseph W. Swan had some time previously invented a process along very similar lines. The two processes, although the same in principle, consisting as they did of projection of a solution containing cellulose through a nozzle into a setting liquid, were very different as regards the materials needed and the operations and apparatus employed.

In Swan's process nitro-cellulose (gun cotton) was dissolved in acetic acid. After squirting the solution through

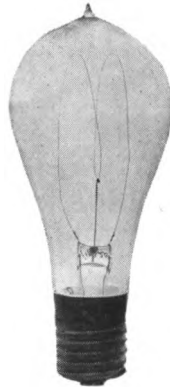

TREATED SQUIRTED CELLULOSE CARBON LAMP, 1894
The lower specific resistance of this filament required that its length be increased, the filament having a loop which was anchored to the stem.

a small orifice into alcohol and washing the thread so formed, it was necessary to denitrate the thread before it could be carbonized. In Powell's process the danger of using and denitrating the gun cotton was eliminated. Cotton was dissolved in a hot zinc chloride solution to form a syrup which was squirted through a die into alcohol. The alcohol solidified the squirted thread and dissolved out some of the zinc chloride, the rest of the zinc chloride being washed out with several changes of water. The thread was then wound on drums and

THE INCANDESCENT LAMP

dried. It was then a strong, smooth, round, structureless, cellulose thread which was wound on forms to give it the desired shape, cut off in bunches, packed in crucibles and carbonized.

With this squirted cellulose, filaments of any desired length could be made, whereas with bamboo the length was limited to the distance between the joints of the cane and was not long enough for treated filaments of the desired dimensions. The treated squirted cellulose oval anchored filaments were the best carbon filaments ever made, their commercial adoption in this country beginning about 1894.

Aggregate Improvement of the Carbon Filament

The lamps commercially sold in 1881 produced, when new, 1.68 lumens per watt. Lumens per watt is the term now used to express the efficiency of a lamp. A lumen is the amount of light in a beam having a cross-section of one square foot at a distance of one foot from a light source of one candle power. If a light source of one spherical candle power be placed at the center of a sphere of one foot radius, it will give one lumen on each square foot of surface of the sphere. As there are 12.57 square feet of surface on a sphere of one foot radius, one spherical candle power will give 12.57 lumens. Therefore, any light source will give 12.57 lumens for each spherical candle power; that is, the number of lumens given by any lamp is 12.57 times its spherical candle power. Carbon lamps were rated in horizontal candle power and the ratio of their horizontal candle power to their spherical candle power varied considerably. To determine their lumens, their spherical candle power must first be determined, which, multiplied by 12.57, gives their lumens.

The efficiency of 1.68 lumens per watt was steadily improved, first by improved methods of carbonizing and exhausting, then by surfacing the filament with asphalt, then by further improvements in vacuum production, including the Malignani chemical exhaust, and finally by the hydrocarbon treating process and the squirted cellulose filament. These improvements cannot be separately valued, but the carbon lamp of 1906, which is practically the same

THE INCANDESCENT LAMP

as the few now made, gave 3.4 lumens per watt. If the 1906 carbon lamp were burned at the same efficiency as that of the lamp of 1881, it would last 139 times as long, so it may be said that the quality of the 1906 lamp was 139 times better than that of the 1881 lamp.

The GEM or Metallized Carbon Filament

Dr. Willis R. Whitney, head of the Research Laboratory of the General Electric Company at Schenectady, had developed an electric resistance furnace. This consisted of a carbon tube, about three inches in diameter, inside of which articles to be heated could be placed. A heavy current of several thousand amperes was passed through the tube, heating it to a very high temperature, estimated to be about 3500 deg. C., which is about 500 deg. below the melting point of carbon and about 1650 deg. above the operating temperature of the carbon filament.

To give an idea of the terrifically high temperature reached by this electric furnace, the writer once looked directly into the open end of one of the tubes when it was fully heated and, when the eyes were adjusted to the task, held a 50-volt carbon filament lamp directly between the eye and the hot interior of the tube. The voltage on the lamp was then slowly raised and, when the voltage on the 50-volt filament was over 100 volts, the filament looked like a dark line on the background of the hot tube.

Dr. Whitney's original experiments were based on the idea that previous carbon filaments still retained small traces of such ash oxides as silica and alumina, substances which are not readily reduced by carbon at lamp temperature. It was evident that bulb blackening of carbon lamps might be due to the reaction of heat on carbon dioxide by which carbon monoxide and carbon are formed. The conditions of a lamp were such that this carbon could be deposited on the glass and the monoxide could react again with the filament to give more dioxide. In this way a steady blackening of glass could proceed indefinitely. The application of excessive temperatures to the filaments in vacuo could not succeed in removing the ash oxide because the carbon

THE INCANDESCENT LAMP

would itself vaporize too much, but it was evident that the filaments could not vaporize inside a highly heated carbon tube, while the oxides would be reduced by such excessive temperatures. The effect actually produced of changing the nature of the graphite coating in the treated filament was not anticipated.

The highest temperature reached during the time a carbon filament is carbonized is about 2700 deg. and is, therefore, considerably below that which Dr. Whitney was

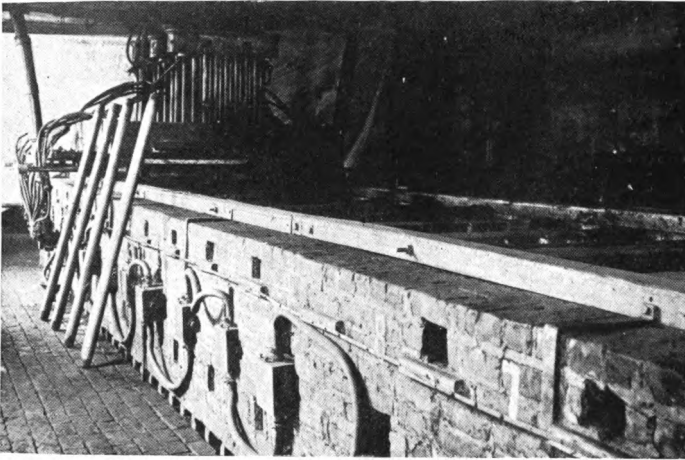

ELECTRIC RESISTANCE FURNACE, 1905

Dr. W. R. Whitney invented the GEM lamp which had a carbon filament subjected to the high temperature of an electric resistance furnace which he also invented. The GEM lamp was 25 per cent more efficient than the regular carbon lamp.

able to obtain with his furnace. Having some filaments on hand, he decided to try the experiment of heating these already carbonized filaments to see if they could be improved. After subjecting them to the high temperature, he made them into lamps in his laboratory and life tested them. They gave surprisingly good results.

He ordered some filaments from Harrison to repeat the experiment, but these failed to give good results. A second

THE INCANDESCENT LAMP

lot of filaments sent him were no better. Upon investigation it was found that he had thought that the filaments, which he had on hand and which gave good results, were untreated filaments, whereas they were really treated filaments, so that he had ordered untreated filaments from Harrison with which to repeat his experiments. He thereupon obtained some treated filaments from Harrison and this time he repeated his original success.

These treated filaments, after being subjected to the high temperature of the electric furnace, were very much blistered, as if gases had come out from within the filament. It was found that these blisters disappeared if the untreated filament were first heated in the electric furnace, then treated and then again heated in the furnace. A lamp with this filament was developed and called the GEM or metallized carbon filament lamp and was put on the market in 1905. Dr. Whitney obtained a patent on it in March, 1909, the original application for which was made in February, 1904. It was operated at 25 per cent higher efficiency than the regular carbon lamp, or 4.25 lumens per watt for the GEM compared with 3.40 for the regular carbon lamp. The same life results (600 hours) were obtained with both lamps. If the GEM lamp were operated at the same efficiency as the regular carbon lamp, it would last $4\frac{3}{4}$ times as long, hence, its quality may be said to be $4\frac{3}{4}$ times as good.

The resistance characteristic of an ordinary treated carbon filament is "negative," that is, its resistance decreases with increases in temperature. Metals have a "positive" characteristic and the resistance of the GEM filament increases with increases in temperature, similar to that of metals. This is why the new filament was called the metallized carbon or GEM (General Electric Metallized) filament.

The chief change in the physical properties of the GEM compared with the carbon filament, which made it possible to operate it safely at a higher temperature (about 1900 deg. C.) and so give a greater efficiency, was the change in the treated coating of the filament which is called the

THE INCANDESCENT LAMP

"shell." This shell is graphite, both before and after firing in the electric furnace, as has been determined by chemical test. Furthermore, it has the greasy feel of graphite and gives the characteristic pencil mark of graphite on white paper. The shell after firing is a purer graphite, as its specific gravity is much higher and it is much tougher and more flexible than before. The shell can be pulled off the core (the base filament) in short tubular sections. This fired shell, if pressed flat, will spring back to its original form when the pressure is removed, whereas the unfired shell will break with very little pressure. The unfired shell has a negative resistance characteristic up to a certain temperature, after which it has a slightly positive characteristic. The fired shell has a much lower cold resistance and a decidedly positive characteristic at all temperatures.

Firing the core drives out most of its mineral ash constituents and so prevents blistering of the finished filament. The ash content is more volatile than carbon. This ash content (as well as the carbon of the filament) vaporizes in an ordinary carbon lamp during its burning life, condensing on the bulb, and forms part of the discoloration on the bulb. Owing to the small amount of ash present in the GEM filament the lamp maintains its candle power during life much better than the regular carbon lamp, due to the lesser blackening of the bulb. The untreated carbon filament is shiny black, the treated carbon is shiny gray and the GEM filament is dull gray in color. By this means it is possible to distinguish these lamps from one another.

The first GEM lamps for 110-volt service, put on the market in 1905, had two single hairpin filaments connected in series. Later it became possible to make GEM lamps having a single oval filament for use on 110 volts, these being put on the market in 1909. Lamps were made in sizes from 30 to 250 watts but, with the introduction of the tungsten filament lamp in 1907, the higher wattage sizes soon disappeared from use. The 50-watt lamp was the most popular size and was marketed until 1918, when the manufacture of all GEM lamps ceased.

THE INCANDESCENT LAMP

GEM series lamps were made for street lighting but they also quickly disappeared, as did the 30- and 60-volt GEM lamps for train lighting service, with the advent of the tungsten filament. GEM lamps for 220-volt service were not manufactured.

The Osmium Filament

Dr. Carl Auer Von Welsbach, who had produced the Welsbach gas mantle, invented the first commercial metal filament lamp, the Osmium lamp, but it was used only in Europe and in very limited quantities.

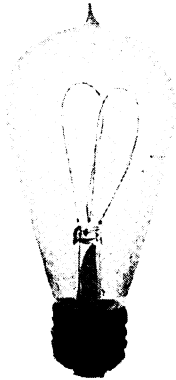

GEM LAMP, 1905
The lamp for 110-volt service originally had two hairpin filaments connected in series.

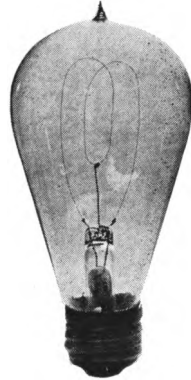

GEM LAMP, 1909
In 1909 it became possible to make a single oval filament for 110-volt service. GEM lamps disappeared from the market in 1918.

Osmium is an extremely rare and expensive metal, costing much more than platinum, which itself is over five times as expensive as gold. It is non-ductile and exceedingly brittle and so cannot be drawn into wire. Von Welsbach applied in this country in August, 1898, for patents on the lamp and processes for making the filament, the patents being granted in November, 1910. The filament

THE INCANDESCENT LAMP

was made by mixing powdered osmium with a binder, such as syrup of sugar, the resulting paste being squirted by pressure through a die. The thread formed was heated to carbonize the binder and current then passed through it in moist hydrogen gas. The current heated the thread to a high temperature which decomposed the water vapor, the oxygen of which combined with the carbon binder forming carbonic acid gas. The particles of osmium remaining were then sintered together by the high temperature, forming the filament.

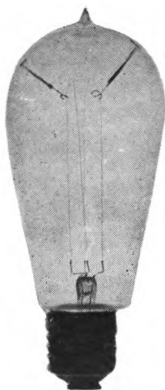

OSMIUM LAMP, 1899-1906.

A few of these lamps were made in Europe. They were considerably more efficient than the carbon lamp, but on account of the scarcity of osmium, the filament material, it was impossible to make them in large quantities.

The filament was extremely fragile and, as its resistance was very low, at first only low voltage lamps were made to burn two or more in series on 110-volt circuits. Later a few 110-volt lamps were made. Osmium melts at about 2500 deg. C., which is much below the melting point of carbon, but the filament can be operated at a higher temperature than that permissible with carbon for the same life, as it does not vaporize so easily. This made it possible to operate the lamp at 5.9 lumens per watt, which is about 75 per cent more efficient than the carbon lamp.

THE INCANDESCENT LAMP

This extremely high (at that time) efficiency lamp was a tremendous improvement, and even with its fragility, would have formed a great step forward in the lamp art if it could have been produced in large quantities. The world was ransacked for osmium. Expeditions were sent out to explore wild territory, engineers being hired to go out with pack mules to traverse unknown country far away from places man had ever visited. Even as late as the summer of 1903, the Canadian Northwest was being explored, but with all these efforts and expenditures, the best that could be done was to obtain but a small quantity of the rare metal.

A few thousand lamps were made, and these were generally not sold, but rented so that the burned out lamps could be obtained to recover the osmium left in them. They were put on the market about 1899, and only used in a few installations in Berlin and Vienna, where the lamps were made. Manufacture of the lamp was abandoned in 1906, when the tungsten lamp appeared. Osmium lamps were not marketed in this country.

The Tantalum Filament

The metallic substance, known as tantalum, one of the elements, was discovered over a hundred years ago, about 1802. It is practically unaffected by various chemicals, an early writer stating that "even when in the midst of an acid it is unable to take the liquid unto itself." It was named after the fabled Tantalus, who was condemned to stand up to his chin in water which constantly eluded his lips when he attempted to quench his tormenting thirst.

Dr. Werner Von Bolton, a Russian chemist, in the employ of the Siemens & Halske Company, a large electrical manufacturer in Germany, discovered, about 1902, that this metallic substance really contained a considerable amount of oxide of tantalum. He removed the oxide in the metal by placing some of it between the poles of an electric arc in vacuum, a vacuum pump removing the oxygen as fast as it was released. He later found that at first he did not obtain pure tantalum because what he got was an extremely hard metal, so hard that it was impossible

THE INCANDESCENT LAMP

for a diamond drill rotating 5000 times a minute for three days to drill a hole through a sheet of it only one millimeter thick. This extreme hardness was due to impurities which disappeared when he employed electrodes of the first lot of tantalum he made. The pure metal, however, is still hard, about equal to that of the hardest steel, but it is ductile so that it can be drawn out into a fine wire, having a tensile strength of about 100,000 lb. per sq. in.

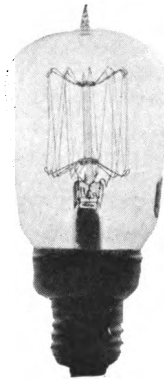

TANTALUM LAMP, 1906

This lamp had a filament of the metal tantalum, and was much more efficient than the carbon lamp. It disappeared from use in 1913.

Tantalum is about twice as heavy as iron, having a specific gravity of 14.5, that is, it is $14\frac{1}{2}$ times as heavy as distilled water at ordinary temperature. Its melting temperature is high, about 2850 deg. C., but while this is considerably below that of carbon, Dr. Von Bolton found that it could be operated as a lamp filament at somewhat higher temperature than that permissible with the GEM lamp for the same life because it vaporized less easily. This made it possible for him to produce a tantalum lamp to operate at 4.8 lumens per watt. It had a quality value

THE INCANDESCENT LAMP

nearly $2\frac{3}{4}$ times that of the GEM lamp and if the two were operated at the same efficiency, the tantalum lamp would live 2.71 times as long as the GEM lamp. Dr. Von Bolton applied for a U. S. patent in May, 1902, which was granted in April, 1906.

Tantalum has a relatively low electrical resistance, so the filament for a 110-volt lamp had to be long and thin. The 44-watt lamp originally made had a wire filament 1.8 thousandths of an inch in diameter and about twenty inches long. For comparison the 50-watt carbon lamp filament is four thousandths of an inch in diameter and about nine inches long. A human hair is about three thousandths of an inch in diameter.

The tantalum lamp was put on the market in this country in 1906. The original 44-watt lamp was later changed to 40 watts, and an 80-watt lamp added for 110-volt circuits. It was also supplied in round bulbs, and lamps for 30-, 60- and 220-volt service were also made. It was found that while good life results were obtained on direct-current circuits, the filament, when burned on alternating current, rapidly crystallized and so did not last long. As direct current is supplied by lighting companies in only a few cities, the use of the lamp was limited, the greater portion of electric current supplied being alternating. The lamp disappeared from the market in 1913.

The Tungsten Filament

The metal tungsten, an element, was discovered in 1781, and for more than a century and a quarter was known to chemists as an entirely intractable metal, existing only as a powder of hard, brittle particles or as a rough, more or less fused mass, incapable of being forged or worked in any way. It was used only in alloys, notably in tungsten steel, making the steel extremely hard, and as a constituent of chemical compounds.

It is extremely heavy, nearly twice as heavy as lead. It is now known to have a specific gravity of 19.1; prior to its use as a filament, authorities stated it to be from about

THE INCANDESCENT LAMP

17.2 to 17.6. It has a melting temperature of about 3400 deg. C., a temperature at which asbestos and fire brick would melt like wax in a furnace. But little of the properties of the metal itself were known until it was used in a lamp, one authority even stating as late as 1903, that its melting temperature was 1500 deg. The operating temperature of a treated carbon filament is about 350 deg. higher than this.

The name tungsten is derived from the Swedish "Tung" meaning heavy and "Sten" meaning stone. Its chemical symbol "W" is derived from Wolff, one of the early experimenters on the metal.

Tungsten is plentiful, being obtained from various ores, such as Wolframite, a tungstate of iron and manganese, and Sheelite, a tungstate of calcium. Ores are mined in Colorado, California, New Mexico, China, Korea, and many other places. The ore is usually purified to the oxide, which is a yellow powder resembling sulphur. There are lower oxides which are bluish and brown. The oxides are further reduced to tungsten, which appears as a fine gray-black powder.

Early Suggested Uses of Tungsten in Incandescent Lamps

As a matter of record it is interesting to note that Turner D. Bottome, an American, applied for a patent in September, 1887 (granted in April, 1889), which discloses a process consisting of saturating carbon filaments with a solution containing a tungsten compound, baking the filaments and reducing the tungsten compound to tungsten metal. This process was to be repeated as often as necessary in order to obtain the proper amount of tungsten in the carbon filament. Bottome's idea was that by adding tungsten to the carbon it would produce an additional hardness to the filament such as is conferred upon steel by the addition of tungsten. The scheme was never used. Such a filament, if operated above the normal temperature of the carbon lamp, would rapidly blacken the bulb with a deposit of carbon.

THE INCANDESCENT LAMP

Alexandre De Lodyguine, a Russian, suggested the use of tungsten and other materials to make up a composite filament in patents he applied for in 1893 and 1894. At this time Edison's basic carbon lamp patent had been sustained in the courts, and the Westinghouse Company was trying to develop a lamp that would not infringe this patent. De Lodyguine was retained by the Westinghouse Company to do this, and put in two years of intensive work but without success.

De Lodyguine's idea was to build up a high resistance coating or shell on a platinum or carbon core, thereby making a high resistance composite filament. The shell could consist of molybdenum, tungsten, rhodium, iridium, ruthenium, osmium or chromium. The scheme was never used, as with a platinum core, the platinum would melt, soak through the shell and vaporize quickly, blackening the bulb if it were operated above the filament temperature of a carbon lamp. Platinum melts about a hundred degrees below the operating temperature of the carbon lamp. With a carbon core the same difficulty would occur as in Bot-tome's scheme.

Invention of the Tungsten Filament Lamp

Alexander Just and Franz Hanaman, in 1902, were laboratory assistants to the professor of chemistry in the Technical High School in Vienna. Just was making use of his spare time by working in another laboratory trying to develop an incandescent lamp having a filament of boron. His means were very limited, his whole income being about \$55 per month. In August, 1902, he got his co-worker Hanaman, whose monthly income was even less, to assist him. The two conceived the idea of trying to produce a tungsten filament lamp and they worked on both the boron and tungsten lamps for about two years. The boron lamp was a failure.

They first started experiments on the tungsten lamp by exposing a carbon filament at high temperature to the vapor of tungsten oxychloride in the presence of a small

THE INCANDESCENT LAMP

quantity of hydrogen. Their theory was that a complex chemical reaction takes place, depositing the tungsten of the oxychloride in place of the carbon, and that this reaction continues until the carbon of the filament has been entirely replaced by tungsten.

Their aim was to make a pure tungsten filament and, as they knew that tungsten was brittle and unworkable so that it could not be drawn out into a wire, they thought this carbon replacement method would finally produce a tungsten filament. This effort was a failure for the reason that the first thin coating of tungsten on the carbon filament prevents further action between the carbon and tungsten oxychloride vapor. This filament merely became one having a carbon core and a tungsten shell, and when operated at a temperature above that of the ordinary carbon lamp, the carbon would dissolve through the tungsten, vaporize, and quickly blacken the bulb, as in Bottome's scheme.

They were using a paste containing graphite and a binding material, such as coal tar, to fasten the filament to the leading-in wires. They found that much of the black deposit in the bulb came from this paste, so they heated the pasted joints in hydrogen gas and found that the blackening was very materially reduced. This led them to believe that there must be some de-carbonizing process going on. Being chemists they came to the conclusion that some oxidizing substance was acting as a go-between between the carbon and hydrogen. The hydrogen gas they obtained was produced by the action of hydrochloric acid and zinc, and they found that it contained a considerable amount of water vapor. They therefore reasoned that the high temperature decomposed the water vapor, the oxygen combining with the carbon.

Finally they evolved a process of making a substantially pure tungsten filament by coating a fine carbon filament with tungsten deposited by heating the carbon filament in a vapor of tungsten oxychloride as previously described. The coated filament was then heated to a

THE INCANDESCENT LAMP

high temperature by passing current through it in an atmosphere of neutral gases which would not react on it chemically. This heating made the carbon core dissolve into the tungsten shell surrounding it, the carbon then being removed by another heating in an atmosphere of water vapor and hydrogen. Later the first heating was dispensed with, the second heating accomplishing the results obtained by the original first heating.

Another process was evolved by them, which was commercially used in this country for several years. It produced what was called the "pressed" filament and consisted of mixing tungsten powder with an organic binding material, of which there are several that can be used. In the commercial process, a very fine grained tungsten powder was mixed with a solution of sugar and gum arabic to make a thick paste. This paste was squirted under high pressure through a diamond die and caught in loops on a piece of cardboard. Tungsten is so hard that it will soon wear out any other than a diamond die. The loops were baked enough to partly carbonize the binder and then were passed through a "forming" machine in which electric current of increasing amount was passed through them while they were in an atmosphere of hydrogen and nitrogen which contained some moisture. This removed the binder and left substantially pure tungsten in the filaments.

Just and Hanaman found that the substantially pure tungsten filament they were able to make could be operated at about $7\frac{3}{4}$ lumens per watt and yet give good life results. This was an enormous improvement over all previous lamps made. Their financial resources by this time were so depleted that they did not have sufficient money to apply for patents to protect their invention in all the various European countries. They finally were able to borrow \$60 from a chemical manufacturer in Vienna with which to apply for British and French patents, which were filed on Nov. 4, 1904.

THE INCANDESCENT LAMP

They found it difficult to obtain financial assistance to develop their invention further, but they finally induced a carbon lamp manufacturer in Ujpest, Hungary, to try out their lamp. Much further experimental work had to be done before the lamp could be produced commercially, the lamps being put on the market in Europe in limited quantities in September, 1906. They used the carbon filament displacement method at first, later the pressed filament. In July, 1905, they applied for a patent in this country.

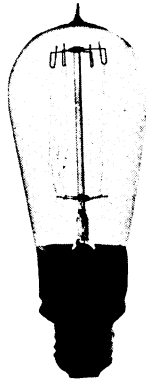

MULTIPLE TUNGSTEN FILAMENT LAMP, 1907

This lamp was originally nearly three times as efficient as the carbon lamp.

The General Electric Company bought Just and Hanaman's American patent rights and after much development work, marketed, early in 1907, a street series and 100-volt multiple lamp. The filament was rather fragile and the lamps had to be handled carefully. Notwithstanding the fragility, their high efficiency made them a great commercial success, the tungsten filament making the greatest advance ever made in the quality value of the vacuum incandescent lamp. If the 100-watt,

THE INCANDESCENT LAMP

110-volt tungsten lamp of 1907, having an efficiency of 7.85 lumens per watt, were operated at the same efficiency as that of the tantalum lamp, it would last 27.1 times as long, making its advance over the tantalum lamp just ten times the advance of the tantalum over the GEM lamp. Nearly half a million tungsten filament lamps were sold during the first year, 1907.

Tungsten has a low electrical resistance, lower than tantalum, about half that of platinum and very much lower than that of carbon. However, when heated, tungsten increases greatly in resistance and even though the carbon filament decreases in resistance when heated, the tungsten filament in a lamp must be much longer and thinner than that in a carbon lamp. The 40-watt, 110-volt vacuum tungsten filament lamp has a filament very nearly two feet long and about 1.6 thousandths of an inch in diameter. In order to get this long tungsten filament in a bulb, several hairpin loops of the pressed tungsten filaments were mounted on a spider, and connected in series with each other to get the requisite resistance for 110-volt circuits.

Series lamps were also put on the market which quickly displaced the carbon and GEM lamps used in street lighting. They not only consumed less energy for the same candle power given by the other lamps, but made it possible to greatly increase the lamp capacity of the constant current transformers used. As a result, larger sizes and greater numbers of street lights began to be used.

The low resistance of tungsten made lower voltage lamps commercially feasible, so that in lighting trains 30- and 60-volt tungsten lamps immediately displaced the lamps formerly used. The lighting of automobiles with 6-volt lamps operating on storage batteries soon replaced the oil and acetylene lamps formerly used. Flashlights received a tremendous boom, as the $2\frac{1}{2}$ - and $3\frac{1}{2}$ -volt tungsten filament lamps tripled the capacity of the small dry batteries used.

THE INCANDESCENT LAMP

Tungsten Lamp Patent Granted to Just and Hanaman

There were two other inventors, who had applied before Just and Hanaman, to the Patent Office in Washington for patents covering a tungsten lamp filament. One was Von Bolton, the inventor of the tantalum lamp, whose application was dated November 10, 1904, and the other was Dr. Hanz Kuzel, a German, who applied January 4, 1905. Just and Hanaman filed their application on July 6, 1905.

Von Bolton's application covered various metals, among which tungsten was mentioned, which were to be melted and could be fashioned into filaments by a drawing process. He had discovered that the supposedly non-ductile metal tantalum, if purified, became ductile and could be drawn into a wire and would make a good lamp filament. He did not know that any other metal would make a good lamp filament, but there was a large group of metals whose properties were little known and whose adaptability to the lamp art was not even known at all. He appears to have thought that possibly some of these other metals might be made ductile if purified and thus make good lamp filaments and to have wondered if his success with tantalum might not be repeated with some other metal by some other inventor. Desirous of forestalling such other inventor, Von Bolton filed his speculative patent application.

Up to this time it had been impossible to produce ductile tungsten so that it could be drawn into a wire by any known process. The Patent Office, therefore, questioned the operativeness of Von Bolton's application. As will be shown, a brilliant invention was later made by another inventor by which tungsten could be drawn into a wire by an entirely new process. This new process was not covered by Von Bolton's application.

The Siemens & Halske Company, Von Bolton's employer, had in 1903 abandoned his theory of the ability to draw tungsten. They had, in that year, obtained an

THE INCANDESCENT LAMP

English patent covering a process of making a tungsten filament by means of an alloy of tungsten and nickel, drawing this alloy into wire and then removing the nickel. In this patent it stated the impossibility of directly making a tungsten filament and spoke of tungsten as a non-ductile refractory metal.

Dr. Kuzel's application covered a process of making a filament from any one of fourteen metals, among which tungsten was included. The process consisted of reducing these metals to a colloidal condition which, when made into a paste with water (no organic binder being used), was squirted through a die to form a thread. The tungsten particles of the thread were then sintered together to form the filament.

It then appeared to be only a question of a proven priority date of invention as to which of the two parties, Just and Hanaman or Kuzel, would be granted the patent. Evidence was introduced to the U.S. Patent Office that Just and Hanaman had filed applications for their French and British Patents on November 4, 1904. This was prior to the U.S. application of both Kuzel (January, 4, 1906) and Von Bolton (November 10, 1904). In July, 1911, the Assistant Commissioner of Patents handed down a very thorough and extended decision on the patent interference, and the patent was granted to Just and Hanaman in February, 1912.

The Trade Mark Mazda

The trade mark MAZDA was adopted by the General Electric Company late in 1909, but is now used by more than one manufacturer. It is not the name of a thing but the mark of a research service rendered to the manufacturer by the Research Laboratories of the General Electric Company at Schenectady, New York. It comprises not only the incandescent lamp research work done by these laboratories and the data obtained from the testing and inspection work done throughout the company, costing over a million dollars a year, but also the

THE INCANDESCENT LAMP

accumulation of scientific and practical data from laboratories, factories, etc., all over the world. The results are transmitted to the manufacturers entitled to this service, with such aid and information as will assist them to improve the quality of their lamps.

A MAZDA lamp is, therefore, the product of the latest and best method of incandescent lamp making. The filaments of all MAZDA lamps are at present made of tungsten, but when any material more suitable for the purpose is discovered or developed, it will be used.

Persian mythology gives to their ancient god of light the name Ahura Mazda, and to the Persians, light was knowledge. MAZDA service therefore, very fittingly stands for the accumulation and transmission to lamp manufacturers of the knowledge which will enable them to produce the best light.

The Drawn Tungsten Wire Filament

As has been stated, tungsten was known to be a very hard, non-ductile and brittle metal which could not be drawn into a wire. Many scientists were misled into the belief that if it were purified it would become ductile as Von Bolton found to be the case with tantalum. Prior to 1906, it was the universal opinion that tungsten could not be made ductile. It was known that when heated to very high temperatures it could be bent, but when cool it was always brittle.

Dr. William D. Coolidge, of the Research Laboratories of the General Electric Company at Schenectady, began an investigation of the subject in 1906. He first produced tungsten as pure as he could get it, and then deliberately added various impurities to study their effect. These experiments led him to believe that in the case of tungsten it was not the presence of impurities which made the metal brittle, but that the brittleness was an inherent characteristic of the metal itself. His first discovery, which later gave him the clue which he afterwards so brilliantly followed,

THE INCANDESCENT LAMP

consisted in finding that tungsten, carefully prepared in a particular way, could be hammered at certain temperatures and that by so hammering, the material could be considerably elongated and its form changed. While the metal which was thus hammered was brittle when allowed to cool, nevertheless Dr. Coolidge had done something which no one else had ever done and it encouraged him to continue.

At this point, he discovered a new process for getting tungsten into a dense coherent form. This process consisted in incorporating tungsten powder with a ductile metal alloy of cadmium, bismuth and mercury, squirting the mixture through a suitable die and then, by heat treatment, removing the foreign ingredients and sintering the tungsten powder. This, so-called, amalgam process was subsequently used in preparing thick tungsten filaments from which the first tungsten wire was drawn. As the amalgam process gave better squirted filaments, in the large sizes, than were at the time obtainable in any other way, it was intensively developed by Dr. Coolidge in the laboratories and later became the standard factory process for the production of high wattage and series lamp filaments.

Early in 1907, Dr. Coolidge again took up the hot working of tungsten, experimenting with a small rolling mill such as is used by jewelers. He heated the rolls, a most unusual operation, to a temperature of about 300 degrees Centigrade and passed amalgam process tungsten filaments between the hot rolls, obtaining an appreciable lengthening of the filaments. Before this time he had discovered that he could bend amalgam process filaments into special shapes by the application of proper but relatively low temperatures, going so far as to coil the filament into a spiral whose internal diameter was no greater than that of a knitting needle. This in itself was a valuable achievement, as such concentrated filaments are of value in focusing types of lamps such as those used in automobile headlights.

His next work, done late in 1907 and early in 1908, consisted in squeezing thick tungsten filaments between hot

THE INCANDESCENT LAMP

blocks of tungsten steel whose working faces had been ground parallel and hardened. An appreciable extension of the filament was obtained and when such a hot-worked filament was broken in two and one part was heated above the equiaxing temperature, measurements showed that the part which had been hot-worked and not equiaxed was stronger than the other part in the sense that it would stand cold bending through an arc of smaller radius.

Dr. Coolidge had, then, learned that suitably prepared amalgam process filaments could be bent, rolled and pressed at temperatures at which hardened alloy steel tools would not lose their temper. The hot-pressing experiments had also shown an improvement in mechanical strength resulting from such hot working.

He next decided to try hot-drawing some filaments and, guided by his earlier hot-working experience, he recognized the need of heating the die, that portion of the filament which was in tension, and the jaws of the pliers holding the end of the filament. The openings in the dies naturally were smaller than the filament, but the difference, called "the draft," had to be very small, a fraction of a thousandth of an inch, as otherwise the filament invariably broke.

In order to introduce the filament into the opening in the die, the entering end was pointed by a process which he had previously invented which consisted in electrolyzing it in a concentrated aqueous solution of potassium cyanid. This method, unlike the ordinary electrolysis of tungsten, reduced the diameter without rendering the surface pitted and porous, and hence without needless weakening of the filament at the point where it was to be grasped by the hot pliers. The die was heated by a special gas burner; that portion of the filament between the die and the pliers, pulling the filament through, was heated by a hot body of metal underneath; the pliers were heated by gas; and that portion of the filament back of the die on the entering side was, in some cases, heated by a gas heated metal under and partially surrounding the filament.

THE INCANDESCENT LAMP

In this way, in the fall of 1908, pieces of pressed tungsten filament were successfully drawn through many dies, each but little smaller than the previous one, and then it was found that a wonderful thing had been accomplished, the tungsten had lost its brittleness. The tungsten had actually become bendable, and even ductile, when cold.

The Drawing of Ordinary Ductile Metals

Ordinary ductile metals, such as wrought iron, copper, silver, gold, etc., may exist in either one of two states which are known as the "crystalline" state and the "strain-hardened" state. The crystalline state is the natural condition of the metal and is that in which it exists after it has cooled from a molten state. Under the microscope, and sometimes by the naked eye, the metal will be seen to be composed of an aggregate of crystals. Ordinary workable metals are ductile in this crystalline state. In the strain-hardened state, these crystals have been changed into fibers, threads or plates, or in some other way have been strained and distorted out of their original crystalline form.

The change from the crystalline to the strain-hardened state is produced by mechanical working at low temperatures such as by drawing the metal into wire, which is ordinarily done at room temperature. As the crystals are deformed by working, the metals become hard and springy and their workability decreases. If the strain-hardened (sometimes called "hard-drawn") fibrous metal be heated to a certain temperature, different for each metal but always below its melting temperature, and maintained long enough at this temperature, the fibers break up and recrystallize. This temperature is called the metal's "annealing" temperature and with ordinary metals it restores its ductility. Thus in drawing ordinary metals they become hard and difficult of further working. They are then annealed, bringing them back to their original ductile condition.

Ductility or its absence is a specific property of a metal, not entirely dependent upon hardness or softness, strength

THE INCANDESCENT LAMP

or weakness, nor on any other single property. For example, at room temperature, manganese steel is very hard, very strong, and very ductile; certain heat treated steels are hard, very strong, and non-ductile; copper is very soft, weak, and very ductile; lead is very soft, very weak, and only slightly ductile; and antimony is soft, weak, and non-ductile.

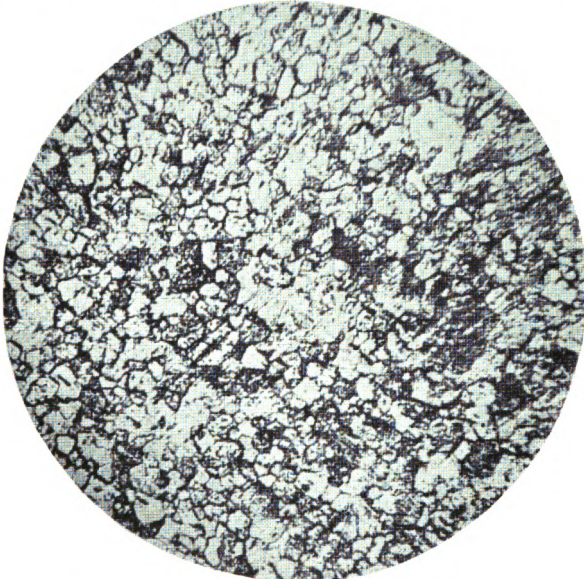

BRITTLE TUNGSTEN, CRYSTALLINE STATE

This photo micrograph shows the normally crystalline state of tungsten in which condition it is brittle.

Tungsten Ductile in Fibrous State

Under the microscope the structure of Dr. Coolidge's ductilized tungsten filament was fibrous, while that of the original brittle filament was crystalline. This is just the opposite of what had been found in the ordinary ductile

THE INCANDESCENT LAMP

metals. He had "ductilized" a non-ductile metal and, as he later discovered, had increased its strength enormously. Samples of drawn tungsten wire of one-thousandth of an inch in diameter show a tensile strength of 600,000 to 650,000 pounds per square inch. The tensile strength of this drawn tungsten is more than thirty times that of the original sintered



DUCTILE TUNGSTEN, FIBROUS STATE

When tungsten is carefully prepared in a certain manner and worked at certain temperatures, the crystals are deformed into fibers and the metal becomes ductile.

tungsten, no other material showing any such increase in strength as this. A striking feature is that no such process as that developed by Dr. Coolidge has ever been able to increase the ductility of any other metal, and no mechanical process whatever had previously produced ductility in any metal which was non-ductile.

THE INCANDESCENT LAMP

Dr. Coolidge also later found out that the ductile tungsten he had produced would, if heated to a certain high temperature, again become brittle. This might be called its annealing temperature, although an annealing temperature produces ductility in ordinary metals.

Development of the Commercial Drawn Tungsten Wire Process

While Dr. Coolidge had finally been able to make a small piece of tungsten ductile, it required much more investigation and experiment to repeat the accomplishment on a large enough scale to make the process commercially practical. In fact, as will be shown, many obstacles appeared which for some time seemed insurmountable, and it required about two years of painstaking effort and skill before the desired result was obtained. The difficulties and discouragements he met with were at times almost heart breaking.

The first piece of ductile tungsten he had produced was made from an "ingot" (if so ponderous a name can be used) consisting of a pressed tungsten filament 25 one-thousandths of an inch in diameter. In order to obtain an ingot, or slug, of a reasonable size, he first tried to press dry tungsten powder together without a binder. He used a steel mould filled with tungsten powder and tried to form the slug by pressure applied at the end. This was the natural thing to do, but instead of producing a homogeneous slug, he obtained one with a plate-like structure.

He next tried using a mould in which the pressure was applied at the side, but the resulting slug contained what he called "corner cracks." These cracks caused much difficulty and it was only after an extended study of the effect of the amount of pressure used, the method of applying the pressure, the design of the mould and many experiments on various lubricating substances which could be used on the surfaces of the mould, that he was able to make slugs free from mechanical faults.

THE INCANDESCENT LAMP

The slugs finally produced were so fragile that they could only be handled by sliding them carefully along a smooth surface. The next step was to give them some mechanical strength, which was accomplished by baking them in a tube in a stream of hydrogen.

This baking was only a preliminary stage; it was necessary to heat the slugs to a very high temperature to cause the tungsten powder to sinter together. This was done by passing a heavy current through them, like the sintering operation in making pressed filaments, but here new problems arose requiring the development of a special bottle.

In this heating operation the slug was mounted vertically and at first a rigid clamp was attached to each end, the current passing in at one clamp and out at the other. The slug was surrounded by a metal treating bottle and a stream of hydrogen gas passed through the bottle to protect the tungsten from oxidizing. When the slug was heated it shrank and usually broke in two or pulled out at one end from one of the clamps. The bottle was full of hydrogen and a certain amount of air was drawn in by the first cooling resulting from the shutting off of the current. Hydrogen and air form an explosive mixture and the result was usually a violent explosion, the very hot tungsten slug igniting the mixture, and the bottle being blown to the ceiling.

To overcome the difficulty the expedient was tried of giving the slug a slight partial treatment, reclamping it, giving it a further slight treatment, and so on, but dangerous explosions still occasionally occurred. The problem was finally solved by suspending the slug by the upper clamp, the lower clamp dipping in mercury which was kept cool by water flowing through a copper tube. The mercury would conduct current to the lower clamp and allow the slug to shrink, the apparatus being so designed that the shrinkage did not cause the lower clamp to leave the mercury.

Serious difficulty arose from another cause. The slug would occasionally break near the upper end or pull out

THE INCANDESCENT LAMP

of the upper clamp. The upper end of the slug in falling would often strike the inner surface of the bottle, forming a severe arc, and often melting a hole through the inner layer of the bottle, which was a double walled affair, cooled by water flowing between the walls. Such conditions were finally overcome by using springs instead of bolts in the clamps.

Another serious difficulty remained, however. There was a good deal of oxidization of the slug while in the bottle, the cause of which was not clear for a long time. It was finally found that it was due to the fact that when the slug was at a high temperature, the convection currents in the hydrogen gas around it were so vigorous that they extended down to the mouth of the bottle and caused air to be drawn in. To obviate this, the mouth of the bottle was allowed to dip into mercury filling a circular depression in a metal plate, which made an effective seal.

All this required several months of work, and it turned out that all the slugs produced were entirely brittle, not only when cold but also when hot, and so could not be worked. This was so discouraging that it then seemed impossible to start with a slug of anything but minute size.

He then tried, with the help of an expert, skilled in electric furnace practice, to produce a slug of tungsten by heating the metal in the high temperature of an electric-arc furnace. But this did not help, for when he attempted to work the slug it cracked all to pieces.

Feeling that he was making so little headway on the direct attack, Dr. Coolidge decided to drop work on tungsten for a time and to try hot working large masses of molybdenum. The latter metal has some of the properties of tungsten, but possesses some slight inherent ductility; so he hoped that the presumably simpler problem of working molybdenum might teach him something which would help him to work tungsten. All this effort on the hot working of the larger metal masses so far had taken over a year of his time.

THE INCANDESCENT LAMP

He then returned to his sintered tungsten slugs and tried hammering them hot by hand on an anvil, but could make no progress. Fearing that the failure was caused by his own lack of skill, he called in two expert blacksmiths. He found that it was possible to hammer the slug a little, certain blows being successful, but with others the slug would break to pieces.

He then tried his jeweler's rolling mill again, using exceedingly small drafts, but even then the slugs cracked badly. He found, however, that the work was being cooled at the point where it should remain hot, so he built a special rolling mill in which a current of about a thousand amperes passed from one roll across the tungsten to the other roll. This heated the slug at the point where it was being worked, and with it he made a little headway, but was not able to work a tungsten rod down to such a size that it could be drawn through a die.

He then went to see a manufacturer of swaging machines. These machines have two small hammers which operate at high speed as the machine is rotated, striking blows on anything placed between them. The hammers have a recess in them leaving an opening through which the rod to be swaged is fed. The minimum size of this recess determines the diameter of the rod after it has passed through the machine, the hammers being usually called swaging dies. This manufacturer had built a few machines for hot hammering steel, but on account of difficulties, the work was confined to short lengths of large cross section and the machines were not adapted to hot hammering long lengths of small cross section.

He next visited another concern where swaging machines were being used for the cold swaging of needles, but no one seemed to think that the machines were suitable for hot working rods of small diameter. Nevertheless, he obtained one of these machines, but when he tried it, even with molybdenum, the metal went all to pieces in the first two or three dies. Another difficulty was that as the dies rotated about the work, they tended to take

THE INCANDESCENT LAMP

the work with them and twist it off. He tried increasing the speed of the machine, but this only intensified the trouble and as the material was so hard, the hammering not only cracked the material but even the dies themselves.

The operating principle of the machine consisted of striking a large number of overlapping blows to produce a smooth surface on the material worked as it was slowly passed through the dies. Having found that this procedure led only to failure, he decided to strike out for himself in an opposite direction. He found that with the ordinary swaging die each blow abstracted a certain amount of heat from the tungsten. The next blow, struck practically in the same place, hit the spot of tungsten that had become chilled below the most favorable temperature and cracked it. He designed some special dies that had but a small working face, and by feeding the rod through the machine at fairly high speed, he was able to prevent the blows from overlapping. This helped tremendously, and by specially shaping the face of the dies he was finally able to eliminate the trouble of twisting the work.

As a result he was enabled to carry a molybdenum (not tungsten) rod successfully through several dies without cracking, but then another difficulty appeared. He had been holding the heated rod in a pair of tongs, thrusting it into the swaging machine as rapidly as possible for half its length, and then withdrawing it. As a result, a number of blows which overlapped each other struck the middle of the rod, chilling it and producing cracks. To overcome this, he provided a very powerful brake by which he was able to stop the machine very suddenly when he had thrust the rod in as far as he thought desirable, thus slowing down the hammering action of the machine before he slowed down the motion of the rod. He then withdrew the rod, reheated it, and thrust the opposite end in the swaging machine. Later, however, as the art advanced as a result of his researches, it became possible to get along without the brake.

THE INCANDESCENT LAMP

Finally, he was able by this hot swaging process to reduce his original tungsten slugs, which were about $\frac{1}{4}$ to $\frac{3}{8}$ of an inch square and six inches long, to a rod having a diameter of about $\frac{1}{8}$ of an inch. However, from this point on, his difficulties increased enormously as the size of the rod decreased. As the rod decreased in diameter its length of course increased, increasing the number of blows that had to be struck, and a single blow struck under unfavorable conditions was sufficient to crack or break the rod. At this point the problem of bridging the interval between $\frac{1}{8}$ of an inch (or 125 mils—a mil is a thousandth of an inch) to 30 mils seemed almost impossible with a swaging machine. His original piece of ductile tungsten was made from a pressed filament of 25 mils drawn down through diamond dies, and diamond dies larger than 30 mils were not available. He tried chilled iron dies, using swaged molybdenum, but after passing it through several dies, it split up badly. He then tried drawing hot molybdenum through the dies but found it destroyed them.

His next step was to obtain a much smaller swaging machine that could be driven at a higher rate of speed, which permitted the work to be fed faster into the machine, the working face of the dies being still further reduced. A small tube furnace was placed in front of the machine and the work was fed from this directly into the machine by a pair of rolls running at a uniform rate of speed. As a result he was finally able to swage molybdenum, and later tungsten, down to 30 mils.

During this whole process the workability of the tungsten was being improved and at 30 mils it was found to be ductile. From this point on he was then able to draw the tungsten, which owing to its reduced size may now be called wire, through diamond dies by methods he had already used. This consisted of using hot dies; heating the wire; aqua dag lubricant which, at the suggestion of one of his assistants, was baked on the wire; small drafts; and a gradual reduction of temperature as the work proceeded.

THE INCANDESCENT LAMP

While he had now been able to make a fine drawn tungsten wire from a relatively large tungsten slug in the laboratory and with much patience, it did not mean that a commercial process had been developed to manufacture wire on a large scale. There were difficulties which had to be met, some tungsten slugs seemed capable of being mechanically worked, while others did not. Two lines of research were started, mechanical and chemical, both being carried along together.

The tungsten slugs had been heated in a gas forge. He tried heating them in an atmosphere of hydrogen and devised a special iron tube furnace for the purpose. This helped, as it was believed that the rods took up carbon or oxygen from the furnace gases and thereby lost much of their workability. Another difficulty then arose. Small shiny spots appeared on the slugs after they had been sintered in the treating bottle. After the first swaging, the metal in the neighborhood of these spots was found to be brittle. Samples of this brittle metal were analyzed and found to contain iron, which, it was decided, must have come from the walls of the iron tube furnace. This difficulty was overcome by placing the rods in carriers and embedding them in powdered silica. A vigorous stream of hydrogen gas was passed through the iron tube and in this way the vapor of any iron evaporated from the walls of the furnace was prevented from reaching the tungsten.

But there still was a lack of uniformity in the behavior of the various slugs. Some of them, as they came from their first heating in the iron tube furnace, shrank more than others when being sintered in the treating bottle, those which had shrunk least being the more easily worked. He thought that the ones that shrank most must have taken up some other impurity from the furnace, so he devised an electrically heated porcelain tube furnace. The first slugs fired in this furnace looked much better than anything seen up to that time. He then went on a vacation, leaving instructions to press up, heat in the porcelain tube furnace

THE INCANDESCENT LAMP

Finally, he was able by this hot swaging process to reduce his original tungsten slugs, which were about $\frac{1}{4}$ to $\frac{3}{8}$ of an inch square and six inches long, to a rod having a diameter of about $\frac{1}{8}$ of an inch. However, from this point on, his difficulties increased enormously as the size of the rod decreased. As the rod decreased in diameter its length of course increased, increasing the number of blows that had to be struck, and a single blow struck under unfavorable conditions was sufficient to crack or break the rod. At this point the problem of bridging the interval between $\frac{1}{8}$ of an inch (or 125 mils—a mil is a thousandth of an inch) to 30 mils seemed almost impossible with a swaging machine. His original piece of ductile tungsten was made from a pressed filament of 25 mils drawn down through diamond dies, and diamond dies larger than 30 mils were not available. He tried chilled iron dies, using swaged molybdenum, but after passing it through several dies, it split up badly. He then tried drawing hot molybdenum through the dies but found it destroyed them.

His next step was to obtain a much smaller swaging machine that could be driven at a higher rate of speed, which permitted the work to be fed faster into the machine, the working face of the dies being still further reduced. A small tube furnace was placed in front of the machine and the work was fed from this directly into the machine by a pair of rolls running at a uniform rate of speed. As a result he was finally able to swage molybdenum, and later tungsten, down to 30 mils.

During this whole process the workability of the tungsten was being improved and at 30 mils it was found to be ductile. From this point on he was then able to draw the tungsten, which owing to its reduced size may now be called wire, through diamond dies by methods he had already used. This consisted of using hot dies; heating the wire; aqua dag lubricant which, at the suggestion of one of his assistants, was baked on the wire; small drafts; and a gradual reduction of temperature as the work proceeded.

THE INCANDESCENT LAMP

While he had now been able to make a fine drawn tungsten wire from a relatively large tungsten slug in the laboratory and with much patience, it did not mean that a commercial process had been developed to manufacture wire on a large scale. There were difficulties which had to be met, some tungsten slugs seemed capable of being mechanically worked, while others did not. Two lines of research were started, mechanical and chemical, both being carried along together.

The tungsten slugs had been heated in a gas forge. He tried heating them in an atmosphere of hydrogen and devised a special iron tube furnace for the purpose. This helped, as it was believed that the rods took up carbon or oxygen from the furnace gases and thereby lost much of their workability. Another difficulty then arose. Small shiny spots appeared on the slugs after they had been sintered in the treating bottle. After the first swaging, the metal in the neighborhood of these spots was found to be brittle. Samples of this brittle metal were analyzed and found to contain iron, which, it was decided, must have come from the walls of the iron tube furnace. This difficulty was overcome by placing the rods in carriers and embedding them in powdered silica. A vigorous stream of hydrogen gas was passed through the iron tube and in this way the vapor of any iron evaporated from the walls of the furnace was prevented from reaching the tungsten.

But there still was a lack of uniformity in the behavior of the various slugs. Some of them, as they came from their first heating in the iron tube furnace, shrank more than others when being sintered in the treating bottle, those which had shrunk least being the more easily worked. He thought that the ones that shrank most must have taken up some other impurity from the furnace, so he devised an electrically heated porcelain tube furnace. The first slugs fired in this furnace looked much better than anything seen up to that time. He then went on a vacation, leaving instructions to press up, heat in the porcelain tube furnace

THE INCANDESCENT LAMP

and sinter in the treating bottle a hundred slugs which were to be ready for hot working experiments on his return.

On his return he found that none of the slugs could be worked, all breaking up in either the first or second swaging die. This puzzled him greatly, but he finally decided, after much investigation, that the trouble was caused by the presence of oxygen in the sintered slugs. He was using very fine tungsten powder which oxidizes to such an extent that it normally absorbs a relatively considerable amount of oxygen before it is moulded in the press. During the first heating of the slug in the iron tube furnace, the rods had been packed in silica and this finely divided material had hindered the escape of water vapor resulting from the action of hydrogen on the oxide of tungsten. The long continued heating in this atmosphere of water vapor had materially coarsened the tungsten powder and thus had made it possible to remove the oxygen before sintering had taken place. The porcelain furnace merely removed the oxygen from the surface of the slug, and after this had happened the surface sintered over imprisoning the balance of the oxygen. Dr. Coolidge then made some relatively coarse tungsten powder by melting tungsten oxide in a crucible, crushing the resulting mass, and reducing the oxide to tungsten. He then found that another chemist in the laboratory had, for some other purpose, heated some tungsten oxide in a "Battersea" crucible and also reduced it to a coarse tungsten powder. With these coarse powders he was able to get good results from slugs treated in the porcelain furnace, provided they were kept out of contact with the porcelain tube. Otherwise they would take up the glaze from the tube, which caused a net work of fine cracks to develop on the surface of the rods after they had been partially worked.

The problem of producing tungsten wire in quantity had now been solved, but lamp filaments made from this early wire "offset" badly when burned on alternating current. This was a difficulty which had also been found in the tantalum lamp. It was discovered, however, that

THE INCANDESCENT LAMP

wire made from the coarse tungsten powder produced from the oxide heated in the Battersea crucible did not offset. Dr. Coolidge reached the conclusion that the

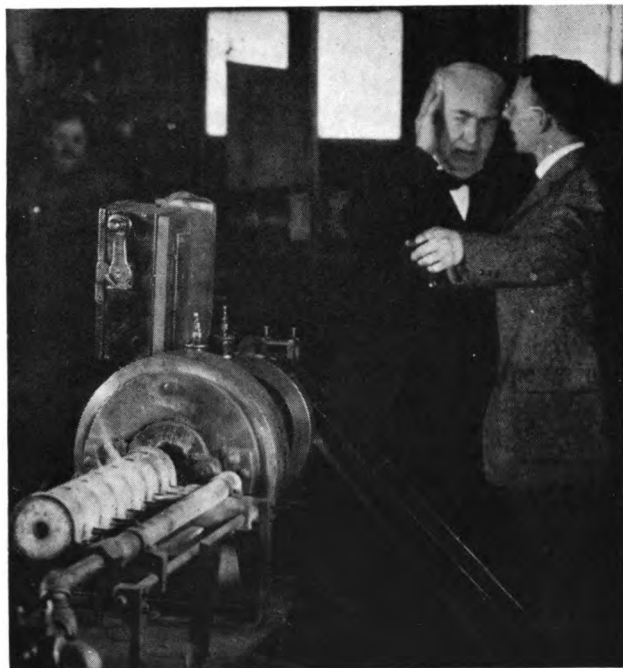

DR. COOLIDGE AND MR. EDISON, 1922

Dr. Coolidge showed Mr. Edison, when he visited the Research Laboratory in Schenectady in 1922, the swaging machine which he had developed and with which he was able to make tungsten ductile on a commercial scale.

tungsten had absorbed certain substances from the Battersea crucible which had some effect on the offsetting. After much experiment he found it possible to prevent offsetting by directly mixing the tungsten powder with small amounts of certain other substances.

THE INCANDESCENT LAMP

The Temperature of the Working

The temperature at which tungsten is worked is an important part of Dr. Coolidge's invention. With other metals, except in the special case of molybdenum, working below the annealing temperature will always reduce ductility. The reverse is true with tungsten; its ductility is created by working it below its annealing temperature.

Whenever any of the other metals has been worked hot, above its annealing temperature, it has been because it was easier and cheaper to give it the desired form at that temperature, or it was desired to secure the superior mechanical properties associated with the "fine grained," structure, or, by working it at or above its annealing temperature, it was possible to work and anneal at the same time thus avoiding a special annealing process.

The actual annealing temperature of tungsten becomes lower the greater the amount it is worked below its annealing temperature. Tungsten can be worked above its annealing temperature, but its ductility is destroyed and it will revert to its crystalline state, becoming brittle when cool. The working range is from about 1650 degrees C., a high white heat, down to about 350 degrees C., which is below a dull red heat; the more the metal is worked, the lower the working temperature. The initial working operations must be carried on at high temperature, otherwise the tungsten would break in pieces on account of its brittleness at low temperature. The high temperature also reduces its hardness.

The fact that heating to temperatures above the annealing temperature destroys the effect of previous working was utilized in a curious and interesting way. After it had been discovered how to make an ingot of tungsten that could be swaged and worked down to small diameters, there was found a tendency for the tungsten to split longitudinally at some stage of the process, usually before the wire had been brought down to the desired size. It split up into a bundle of fibers almost like the fibers of a hemp rope. A certain amount of working the tungsten is

THE INCANDESCENT LAMP

good, but too much working spoils it, so the object was to subject it to that certain amount of working and then stop. As various sizes of wire are necessary for the various wattages and voltages of lamps, the exact amount of working was accomplished by the simple expedient of reducing the standard size ingot to one of a particular size under conditions which would not change its internal structure to any considerable extent, and then properly work it down to the size of wire desired.

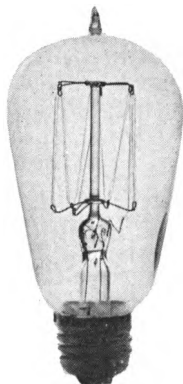

DRAWN TUNGSTEN WIRE LAMP, 1911

Dr. Coolidge's invention of drawn tungsten wire materially simplified the manufacture of the tungsten filament lamp and greatly increased its ruggedness.

Announcement and Adoption of Drawn Tungsten Wire

Dr. Coolidge's success in being able to make ductile tungsten was announced in March, 1910. In 1914, he was awarded the Rumford Medal by the American Academy of Arts and Sciences for his scientific triumph. This is perhaps the highest recognition of the sort to which an American scientist can aspire, the medal being granted for the most important discovery or useful improvement in heat or light. A patent was granted to Dr. Coolidge in December, 1913.

THE INCANDESCENT LAMP

The making of tungsten filaments was changed over to the drawn wire process, beginning with the latter part of 1910. In the early part of 1911, the drawn wire lamps were put on the market. Over half a million dollars' worth of the pressed filament apparatus had to be scrapped, as well as nearly another half million dollars' value of unsold pressed filament lamps.

Drawn tungsten wire filaments are very strong, and consequently the lamp is very sturdy, a marked improvement over the fragile pressed filament lamp. The lamp is, therefore, much more practicable and the breakage in shipment is reduced. The enormous increase in the strength of the filament greatly increased the use of the lamp under such severe conditions as those met within its application to automobiles, street railway and steam railroad cars, etc. Drawn wire filaments are much cheaper to make than pressed filaments, so that it became possible to materially reduce the price of the lamps. Drawn wire can be readily coiled, which greatly simplified the manufacture of concentrated filament lamps for focusing purposes.

Ductile tungsten can be drawn to such an exact diameter and cut to the desired length so accurately that practically all lamps made are of the voltage and efficiency for which they are designed. In fact the variation in voltage is so small that these lamps are not photometered, as all previous kinds of lamps had to be, to determine their voltage. Sample lamps are constantly tested for voltage and efficiency, and these tests show that lamps as made today vary less in voltage and efficiency than previous lamps, even after the latter had been tested and sorted for voltage. Thus the necessity for a multiplicity of voltages because of the variations in lamps was eliminated, all lamps could, if desired, be made for a single voltage. As it seemed impractical for all plants to readjust their voltage to one standard, three standard voltages, 110, 115 and 120 volts, have been adopted. At present more than 90 per cent of the standard lighting lamps are of these three voltages, and the stock necessary to properly supply the demand has been greatly simplified.

THE INCANDESCENT LAMP

In the usual sizes of lamps the filament is of such a small diameter, a few thousandths of an inch, that it is impossible to determine the diameter accurately by a micrometer. It is accurately measured, however, by weighing a definite length, a few inches of the wire, in a sensitive torsion balance, which will determine its weight and hence, by calculation from its specific gravity, its diameter, to within three millionths of an inch.



OFFSET TUNGSTEN FILAMENT

After a filament has been lighted for the first time it has a crystalline structure. If the faces of the crystals fall in one plane across the diameter of the filament, offsetting may occur.



THORIA PREVENTS OFFSETTING

This high magnification photomicrograph shows the thoria globules which tend to key the crystals together, preventing offsetting.

Non-Sag Drawn Tungsten Wire

When a lamp is first lighted, the long fibrous grains of the drawn wire, heated above their annealing temperature, are changed to the equiaxed grains of an annealed metal. These grains, during this transition, absorb each other, gradually increasing in size until further growth is retarded or stopped. The cessation of growth of the grains may be attributed to several causes, not the least of which is the presence of impurities in the metal.

THE INCANDESCENT LAMP

The crystals composing the wire are, to the best of present knowledge, held together by amorphous tungsten. This material acts as a binder to hold them together and in place, but, at very high temperatures, it is not as rigid as the crystals themselves, consequently the positions of the latter may become altered.

Should the faces of one or more crystals fall in one plane across the diameter of the filament, offsetting will occur, that is, sections of the filament will slide sidewise and it will soon burn out due to the decrease in cross-section at this point. Fairly small crystals with minute



Sag Wire



Non-Sag Wire

CRYSTAL GROWTH IN TUNGSTEN FILAMENTS

By removing nearly all the slight amount of impurities in a tungsten filament, the crystals become long and overlap and so make a sag-resisting wire which does not offset. The sag-resisting feature is of great advantage in coiled filament lamps.

particles of thoria, which is hard at the high temperature, will retard offsetting, the thoria particles tending to key the crystals together.

The thoriated wire, however, bends easily at this high temperature due to the fact that the proportion of amorphous material present is greater than that in a large grained wire. Thus, if the crystals could be allowed to grow to a large size, there would be relatively less of the amorphous tungsten present and, if these crystals overlapped

THE INCANDESCENT LAMP

and interlocked with each other, a wire should be produced which would remain stiff and would not readily sag nor offset at high temperature.

Dr. Aladar Pacz, of the General Electric Company, made a study of this. He reasoned that if it were possible to get rid of the minute impurities and eliminate the use of thoria, a wire of large overlapping crystals might be obtained which would neither sag nor offset. It might be possible to get rid of these impurities by purposely inserting certain substances. These substances should not vaporize at the relatively low temperatures at which the moulded tungsten slug is given its preliminary heating in hydrogen gas, but should readily vaporize at the relatively high temperature at which the slug is sintered in the treating bottle by a heavy electric current. Thus the substances, coming out of the slug as it is being sintered, might carry with them the minute impurities it was desirable to get rid of.

Dr. Pacz tried mixing various substances with the tungsten powder, and after many experiments finally evolved a process, by which tungsten is produced in apparently such a pure state that the wire filament, made by Dr. Coolidge's process, when lighted for the first time, immediately crystallizes in such large overlapping crystals that it does not materially sag or offset. The crystals are many hundred times larger than those of thoriated wire.

In a MAZDA C (gas-filled) lamp it is most important that the coiled wire should not sag materially. If it does, part of the helix opens up, allowing the gas to more readily circulate between the turns of the helix and thus cool the wire to a greater extent. This lowers the temperature of the filament, reducing its candle power and efficiency. Certain turns of the helix tend to sag together, and if the turns touch each other they short circuit themselves. Dr. Pacz's invention was, therefore, of great value in the MAZDA C lamp, so that it not only considerably improved the maintenance of candle power of the lamp during its life but also increased its average efficiency throughout life.

THE INCANDESCENT LAMP

Non-sag wire is used only in coiled filament lamps. In the straight filaments used in some vacuum lamps, the bends of the filament around the anchors operate at a much lower temperature due to the conduction of heat away from the filament at these places. As a consequence the filament does not sag at the bends.

•

CHAPTER FOUR

THE VACUUM, "GETTERS", AND THE GAS-FILLED LAMP

THE VACUUM

The vacuum was one of the elements of Edison's original lamp and still is in the majority of lamps made today. In the early days of lamp manufacture all lamps were exhausted on Sprengel mercury pumps, which consisted of a glass "fall" tube down which mercury was allowed to fall. The fall tube was connected at the top to a branch tube, one end of which was connected to the lamp to be exhausted, the other end being connected to the upper reservoir of mercury. The mercury trapped bubbles of air from the lamp and its weight forced the bubbles down and out of the end of the fall tube, which dipped into the lower reservoir of mercury. The mercury from the lower reservoir was pumped back to the upper by an Archimedes screw pump.

A very high degree of vacuum is necessary in a vacuum lamp, but, since it is impossible to produce an absolute vacuum, the degree of vacuum is measured by the pressure of the residual gases in the bulb. Atmospheric pressure at sea level is about fifteen pounds per square inch which is equal to the weight of a column of mercury about 760 millimeters high. The degree of vacuum is measured in microns, a micron being one-thousandth of a millimeter, and in modern lamps the degree of vacuum is often less than one micron mercury pressure, or about a millionth of that of the atmosphere at sea level.

In June, 1881, it took five hours to exhaust a lamp, each operator taking care of about fifty pumps, with one lamp

THE INCANDESCENT LAMP

on each pump. The chief difficulty was then and still is getting the moisture, in the form of water vapor, out of the lamp bulb. This moisture adheres to the surface of the glass and the glass must be heated to liberate it. No matter how hot the bulb is heated, more moisture will be liberated if the bulb is heated still hotter, so the bulbs must be heated

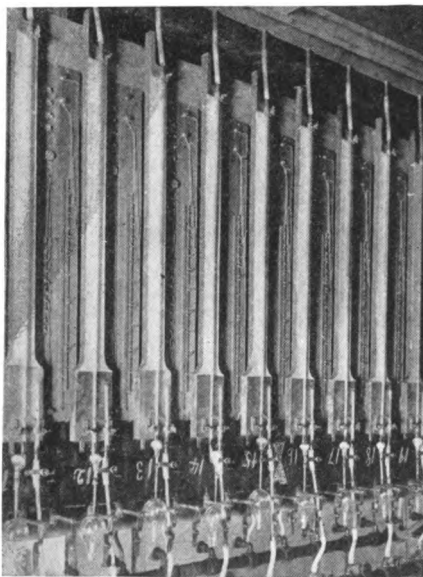

SPRENGEL VACUUM PUMPS

Mercury, dropping down the "fall" tube, trapped bubbles of air and so exhausted a lamp. This originally required five hours. Improvements reduced the time to thirty minutes.

during exhaustion, or just before it, hotter than they will ever become in use. In practice they are heated to about 300° C.

After the moisture is liberated it must be removed from the bulb. The mercury pumps would not draw it out, so from the beginning it was absorbed by phosphoric anhy-

THE INCANDESCENT LAMP

dride which was held in a small glass cup attached to the pump. In the early days this phosphorus cup was not close enough to the lamp and the absorption of moisture had to take place through five or six inches of glass tubing. This was one reason for the long time required to exhaust lamps in 1881. Later this condition was improved, the dryer being put as close as possible to the lamp, about $2\frac{1}{2}$ inches, and this shortened the time of exhaust a great deal.

The vacuum pump itself was much improved, larger tubing being used so that the pump required three times as much mercury to operate it. The contraction which limited the flow of mercury to the pump was changed from glass to iron. Glass contractions got dirty and gradually reduced the flow of mercury, but iron did not get dirty and kept the pumps working at full capacity. All these changes ultimately reduced the time required to exhaust a lamp to thirty minutes.

The copper plated filament connections and carbon paste connections liberated a good deal of gas when heated. Before the vacuum became good there came a stage in which it was conductive. In this condition, when the filament was burned at high temperature, this cross current, passing through the partial vacuum and creating a blue glow in the bulb, heated the filament connections red hot and drove the gas out. The carbon filaments themselves gave out very little gas when heated.

The condition of the vacuum in the Sprengel mercury pumps was indicated by the size of the bubbles of gas passing down the fall tube of the pump. As the vacuum improved these bubbles got smaller and smaller until they could not be seen. This condition was known as a solid tube, the tube being filled with mercury with no bubbles showing in it. This was the indication of a good vacuum and the lamp was then sealed off. A solid tube indicated a vacuum of one thousandth of an inch (about forty microns) of mercury pressure or less. These mercury pumps were used from the beginning until 1896, when the Malignani chemical exhaust process was introduced.

THE INCANDESCENT LAMP

Malignani Chemical Exhaust

Arturo Malignani was a home made engineering genius. He lived in the town of Udine, in the northern part of Italy, right at the foot of the Austrian Alps, where he built an electric lighting plant for the town and made his own electric lamps. He did not have mercury pumps and his mechanical pump would not make a good enough vacuum, about one millimeter (1000 microns) mercury pressure being the best he could get. He made the great discovery that, when he had this poor vacuum in a lamp, if he liberated phosphorus

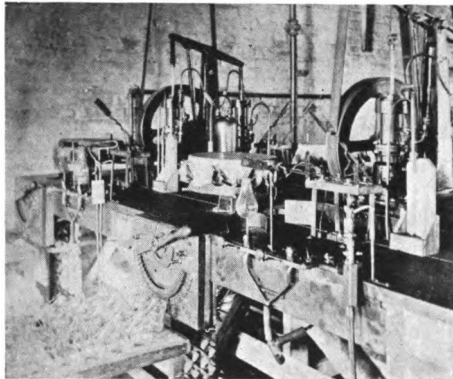

MALIGNANI CHEMICAL EXHAUST, 1896

This chemical method of improving a relatively poor vacuum, quickly obtained by a piston vacuum pump, to the high degree required in a lamp, reduced the time of exhaust from half an hour to less than two minutes.

vapor in the lamp while the filament was burning at high incandescence and the bulb was full of blue glow, the glow suddenly disappeared and a high vacuum was produced.

Malignani painted the inside of the exhaust tube of the lamp with red phosphorus. Then, when the filament was raised to high incandescence and the bulb was full of blue glow, he closed the connection between the pump and the

THE INCANDESCENT LAMP

lamp and heated the exhaust tube enough to vaporize the phosphorus. This drove the vapor inside the lamp, the blue glow disappeared and a good vacuum resulted.

This invention revolutionized the art of lamp exhaustion. The General Electric Company bought Malignani's U. S. patent, and adopted this method of exhausting lamps. It enabled one operator with one pump to exhaust a lamp a minute with more uniform result than could be produced by the old method which required thirty minutes.

THE "GETTERS"

Before the expiration of the Edison lamp patent in 1894, the Waring Electric Lamp Company marketed lamps called "Novak Lamps" which, instead of having a high vacuum, had a small amount of bromine vapor in the bulbs, usually about $1\frac{1}{2}$ millimeters (1500 microns) mercury pressure. This bromine very materially reduced the discoloration, and that which did occur was greenish and not black. It is believed that the carbon molecules thrown off from the incandescent filament combined with the bromine vapor to form the greenish compound on the bulb. The bromine was gradually used up and, after a few hundred hours burning, the lamp had good vacuum. This bromine was what is now called a "getter" and this was the first, though unrealized, use of a getter.

When the Edison patent expired, the manufacture of this lamp was abandoned in favor of the high vacuum lamp. The Novak lamp was invented by John Waring, who supervised its manufacture. He was a man of unusual character and promise, and his death, which was due to an explosion in his laboratory, was deeply regretted by all who knew him.

The word "getter" is now applied to any active agent used inside the bulb, either to assist in getting a vacuum, or to improve the quality of the lamp, usually by preventing the blackening of the bulb.

The use of phosphorus to improve the vacuum, invented by Malignani, has already been described. The

THE INCANDESCENT LAMP

Malignani Chemical Exhaust

Arturo Malignani was a home made engineering genius. He lived in the town of Udine, in the northern part of Italy, right at the foot of the Austrian Alps, where he built an electric lighting plant for the town and made his own electric lamps. He did not have mercury pumps and his mechanical pump would not make a good enough vacuum, about one millimeter (1000 microns) mercury pressure being the best he could get. He made the great discovery that, when he had this poor vacuum in a lamp, if he liberated phosphorus

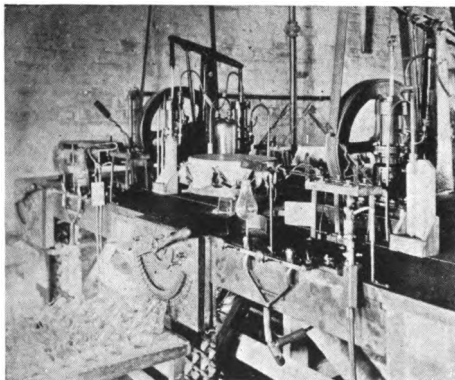

MALIGNANI CHEMICAL EXHAUST, 1896

This chemical method of improving a relatively poor vacuum, quickly obtained by a piston vacuum pump, to the high degree required in a lamp, reduced the time of exhaust from half an hour to less than two minutes.

vapor in the lamp while the filament was burning at high incandescence and the bulb was full of blue glow, the glow suddenly disappeared and a high vacuum was produced.

Malignani painted the inside of the exhaust tube of the lamp with red phosphorus. Then, when the filament was raised to high incandescence and the bulb was full of blue glow, he closed the connection between the pump and the

THE INCANDESCENT LAMP

lamp and heated the exhaust tube enough to vaporize the phosphorus. This drove the vapor inside the lamp, the blue glow disappeared and a good vacuum resulted.

This invention revolutionized the art of lamp exhaustion. The General Electric Company bought Malignani's U. S. patent, and adopted this method of exhausting lamps. It enabled one operator with one pump to exhaust a lamp a minute with more uniform result than could be produced by the old method which required thirty minutes.

THE "GETTERS"

Before the expiration of the Edison lamp patent in 1894, the Waring Electric Lamp Company marketed lamps called "Novak Lamps" which, instead of having a high vacuum, had a small amount of bromine vapor in the bulbs, usually about $1\frac{1}{2}$ millimeters (1500 microns) mercury pressure. This bromine very materially reduced the discoloration, and that which did occur was greenish and not black. It is believed that the carbon molecules thrown off from the incandescent filament combined with the bromine vapor to form the greenish compound on the bulb. The bromine was gradually used up and, after a few hundred hours burning, the lamp had good vacuum. This bromine was what is now called a "getter" and this was the first, though unrealized, use of a getter.

When the Edison patent expired, the manufacture of this lamp was abandoned in favor of the high vacuum lamp. The Novak lamp was invented by John Waring, who supervised its manufacture. He was a man of unusual character and promise, and his death, which was due to an explosion in his laboratory, was deeply regretted by all who knew him.

The word "getter" is now applied to any active agent used inside the bulb, either to assist in getting a vacuum, or to improve the quality of the lamp, usually by preventing the blackening of the bulb.

The use of phosphorus to improve the vacuum, invented by Malignani, has already been described. The

THE INCANDESCENT LAMP

phosphorus was never called "getter" in connection with Malignani's chemical exhaust.

In 1908 or 1909, John T. Marshall invented the present-day method of exhausting tungsten filament lamps without lighting the filament. He coated the filament and mount by dipping the mounts in a mixture of phosphorus and water. After the lamps were sealed off, the filament was burned at high incandescence; a blue glow appeared, and a good vacuum resulted.

Phosphorus is now used as a getter to assist in getting the vacuum in all vacuum lamps, it being applied to the filament as a coating. After sealing off the lamp, this coating of getter is vaporized by flashing the filament to a bright incandescence. At this time, a blue glow appears in the bulb for about a second. Disappearance of the blue glow is always associated with "clean-up," or reduction in pressure. The explanation of the formation of blue glow is somewhat as follows: Under the influence of the voltage applied across the filament, electrons emitted from the negative end of the filament are accelerated with appreciable velocity toward the positive end. If there are present sufficient residual gas molecules, a large number of collisions occur between electrons and gas molecules with the consequence that the molecules are ionized; that is, they are dissociated into an electron and a positively charged residue (positive ion). These separated parts naturally tend to recombine, and during the process of recombination, radiation is emitted, which is perceived as blue glow.

The action of phosphorus in getting the vacuum, or in "cleaning-up" the lamp as it is called, is not perfectly understood, but it is believed to act in two ways. The phosphorus vapor combines chemically with oxygen and water vapor, and the products of these combinations are carried to the bulb and held there. It is also believed that the phosphorus, which has condensed on the bulb under the conditions which exist when the filament is at intensive incandescence and blue glow is in the lamp, adsorbs other gases with which it does not combine chemically, and holds

THE INCANDESCENT LAMP

them on the bulb. These gases may be subsequently liberated in their original condition if the lamp bulb is heated hot enough to vaporize the phosphorus.

Many experiments have been tried to determine the nature of the action of these getters, and some evidence, although it is not conclusive, has been obtained. The residual gases in vacuum lamps, after sealing off, are, on the average, about 25 microns. In gettered lamps, this pressure will be reduced to less than one micron when the lamp has burned for a few seconds, provided the applied voltage is high enough. In lamps below forty volts, the reaction is much slower, and may be of a different nature. There is evidence that the reaction of the getter with the residual gas is not predominantly chemical, since such getters as phosphorus, silica, aluminum or manganous oxide will, when applied to the filament as a getter, clean up such gases as hydrogen, nitrogen, carbon monoxide, carbon dioxide, oxygen, water vapor, and to a lesser degree, argon, at about the same rate, and to about the same residual pressure, regardless of which getter or gas is used. Chemical action probably takes place between phosphorus and oxygen, and also water vapor. In addition to any action which may take place in the vapor phase, probably the most important reaction takes place on the bulb wall. When the lamps with phosphorus, silica, aluminum or manganous oxide getter are burned, the getter having been thrown to the bulb wall and the gas having been cleaned up, a second clean-up can be obtained by admitting a small quantity of gas and again flashing the lamp. Only a limited quantity of gas can be made to disappear on a single coating of getter in this manner. It is believed that phosphorus has a continuing action during the life of the lamp in case any water vapor is liberated in its interior.

The general conclusion is that the vacuum clean-up must be largely an adsorption, by the getter on the bulb wall, of gases activated in some manner by an electrical

THE INCANDESCENT LAMP

discharge of sufficiently high voltage. It is believed that the action of the phosphorus getter is solely to get and keep the vacuum, as it acts on gases only.

There is another kind of getter used in all tungsten filament vacuum lamps, the action of which is not to get or maintain the vacuum, but is to reduce the blackening of the lamp. This getter is usually a fluoride, and is now applied to the filament as a coating. In practice, it is mixed with phosphorus, and the mixture is put on the filament.

When the lamp is flashed after exhaustion the getter vaporizes and condenses on the bulb, where it remains. During the life of the lamp, molecules of tungsten fly from the hot filament to the bulb and slowly blacken the bulb, but the coating of getter reduces this blackening very much.

The reaction to prevent blackening by fluoride is shown to take place on the bulb wall by placing a small piece of glass, about the size of a dime, on the inside of the lamp, and letting it protect one small spot on the bulb from a deposit of getter while the lamp is being flashed. The small piece of glass is then removed to some other location and the lamp burned for several hours. The spot where the glass rested when the lamp was flashed will blacken much more rapidly than the remainder of the bulb due to the absence of getter at that point. This black spot has sharply defined edges, and has the same shape and size as the protecting glass. One explanation of prevention blackening is due to some optical experiments at the Philips Lamp factories at Eindhoven, Holland. The result of these experiments indicate that the particles of vaporized tungsten are held in a sort of colloidal suspension in the getter, and in this condition will not absorb so much light as if allowed to agglutinate and form a continuous layer. Some engineers think that this is due, in part at least, to chemical action.

A third class of getters was formerly used to a considerable extent, but is little used now. These getters were placed in a cavity in the glass filament support, where the

THE INCANDESCENT LAMP

heat caused them to give off a continuing supply of gas. Different materials have been used, some of which give off gases, such as oxygen, or a halogen gas, which combine with the vaporized tungsten to form a light colored deposit on the bulb. Barium chlorate is an example of an oxygen getter. This is used today in vacuum series lamps, which is the only use today of a getter of this class.

A little oxygen has a beneficial getter action in either carbon, tantalum or tungsten lamps. In all these lamps, oxidized copper supports which slowly liberated oxygen, gave better results than supports made of non-oxidized metal.

Other getters of this third class yield gases which are halogen compounds, and which have a regenerative action, combining with the vaporized tungsten, carrying it back and depositing it on the filament. Tungsten oxychloride is a regenerative getter. Potassium thallium chloride is another. The latter was used commercially for a long time on some lamps. When the temperature condition of the getter was right, the lamps remained clear and did not change in resistance or candle power. But temperature conditions varied so much that the lamps gave variable results, and the getters are no longer used.

Getters are also used in gas-filled lamps. Phosphorus is used in gas-filled lamps, being applied to the filament as in vacuum lamps, and, when vaporized, combining with the water vapor and oxygen in the lamp, thus purifying the gas with which the lamp is filled. Carbon and carbon compounds are also used as getters in gas-filled lamps. They are applied to the filaments in the same manner as a phosphorus getter. Both getters take care of water vapor and oxygen—the phosphorus possibly has a continuing action during the life of the lamp. The action of the carbon, however, will cease when all of the carbon has been removed from the filament.

Barium ozoamid is used by one European lamp manufacturer in gas-filled lamps. It prevents blackening by the liberation of nascent nitrogen which is very active in com-

THE INCANDESCENT LAMP

binning with vaporized tungsten and water vapor. This getter is decomposed by heat when, after the lamp has been exhausted, it is flashed high in the gas.

Skaupy's Getter

Franz Skaupy, an Austrian chemist, invented the use of getters in metal filament lamps to lessen the blackening of the bulb caused by the deposit of the filament material

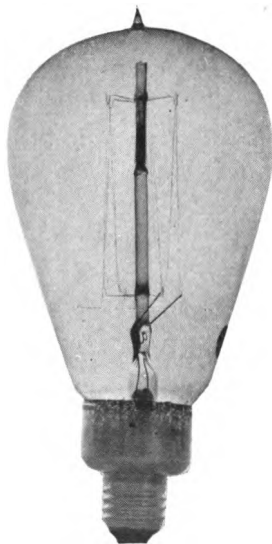

TUNGSTEN LAMP WITH SKAUPY'S "GETTER," 1912

The chemicals called "getters," in the hollow end of the glass rod supporting the filament, vaporized as the lamp burned, reducing the blackening of the bulb.

on the bulb. Skaupy's idea was to use chemicals in the lamp which would convert this black deposit into one of a lighter shade, so that less light would be cut off from the filament during the life of the lamp. The chemicals as used by Skaupy did not improve the vacuum; on the contrary a gas was purposely formed in the bulb as the lamps burned. This was opposite to what lamp engineers considered desirable, as the belief was that nothing should be done to

THE INCANDESCENT LAMPS

impair the vacuum. Skaupy's invention is, therefore all the more meritorious. He applied for a U. S. patent which was granted in November, 1915.

In Skaupy's getter certain chemical compounds of the halogen group of elements (fluorine, bromine, iodine, chlorine) are put inside the bulb and remain there after the manufacture of the lamp has been completed. These compounds will break up when heated, releasing some of the atoms of the halogen element used, the rate of release depending on the temperature and pressure.

For example, with thallic chloride (which was commercially used) chlorine gas is evolved which will combine with tungsten, forming tungsten chloride, which is lighter in color than tungsten itself. If the chlorine gas is evolved at the proper rate by heating the thallic chloride to the proper temperature, it will combine with the tungsten which evaporates from the filament as the lamp burns, without attacking the tungsten filament itself. If it evolved too slowly, the deposit will contain black tungsten, as an insufficient quantity of chlorine gas is evolved to combine with all of the tungsten which vaporizes. If evolved too fast, the tungsten filament itself will be attacked, thereby shortening the life of the lamp. It is, therefore, important that the thallic chloride getter be kept at a given temperature as the lamp burns.

This was accomplished by inserting the getter in a cavity in the end of the glass arbor supporting the filament anchors, the upper end of the arbor being made of glass tubing. The getter was held in place by glass wool, and the end of the tube constricted to prevent the getter and wool from dropping out.

In actual practice a double halogen compound was used, potassium thallic chloride, a chemical combination of two salts, potassium chloride and thallic chloride. Thallic chloride readily absorbs water vapor and was apt to do so before it was put in the lamp. Water vapor is very detrimental in a lamp, as it causes the lamp to blacken rapidly. The double chloride compound does not easily absorb water vapor.

THE INCANDESCENT LAMP

The use of getters was particularly desirable in the larger sizes of lamps, since such lamps blacken to a greater extent during their life than those of the lower wattages. This is because the relation of bulb surface to filament surface becomes smaller in the higher wattage lamps, causing a denser deposit on the bulb. Skaupy's getter was, therefore, used on the 100-watt and larger sizes of 110-volt types of lamps. It was also found that his getter was so active that it was impractical to use it in lower wattage lamps, as it could not be prevented from attacking the filament.

It is an expensive manufacturing proposition to make a hollow arbor to hold the getter. This method and its location was found to be the only practical one with this getter in order that it should reach the proper temperature. Many investigations were made to see if other chemical compounds could be used with simpler manufacturing construction, or to permit taking advantage of similar chemical reactions in lower wattage lamps.

Dr. Fink's Potassium Iodide Getter

Dr. Colin G. Fink invented a getter which was used in 1912 in the smaller sizes of lamps, namely those of 15 to 40 watts for 110-volt circuits. It consisted of potassium iodide mixed with water, a drop of which was put on the end of the glass arbor holding the filament, after which the drop was dried by baking the mounted filament in an oven before the mount was sealed in the bulb.

Potassium iodide is not as active as thallic chloride, but was commercially suitable for the lower wattage lamps, although it was impractical for use on 60-watt and larger lamps. During the life of the lamp, the iodide is decomposed by the heat from the filament, iodine vapor being released which combines with the vaporizing tungsten, forming a light colored deposit in the bulb.

Needham's Getter

Harry H. Needham, of the General Electric Company, invented a getter which was more active than Dr. Fink's, but less so than Skaupy's, and was suitable for 25- to 60-watt.

THE INCANDESCENT LAMP

110-volt lamps in which it was used. A patent was applied for in October, 1912, and granted in June, 1916, covering the method of application and use of double halogen salts, such as cryolite, which is a combination of sodium and aluminum fluoride, and which was commercially used.

The double salt was mixed with a binder, such as water glass, a drop of which was put on the anchors supporting the filament, care being exercised that the getter did not

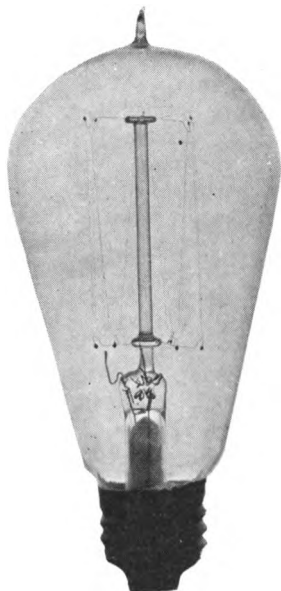

TUNGSTEN LAMP WITH NEEDHAM'S GETTER, 1912

This method of application greatly simplified the lamp construction. The chemicals used made the getter practicable in smaller sizes of lamps.

touch the filament, as otherwise it would cause the filament to fail at the point of contact. The getter was then dried by baking the filament mounts in an oven before they were put in the bulb. During the life of the lamp, the heat

THE INCANDESCENT LAMP

from the filament decomposed the cryolite releasing fluorine gas, which combined with the vaporizing tungsten, forming a light colored deposit.

Red phosphorus was mixed with this getter, the lamp being exhausted and sealed off without lighting the filament. After the base had been put on, the lamp was slowly lighted for the first time by gradually increasing the voltage applied to it. This is called "flashing," and by this means the red phosphorus in the getter became heated and vaporized, improving the vacuum in accordance with Malignani's scheme as previously described.

Friederich's Oxygen Getter

Ernst Friederich, a German, invented a getter consisting of an oxygen compound, barium chlorate being commercially used. He applied in June, 1913, for a patent in this country, which was granted in September, 1917. The barium chlorate was later mixed with manganese dioxide which acted as a catalyzer; that is, it assisted in breaking up the barium chlorate so that it would give up oxygen gas when heated. Red phosphorus was also mixed with this getter as in Needham's scheme, but the getter was located in the hollow end of the glass arbor supporting the filament anchors as in Skaupy's construction. It was used in lamps of 150 watts and above and is now used in vacuum series lamps.

The oxygen gas, released by the heat of the filament, which decomposed the barium chlorate, combined with the vaporizing tungsten, forming a light colored deposit.

Gill's Invisible Getter

Frederic W. Gill, of the General Electric Company, applied for a patent in June, 1915, which was granted in November, 1918, covering a getter which could be applied directly to the filament. The first getter commercially used, superseding Needham's getter, was ordinary table salt (sodium chloride) dissolved in water and sprayed on the mount. Red phosphorus was included in the getter as in Needham's scheme. When the lamp was lighted for the first time, the sodium chloride immediately vaporized from the filament and condensed on the walls of the bulb in an invisible layer.

THE INCANDESCENT LAMP

Care had to be exercised not to spray the mount too much, as too great an amount of the solution would cause the bulb to become iridescent. This led to the development of another method now used, also covered by patent, of putting the getter on the filament in such a way that the amount put on could be more accurately controlled.

A fluid mixture consisting of either sodium iron fluoride or cryolite (sodium aluminum fluoride) is made with red phosphorus and gun cotton, the latter dissolved in alcohol, ether and amyl-acetate. The drawn tungsten wire, before it is put on the anchors, is run through this paste, which forms a coating on the wire. The coated wire is then run through a plain solution of gun cotton to give it a further protective coating which dries and hardens on the wire.

THE GAS-FILLED LAMP

Dr. Irving Langmuir joined the staff of the Research Laboratories of the General Electric Company at Schenectady in 1909, while they were in the midst of Dr. Coolidge's invention of ductile tungsten and its application to incandescent lamps. One of the troubles, as has been explained, was the curious phenomenon of "offsetting," a tendency for the filament to divide into little sections of short length which slid sidewise over each other. Dr. Langmuir undertook a study of this phenomenon, which led him to a study of the gas given off by a tungsten filament at very high temperatures.

The necessity of a high degree of vacuum appeared to be of even greater importance in a tungsten than in a carbon filament lamp. The candle power given out by a lamp during its life decreases as it burns, the decrease being mainly due to blackening of the bulb caused by material leaving the filament, depositing on the inner surface of the bulb, and thus shutting off the light emitted by the filament. It was believed that the blackening of the bulb might be caused by slight traces of gases in the bulb, the rapid motion of the gas molecules striking the surface of the filament causing its

THE INCANDESCENT LAMP

disintegration. Some engineers thought that the disintegration might be due to chemical or electrical action of the gases and others thought it might be due to true evaporation.

Study of the Residual Gases in a Vacuum Lamp

It appeared, therefore, that a study of these traces of gases in the bulb was desirable, as their elimination might improve the lamp. Attempts to improve the lamp by obtaining a better vacuum than usual had not been very successful, and while it appeared that in operating a filament at its normal temperature, the vacuum gradually improved to a point better than that directly obtainable by any known method of exhaust, there were clear indications that undue blackening was caused by imperfect exhaust. The faint traces of residual gases were in such minute quantities that their pressure was less than that possible of measurement with the most sensitive vacuum gauge. The failure to improve the lamp by a new method of exhaust might mean that the vacuum had not been improved, since the pressures were too low to measure.

The residual gases in the bulb, after it has been exhausted to about one micron or less, were found to consist of water vapor, oil (hydrocarbon) vapors, carbon monoxide, carbon dioxide and hydrogen. By operating a filament above its normal temperature, more gases come out, and it was found that these gases not only came from the filament but the heat caused gases to come out of the anchors, leading-in wires and the glass as well. The actual gases from the filament were found to be small in quantity, as later work showed that the apparently inexhaustible supply of gas from within the filament was produced by its decomposing the water and hydro-carbon vapors present at extremely low pressures in the bulb. The actual gases from within the filament were mainly carbon monoxide and small amounts of hydrogen and carbon dioxide. The gases from the anchors and leading-in wires were also small in quantity. If the bulbs were externally heated so as to obtain higher temperatures than

THE INCANDESCENT LAMP

that received from the filament, large quantities of gases were driven out from the glass. These gases were mainly water vapor, a small amount of carbon dioxide and a still smaller amount of nitrogen.

The determination of these gases was a great achievement, as it was necessary for Dr. Langmuir to devise special apparatus to make qualitative and quantitative analyses for the determination of five different gases from but one cubic millimeter of total volume. Heretofore, it had been impossible to make determinations when such small quantities were involved.

Small quantities of various gases, up to about a tenth of a millimeter pressure, were then put into lamps to study their effect. Hydrogen was found to dissociate, that is, the molecules of hydrogen broke up into their two atoms, in which condition the gas is chemically very active. Dry hydrogen did not have the slightest tendency to blacken the bulb. Oxygen combined with the hot filament, forming an oxide which coated the bulb with an invisible layer, but it did not cause blackening. Nitrogen did not attack the filament, but it combined with the tungsten which evaporated from the filament, changing the deposit from black to brown. Carbon monoxide behaved almost exactly like nitrogen and thus could not be responsible for blackening. Carbon dioxide attacks the filament, producing an oxide of tungsten, the carbon dioxide reducing to the monoxide, but without blackening the bulb.

Water vapor, even at very low pressures, was found to produce blackening. This was surprising, as neither of its constituents, hydrogen and oxygen, acting alone, produces blackening. The explanation seems to be that the water vapor, coming in contact with the hot filament, is decomposed, the oxygen combining with the tungsten which deposits on the bulb. The chemically active atomic hydrogen formed attacks the tungsten oxide deposit, and reduces it to metallic tungsten, forming water vapor again. This cycle may be repeated indefinitely, so that a small quantity of water vapor will quickly blacken the bulb.

THE INCANDESCENT LAMP

The effects of many other gases and vapors were studied, among which were chlorine, bromine, iodine, sulphur, phosphorus, phosphine, hydrochloric acid, methane, argon, etc., but in no case did these gases produce blackening, provided great care was taken to have them extremely dry. The behavior of argon was interesting. At pressures above five microns and below one micron, a glow occurs in the bulb, current flowing from one filament leg to the other through the gas. This so-called "Edison effect" caused the bulb to blacken rapidly. The small amount of argon which might exist in an ordinary lamp could not, however, produce such blackening.

This study led Dr. Langmuir to the conclusion that if the blackening of the bulbs of ordinary lamps was caused by imperfect vacuum, it must be due to water vapor. He devised new methods of producing extremely high vacua, improving the vacuum from a millionth to much less than a billionth of an atmosphere. Extra precautions were taken to remove all traces of water vapor and, to make sure that water vapor was not evolved by the bulb becoming hot, lamps were even run with the bulbs completely immersed in liquid air during their entire life.

The unexpected result of his work was that with all these precautions, the lamps were not materially better than the best lamps regularly made in the factory. There seemed to be no hope of improving the lamp by getting a better vacuum, the vacuum in the ordinary lamp being good enough. The investigations did show however, that, excepting water vapor, the presence of gas in small quantities in tungsten filament lamps did not seem to cause blackening and that the only one of the suggested causes of blackening which had not been investigated was the true evaporation of the filament. This he probably never would have discovered if he had not endeavored to find an explanation for the various phenomena found, rather than by trying to look for a definite object.

To test out the theory that true evaporation is the cause of blackening, Dr. Langmuir made many experiments to

THE INCANDESCENT LAMP

determine the rate of loss of weight of tungsten filaments operated at various temperatures. The actual results agreed remarkably well with the theoretical figures, which indicated that blackening of well-made tungsten filament lamps is caused by true evaporation of the filament.

Introduction of Gases at Atmospheric Pressure

It was possible that the presence of a chemically inert gas inside the bulb would reduce the rate of evaporation of the filament provided the phenomenon was simply one of evaporation. This is somewhat similar to the effect air pressure has on the boiling point of water. At sea level, water boils at 212 deg. F.; at high altitudes where the air pressure is less, the boiling temperature is less. Thus if a gas pressure were put in the lamp it might retard the evaporation of the filament, though it had usually been found that the presence of a considerable amount of gas caused an increase in the rate of disintegration of a heated metal. Dr. Langmuir had shown that low pressures of gases, except water vapor and argon, did not produce blackening of the bulb, and, therefore did not produce disintegration in the ordinary sense, and that hydrogen, nitrogen, argon and mercury vapor seemed chemically inert towards tungsten at high temperatures.

To test this out, a tungsten filament lamp was made which was filled with carefully dried and purified hydrogen at atmospheric pressure. The filament was run at the same temperature as that of vacuum lamps operating at one watt per candle. The loss of heat, due to its conduction away from the filament by the gas, was so great that 17 watts were required for each candle power (less than 0.6 lumens per watt) actually produced in this lamp. The heat is conducted away from the filament by its contact with the gas, on the same principle that causes the handle of a poker to become hot when the other end is put into a fire. Furthermore, the heated gas rises, circulating in the bulb and forming convection currents, thereby rapidly transferring the heat to the upper part of the bulb. This is why

THE INCANDESCENT LAMP

so much more electrical energy (watts) had to be put into the filament to maintain it at the same temperature as that obtainable in vacuum, where these heat losses do not occur.

This hydrogen filled lamp burned for more than 360 hours without showing any blackening of the bulb, but the loss of heat was so great, and so much more electrical energy was required to maintain the proper temperature, that it was impractical from a commercial standpoint. Subsequently it was found that while the heat conductivity of hydrogen is high compared with other gases, the amount of electrical energy required to operate the lamp was abnormally great, because at high temperatures the hydrogen molecules break up into their two atoms (as Dr. Langmuir had previously discovered), absorbing an added amount of electrical energy.

Experiments were then tried with tungsten filaments in mercury vapor at atmospheric pressure and the heat loss by convection was found to be extremely small in comparison with hydrogen, so small that the filament could be operated for about a minute at $21\frac{1}{2}$ lumens per watt. The experiments showed that the presence of mercury vapor very greatly retarded the rate of evaporation of the filament.

Nitrogen at atmospheric pressure was next tried and found to be entirely inert towards the high temperature tungsten filament. Comparatively so little heat was taken away from a large diameter filament operating close to its melting temperature that it could be operated for a moment at 22 lumens per watt. At the melting temperature of tungsten, it would theoretically give an efficiency of about 25 lumens per watt in vacuum. The rate of evaporation of tungsten at high temperature in nitrogen was also found to be less than in vacuum.

A slight increase in the temperature of a filament, which requires but a small increase in electrical energy (watts) will make a great increase in the amount of light it gives. This, however, is done at a sacrifice to the life of the lamp. The rate of evaporation of the filament at a

THE INCANDESCENT LAMP

given temperature having been found to be less in gas than in vacuum, the next thing to be determined was whether or not the filament could be operated in gas at a higher temperature (and so obtain more light for the same life) than possible in vacuum and yet not require more watts for the actual candle power obtained. In other words, was it possible that a gas-filled lamp, having the handicap of large heat losses by convection, could be made more efficient than a vacuum lamp not having this handicap, both lamps having the same life. A careful study was therefore undertaken of the laws of heat convection from filaments at high temperatures in various gases, since the knowledge on this subject was extremely meager.

Study of the Dissipation of Heat from Hot Wires

Dr. Langmuir had studied abroad in 1903-5 and had made some researches on the effect of highly heated platinum wires in dissociating steam, and other vapors and gases. He had become interested in the laws governing the dissipation of heat from hot wires, and when he returned to this country he continued this investigation, but had little opportunity to experiment until he entered the Research Laboratories of the General Electric Company. Some experiments he conducted at Pittsfield, in 1911 on electric heating devices broadened his knowledge.

Further experiments were then made to determine the laws of heat convection, by operating platinum wires in air, carbon dioxide, and hydrogen, and tungsten wires in hydrogen, nitrogen, mercury vapor and argon. He found that the heat loss varies with the temperature, according to a simple function of the heat conductivity of the gas, and also varies with the diameter of the wire according to a rather complicated formula. From this he derived an equation by which he could calculate the heat losses from a wire at any given temperature in various gases. This showed that the heat lost by convection increases (around high temperatures) rather slowly with increases in temperature in the case of nitrogen and mercury vapor, but increases very rapidly in the case of hydrogen. It also

THE INCANDESCENT LAMP

showed that the heat loss from very small wires, such as those of about a thousandth of an inch in diameter, was not very different from wires of several times this diameter. This was most unexpected; one would think that if the size and, therefore, surface of the wire were doubled, the rate at which heat was lost would be doubled, but this is not true.

Dr. Langmuir's explanation of this is that a wire or filament, in the case of a lamp, seems to hold a layer of hot gas, about a sixth of an inch in thickness, which adheres to it, the thickness of this gas film being independent (within certain limits) of the diameter of the filament. Halving the diameter of the filament, therefore, does not halve the thickness of the filament with its gas film. For example, a filament two-sixths of an inch in diameter would, with its gas film, have a diameter of four-sixths of an inch. A filament of one-sixth of an inch in diameter, 50 per cent less than that of the former, has a diameter of three-sixths of an inch with its gas film which is 25 per cent less than that of the former (four-sixths as compared with three-sixths). Hence the effective cooling surface of a thin filament is relatively greater than that of a thick filament. From this it will be seen that with small wires more heat is proportionally lost than with large wires.

The increase in temperature necessary, due to the presence of gas in the bulb at about atmospheric pressure, in order that a gas-filled lamp could operate at the same efficiency as a vacuum lamp, would, therefore, be very much greater with thin filaments than with thick ones. Thus in nitrogen, Dr. Langmuir estimated that a filament of 1.1 thousandths of an inch in diameter (the size of tungsten filament of a 25-watt, 110-volt vacuum lamp) would have to operate at about 2600 deg. C. to give nine lumens per watt, the present efficiency of the 25-watt vacuum lamp. The 25-watt vacuum lamp now operates at about 2050 deg. giving a life of a thousand hours, and if operated at 2600 deg. would last about half an hour. It will be seen, therefore, that the reduction in rate of evaporation (and consequent

THE INCANDESCENT LAMP

increase in life) due to the gas would have to be very great to overcome the handicap imposed by the gas in lamps having small diameter filaments.

On the other hand, a filament of 13 thousandths of an inch in diameter, which would be the size of the filament in a 1000-watt, 110-volt vacuum lamp, if such a lamp were made, would only have to operate in nitrogen at 2300 deg. as compared with 2200 deg. C. in vacuum for the same efficiency. A 1000-watt, vacuum lamp operated at 2200 deg. would give a thousand hours life and if operated at 2300 deg. would last about sixty hours. Thus with thick filament lamps the handicap of the gas should not be so great.

These calculations did not prove that the introduction of gas would produce a better lamp, but indicated that if it were possible at all, it could be done more easily by using large diameter filaments. There was nothing to indicate how great the reduction in evaporation would be, so that it would have to be found by experiment, but the calculations showed in what manner the experiments should be conducted.

Experimental Gas-filled Tungsten Filament Lamps

Dr. Langmuir made two sets of thick filament lamps, one set operating in nitrogen at atmospheric pressure and the other set in vacuum. In both sets the filaments were operated at the same efficiency in order that the life results could be compared. The nitrogen-filled lamps were failures.

This was very discouraging and probably to the ordinary experimenter would have ended the investigation. But Dr. Langmuir had built up a theory that the nitrogen-filled lamps should be better, his former experiments showing that the evaporation of the filaments in gas was less than in vacuum, although its extent had not been determined. It seemed as if the extent should be great enough to overcome the handicap of the extra heat losses due to the gas, provided thick filaments were used. This faith encouraged him to continue his research, but before

THE INCANDESCENT LAMP

trying the experiments again he carefully examined the lamps he had tested to see if he could find any clue that might show him the cause of their failure.

He noticed that the deposit of evaporated material from the filament was located at the upper part of the bulb where it was expected to be, having been carried there by

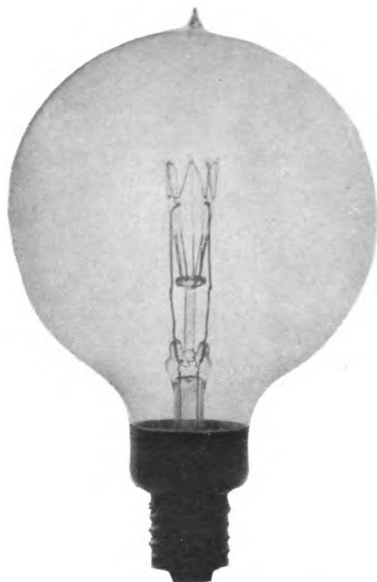

GAS-FILLED TUNGSTEN FILAMENT LAMP, 1913

This lamp, invented by Dr. Irving Langmuir, was twice as efficient in the larger sizes as the vacuum lamp. The bulb was filled with nitrogen gas at about atmospheric pressure. The filament was coiled.

the circulating currents of gas in the bulb, but the deposit was black instead of brown. He had found in previous experiments with nitrogen that the otherwise black deposit of tungsten was changed to brown, owing to the formation of tungsten nitride. It seemed strange that this had not

THE INCANDESCENT LAMP

happened in these lamps, so he concluded that there must have been some trace of water vapor in the nitrogen gas which was responsible, in spite of the extraordinary precautions he had taken to prevent its presence.

He then repeated the experiments, taking still greater precautions to eliminate any water vapor, and this time his experiments were successful. The filaments he used were relatively very large, two to four hundredths of an inch in diameter, requiring from 20 to 60 amperes of current. Such lamps for 110-volt circuits would consume from about 2000 to 6000 watts, and would be very large compared with the ordinary vacuum tungsten filament lamps of 25, 40 and 50 watts used in the home, and large even when compared with the biggest vacuum lamp then made for commercial lighting, which consumed 500 watts.

Dr. Langmuir then conceived the idea that the effect of a large filament might be obtained by properly coiling a small one. In designing such coiled filaments, it was evidently desirable to wind the filament on as large a mandrel as possible to obtain the advantage of the large diameter. It was also desirable to have the coils as close together as possible. Tungsten is a relatively soft material at the operating temperatures of these lamps. If too large a mandrel were used, the weight of the filament would pull out the helix very materially in a few hours, so that the heat lost by convection would be increased. This sagging of the wire might also allow the lower turns of the coil to touch each other and short circuit, so the spacing between turns of the coil must not be too small. Careful experiment showed that certain mandrel sizes and spacings gave the best results. He then was able to make a gas-filled lamp, taking a little less than ten amperes, and consuming 1000 watts on 110-volt circuits, which was twice as efficient as a vacuum lamp for the same life. Further experience made it possible to produce a 750-watt lamp and these lamps were put on the market late in 1913. Dr. Langmuir applied for a patent in April, 1913, which was granted in the same month of 1916.

THE INCANDESCENT LAMP

In order to distinguish the vacuum from the gas-filled lamp, the former is called a MAZDA B lamp and the latter a MAZDA C lamp. If these designating letters after the trade mark MAZDA had been desirable at the time the pressed filament lamp was being commercially made, the pressed filament lamp would have been known as a MAZDA A lamp.



DR. LANGMUIR AND MR. EDISON, 1922

When Mr. Edison visited the Research Laboratories at Schenectady in 1922, Dr. Langmuir showed him a 30,000-watt lamp he had made for experimental purposes. This is the largest lamp ever made, giving 100,000 candle power.

Exhaustion of Gas-filled Lamps

The moisture exhaustion problem is present in the gas filled lamp to as great, if not to a greater, degree than in the

THE INCANDESCENT LAMP

vacuum lamp. It is just as necessary to get rid of this moisture in the gas-filled lamp and it is more difficult because the blue glow of ionization which is such a great help in clearing up the moisture with phosphorus in the vacuum lamp does not appear in the gas-filled lamp. Other means, which are not so simple and easy as the clean up with phosphorus, must be used to get rid of the moisture. Washing out the moisture with dry gas is the most practical and is now used in regular factory practice. Several washings are necessary; dry air can be used for the first washings and dry nitrogen for the later ones.

High vacuum pumps are not necessary in exhausting gas-filled lamps because the washing out removes all the air and other gases and vapors without requiring a high vacuum at any time. The pumps used in this work have large capacity and produce a vacuum of about two-tenths of an inch (about 800 microns). When these lamps are sealed off they contain a sufficient amount of argon (with about 15 per cent of nitrogen) to make the pressure inside the lamp equal to atmospheric pressure when the lamp is burning.

Although phosphorus does not clean up the moisture in a gas-filled lamp as it does in a vacuum lamp, it has a good effect in taking care of the moisture which is left after the lamp is sealed off. It is put on the filament in gas-filled lamps as in vacuum lamps. Carbon and carbon compounds are also used, these and phosphorus possibly having a continuing action during the life of the lamps in taking care of water vapor and oxygen. The action of carbon, however, will cease when all of the carbon has been removed from the filament.

Previous Attempts to Make Gas-filled Lamps

Mention has been made that several Russian scientists had attempted fifty years ago to make lamps having a graphite burner operating in nitrogen gas. In 1878-9, Sawyer had tried the same thing, as has been stated, and failed. Even Edison had tried the use of nitrogen in the experimental lamps he made in the early eighties, after he had invented his practical vacuum lamp, and he also failed.

THE INCANDESCENT LAMP

Edison knew that nitrogen would cool the filament, and tried to compensate for this by using a filament of smaller cross-section. He did not know why he failed, but found out that his gas-filled lamp lasted only one twentieth as long as a vacuum lamp at the same efficiency. Even after Dr. Langmuir's success, the Research Laboratory of the General Electric Company was unable to produce a gas-filled carbon lamp as good as a vacuum carbon lamp.

The "Novak" lamp, previously mentioned, which was made for a while in 1892, and which contained bromine gas at a pressure of about two one-thousandth parts of the atmosphere, cannot be construed as a gas-filled lamp. The Courts decided it was a vacuum lamp and therefore infringed upon Edison's basic vacuum lamp patent. Gettered lamps as originally made, in which a slight trace of gas was generated as the lamps burned, cannot be said to be gas-filled lamps either as the vacuum in such gettered lamps is at least one-thousandth part of atmospheric pressure, whereas the gas in the lamp invented by Dr. Langmuir is at about atmospheric pressure.

In this connection Dr. Langmuir found that there was no material advantage in having the gas pressure in the bulb much greater than that of the atmosphere. Even if it were desirable, there might be danger of the lamp's exploding. The gas is put in the bulb at slightly less than atmospheric pressure, so that when the lamp is lighted and becomes heated, the gas expands to a pressure about equal to that of the atmosphere.

Commercial Developments of the Gas-filled Lamp

The first commercial lamps, those of 1000 and 750 watts for 110-volt circuits, were made with round bulbs. The circulating currents of gas in the bulb in rising made the base quite hot, the heat being conducted to the socket holding the lamp. In order to lower the temperature of the base and socket, the bulb shape was changed by putting a tubular glass neck on the upper part of the bulb, a mica disk keeping the gas from circulating in the neck. The simpler

THE INCANDESCENT LAMP

shaped straight sided bulb was adopted soon after, which later was changed to pear shape.

As the art of making MAZDA C lamps progressed, it became possible to make smaller sizes. In July, 1924, 500- and 400-watt lamps for 110-volt circuits were developed, these lamps, on account of their smaller diameter filaments, not being quite as efficient as the larger sizes. They were, however, considerably more efficient than the same size of MAZDA B lamps, which then disappeared from the market.

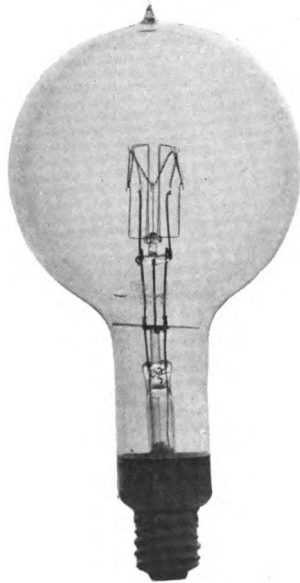

MAZDA C LAMP, JANUARY, 1914

A glass neck was put on the bulb, a mica disk preventing the circulating hot gas from reaching the base.

Series MAZDA C lamps were also made which displaced the vacuum lamps formerly used. These (as well as the former vacuum lamps) were more efficient with the 6.6-ampere filament in the ordinary sizes used, so the 6.6-ampere circuit for street lighting became the standard.

THE INCANDESCENT LAMP

Lamps for 220-volt circuits were developed but, of course, could not be made in as small a size as those for 110 volts, as the 220-volt filament is smaller in diameter than that for 110 volts for a given wattage. Concentrated filament lamps for projection service were also developed for such uses as floodlighting, motion picture projection, etc.

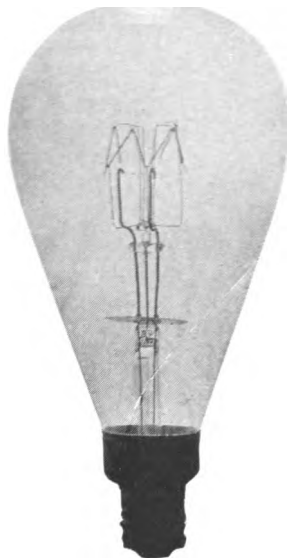

MAZDA C LAMP, JULY, 1914

Straight sided bulb used, a mica disk deflecting the circulating hot gas away from the base.

The efficiency of the MAZDA C lamp is so high and the simplicity and convenience of the incandescent lamp is so great, that the carbon arc lamp was gradually displaced and has now practically disappeared from use. The only other forms of electric illuminants now in use are the magnetite

THE INCANDESCENT LAMP

arc lamp used in street lighting, and the Cooper-Hewitt mercury vapor arc, often used in photography. The magnetite arc gives a brilliantly luminous white light. The mercury arc is valuable in photography on account of the high actinic value of its light, to which the photographic negative is particularly sensitive.

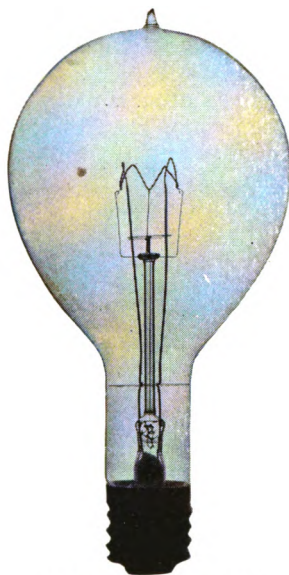

MAZDA C LAMP, 1915
Pear shaped bulb about as now used.

Still lower wattage MAZDA C lamps for 110-volt circuits were developed, the 200- and 300-watt lamps being put on the market in October, 1914. Argon gas with a small amount of nitrogen was and is now used on account of its lower heat conductivity, with consequently less cooling of the filament. The lamps are therefore more efficient

THE INCANDESCENT LAMP

and it is possible to produce lower wattage MAZDA C lamps which are more efficient than MAZDA B lamps of this wattage and voltage. While Dr. Langmuir had found that pure argon in a lamp is a conductor of electricity, so that current would arc across from one end of the filament to the other, the lamp thus short circuiting, it was also found that such conditions were eliminated by adding about fifteen per cent of nitrogen gas to the argon. Argon is one of the constituents of the air, but is present only in small quantities, about one-half of one per cent. The necessity for developing a process to obtain argon in reasonable quantities caused some time to elapse before the gas became available in sufficient amounts to make an argon-filled lamp commercial. This gas has made it practicable to make lamps consuming a current as low as half an ampere. On 110-volt circuits the 50-watt lamp is therefore available, the minimum wattage, of course, decreasing as the voltage decreases. Thus on 60-volt circuits, 25-watt lamps can be had; 15 watts on 30 volts; etc. This limit of half an ampere does not quite apply on very low voltages, as in such cases the filament is much shorter, and therefore the amount of heat conducted away by the leading-in wires becomes proportionally greater, so that the minimum size increases with very low voltage lamps.

On 6-8-volt automobile lighting circuits the 21 candle-power MAZDA C headlight lamp is now standard, it being a legal requirement to use this lamp in certain states. The lamp consumes about $2\frac{1}{2}$ amperes.

It is uneconomical to use MAZDA C lamps of smaller sizes than those given above, because, while it is possible to make them, their efficiency would be no better than that of a vacuum lamp for the same life. They can be made to give a higher efficiency, but their life would be correspondingly shortened. As the art progresses it may be possible some day to make still smaller MAZDA C lamps which would be more efficient than the same wattage size of MAZDA B lamps and yet have the same life.

CHAPTER FIVE

LEADING-IN WIRE DEVELOPMENTS

The electric current which heats the filament inside the bulb to incandescence is carried to the filament by two wires which pass through the glass chamber. These wires must make an air-tight joint with the glass in order to preserve the vacuum and, in a gas-filled lamp, to prevent either the air entering or the gas leaving the bulb.

In the beginning, platinum was the only material known which would answer the purpose and it was used for many years. It was comparatively cheap in the early days, about six dollars an ounce, but the cost gradually increased. As the cost increased the amount used was reduced.

Substitutes for platinum have been sought almost from the beginning, and some lamp manufacturers quite early used nickel-steel wire with fair success. This nickel-steel alloy can be made to have the same expansion as glass, but it does not stick to the glass and is never one hundred per cent efficient. The seal between the leading-in wires and the glass is made at high temperature when the glass is soft and, as it cools down, the wire and glass must stick together as they contract to the lower temperature. This is a greater range in temperature than that between the lighted and unlighted lamp, in which the wire and glass must also stick together to make an air tight seal.

The leading-in wires present other problems beside making a tight joint with the glass. They must be good conductors of electricity, which nickel-steel is not. So in many lamps, copper wires were and are now welded to the wire imbedded in the glass. At the present time pieces of copper wire are, in all lamps, welded to these short wires imbedded in the glass, passing outward to connect with the terminals of the base to which they are soldered. In vacuum lamps, copper wires are used going inward to connect with

THE INCANDESCENT LAMP

the filament, it having been found that copper is the best material for filament connection. It is always oxidized in making the lamp, because the oxide acts as a beneficial "getter" in vacuum lamps. In gas-filled lamps, nickel wire is much better than copper for filament connections. Copper oxide has a bad effect, while clean nickel is the best material known for the purpose.

Originally the seal between the leading-in wires and the glass was made by fusing a piece of small glass tubing around each wire, two such wires with their glass "petti-

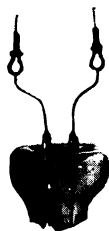

ORIGINAL STEM SEAL, 1880

This shows how current was passed through the glass bulb to the filament inside, in the first lamps commercially used in 1880.

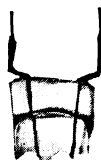

FLAT STEM SEAL, 1881

This greatly simplified the glass work of the stem. This construction has been used ever since.

coats" being inserted in a stem tube. The end of the stem tube which went inside the bulb was closed by fusing it around the glass petticoats on the wires. In the latter part of 1880 the glass work of the stem seal was greatly simplified. The petticoats of glass were omitted, the end of the stem tube being flattened together about the two wires. This method has been used ever since.

Clamps

The connections between the leading-in wires and the filament have been a problem from the beginning. At first a little screw clamp was used which held the enlarged end of the carbon filament in its jaws, the other end of the clamp being fastened to the platinum leading-in wire. At first these clamps were made of platinum and later of nickel.

THE INCANDESCENT LAMP

These screw clamps were used until early in 1881, when the copperplated connection came into use. In this arrangement a piece of copper wire was welded to the platinum wire, the latter being sealed in the glass. The other end of the copper wire was flattened quite thin, bent double, folded about the enlarged end of the filament and the connection made good by copperplating. As long as this connection

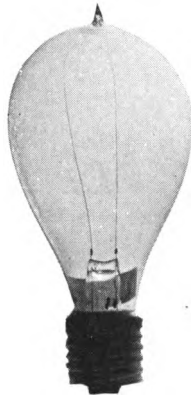

EDISON LAMP, 1889

The length of the seal was reduced so that less platinum was necessary for the leading-in wires.

was used the filaments were made with enlarged ends so that the part of the filament which was in contact with the copper would not become hot enough to melt the copper or vaporize it.

In 1886, carbon paste joints were introduced. At first the carbon paste was made of india ink and fine graphite, but soon a better paste was made of two kinds of graphite, one of which contained a considerable amount of clay. This graphite mixture was mixed with a binder composed of a solution of sugar and gum arabic. These paste joints were baked in an oven to about 400 deg. F. to partly car-

THE INCANDESCENT LAMP

bonize the binder, otherwise in damp weather some of the joints would absorb moisture and become loose before they were sealed in the bulb.

For large sized filaments a special paste was used, consisting of coarse graphite, soft coal and coal tar pitch with sugar and gum arabic binder. After these joints had been baked, each was painted with a little red phosphorus and was heated red hot on a fine gas jet. The heating decomposed the hydrocarbons, drove out a lot

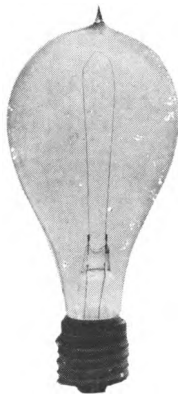

EDISON LAMP, 1890

The amount of platinum wire in the seal was further reduced by imbedding the welds between the copper and platinum wires in the seal.

of gas and smoke, and left a hard piece of coke for the joint which gave out very little gas during exhaustion.

At the present time a material called "aquadag" is used for the paste joint in the few carbon lamps made. Aquadag is an extremely fine graphite powder mixed with water. When dry it becomes pure carbon and yields practically no gas in exhaustion. This enables the exhaustion of the present carbon filament lamps without lighting up, for most of the gas which appeared in the previous carbon filament lamps during exhaustion came from the paste joints.

THE INCANDESCENT LAMP

When the pressed tungsten filament came into use, the connections between the filament and the leading-in wires were made by fusing the two together with an electric arc. This was done in a reducing gas atmosphere to prevent burning the filament. This practice was continued as long as pressed filaments were used.

At first the connections for drawn wire filaments were made by forming short tubes in the ends of the leading-in wires, inserting the ends of the filaments in the tubes and flattening and crimping the tubes on the filament ends. This made a good connection, but the construction was expensive. It was simplified by what is called the hook connection. The end of the leading-in wire was flattened and folded over on itself, forming a hook. The end of the filament was placed inside the hook and the hook pressed hard on the filament, which imbedded the hard filament wire in the softer leading-in wire. This also made a very good connection and is in general use today. Some large size filaments are electric spot welded, and the very largest sizes are electric arc welded, to the leading-in wires.

Substitutes for Platinum Leading-in Wires

The first substitute wire commercially used on a large scale was that invented by Byron E. Eldred, which is covered by a patent applied for in October, 1911, and granted in December, 1913. This wire consisted of a nickel-iron alloy core which was dipped in an acid copper-sulphate bath to give it a slight coating of copper, then silver plated and further covered by a platinum sheath. This composite wire was so proportioned in its parts that it was designed to have a slightly lesser coefficient of expansion than glass, so that in cooling down from the high temperature at which the seal is made to the temperature at which this part of the lamp operates, a pinch effect of the glass on the wire was obtained. It was commercially used from 1911 until the early part of 1913.

The use of the non-oxidizable platinum outer sheath was deemed necessary, as glass would not "wet," that is, make a hermetic seal with, or stick to, a bare wire of any

THE INCANDESCENT LAMP

base metal or of nickel-iron or other alloy if the wire were made large enough to be used as a leading-in wire. The intermediate copper and silver was for the purpose of making a tight union between the nickel-iron core and outside platinum sheath which could not be directly made.

Dr. Colin G. Fink, of the Research Laboratories of the General Electric Company, invented an improved wire which was put into commercial use in 1913, superseding Eldred's wire. Fink's wire consisted simply of a nickel-iron



ASSEMBLY OF MATERIALS OF DUMET WIRE.

This leading-in wire, which took the place of platinum in 1913, consists of a nickel-iron core with a copper sheath. After brazing the two together and drawing to the proper diameter, the wire is coated with borax.

core, dipped in acid copper-sulphate to give it the thin copper coating, and inserted in a brass sheath in order that the outer copper sheath could be readily brazed to the nickel-iron core. This wire has an expansion coefficient that was practically the same as that of glass. The sheath is about 20 per cent by volume of the wire, the proportions of the core being about 45 per cent nickel and 55 per cent iron. This wire is even better than platinum itself and

THE INCANDESCENT LAMP

its use has resulted in a much smaller percentage of leaky lamps. While copper oxidizes readily, it was found that if the pinched seal is heated somewhat longer than formerly, the glass absorbs the oxide and makes a very tight union. This wire is called "dumet" wire. Dr. Fink applied for a patent in June, 1912, which was granted in June, 1924.

The sealing in of dumet wire was improved by W. L. Van Keuren, of the General Electric Company, by coating the wire with borax. Van Keuren applied for a patent on

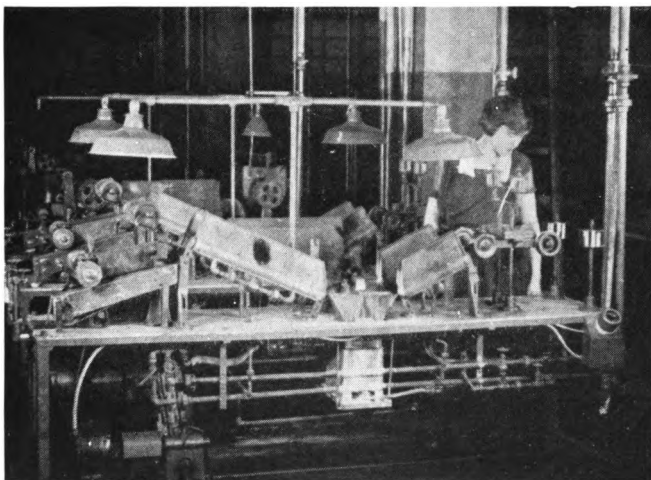

COATING DUMET WIRE WITH BORAX

this in December, 1913, which was granted in June, 1918. The dumet wire is heated to slightly oxidize it, and is then dipped in a solution of borax which in drying and heating forms a copper borate with the oxide and makes a ready seal with the glass. Under the conditions which exist in sealing the wire in the very hot glass, the copper borate is largely absorbed in the glass and the union between

THE INCANDESCENT LAMP

wire and glass becomes very tight. The wire makes a tighter joint with glass than platinum, and is a better material for the purpose. It is also relatively inexpensive to make compared with platinum, which has risen steadily in cost and is now well over one hundred dollars an ounce.

About twenty years ago, Geist invented a leading-in wire composed entirely of copper. He used a copper wire about sixteen thousandths of an inch in diameter and flattened it at the point at which it was sealed in the glass, so that it was very thin. He also made a round hole in the center of this flat part. For some reason he could not make these seals consistently effective, but he did succeed with a large majority of them. Recently this invention has been further developed and when the flattened parts are made much thinner, about one and one-half thousandths of an inch, cross section, the wires make perfect seals. An automatic machine has been developed and many thousands of trial lamps have been manufactured using all copper leading-in wires of this type. The copper unites so firmly with the glass that even though it shrinks more than glass, the shrinkage of these very thin parts does not pull them away from the glass. No hole is now made in the thin section of copper.

In cases where the requirements to be met by the lamps necessitate the use of a specially hard glass in the seal, which will stand high temperatures without softening, large tungsten wires are used for the leading-in wires. Since the temperature expansion coefficient of such hard glass is about the same as that of tungsten, the combination of the two results in a tight seal.

CHAPTER SIX

GLASS CONSTRUCTION

When Edison began experimenting on electric lamps he, like all other experimenters, made the glass chamber in two parts which were separably fitted together. This enabled him to renew a filament easily. Later when he realized that he must use a thin high resistance filament, he also realized that the very high vacuum, which was necessary to preserve this thin filament, could not be maintained in a two-piece glass envelope, as the joint was often subject to leaks. He then made a very bold decision. He abandoned the two separable piece construction and with it the ability to replace a broken filament. He fused the two parts of the bulb inseparably together, saying, "I will make the lamps so long lived and so cheap that they can be thrown away when the filament burns out."

This one-piece glass chamber was one of the elements of the combination which he patented and which the courts decided covered all successful incandescent lamps. This glass chamber consists of two principal parts: the bulb, and the inside part, or stem, which carries the leading-in wires and filament.

Bulb Making

At first the bulbs were made by hand from one-inch tubing. Shortly after the lamp factory was started, bulbs were made at the Corning Glass Works, being hand made and free blown from glass taken directly from the furnaces. These free blown bulbs were used by the Edison Lamp Works for about twelve years, although other lamp manufacturers adopted moulded bulbs much earlier. The hand made moulded bulbs were uniform in size and shape, while the free blown bulbs varied a great deal and had to be gauged and sized into groups of similar dimensions.

THE INCANDESCENT LAMP

The hand made moulded bulbs were used for about twenty-five years before machines were developed to make them. Bulbs are now made by a ponderous automatic machine which takes the molten glass from the

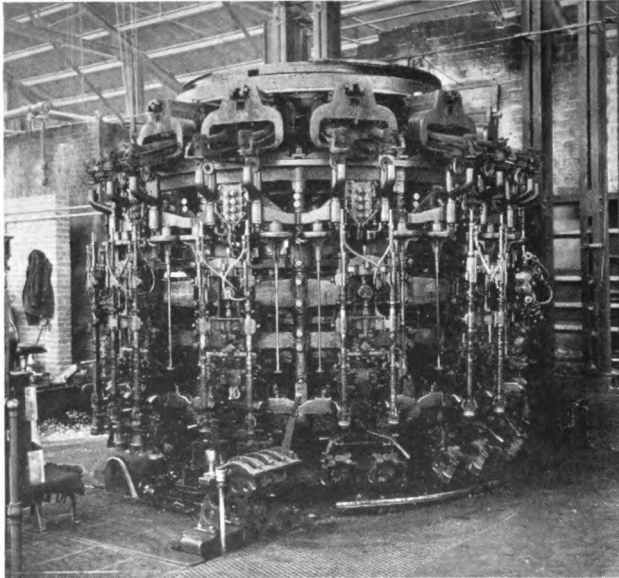

BULB BLOWING MACHINE.

This ponderous machine turns out 50,000 bulbs per working day of 24 hours and greatly reduces their cost.

furnace in measured amounts, shapes it, blows it in a mould and delivers the moulded glass bulb to another machine which removes the superfluous glass from the neck of the bulb. The completed bulbs are then automatically delivered to a conveyor which carries them through an annealing furnace to the inspectors where they are handled for the first time. Each machine has twenty-four arms on

THE INCANDESCENT LAMP

which the bulbs are made, the machine making 70,000 bulbs per working day of 24 hours.

Automobile headlight bulbs and bulbs for most miniature lamps are made from tubing in automatic machines which blow them in moulds. A very few bulbs for special types of miniature lamps are still made by hand from tubing held in a horizontal lathe.

Stem Making

The inside part or stem is now and always has been made from tubing. Stems have passed through several



EARLY HAND BLOWN STEM, 1881

An enlargement was blown on a piece of glass tubing to which the neck of the bulb was sealed.



FLARED STEM, 1893

This was much simpler to make, less glass was used and the seal with the bulb was less liable to crack.

changes of form and methods of manufacture. In the very early stems, an enlargement was blown at about the center of a piece of tubing, the enlargement serving as a foundation to which the neck of the bulb was fused. The tubing was left long enough to be used as a holder while the stem was being sealed to the neck of the bulb. After this sealing-in operation, the extra length of tubing was cut off and thrown away. Later the enlargement on the stem tubing was omitted, the stem consisting of a straight piece of tubing with the leading-in wires sealed in one end. The tubing was still made long enough to hold the stem while it was being sealed in the bulb, the extra length then being cut off and thrown away.

THE INCANDESCENT LAMP

In 1893, the short stem with the flared end, which had been developed in the Thomson-Houston factory, was adopted. No glass was cut off and wasted in this stem and it made a seal which was less liable to crack than the older forms.

With this stem, as with all previous stems, the neck of the bulb was cut off the desired length and the stem sealed to the rim on the end of the neck of the bulb. Later this was changed, the long neck of the bulb was not cut off, the flared stem was inserted well inside the neck and the excess neck cut off by the sealing-in fires at the exact point where the flare joined the bulb. This was a great improvement. The seals had less glass in them and so were less liable to crack, and did not have to be annealed as was the case with the previous ones. The long bulb neck also kept the water vapor, formed by the combustion of the gas, from getting inside the bulb and so made the exhaustion of the lamps easier.

Stem Making Machines

All stems were made by hand until 1901, when J. W. Howell, aided by W. R. Burrows, made a successful stem making machine which is essentially the same as the present day machine. It was a four-head vertical machine which enabled unskilled labor to make two or three times as many stems per day as a skilled operator could by hand.

The flared stem tube was inserted in the heads, the two leading-in wires placed inside the tube, and the anchor wire (of the carbon lamp) put in a holder which held it in position so that its end was inside the tube. These were heated in three positions while the work rotated, the hot end of the tube being squeezed into a flat mass, in the third position.

Flaring the Stem Tube

A number of different machines have been made for flaring the end of the stem tube. At first the pieces of glass tubing were placed in chucks by hand, the chucks rotating the tubing in the gas fires and the flare being

THE INCANDESCENT LAMP

formed by a hand tool. Later entirely automatic machines were made which placed the tubes in the chucks, formed the flares and delivered the flared tubes to the stem making machines.

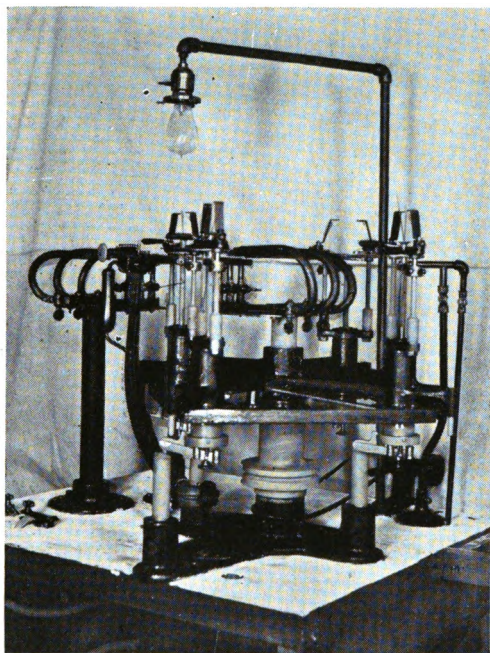

STEM MAKING MACHINE, 1901

Stems were made by hand until this machine was developed by J. W. Howell, aided by W. R. Burrows. It enabled unskilled labor to make more than twice as many stems as skilled labor could previously produce by hand.

Other automatic machines have been developed which make the flares on the ends of long tubes, the gas fires cutting off the desired length of flared stem tube. This

THE INCANDESCENT LAMP

method is considered the best because the tubing is cut by the fires while it is soft, whereby cracked and irregular edges are eliminated.

Tubulating

The first glass working tool was the "bulb punch," developed by William Holzer, of the Edison Lamp Works,

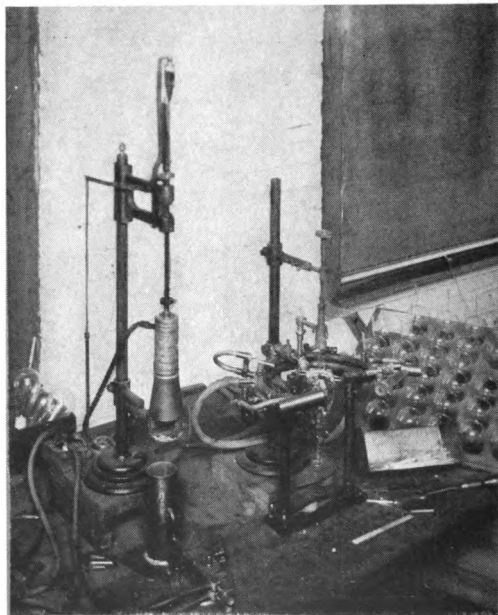

TUBULATING MACHINE, 1903

This machine was developed by W. R. Burrows. On the left, a hole was blown in the bulb by air pressure while the glass was softened by a gas flame. On the right, the exhaust tube was welded to the hole in the bulb.

early in 1883. This tool punched a tit in the round end of the bulb, the glass at this point being softened by a gas flame. The protruding glass of the tit was

THE INCANDESCENT LAMP

afterward cut off, leaving a hole where the exhaust tube was later sealed on to the bulb.

About 1903, William R. Burrows developed a tubulating machine. A fine pointed gas flame was allowed to play on the rounded end of the bulb, a slight air pressure being

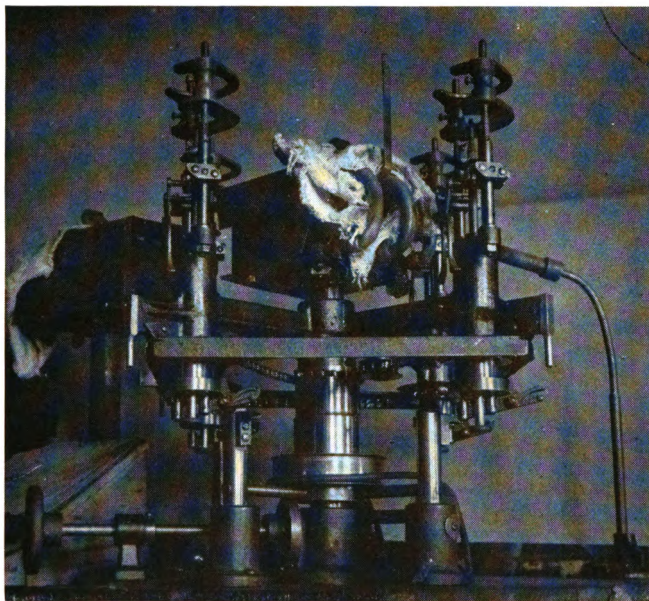

SEALING-IN MACHINE, 1896

This was developed by J. W. Howell and was the first of the modern machines. It is essentially the same as those now used and enabled the production per operator to be doubled.

put in the bulb. As the glass became softened, the air pressure blew a hole through the softened glass, blowing the flame away from the glass and so making the hole of uniform size. The exhaust tube was then welded to this hole. This machine remained in use about twenty

THE INCANDESCENT LAMP

years, or as long as bulbs were tubulated on the round end, and until the invention of the Mitchell and White method of tubulating the stem seal, which is described later.

Sealing-in Machines

The first glass working machine was a sealing-in machine, called the "Dufunny" and made by Edison about 1889, to seal the stem in the bulb. This was a single-head machine which simply held the bulb and stem in their proper relative positions while the two parts were sealed together. The machine held the work in a horizontal position, which is the natural position in hand working. While the machine enabled unskilled operators to perform the sealing-in operation, it did not increase the number an operator could produce in a day. The work rotated while it was being sealed in.

The first of the modern glass working machines was the four-head vertical sealing-in machine, made by John W. Howell in 1896, and which was essentially the same as the sealing-in machine of the present day. The work rotated and was heated in three positions, increasing the speed of operation very much. With this machine an unskilled operator could complete 600 lamps a day, which was more than twice as much as could be done before. These machines were made just in time to enable the factory to take care of a large increase in production without increasing floor space.

"Tipless" Construction

The tip of glass left on the round end of the bulb has always been recognized as an objectionable feature and many efforts have been made to get rid of it by tubulating the glass chamber in a position which would enable the tip to be covered by the base of the lamp, making a so-called "tipless" lamp. Many lamps have been made in previous years which were tubulated in the stem or at the seal of the bulb and stem, but the methods by which they were made were expensive and slow.

THE INCANDESCENT LAMP

One tipless method of construction was to weld a tube on the rounded end of the lamp bulb as was done in making the standard tipped lamp, and weld the glass stem holding the filament to the bulb. After this weld had been made a fine pointed flame was allowed to heat the glass at the seal where the stem is welded to the bulb. When the glass became soft, air was blown into the tube on the bulb

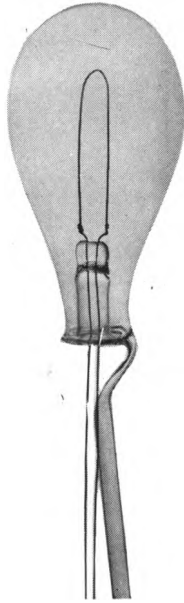

TUBULATED SEAL

By welding a curved exhaust tube to the seal, the tip on the sealed exhaust tube would be covered by the base, making a "tipless" lamp. The construction was too expensive for the general product.

and blew a hole through this soft glass part of the flare. A piece of curved glass tubing was then welded to this hole for the subsequent purpose of exhausting the air from the lamp. The tube on the bulb was then melted off and the hole closed up by allowing the soft glass to flow

THE INCANDESCENT LAMP

together, so that the bulb looked the same as before. The air was then pumped out through the curved exhaust tube, which, when sealed off, was covered by the base.

Another method was to make a nick in the edge of the flare of the glass stem so that when the stem was sealed in the bulb this nick left a hole in the edge of the seal. The curved exhaust tube was then welded to this hole in the flare. This did away with the necessity of welding the glass tube on the bulb of the lamp and later removing it.

Meridian Lamps

H. D. Burnett and S. E. Doane, of the General Electric Company, obtained a patent in 1894 for a tipless construction which, however, was not commercially used until about twelve years later, and then used only on a special type of lamp called the Meridian lamp, designed for decorative purposes to compete with the Nernst lamp. It was possible to obtain a higher price on the Meridian lamp, as compared with the standard line of incandescent lamps, which warranted the expense of making it tipless.

A machine was developed by Mark H. Branin, of the General Electric Company, for which he obtained a patent in 1906, to reduce the amount of handwork otherwise necessary in making the Meridian lamp. Inside the stem tube, in which the leading-in wires were later imbedded, a smaller diameter tube was placed through which the lamp was later exhausted. The end of the exhaust tube toward the inside of the lamp was flared and rested on a mandrel which projected into the exhaust tube.

The stem tube with the leading-in wires and exhaust tube were then heated at the end near the mandrel and when the glass was soft the parts were pinched together by a pair of pincers, which had a hole in the middle. This pinched the two glass tubes together so that a pair of glass "ears" were formed in which the leading-in wires were imbedded. The mandrel and hole in the pincers prevented the exhaust tube from collapsing.

THE INCANDESCENT LAMP

This process had many difficulties and caused a large amount of spoilage. The operator had to watch the conditions existing in the machine very closely. If the mandrel supporting and holding the exhaust tube open during the pinching process in making the seal became heated too much the glass would stick to it and be drawn out of shape when the stem was removed. If the mandrel was

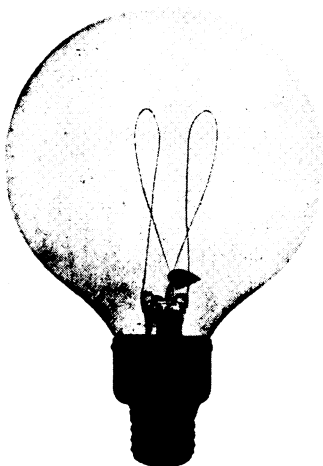

MERIDIAN LAMP, 1906

The exhaust tube was placed inside the stem tube, the two sealed together at the end. The leading-in wires were imbedded in glass protuberances made while the two were sealed together.

too cool it was apt to cause cracks in the glass, so that a considerable percentage of the product was spoiled. With the advent of the more efficient tungsten lamp the popularity of the Meridian lamp soon waned, its manufacture being stopped in 1910.

THE INCANDESCENT LAMP

Jaeger Tipless Lamp

In 1903, Herman J. Jaeger obtained a patent on a tipless construction which consisted of an "L" shaped exhaust tube sealed to the inside of the stem tube away from the pinched seal. After the stem had been made in the usual way, this "L" shaped exhaust tube was inserted in the stem tube and a fine pointed flame heated a spot on the side of the latter. The bent portion of the exhaust tube was then welded to this heated spot in the stem tube and by blowing through the exhaust tube a hole was made through the stem tube. Thus the exhaust tube, when sealed off,



JAEGER TUBULATED STEM

An "L" shaped exhaust tube was sealed to the inside of the stem tube away from the pinched seal.

was covered by the base, making a tipless lamp. This lamp was marketed for a number of years by the Tipless Lamp Company.

The Stemless Butt Seal

Low volt miniature lamps used as indicators in telephone switchboards have largely been made tipless since about 1898. In 1913, this construction was applied to flashlight lamps and, in 1915, to side and rear automobile lamps. These lamps have no glass stem to support the short filament, it being supported entirely by the two leading-in wires held rigidly together by a globule of glass. The leading-in wires, with the filament, are put inside the bulb, the wires bent over the edge of the neck of the bulb (which is of small diameter) and the flared end of a glass exhaust tube welded to the neck of the bulb, the leading-in wires being imbedded in the weld. This method of con-

THE INCANDESCENT LAMP

struction was practicable only with the stemless filament supported by the leading-in wires. The standard lighting lamps for 110-volt service require an additional filament support that is too heavy for the leading-in wires to carry.

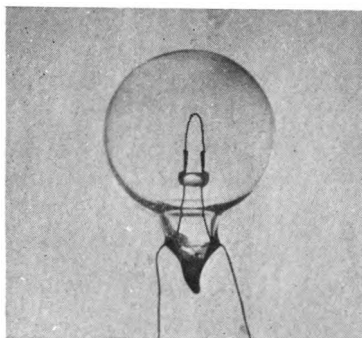

STEMLESS BUTT SEAL

This construction has been in use for several years on miniature lamps, producing a tipless lamp.

Mitchell and White Tipless Construction

L. E. Mitchell and A. J. White, of the General Electric Company, invented a method of tubulating the stem seal which made a great improvement in lamp construction. Their method eliminated tubulating as a separate operation, thus reducing the cost of lamp making and eliminating the exposed tip on the lamp. All lamps for standard lighting service are now so made.

In this method the exhaust tube is placed inside the stem tube in the stem making machine. The inner ends of the two tubes are sealed together, closing both tubes, making a mass of glass in which the leading-in wires are imbedded. While this mass of glass is still soft, air is blown in the outside end of the exhaust tube, the air pressure blowing a hole through the soft glass at this soft mass.

THE INCANDESCENT LAMP

Through this hole the exhaust tube communicates with the inside of the bulb.

Thus the tubulation of the lamp is done on the stem making machine. When the lamp has been exhausted and, in the case of gas-filled lamps, the gas has been allowed



MITCHELL & WHITE TIPLESS CONSTRUCTION

The exhaust tube is put inside the stem tube with the leading-in wires, the end fused and pinched together. While the seal is still soft, air is blown through the exhaust tube making an opening at the seal. All standard lamps are now made this way.

to flow in, the exhaust tube is sealed off close to the lamp so that the tip is completely concealed by the base.

Frosting

The light from a clear bulb incandescent lamp is exceedingly dazzling on account of the high brilliancy of the filament. In a carbon filament lamp this brilliancy is about a hundred times that of the ordinary candle and in a tungsten filament lamp from 200 to 2500 times. Thus while clear bulb lamps should always be shaded, in many

THE INCANDESCENT LAMP

cases the bare lamp must be used for various reasons. Under these circumstances "frosted" lamps have been occasionally used in place of clear ones, since the brilliancy is reduced about a hundred fold by frosting. Originally, the frosting consisted either of acid etching or of a coat of mineral paint sprayed onto the surface of the bulb.

The higher cost and slight loss of light due to absorption by the frosting prevented the use of frosted lamps in many places where they should have been used. These

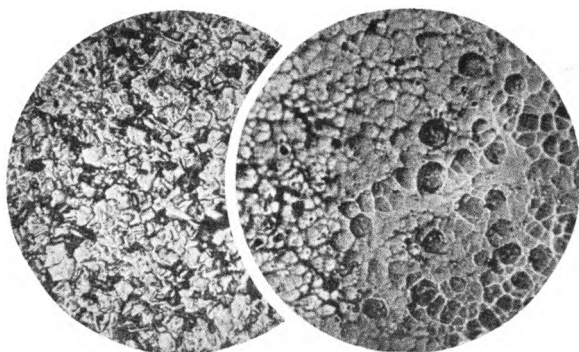

Before Treating

After Treating

PHOTOMICROGRAPHS OF INSIDE FROSTING

If a lamp bulb is acid frosted on the inside, the bulb becomes fragile.

Marvin Pipkin restored the strength by a chemical treatment which rounded out the minute cracks made by the acid frosting. Inside frosting absorbs less than two per cent of the light, which is about one-third that absorbed by outside frosting.

objections, and the limitations they imposed on the frosted type of lamp, have been eliminated by a recent invention of Marvin Pipkin of the General Electric Company, which not only cuts the loss by absorption to a third of its former value, but, since it is practical for quantity production, has reduced the price of the lamps.

The advantages of frosting an incandescent lamp on the inside of the bulb have been realized for many years, but until recently no satisfactory method has been devised.

THE INCANDESCENT LAMP

It is obvious that a lamp having a smooth outer surface, will be more apt to stay clean than one having a roughened outer surface.

The absorption due to frosting is considerably less with inside than with outside frosting. If the frosting is on the outside, the light from the filament goes through the glass wall of the bulb to the irregular frosted surface where some of it is diffused. The remainder of the light is reflected back through the glass to the opposite wall of the bulb. This process is repeated again and again until most of the light gets out. Some light, however, is absorbed each time

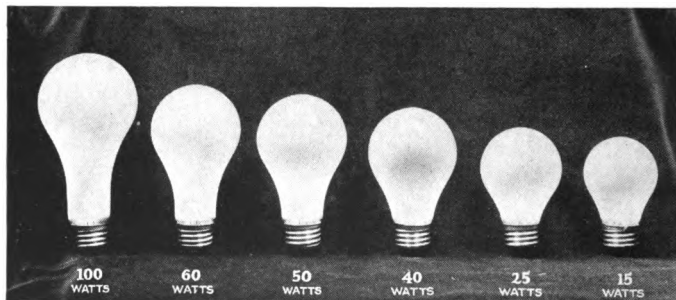

STANDARD LAMPS

These are the six standard lamps of the new line which replaced the forty-five different types and sizes for standard lighting service previously used. The lamps have a new shaped bulb which is frosted on the inside.

it passes through the glass. If the frosting is on the inside surface of the bulb, the cross reflections from the frosting do not have to pass through the glass walls of the bulb each time, which may be an explanation for its lesser absorption.

The ordinary acid frosting on the inside of the bulb weakens the bulb and renders such lamps subject to breakage. It etches the bulb and causes minute cracks or splits to appear just below the surface of the glass. When the bulb is evacuated, the inside surface of the glass is under tension from the air pressure on the outside surface, and the cracks

THE INCANDESCENT LAMP

on the inside surface of the bulb cause it to break easily just as a steel truss will break with a crack at the bottom and pressure on top. If the frosting is on the outside, the glass is not materially weakened, as then the etched glass surface is on the outside under compression, the compressive strength of a piece of glass being greater than its tensile strength.

It is a well known fact that if a round hole is drilled at the end of a crack or split in a steel truss, it will withstand a greater weight. Mr. Pipkin discovered that if an inside frosted lamp is subjected to the proper treatment, the entire area of the inside surface will become etched in such a manner as to round out the bottoms of these cracks. The effect of this action is to restore the strength of the bulb to its former value. This he accomplished by chemically treating the inside of the bulb after it had been acid etched.

The new inside frosted lamps were first put on the market in 1925 with a new shape of bulb which is considered more pleasing in appearance and which is expected to replace many of the different shaped bulbs used in the past. This new standard line of six lamps is intended to replace approximately forty-five different lamps heretofore supplied.

The Unit Machine

The process of making a lamp consists of a succession of steps, each of which is an independent operation. A glass tube is made into a stem, a glass rod welded to it and little wire supports set into it to hold the filament. The filament is draped on anchors and pinched fast to the ends of the leading-in wires. The stem with its filament is inserted in the bulb and the stem and bulb are fused together. The air is exhausted and gas inserted if it is to be a gas-filled lamp. The base is cemented on. The leading-in wires are soldered to the base. The lamp is tested, wrapped and packed in a carton and then in a case. It is one long succession of delicate little operations.

One of the difficulties has been the problem of maintaining a balance in the quantity of the different parts manufactured. This has led to the necessity for storage

THE INCANDESCENT LAMP

of parts between operations. It has required a great deal of floor space and an expenditure for labor in handling and rehandling materials. Various individual machines used in the different operations ran at their own particular speed of efficiency and the effort was to keep a balance amongst the number of machines or operators in each department that would maintain a uniform production.



UNIT MACHINE

In this machine, having four operators making standard lighting lamps, the heretofore individual processes in lamp making are co-ordinated. The result has been that the floor capacity of lamp factories has been tripled and the output per operator doubled.

Soon after the close of the war, when industrial men began to turn their thoughts once more to plant improvements, W. R. Burrows began to see the possibilities for correlating the machine steps in the manufacture of a lamp. His first move was to take one of the various machines out of each department and set them up side by side to work in sequence with each other and with the

THE INCANDESCENT LAMP

different hand operations required. There gradually developed the conception of balancing these machines and the hand work processes so that materials would flow evenly into the unit of machines and all storage of parts between operations might be eliminated.

By gradual evolution, the result of endless experiment and a tremendous amount of machine development, this very end was accomplished. Out of it finally came a unit lamp-making machine, one single combined mechanism into which glass bulbs, tubes and rods, filament wire, anchor wire, bases and packing materials are fed. Out of the other end come finished lamps, marked, tested, wrapped, packed and laid in a case upon a conveyor belt that carries them away to be shipped.

In the present unit machine there are three to seven operators, depending on the type of lamp, turning out twice as many lamps per operator as were made by the old departmental method. It is expected that machines will soon be available requiring a lesser number of operators, perhaps as low as two, in which much of the hand work now done will be made automatic. Another great advantage of the unit machine is that it has tripled the capacity for a given floor space, because it has eliminated the storage of parts between operations.

These advantages have materially reduced the cost of manufacture, making possible a reduction in prices. At the present time the price of lamps is more than one-third below the pre-war level, an accomplishment which few industries can claim and which is even more remarkable when it is considered that the present average price of commodities is over 50 per cent above their pre-war figure.

Another interesting thing about the unit machine is that the quality of lamps has improved through its use. This is due to the ability to locate definitely imperfect manufacture in any given part of the lamp which was almost impossible to fix by the old departmental method where the part may have been made in any one of a great many individual machines.

CHAPTER SEVEN

THE BASE

In the latter part of 1879, when Edison had invented a practical incandescent lamp, it was apparent that a device must be made whereby the lamp could be readily connected to the circuit. The first attempt at such a device consisted of wooden stand having two ordinary binding posts. As this required fastening the circuit wires to the binding posts each time the lamps were replaced, the danger of making a short circuit with the loose wires soon indicated the need for a socket and a base to fit into it.

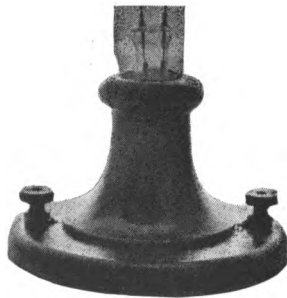

ORIGINAL LAMP BASE, 1879

This was before a socket had been invented, the circuit wires being attached to the binding posts on the wooden stand holding the bulb.

The first socket consisted of a hollow piece of wood containing two strips of copper, fastened at one end inside the wood on opposite sides of the socket. A thumb screw forced the two strips to make a rigid contact between two similar copper strips fastened to the neck of the bulb. One end of each of the copper strips on the lamp was soldered

THE INCANDESCENT LAMP

to the corresponding end of the leading-in wire and the other end was held against the neck of the bulb by wrapping string around it.

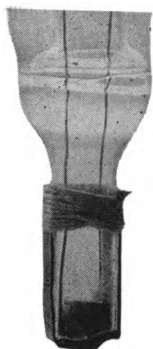

WIRE TERMINAL BASE, 1880

Copper strips were fastened to the end of the leading-in wires, the ends of the strips being secured to the neck of the bulb by string.

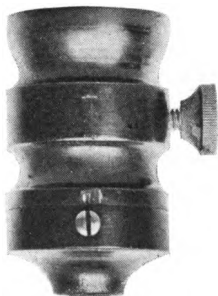

ORIGINAL SOCKET, 1880

This consisted of a hollow piece of wood containing two strips of copper. A thumb screw forced the two strips to make a rigid contact with the copper strips on the neck of the lamp, when the lamp was inserted in the socket.

This first base was superseded in the latter part of 1880 by a screw base. It consisted of a screw shell for one terminal and a ring for the other terminal. Wood was

CHAPTER SEVEN

THE BASE

In the latter part of 1879, when Edison had invented a practical incandescent lamp, it was apparent that a device must be made whereby the lamp could be readily connected to the circuit. The first attempt at such a device consisted of wooden stand having two ordinary binding posts. As this required fastening the circuit wires to the binding posts each time the lamps were replaced, the danger of making a short circuit with the loose wires soon indicated the need for a socket and a base to fit into it.



ORIGINAL LAMP BASE, 1879

This was before a socket had been invented, the circuit wires being attached to the binding posts on the wooden stand holding the bulb.

The first socket consisted of a hollow piece of wood containing two strips of copper, fastened at one end inside the wood on opposite sides of the socket. A thumb screw forced the two strips to make a rigid contact between two similar copper strips fastened to the neck of the bulb. One end of each of the copper strips on the lamp was soldered

THE INCANDESCENT LAMP

to the corresponding end of the leading-in wire and the other end was held against the neck of the bulb by wrapping string around it.

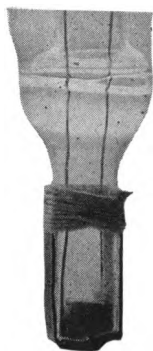

WIRE TERMINAL BASE, 1880

Copper strips were fastened to the end of the leading-in wires, the ends of the strips being secured to the neck of the bulb by string.

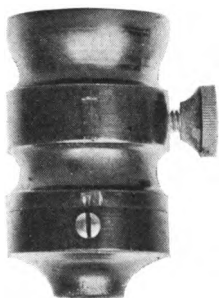

ORIGINAL SOCKET, 1880

This consisted of a hollow piece of wood containing two strips of copper. A thumb screw forced the two strips to make a rigid contact with the copper strips on the neck of the lamp, when the lamp was inserted in the socket.

This first base was superseded in the latter part of 1880 by a screw base. It consisted of a screw shell for one terminal and a ring for the other terminal. Wood was

THE INCANDESCENT LAMP

used to insulate and hold together the parts of the base. The base was cemented to the neck of the bulb by plaster of paris. This base was large and bulky and was soon

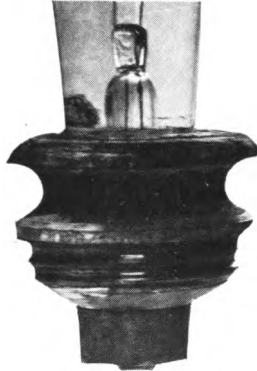

ORIGINAL SCREW BASE, 1880

This was the first screw base. It consisted of a screw shell and a ring for terminals with wood for insulation. It was fastened to the bulb by plaster of paris and was a bulky affair.



ORIGINAL SCREW SOCKET, 1880

This was made of wood, the copper terminals inside being designed to accommodate the original screw base pictured above.

changed, early in 1881, to a smaller sized base having a cone-shaped ring and screw shell for terminals. Soon

THE INCANDESCENT LAMP

afterward the use of wood for insulation was abandoned, plaster of paris being used instead, both for insulation and to hold the two parts of the base together and to the bulb. It was found, however, that when the lamp was firmly screwed into the socket, the pressure of the cone-shaped ring terminal of the socket against the similar terminal of the



IMPROVED SCREW BASE, 1881

The terminals of this smaller base were a cone shaped ring and a screw shell with wood insulation.



PLASTER SCREW BASE, 1881

To simplify matters, the wood insulation was omitted, plaster of paris being used for this purpose as well as for fastening to the bulb.

base produced a tension on the plaster of paris between the two terminals of the base so that it was liable to be pulled apart.

A few months later, about the middle of 1881, this difficulty was overcome by changing the base terminals to a screw shell and an end contact so that by screwing the base in the new socket, changed of course to fit the base, pressure instead of tension was put on the plaster of

THE INCANDESCENT LAMP

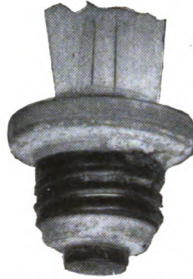

FINAL SCREW BASE, 1881

In the previous base, it was found that when the lamp was firmly screwed in the socket a tension was produced on the plaster insulation between the two terminals so that the base was apt to be pulled apart. This was overcome by changing the terminals to a screw shell and an end contact, as illustrated, producing a pressure instead of tension on the plaster insulation. This arrangement has been used ever since, and this base will fit present day sockets.



EDISON LAMP, 1884

The ring of plaster about the neck of the bulb, heretofore used as handle, was omitted in 1884.

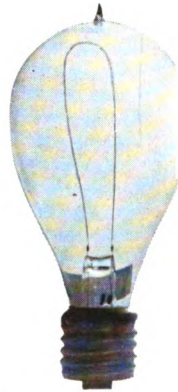

EDISON LAMP, 1888

The length of the base was increased in 1888 so that it had more threads.

THE INCANDESCENT LAMP

paris insulation. This arrangement of the terminals for the base is the same as is standard today. While slight dimensional modifications have since been made, this base will fit present day sockets. This screw base, generally known throughout the electrical industry as the Edison base in honor of its inventor, has become the world

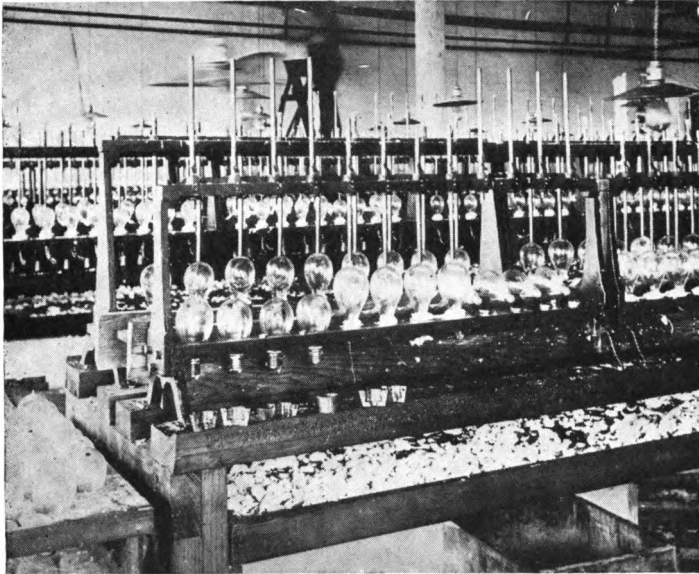

BASING RACK

This was used in basing lamps when plaster of paris was used.

wide standard and lamps fitted with it are annually made throughout the world in quantities many times greater than the combined quantity of lamps fitted with all other bases.

The base had a ring of plaster about the neck of the bulb for use as a handle to screw the lamp into the socket.

THE INCANDESCENT LAMP



FINAL SCREW BASE, 1881

In the previous base, it was found that when the lamp was firmly screwed in the socket a tension was produced on the plaster insulation between the two terminals so that the base was apt to be pulled apart. This was overcome by changing the terminals to a screw shell and an end contact, as illustrated, producing a pressure instead of tension on the plaster insulation. This arrangement has been used ever since, and this base will fit present day sockets.

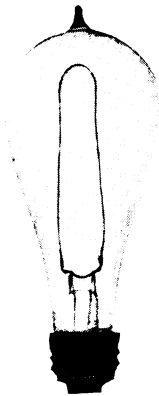

EDISON LAMP, 1884

The ring of plaster about the neck of the bulb, heretofore used as handle, was omitted in 1884.

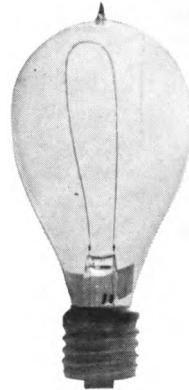

EDISON LAMP, 1888

The length of the base was increased in 1888 so that it had more threads.

THE INCANDESCENT LAMP

paris insulation. This arrangement of the terminals for the base is the same as is standard today. While slight dimensional modifications have since been made, this base will fit present day sockets. This screw base, generally known throughout the electrical industry as the Edison base in honor of its inventor, has become the world

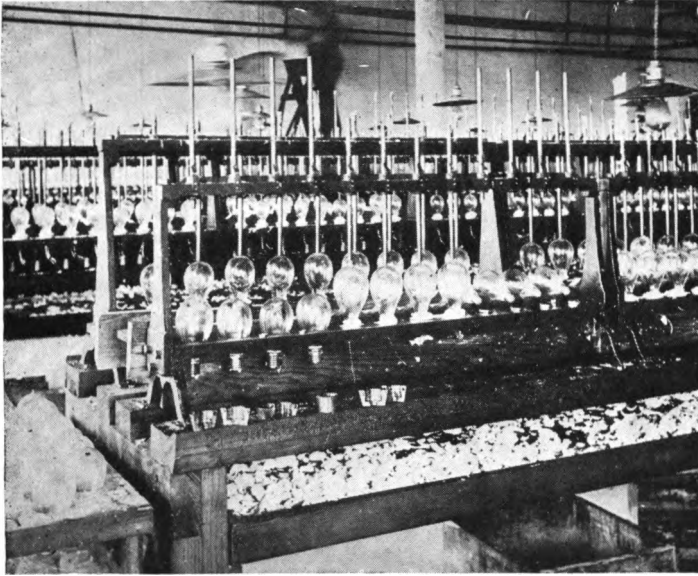

BASING RACK

This was used in basing lamps when plaster of paris was used.

wide standard and lamps fitted with it are annually made throughout the world in quantities many times greater than the combined quantity of lamps fitted with all other bases.

The base had a ring of plaster about the neck of the bulb for use as a handle to screw the lamp into the socket.

THE INCANDESCENT LAMP

In 1884, this ring of plaster was omitted. In 1888, the length of the screw shell was increased, more threads being put on. Owing to the fact that the necks of the free blown bulbs used were not of uniform size, various lengths of screw shells had to be used to fit the various lengths of bulb necks. With the adoption of the moulded bulb, this requirement was no longer necessary.

The method of attaching the base to the lamp was to put the two terminals in a mould mounted on a rack, pour plaster of paris in the mould, thread one leading-in

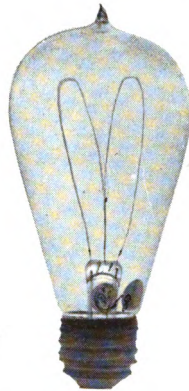

EDISON LAMP, 1900

Moulded porcelain was used for insulation in the base which was fastened to the bulb with a waterproof cement in place of plaster of paris.

wire through the hole in the end contact terminal, bend the other leading-in wire back on the neck of the lamp and insert the neck of the lamp in the mould. Guides on the rack were lowered over the tip of the lamp, to align the lamp and base properly, and the plaster allowed to dry. The plaster of paris became fairly hard in about twenty minutes, when the mould was removed and the lamp with its base put in a heated enclosure to drive out the

THE INCANDESCENT LAMP

moisture from the plaster, a process requiring about 36 hours. The excess length of the leading-in wires was then cut off, their ends being soldered to the base.

Waterproof Base

The plaster of paris would absorb moisture when the lamp was used in exposed places, such as in outdoor signs. In 1900, porcelain insulation was used to hold the parts of the base together, the base being fastened to the bulb by a waterproof cement. This cement consisted of plaster

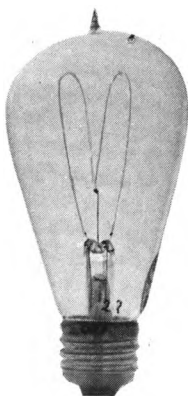

EDISON LAMP, 1901

Glass was used in the base for insulation in place of porcelain. This is the same as used today.

of paris with a shellac solution which, when heated, made a hard waterproof cement through the evaporation of the alcohol in the shellac. The tensile strength of the cement was later improved by substituting Portland cement, or in some cases marble dust, for the plaster of paris. Bakelite is now used and, in order to determine whether or not it is heated to the proper temperature, a green dye is mixed with the powdered bakelite, the dye decomposing at a certain temperature so that the green color disappears.

THE INCANDESCENT LAMP

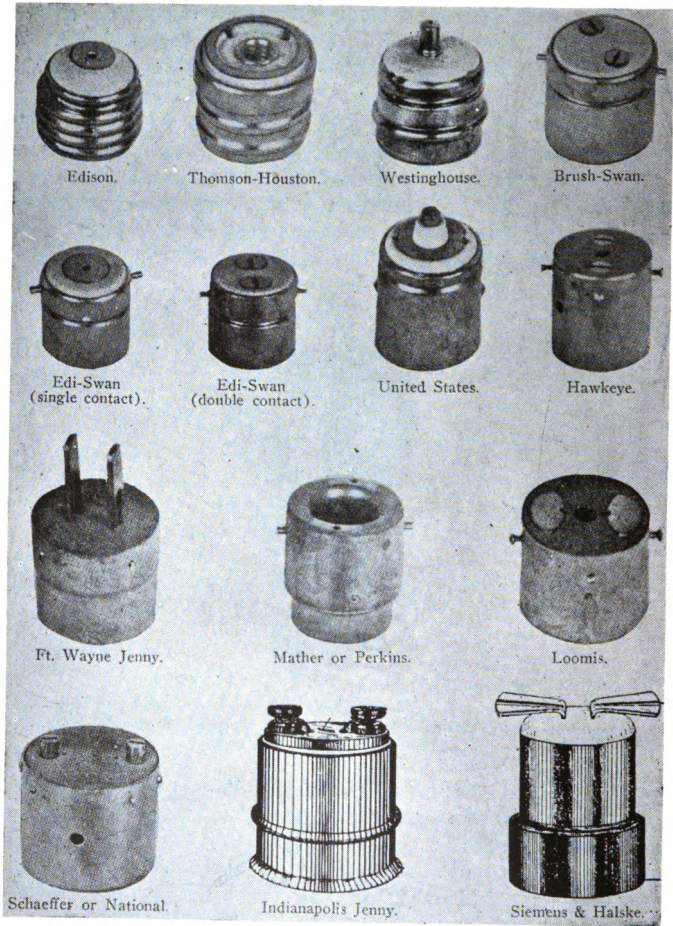

SOME OF THE VARIOUS BASES IN USE PRIOR TO 1900
 A few of these had disappeared from use, the proportion in 1900 being 70 per cent Edison, 15 per cent Westinghouse, 10 per cent Thomson-Houston, and 5 per cent for the others remaining.

THE INCANDESCENT LAMP

In 1901, glass was used to insulate and hold the terminals of the base, this being made possible by an invention by Alfred Swan, of the General Electric Company. This greatly reduced the cost of the base, and all bases are now so made. A fine stream of molten glass is allowed to flow in a holder containing the screw shell and the end contact. When a sufficient amount of molten glass has been put in, a jet of air blows the stream of glass to one side—it cannot be



Thomson-Houston



Westinghouse

ADAPTERS FOR EDISON BASE LAMPS

The adapter placed in the socket permitted the use of lamps fitted with Edison base.

shut off as it would otherwise freeze up in the orifice—and a plunger is inserted which shapes the glass, leaving a hole through which the leading-in wire can be inserted and soldered to the end of the base.

Other Bases

Soon after the commercial introduction of Edison's lamp, many other concerns began making lamps, each with an individual design of base. This required a corresponding socket to fit the base and no less than fourteen different designs were in use at one time or another.

In 1900, the more important designs in use were the Edison, which covered about 70 per cent of the total, the

THE INCANDESCENT LAMP

Westinghouse, 15 per cent and the Thomson-Houston 10, per cent. The remaining 5 per cent covered the other designs.

Standardizing the Edison Base

As the use of incandescent lamps became more general and the necessity arose for more types of lamps to meet individual specific requirements, together with the need of stocks at convenient distributing points throughout the country to supply the demand promptly, the existence of so many different lamp bases presented a situation which, if continued, would seriously retard the development of the electric lighting industry. The necessity for overcoming this condition seemed imperative and it was recognized that something must be done to simplify the lamp base problems.

The task seemed insurmountable. At this time, 1900, there was an aggregate of about fifty million sockets of various designs in use in the United States. It seemed desirable to standardize on the Edison base and socket because of the simplicity of its design and extent of its use. To change the sockets of the types other than Thomson-Houston and Westinghouse to the Edison type of socket was considered possible, but to replace every Thomson-Houston and Westinghouse socket with an Edison screw socket was thought impossible. It appeared, however, that adapters could be designed to enable existing Thomson-Houston and Westinghouse sockets to receive lamps fitted with the Edison screw base, but even this was considered by many to be impossible of accomplishment commercially. Nevertheless, believing that it should at least be tried, the adapters were designed and made, being sold at cost.

The campaign, which was started to effect the corresponding changes commercially, was so successful that in less than five years the demand for lamps in the United States with other than the Edison base practically ceased. At the present time, the five hundred million sockets now in use in this country on commercial lighting circuits are all of the Edison screw type.

CHAPTER EIGHT

PHOTOMETRY

The incandescent electric lamp is responsible for the great development which has taken place in the art of photometry. Before Edison invented his lamp, photometry was a crude art and was little used. Laboratories and some gas plants had photometers, using as standards of light either candles or oil lamps, both of which were so variable that there were no really dependable standards. Even though the law in some states specified that a gas burner which consumed five cubic feet an hour, should give sixteen candle power, some gas companies that had photometers rarely used them.

The method then in use was to burn two standard candles at one end of the photometer as a standard of light. These candles were set in a balance which weighed the consumption of material per minute while the measurements were being made, and measurements were then corrected for variations from the specified rate of consumption of the candles. The light given by these candles varied with other conditions, such as the length of the wick, for example, but it was a rule not to trim the wicks during the measurements. In fact the public was not much concerned with candle power at that time.

When incandescent electric lamps came into use, their candle power and efficiency at once became matters of great importance and interest. Edison claimed to get eight 16-candle power lamps per horse power of electricity and constant tests were made to see that the lamps made each day met this condition. Candles were used as the standards of light, but their daily use in the photometers was soon superseded by carefully standardized incandescent lamps. These standard lamps burned as long as the photometer was in use, which was usually all day, and were

THE INCANDESCENT LAMP

frequently checked and corrected by comparison with a number of other carefully prepared lamps used only for this purpose. This method of photometry originated in the laboratory at Menlo Park and has been the universal method ever since.

Every lamp made was measured to determine the voltage at which it gave 16 candle power. This voltage was measured by means of a reflecting electro-dynamometer

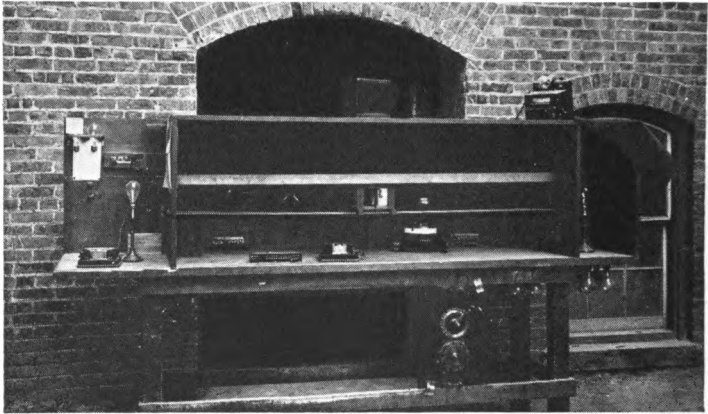

STANDARD PHOTOMETER

This measures the mean horizontal candle power of lamps. At the right, the standard lamp is set, against which the lamp to be photometered (on the left) is balanced. The voltage and current taken by the lamp being photometered is measured at the same time.

made for the purpose. The scale read to 150 volts and each volt near the hundred volt mark gave a deflection of about three-sixteenths of an inch on the scale. The measurements were made on a circuit of 150 volts, resistance being put in series with the lamp to reduce the line voltage to that required on the lamp, which was measured by the electro-dynamometer. The voltage of the line was held constant at 150 volts by manual regulation.

THE INCANDESCENT LAMP

There were no ammeters at that time. The resistance in series with the lamp when it was being measured was in steps of one ohm each. The voltage on the lamp was read on the electro dynamometer and the resistance in series with the lamp was noted. The difference between 150 volts and the voltage on the lamp was the voltage on the variable resistance and this voltage divided by the resistance noted was the current passing through the lamp. All lamps at that time were measured at 16 candles and curves drawn on cross section paper made it possible to determine the candles per horse power which the lamp gave with the known voltage on the lamp and the resistance in series with it on the 150-volt circuit.

Each lamp, being rated to consume one-eighth of an electrical horse power, was therefore designed for $93\frac{1}{4}$ watts (one-eighth of 746). The correctness of the power measurements was checked by burning a lamp in a calorimeter and measuring the rise in temperature of the water during a measured time. The calorimeter method was well worked out in its details and gave quite good results. This method of measuring lamp efficiencies continued until about 1890, when reliable voltmeters and ammeters were developed by Edward Weston. It was not necessary to measure the efficiency of every lamp made, but it was necessary to photometer every lamp manufactured to determine the voltage at which it gave its rated candle power.

The first test department was established at the laboratory in Menlo Park, in 1880. In March, 1881, a much more complete test department was set up in the Lamp Factory at Menlo Park by Dr. Edward L. Nichols. In April, 1882, the Lamp Works moved to Harrison and with it the test department. In 1887, the test department was moved to Edison's new laboratory at Orange, N. J., and in 1893 it was moved back to Harrison.

About 1886 J. T. Marshall, of the General Electric Company, invented a method of determining the voltage at which a lamp gives its rated candle power without requiring the

THE INCANDESCENT LAMP

use of any electrical measuring instrument. At one end of a photometer he placed a seasoned lamp of the type to be measured on the photometer and of a known voltage, which was the voltage for which the lamps to be measured were designed. The lamp to be measured was placed at the other end of the photometer and the two were connected in multiple so that both had the same voltage acting on them. If the lamp being measured was of the same

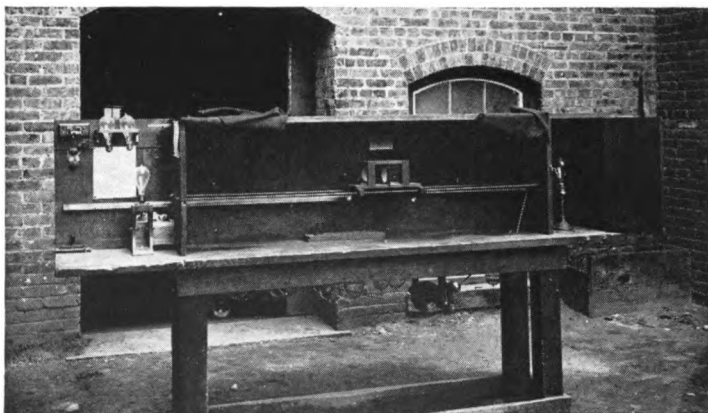

SLIDING SCALE PHOTOMETER

In this photometer lamps were measured for their voltage to give their rated candle power without the use of electrical measuring instruments. An empirical scale attached to the balancing screen (in the center) gave the voltage.

voltage as the standard lamp, they would both give the same candle power and the photometer spot would balance in the center of the scale, this point being marked as the voltage of the standard lamp. If the two lamps differed in voltage, they would also differ in candle power and the balancing position of the spot would indicate the voltage of the lamp being measured, by means of an empirical scale.

THE INCANDESCENT LAMP

Voltage fluctuations on the line did not affect the results in this method as the two lamps varied similarly, so this photometry was done on a line which was not carefully regulated. This method allowed very fast operation and was a great boon to photometer work. This "sliding scale" or "same circuit" photometer was in regular use until the advent of the drawn tungsten wire lamp in 1911, when it was no longer necessary to photometer each drawn tungsten wire lamp. Every carbon, GEM, tantalum and pressed filament tungsten lamp had to be photometered individually to determine its voltage.

The reason why it was not necessary to photometer drawn tungsten wire lamps was that the filament could be made to such an exact diameter and length that each lamp could be manufactured to extreme closeness of candle power and efficiency. Sample lamps were photometered to check the manufacture, and the lamps usually came out so close to their designed rating that if the photometric measurements were found to differ from the designed rating, the chances were that there was an error in the photometric readings.

Carbon lamps were all measured for mean horizontal candle power, because they varied in candle power in different parts of the horizontal plane. It was the practice at first to select an average position and measure the lamps in this position. Later the lamps were rotated about their vertical axis while being measured in the photometer, their average horizontal candle power being obtained in this way.

The relation of the horizontal candle power of each type of lamp to its spherical candle power was known. The spherical candle power is the average candle power in all directions. The relation between the two, known as the reduction factor, was 0.825 for the oval anchored carbon lamp, so that its spherical candle power could be determined by taking $82\frac{1}{2}$ per cent of its horizontal candle power measurement.

THE INCANDESCENT LAMP

When tungsten filament lamps were developed in many forms of filament shapes, their ratios of horizontal to spherical candle power varied a great deal. It therefore became advisable to change all ratings to the basis of spherical candle power, which eventually became standard practice. The spherical candle power can readily be measured by burning the lamp in a hollow sphere which has a matt-white inside surface. The cross reflections inside

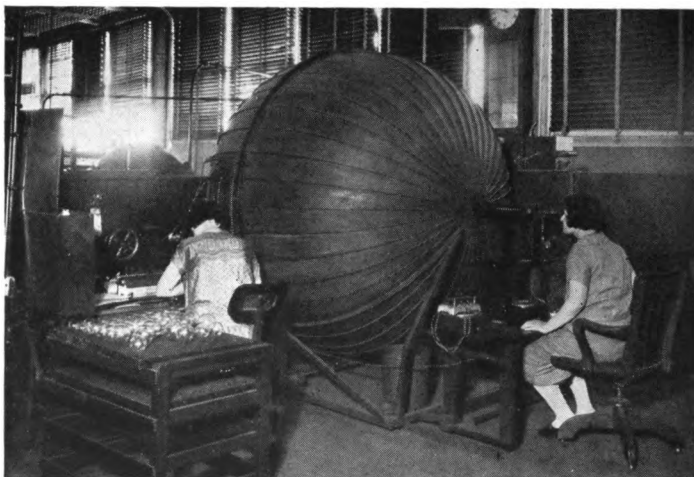

SPHERICAL PHOTOMETER

With this photometer the spherical candle power of a lamp, the average candle power it gives in all directions, can be obtained by but one measurement.

the sphere, coming from the light thrown out in all directions by the lamp being measured, fall on a diffusing glass test plate located on the periphery of the sphere, the direct light from the lamp being screened from the test plate. The light from the test plate is balanced by a standard lamp and therefore gives, in one reading, the spherical candle power of the lamp being measured.

THE INCANDESCENT LAMP

In the early days the efficiency of lamps was measured in candles per horse power. Later the name **WATT** was given to the unit of electric power and after that lamp efficiencies were stated in watts per candle. The candle in both cases was the horizontal candle power. With the measurement of lamps in spherical candle power, the lamp efficiency was stated in watts per spherical candle. The two terms, watts per candle (wpc) and watts per spherical candle (wpsc), often led to confusion, so that efficiency came to be designated by the term lumens per watt (LPW). This term LPW has an advantage in that the higher the efficiency, the higher the LPW becomes numerically, whereas the reverse obtains with the terms wpc and wpsc.

The lumen is the unit of light flux, and the efficiency of all lamps is now measured in LPW. The lumens delivered by any lamp are 12.57 times its spherical candle power. A lumen is the light flux which a point source of one candle power of light will throw upon a surface of one square foot, every point of which is located one foot distant from the point light source. So if a light source of one spherical candle is placed at the center of a sphere of one foot radius, it will yield as many lumens as there are square feet on the inside surface of this sphere, or 12.57 lumens.

In all photometric work, the light of the lamp under test is compared with the light given by a working standard lamp, the correctness of this working standard lamp being frequently determined by comparing its light with that given by a number of photometric standard lamps kept for the purpose. Hitherto all practical photometric measurements have been made by a visual comparison of the lamp to be measured with the standard lamp and, therefore, have depended on the judgment of the eye.

Photometry is not the measurement of an external or objective dimension, but of a sensation, and it is difficult to make a quantitative measurement of our sensations. The attempt to apply measurement to the sensation of smell has not met with success. In spite of the delicacy with which different sensations of taste may be discrimi-

THE INCANDESCENT LAMP

nated, it has been impossible to measure taste, particularly as there seem to be physiological reasons for a rapid approach to a saturated condition of the sensation. A similar difficulty arises in the action of light on the eye.

Many attempts have been made to develop a practical method of photometry which did not depend for its accuracy on the human element. Among them may be mentioned the Thermopile, and the Bolometer, which have both been used to measure the whole radiant energy given out by a lamp. This was done by means of electrical apparatus, the dark heat rays being filtered out from the luminous rays by a process of selection. The proportion of energy in the luminous rays is so small compared with the thermal or heat energy rays that it has been impossible to arrive at any precise measurement of light alone. The electrical properties of selenium have given some promise of a quantitative indication of the intensity of light. Photographic methods have been suggested and tried by exposing strips of sensitized paper for a definite time and comparing them with the shades obtained from known illuminations. None of these schemes has been able to compete in a practical way with an ordinary visual photometer.

Recently, however, Charles Deshler, of the General Electric Company, has developed a photometer which substitutes a "mechanical" eye for the human eye. The comparison of light sources, the photometer spot and the working standard lamp have been entirely eliminated. The lamp whose lumens are to be measured is placed as usual in the sphere of a spherical photometer. The integrated light of the lamp passes through a suitable color filter, or test plate and filter, and impinges on a photo-electric cell. A suitable potential is placed across the cell, and the current flowing under these circumstances is proportional to the lumens given by the lamp. This current is measured by a microammeter or galvanometer which thus becomes a "lumen-meter". The photometer is extremely accurate, eliminates the varying human element of the eye, and is much more rapid than any visual photometer.

THE INCANDESCENT LAMP

The principle of the photo-electric cell is based on an electrical property of alkali metals when subjected to light. When the surface of such alkali metals as potassium, barium, strontium, sodium, etc., is exposed to light, it liberates electrons like the heated filament in a radio tube. The cell usually consists of a glass bulb with two terminals. One, the positive terminal, is at the center of the bulb and



PHOTO-ELECTRIC CELL

This consists of a glass bulb, coated on the inside with an alkali metal compound, which emits electrons when subjected to light, so that the strength of the current flowing from this coating to a positively charged terminal in the bulb is a measure of the candle power of the light.

is equivalent to the plate of a radio tube. The other, the negative terminal, consists of an alkali metal film deposited on the inner surface of the bulb, and is equivalent to the filament in a radio tube. This metal film covers the entire inner surface of the glass bulb except for one clear spot, called the "window," through which the light to be measured can enter the interior of the bulb. When an electrical

THE INCANDESCENT LAMP

circuit outside the cell is established through a battery, with the positive of the battery connected to the center (positive) terminal and the negative battery terminal connected through a galvanometer to the metal film (negative) terminal of the cell, the electrons emitted from the metal film will be attracted to the positive terminal inside the bulb, as in a radio tube, and then will flow through the outside circuit back to the negative metal film.

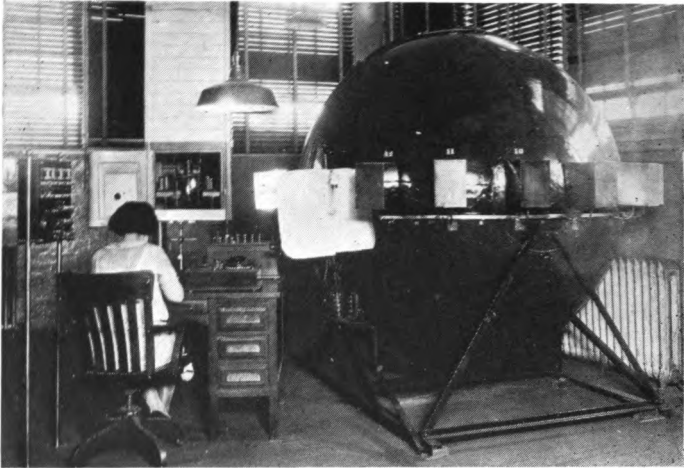

SPHERICAL PHOTOMETER WITH PHOTO-ELECTRIC CELLS

The light from the lamp to be photometered falls on the photo-electric cells mounted on the outside equator of the sphere. The current flowing through the cells passes through a galvanometer which deflects a ray of light on a scale and thus indicates the candle power of the lamp being photometered.

This flow of electrons is the modern theory of the flow of electric current, and as the number of electrons emitted by the metal film depends upon the intensity of the light thrown on it, the strength of the electric current in the outside circuit becomes a measure of the intensity of the

THE INCANDESCENT LAMP

light. While this current is minute, of the order of a few millionths of an ampere, it can be measured by a microammeter or by the deflection of a galvanometer needle.

Potassium hydride, an alkali metal compound, is now generally used as the metal film on account of its relatively high melting point and sensitivity. The bulb is highly evacuated and filled to low pressure with an inert gas such as argon, helium, etc. The introduction of these gases produces ionization by collision of the electrons with the molecules of gas in the bulb so that a given intensity of light thereby greatly increases the strength of the current through the cell.

There are two essential difficulties which had to be overcome before the cell could be used satisfactorily for photometric purposes. The first is color sensitivity; that is, the cell responds to certain colors of the spectrum to a greater extent than does the human eye. This was the main difficulty which previously precluded the use of the cell, but it was overcome by the use of a color filter of the proper color. Lamps of equal candle power to the human eye, but which are different in efficiency, have different proportions of the various colors making up the light which they give and so the cell, without a proper filter, would indicate different candle powers. This would mean that, for example, a 100-watt MAZDA C lamp, which is about twice as efficient as a 10-watt MAZDA B lamp, but whose light is much whiter than that of the latter, would be indicated by the cell as giving more than twenty times the difference in candle power between the two lamps as seen by the human eye.

The second difficulty, the minuteness of the current, has been overcome by using a high sensitivity galvanometer or microammeter. With lamps of very low candle power more than one cell can, if necessary, be used in multiple to increase the amount of current.

Life Testing

After the invention of the lamp by Edison, two great questions had to be answered: how much power is

THE INCANDESCENT LAMP

required to operate the lamp and how long will the lamp last? In those days the power required to operate a lamp was expressed by the number of candles produced per horse power of electricity consumed. It was immediately observed that the candles per horse power became greater



LIFE TEST RACKS.

This photograph shows part of the equipment used in life testing lamps at the Edison Lamp Works.

as the temperature of the filament was raised, and it was also observed that as the temperature was raised the life of the filament became shorter. Edison concluded that a lamp to be satisfactory must last about 600 hours, and tests were started to determine the candles per horse power at which the lamps would last 600 hours—so a life test department was created in 1880 at the laboratory at Menlo Park. Early in 1881, a much better one was set up in the Lamp Factory at Menlo Park.

THE INCANDESCENT LAMP

The life test department made it possible to rate lamps as improvements were made so that they would last 600 hours, and to determine the worth of experimental lamps, so its importance and value were recognized from the beginning. Life testing lamps at their normal rating took a long time, so, as early as 1880, tests at higher than normal rating were regularly made. Lamps were life tested at three times their normal candle power, 16-candle lamps being tested at 48 candles. As lamps improved in quality, this was changed to 64 candles and then to 80 candles.

For this testing a special generator was used, which was held at 150 volts, being regulated by hand. A resistance was placed in circuit with each lamp, which could be adjusted in steps of one ohm up to 100 ohms, so that any lamp could be burned at practically any desired voltage up to 150 volts. From the results of these tests of lamps, J. W. Howell determined in 1885 the relative lives of lamps at different initial candle powers. He found that the lives of lamps varied inversely as the 3.65ths power of their initial candle power. This exponent has been redetermined and checked several times since then by different people. Later, lamps were tested, not at fixed candle powers, but at fixed watts per candle, and recently at lumens per watt, this being now accepted as the measure of the efficiency of lamps.

The necessity of life testing is just as great now as it was in the early days. Samples from the regular production of every factory are frequently and regularly tested to keep the makers informed of the quality of lamps made, and many experimental lamps from the development and research laboratories are constantly being life tested as an ultimate test to determine their success or value. Lamps are also tested for filament strength, brittleness, ductility, sagging, etc., and each test necessitates the destruction of the lamps tested in order to determine their ultimate characteristics. These tests have to be made with the greatest accuracy and care, the maintenance of the life test department costing a great deal of money and its work destroying a great many lamps.

INDEX

	PAGE		PAGE
Ampere, A. M.....	13	Wheatstone.....	19, 22
Andrus, M.....	46	Woolrich.....	19
Bases.....	182	Edison Elec. Ilg. Co. of N. Y. 71	
Batchelor, C.....	46	Edison Elec. Lt. Co.....	48, 58
Batteries.....	11	Edison Lamp Co.....	64
Bergman & Co.....	67	Edison Machine Works.....	67
Boehm, L. K.....	46	Edison, T. A.....	46, 115, 148
Bradley, J.....	64	Efficiency of Lamps... 83, 199	
Branin, M. H.....	172	Electric Tube Co.....	68
Brauner, J. C.....	76	Farmer, M. G.....	34, 41
Bulbs.....	163	Filaments:.....	75
Burnett, H. D.....	172	Coolidge, drawn tungsten 101	
Burrows, W. R. 163, 169, 180		Edison, Carbon... 56, 61, 75	
Carbonizing.....	56, 75	Just & Hanaman, Tung-	
Carman, G. E.....	46	sten.....	94
Clamps.....	77, 156	Pacz, Non-sag Tungsten 119	
Columbia, S. S.....	61	Powell, Cellulose.....	81
Coolidge, Dr. W. D.....	101	Swan, Parchmentized... 37	
Cunningham, D.....	46	Von Bolton, Tantalum... 90	
Dean, G.....	46	Welsbach, Osmium..... 88	
Deshler, C.....	200	Whitney, Gem.....	84
Doane, S. E.....	172	Fink, Dr. C. G.....	131, 160
Dumet.....	160	Flammer, C.....	46
Dyer, P. S.....	64	Force, M. N.....	46
Dynamos.....	16	Friederich, E.....	136
Alliance.....	22	Frosting.....	176
Alteneck.....	25	Fuse.....	66
Brett.....	19	Gas-filled Tungsten Lamp. 137	
Clarke.....	18	Gem Lamp.....	84
Edison.....	51, 69	General Electric Co.....	41, 49
Faraday.....	16	Getters.....	127
Gramme.....	23	Gill, F. W.....	136
Hjorth.....	21	Glass.....	163
Nollet.....	22	Griffin, S. L.....	46
Pixii.....	17	Haid, Dr. A.....	46
Pulvermacher.....	20	Hammer, Maj. W. J. 48, 53, 64	
Siemens.....	21, 24	Hanaman, F.....	94
Sinstenden.....	20		

INDEX (Cont'd)

PAGE	PAGE
Hannington, C. F.	77
Herald, N. Y.	58
Hinds Ketcham & Co.	63
Holzer, W.	168
Houston, E. J.	41
Howell, J. W. 80, 166, 170	
Incandescent Lamp Inventors	
Bottome	93
Bouliguine	40
Davy	16, 25
DeChangy	33
De LaRue	25
DeLodyguine	94
DeMoleyn	27
Edison	48, 53, 57, 60, 65
Farmer	34, 42
Grove	26
Just & Hanaman	94
Konn	39
Kosloff	39
Langmuir	137
Lodyguine	38
Maxim	43
Roberts	32
Sawyer	42
Shepard	32
Staite	30
Starr	28
Swan	34
Von Bolton	90
Whitney	84
Jaeger, H. J.	174
Jehl, F.	46, 57
Just, A.	94
Kelly, J. F.	46
Kuzel, Dr. H.	99
Langmuir, Dr. I.	137
Lawson, J. W.	46
Leading-in Wires	159
Logan, T.	46
Lumens-per-watt	83, 199
Malignani, A.	126
Man, A.	43, 79
Marshall, J. T.	128, 195
Mazda	100
McGowan, F.	77
McLaughlin, Maj. F.	46
Menlo Park	45, 60
Meridian Lamp	172
Metallized Carbon Filament	84
Meter, Edison Chemical	68
Mitchell, L. E.	175
Moore, W. H.	77
Needham, H. H.	134
New York Edison Co.	71
Nichols, Dr. E.L.	195
Novak Lamp	127, 150
Ohm, G. S.	14
Osmium Lamp	88
Ott, J. F.	46
Pacz, Dr. A.	121
Pearl Street Station	70
Photo-electric Cell	201
Photometry	193
Pipkin, M.	177
Powell, L. S.	81
Randolph, J. F.	46
Ricalton, J.	76
Sawyer-Man Elec. Co.	43
Sawyer, W. E.	42, 79, 149
Sealing-in	169
Seymour, J.	46
Skaupy, F.	132
Sprengel Mercury Pump	35, 123
Stem	156, 165
Swan, A.	191
Swan, Sir J. W.	34, 82
Swanson, A.	46
Tantalum, Lamp	90
Thomson-Houston Co.	41, 166
Thomson, Prof. E.	41
Thoria	119

INDEX (Cont'd)

	PAGE		PAGE
Three-wire System.....	72	Volta, A.....	11
Tipless Lamp.....	170	Von Bolton, Dr. W.....	90, 99
Treating Process.....	79	Von Welsbach, Dr. C. A....	88
Tubulating.....	168		
Tungsten Lamp.....	94	Wallace, W.....	41
		Wardlaw, F. A.....	47
Unit Machine.....	179	Waring, J.....	127
Upton, F. R.....	46, 64	Westinghouse Lamp Co.....	44, 94
		Weston, E.....	41, 195
Vacuum.....	123	White, A. J.....	175
Van Keuren, W. L.....	161	Whitney, Dr. W. R.....	84

GE
11
06
88
1
7
4
1

UNIVERSITY OF MICHIGAN



3 9015 06395 0698

518742

**DO NOT REMOVE
OR
MUTILATE CARD**

