



The Top End

Julianne Knott and Charlie Van Allen

Overview

Parts:

- Cylinder
- Cylinder Head
- Piston
- Valves
- Valve Springs
- Rocker Arms
- Push Rods

What We Did:

- Take Everything Apart
- Clean and Sandblast
- Cut the Valve Seats
- Lapping the Valves
- Replace the Piston
- Rebore the Cylinder
- Put It Back Together!

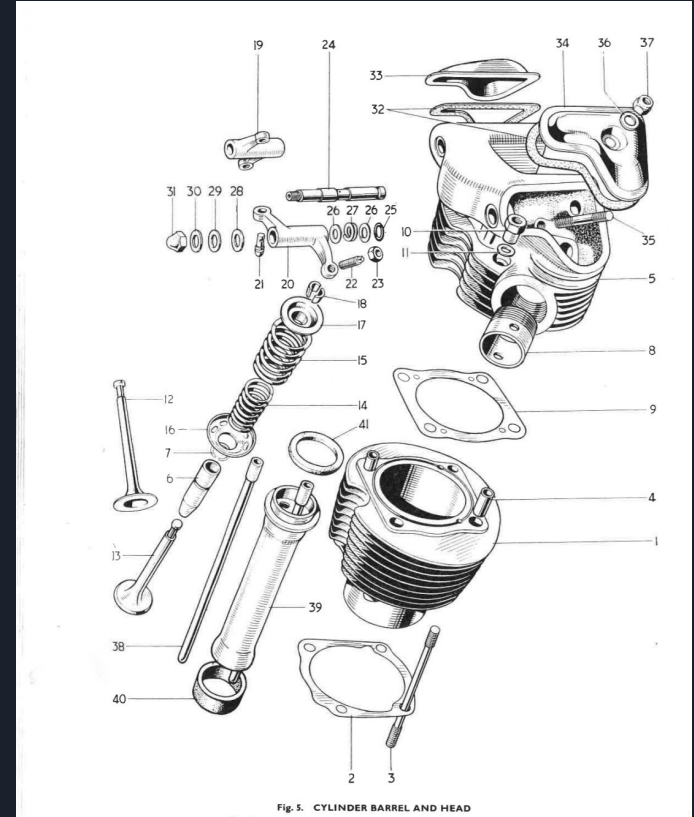

Cleaning, Sandblasting, and Glass Beading



Why We Did It:

- To make the parts look nicer, identify missing and broken pieces, and make the engine run smoother over all.

How We Did It:

- We used the parts cleaners to wash off excess oil and grime.
- We used the sand blaster to remove the toughest layers of dirt.
- We used the glass beader to give it a smoother appearance.
- In order to properly glass and/or sand bead we had to cover the inner surfaces, as seen to the left, in order to keep the innards of the engine untouched by the sandblasting
- If we were to not tape over the cylinder or the valves, the sandblasting would have offset the measurements within the cylinder and valves.

Cutting the Valve Seats

Why We Did It:

- It's important for the valves to sit flush in the valve seats to form a proper seal.
- The better the seal, the better the efficiency of the engine.

How We Did It:

- We used the valve cutter with the proper diameter and angle and rotated it in the valve seat.
- We used machinist's bluing to ensure that the cut was even along all sides of the valve seat.
- The 'bible' had all of the proper measurements that we should have been using, allowing us to choose the proper diameter in which to cut the valves.



Lapping the Valves and Valve Seats



Why We Did It:

- It's important that the valves fit the valve seats exactly so that the seal formed between the two is 100% complete.

How We Did It:

- We applied valve lapping compound to the surface and used the plunger tool to spin the valves in the valve seats.
- We used machinist's bluing to ensure that all the surfaces were evenly lapped.
- The valve lapping compound ensured for an even cut on the seats.

Replacing the Piston

Why We Did It:

- The old piston was burnt, damaged, and gross looking.
- The Cylinder was worn out and needed to be rebored, thus requiring a larger piston.

How We Did It:

- We went to the bunker and looked around for a suitable piston. We needed one that was slightly bigger than the one we had so that when we rebored the cylinder, it would fit exactly.

Fun Fact:

- The Piston is actually elliptical in shape because it is designed so that when the engine is running it heats up and expands to form a perfect circle.



Reboring the Cylinder

Why We Did It:

- It's important to make sure the cylinder and piston fit perfectly with one another so that the engine is as efficient as possible without seizing up.

How We Did It:

- Glen used the lathe to cut the hole in the cylinder to the proper diameter
- Then we honed the cylinder to make the surface more porous so that it would better retain oil.
- Furthermore, we ordered the correct diameter piston online with the help of Professor Littman.

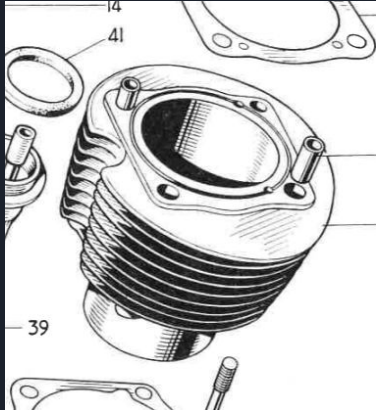

Putting it Back Together!

Key Challenges:

- Compressing the Springs
- Inserting the push rods
- Inserting the rocker arms
- Checking the lash with the feeler gages

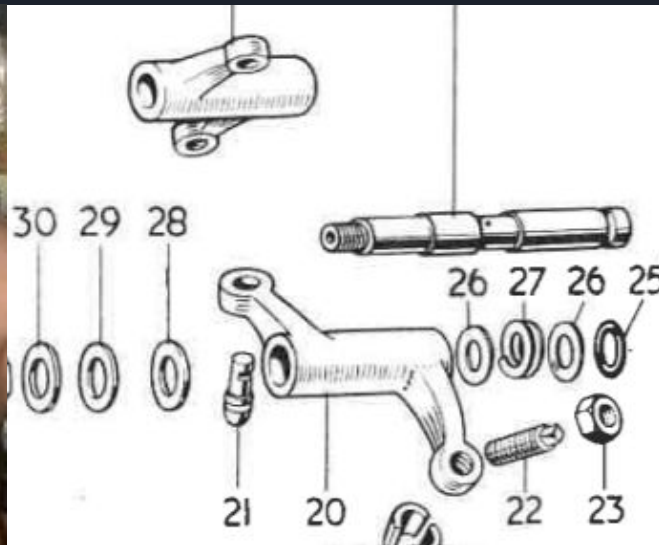
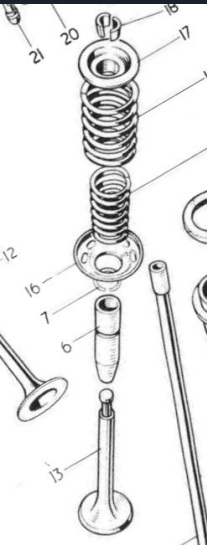
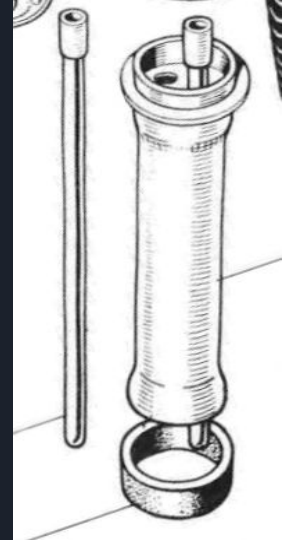

Springs and Rocker Arms

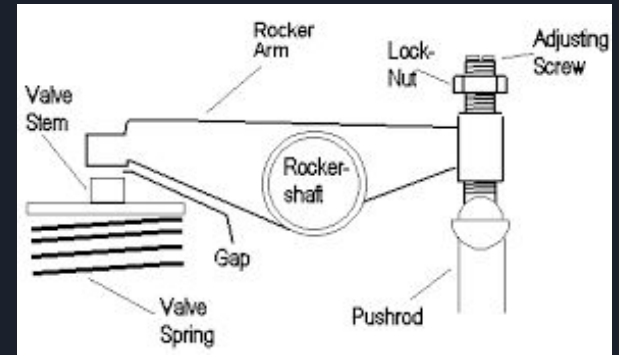

What do they do?

- The springs and rocker arms are pushed by the pushrods and allow for the opening and closing of the valves.
- Again, as one pushrod pressurizes one side, that rocker arm is pressed downward, resulting in the opening of either of the exhaust or intake valves.

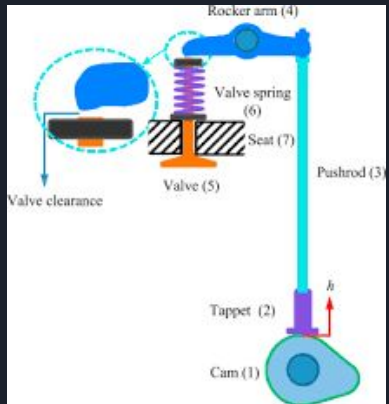

What did we do?

- There are two springs for each side and each spring runs counterclockwise to the other so it is vital to keep track of which spring is which when putting it all back together.
- We used a special tool to compress the springs to insert them.
- In order to keep the rocker arms in place, a spring washer and 3 regular washers are inserted next to it. This makes it especially challenging to put together and take apart.
- Finally we set the lash on both sides using the feeler gages.

The Pushrods



What do they do?

- The Pushrods are located on the back of the engine, above the cylinder.
- They move up and down as the engine does and as one moves up, the other moves down.
- As each makes their successive upward movement, they open the valve. Then as they move down they close the valve.
- The pushrods are free floating in their positioning, allowing for some bend and some leeway on the rods.
- The pushrods are made out of a steel alloy that allows them to be pliable, yet sturdy.

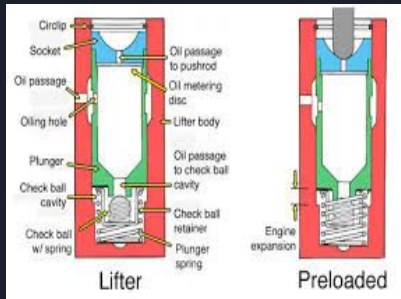

What did we do?

- We placed the push rods in their free floating positions.
- It takes a while since nothing is holding the pushrods in, so you have to make sure to go slowly and be sure that each pushrod is successfully in its correct position.