



This is a digital copy of a book that was preserved for generations on library shelves before it was carefully scanned by Google as part of a project to make the world's books discoverable online.

It has survived long enough for the copyright to expire and the book to enter the public domain. A public domain book is one that was never subject to copyright or whose legal copyright term has expired. Whether a book is in the public domain may vary country to country. Public domain books are our gateways to the past, representing a wealth of history, culture and knowledge that's often difficult to discover.

Marks, notations and other marginalia present in the original volume will appear in this file - a reminder of this book's long journey from the publisher to a library and finally to you.

Usage guidelines

Google is proud to partner with libraries to digitize public domain materials and make them widely accessible. Public domain books belong to the public and we are merely their custodians. Nevertheless, this work is expensive, so in order to keep providing this resource, we have taken steps to prevent abuse by commercial parties, including placing technical restrictions on automated querying.

We also ask that you:

- + *Make non-commercial use of the files* We designed Google Book Search for use by individuals, and we request that you use these files for personal, non-commercial purposes.
- + *Refrain from automated querying* Do not send automated queries of any sort to Google's system: If you are conducting research on machine translation, optical character recognition or other areas where access to a large amount of text is helpful, please contact us. We encourage the use of public domain materials for these purposes and may be able to help.
- + *Maintain attribution* The Google "watermark" you see on each file is essential for informing people about this project and helping them find additional materials through Google Book Search. Please do not remove it.
- + *Keep it legal* Whatever your use, remember that you are responsible for ensuring that what you are doing is legal. Do not assume that just because we believe a book is in the public domain for users in the United States, that the work is also in the public domain for users in other countries. Whether a book is still in copyright varies from country to country, and we can't offer guidance on whether any specific use of any specific book is allowed. Please do not assume that a book's appearance in Google Book Search means it can be used in any manner anywhere in the world. Copyright infringement liability can be quite severe.

About Google Book Search

Google's mission is to organize the world's information and to make it universally accessible and useful. Google Book Search helps readers discover the world's books while helping authors and publishers reach new audiences. You can search through the full text of this book on the web at <http://books.google.com/>

Practical features of telephone work

A. E. Dobbs

To

8



55
2x

TRANSFERRED
TO
HARVARD COLLEGE
LIBRARY

HARVARD
CO-OPERATIVE
SOCIETY.

°
PRACTICAL FEATURES
OF
TELEPHONE WORK.

BY A. E. DOBBS.

=

NEW YORK.
THE ELECTRICAL ENGINEER,
1899.

Eng 4288.99.5

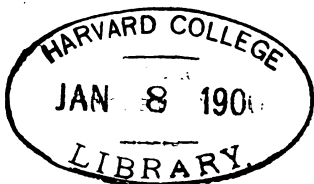

Farrar fund
90.13 342
 12

Entered according to Act of Congress in the year 1898, by
THE ELECTRICAL ENGINEER
in the office of the Librarian of Congress at Washington.

JUN 22 1917
LIBRARY

PREFACE.

The hints and suggestions contained in this book are the result of an experience covering fourteen years of active work, and while not as complete in all respects as the author could wish, yet he cannot help but feel that they will be useful to many who are just entering the telephone field.

Many of us have learned a great deal about the telephone business during the last four years that we did not know before. In the old days we had simply to take the apparatus designed and constructed by the parent company, and if it did not work, simply send it back. Competition has developed a new profession, namely, telephone engineering. The opening up of competition has also flooded the market with all kinds and styles of instruments, and those of us who thought we had mastered the art, found out that there was yet a great deal to learn. Besides, competition has now made the public exacting and discriminating, and nothing but the best will do, and the old days of grounded circuits and inefficient instruments are past; but, such is progress.

Chicago, Ill., January 1, 1899.

CONTENTS

CHAPTER I.—Pitfalls in Starting.—Poor Versus Good Work.....	7
CHAPTER II.—Starting the New Exchange.—Wire.—Aluminum Conductors.—Weatherproof Wire	14
CHAPTER III.—Country and Toll Lines	19
CHAPTER IV.—Exchange Lines and Circuits	28
CHAPTER V.—Size of the Return Wire	33
CHAPTER VI.—Locating Lines, Poles, Insulators, Etc.—Poles.—Insulators	38
CHAPTER VII.—Guys, Braces, Etc.....	43
CHAPTER VIII.—Corner and Junction Poles, Etc.—Guys.—How to Cross-Connect on Terminal Poles, Etc.—Tree Trimming	47
CHAPTER IX.—Cables	55
CHAPTER X.—Underground Conduits	62
CHAPTER XI.—Manholes.—Remarks on Electrolysis	66
CHAPTER XII.—Cable Terminals.—Counting Terminals, Etc.—Fuses and Lightning Arresters	74
CHAPTER XIII.—Selection of Instruments	84
CHAPTER XIV.—The Transmitter	89
CHAPTER XV.—The Induction Coil.—A Primary Lesson.....	93
CHAPTER XVI.—The Receiver.—Instrument Specifications; Wiring, Miscellaneous, Transmitters	99
CHAPTER XVII.—Instrument and Line Troubles.—Other Items....	104
CHAPTER XVIII.—Switchboards.—Batteries.—Central Battery Systems.—Repeating Coils.—Cross-Connecting Boards	110

CONTENTS.—Continued.

CHAPTER XIX.—Hints on Exchange Management	122
APPENDIX.—Wire Tables and Formulae.—Specific Inductive Capacities.—Properties of Copper Wire.—Bi-Metallic Wire.—Properties of Galvanized Iron and Steel Wire.—Aluminum Wires.—Properties of Aluminum Wire.—Supporting Capacity of Galvanized Strands.—Spans in Feet.—Weights of 1,000 Feet of Cable in Pounds	129

CHAPTER I.

PITFALLS IN STARTING.

THE rapid growth of independent telephone companies in the past two or three years has led to numerous and costly experiences on the part of some of their owners, many of whom having spent their lives in other pursuits, and having but vague and uncertain ideas on the subject of telephone construction and management, frequently acquire their knowledge at a price that would build a plant of twice the capacity of the ones they now possess. Many exchanges are equipped without regard to future, or even present needs, an increase of business necessitating a partial or entire rebuilding of the plant, and rebuilding is costly.

As a general thing the building of a new exchange proceeds something after this fashion: A canvass of the town is made to secure the necessary number of subscribers, and sell stock. It is successful. When the capital has been secured, the question comes up as to how the plant is to be built. Most of the men who furnish the capital know nothing of the business. They often send a committee off on a junket to visit one or two exchanges built by people as ignorant as themselves, and said committee-men come back with the idea that they know how an exchange should be built. An experienced concern would employ a competent engineer to make plans and estimates and superintend the construction of the work, but a new and inexperienced company with a calm confidence born of ignorance, in nine cases out of ten regard this as a useless expenditure, because there are any number of contractors willing to furnish them all the plans they want free of cost; and the idea is firmly rooted in their

minds that the contractor will do the work much cheaper and better than they can do it themselves and in this they are partly right if present needs only are considered. Remember, however, the contractor must have his profits; he has to live. A number of contractors bidding against each other will offer to put in a certain number of telephones for a certain price, an amount which will probably be less than an engineer's estimates, and lower than really good work at a reasonable profit demands. Now, the successful contractor may be a man who has followed railroad work, or cellar excavations, or electric railroad work, but even a telephone contractor with an ordinary conscience will not do any more work than the plans call for; especially if sharp competition has cut the price down to the last notch.

In many cases, too, the work lacks considerable of being finished when the contractor leaves it, and a force of men has to be kept for several weeks, or even months, to straighten up after him. Then, too, there may be cross-talk or switchboard trouble, and friction between the different departments results, for the outside contractor will lay the blame on the switchboard and instruments, while the switchboard contractor will lay it to the cables, and construction work, until the company wearies of this condition of affairs and takes over the unsatisfactory work to get rid of further trouble, and worries along as best it can with what is left. Contractors are not naturally more dishonest than other people, but they are human, and often doing business with people who don't know what they want. If work must be left by contract have a full set of specifications. Require the contractor to furnish wires, instruments and switchboard. Do not interfere with him as long as his work is up to the requirements of the plans, and hold him responsible for results.

But a long experience and observation have convinced the writer that, with competent superintendence, new companies can save money by doing the work themselves.

Well, the exchange starts out in business and if fairly well managed the lower rental charged increases the demand for

telephones beyond all expectations, and the plant being totally inadequate to the demand upon it soon has to be practically rebuilt at a cost considerably higher than would have put in the entire plant in the first place. If not rebuilt, poles, lines and switchboard being overcrowded, poor service, constant interruptions and repairs, and in some cases bankruptcy, are the result. I know of two or three exchanges that have been almost entirely rebuilt three times in the last four years.

Nor can the original contractor be blamed for this state of affairs. It is not his place to tell owners what they should do, or what they should not do. Even if his advice was offered, he would probably be suspected of some ulterior motive, and his advice taken like dreams, by contraries. It might be, as sometimes happens, that he is himself a stockholder in which case he probably would do as well as he knew how, but it does not always follow that he knows how. Almost any contractor, however, prefers to get a reputation for first-class work, but if the owners cannot be made to understand what good work requires, he cannot be blamed for carrying out the plans or rather lack of plans, furnished him, and I even know of first-class construction men who have accepted plans under protest and put in work which they knew was inadequate. No real estate man would put up a building without consulting an architect, but a telephone plant which requires as much or more real skill for its construction and operation is often put in without plans or system.

POOR VERSUS GOOD WORK.

Poor work in a telephone plant shows up worse than in almost any other kind of electrical construction; for where other circuits are numbered by a half a dozen, or even a score, of wires, telephone circuits are numbered by hundreds. There is not, I will venture to say, a power, or lighting pole line in the country carrying ten arms, and the only telegraph line I know of having anything like this capacity extends only a short distance from a Jersey City office. Yet in telephone work, ten or more arms on a pole is so common as to excite no comment

whatever. Poles that will do for electric light and power or telegraph work, are of little use on such lines as these, and while it is true that arms and wires are lighter, yet the strain on the wires and poles is considerably greater in the aggregate.

Yet in contract work we often find poles with 4-inch tops carrying from 25 to 50 wires: and a badly buckled and disreputable looking line is the result.

In one plant of nearly 1,000 subscribers, the contractor put all his lightest poles on corners, perhaps under the impression that because two corner poles were close together, they did not need to be so heavy. Unanchored stubs were put down in a yielding clay soil to hold guys for corner and terminal poles carrying from one to two hundred wires. Junction poles were cross-armed in such a way, that the crossing wires became veritable crows' nests, making it almost impossible for a man to get to the top. Poles crossing other wires were not tall enough, and stringing wires along this line involved the company in constant trouble with others.

Of course this plant had to be rebuilt in parts, and it was so badly mismanaged from the start, that many a contractor would be glad to build a better one at half its cost.

Nothing will drive away customers so quickly as a slouchy and bedraggled looking line, especially if the "old" company has been doing new work around the same town, to furnish a standard for comparison; for whatever may have been the faults of the old company in the past, its present work is done upon knowledge gained by 20 years' experience, and is of the most thorough and substantial character. People have the same prejudice against shabby looking work, that they have against a shabbily dressed man; and the only way to convince them that the "new company" has come to stay is to make the new work equal or superior to that of the older company.

I know of several exchanges that have almost doubled their subscription lists by rebuilding in the proper manner, and while rebuilding is expensive, because the work drags, for everything

must be kept working, yet in many cases the added business has made it a profitable undertaking.

A man who engages to superintend the building of an exchange should be familiar with inside as well as outside work for often we will find exchanges equipped with good instruments, and poor outside work, and vice versa. Sometimes a contracting company makes a specialty of switchboards and will sublet the contracts for instruments and outside work. In many cases there is a disposition on the part of managers to look out for bargain-counter instruments, though a brief experience is generally sufficient to convince them of this error. Others will try every make of instrument offered them, and get loaded up with all kinds, shapes and sizes, and so many different ways of wiring, that the hapless instrument man is driven to drink or worried into an early grave. The service carried on between bridged telephones and series telephones, high resistance and low resistance coils; bell magnets in series, shunted and cut-out; to say nothing of the different makes of transmitters and quantities of battery, becomes anything but uniform or desirable. But the men to be pitied are those who are loaded up with instruments purchased two or three years ago. It seems hard to have to throw away instruments that have only just begun to pay dividends, but if you are met by sharp opposition it will have to be done. Old instruments can often be worked off on small villages or private lines where they are looking for bargains and where the service is not exacting. Some managers desiring to get the best of everything will erect 40 foot poles where 25's would do just as well, buy heavy copper wire where No. 14 iron would answer every purpose, five cent insulators when those costing two cents would be amply sufficient, and in many other ways incur expense without regard to circumstances. That is simply a waste of money not justified by any prospective earnings; but to crown all, we sometimes see this material put up in a very inferior manner. If readers think this censorious or an overdrawn picture, a trip through the country will convince them that it is short of the

actual facts. Of course in a discussion of this kind, names and places cannot be given, but two illustrations of working toll lines will suffice.

Fig. 1. The 1,000 ohm bell could not call "central" or be called from there. After some spirited correspondence with the manufacturer of one of the instruments, a 1,000 ohm bell in place of the one marked 80 ohms remedied the trouble. It does seem though that a manager who had the faintest kind of an idea of telephone work would know better than this.

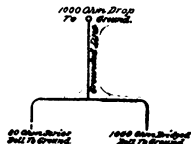

Fig. 1.

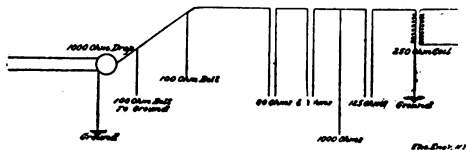

Fig. 2.

Fig. 2. This is a diagram of a toll line in use not a thousand miles from Lake Erie, and the more it is studied the worse it appears, and yet these people actually expect to compete with the "old line" company for business in this section. It seems to me that the Independent Telephone Association should draw up a standard set of specifications for toll line work right away.

In contrast I submit extracts from a letter of a manager of four years' experience which tells its own story. "We have put in one of the new — — — switchboards. We are also buying the — — — which I think is the best transmitter on the market. * * * We expect to build all our long lines full metallic and will use nothing but the best of everything. If the — — — telephone is the best we can get, that is the one we want and no other, unless we can find a better one. I am all the time looking for improvements, and want this plant as perfect as the experience I have, and what I can buy of others, can make it." This manager will have to throw away quite a number of old instruments, but he has learned his lesson.

Before putting in your plant, employ a competent superintendent, one who has had practical experience in building, or managing exchanges. Give him carte blanche in regard to details; pay him salary enough to make it worth his while to devote all his time to the work, and have all your plans and estimates made before you start. Then, if you decide to let the work by contract, you will have something tangible for contractors to bid upon, and you will be surprised at the uniformity of the bids and obtain a high standard of work.

CHAPTER II.

STARTING THE NEW EXCHANGE.

IN beginning the work, the "new company" will have one advantage, viz., the support of the people, provided they can be convinced that the newcomer means business. Rightly or wrongly there is considerable prejudice against the older company, and most communities would welcome competition; for the old theory that the telephone business is a natural monopoly, has no more foundation in fact than in regard to railroading, telegraphy or electric lighting, and an active solicitor will not only secure many of the old company's subscribers, but will add a host of others who could not be reached at old-time prices. Some business men will, of course, regard two telephones as a nuisance, but their attention must be called to the fact that they can reach about twice the number of subscribers at the same price they formerly paid for one instrument, and that competition insures better service, and to a certain extent a duplicate service, in case of trouble on one or the other lines.

Another point worth considering is this: Many parties will desire to retain both the old and new telephones. In this case it is an advantage and an accommodation to so arrange the numbers that business men in advertising do not have to use two sets of numbers. In other words, give them the same number they already have.

But it will not do to forget that the old company will meet the cut rates; that it has, or will have, first-class equipment, and men who know how to handle it; that it has, or will have, first-class instruments and long-distance connections—this latter being a very distinct advantage, until the new toll lines can be built—and while people may put up with indifferent service for two or three years, for the sake of having competition,

the one giving the lowest rates and the best service will finally secure the bulk of the business.

Scattered throughout the country are many towns that will support exchanges of from 50 to 500 subscribers, and it is to these we will first turn our attention; it is exchanges of this size that are most in need of advice, as larger ones generally make it a point to secure fairly good engineering talent. First secure a superintendent, or foreman, who understands his business and give him entire support as long as he is worthy, and be sure that he is broad-minded enough to employ good men to do the work. Line and exchange work is an art that cannot be learned in a week. I know of one exchange that had a very costly experience. Owing to the narrow-minded jealousy of the superintendent, the work was done by green men; so much so that it became pretty well understood that a good lineman could not hold a position there. The owners however found him out and let him go eventually, since when they have spent a great deal of money rebuilding, that might have been saved.

WIRE.

In towns of this size the lines will not average over, perhaps, $\frac{3}{4}$ of a mile in length, and well galvanized steel or iron wire will answer every purpose. In New York and the New England States, wire the size of No. 12 B. W. G. should be used—though many companies use No. 14. In States not visited by severe storms, No. 14 answers every purpose.

If I remember rightly, the old Western Union test of galvanized wire was to plunge the end into strong muriatic acid four times, withdraw it quickly, and wipe it off each time. If blackened after the fourth plunge it was not considered satisfactory, but if the zinc coating still remained bright, the wire was passed. This test, however, is a severe one, and was probably adopted because the W. U. wires generally follow railroad lines, where smoke and steam are hard on them. Good, ordinary No. 14 steel wire will stand three plunges, but not always the fourth. If it will not stand three plunges, do not buy it at any price.

Wire bought from firms who make and advertise telephone wires, will generally stand this test. Still, as it only takes five cents' worth of muriatic acid to make this trial, the buyer does not have to take anybody's word as to the quality.

Another test more frequently made is the following: "The wire to be plunged into a saturated solution of sulphate of copper and permitted to remain one minute and then wiped clean. This process to be performed four times. If the wire appears black after the fourth immersion it shows that the zinc has not all been removed, but if it has a copper color the iron is exposed, showing that the zinc is too thin." The reader can take his choice as both are good.

Now, in advising the use of iron wire for grounded, or common return lines, we will, no doubt, run counter to some of our young friends who will ask: "Is not copper a better conductor than iron?" "Does it not possess less self-induction?" "Will it not last longer?" "If it is the best, why not use the best?"

Stop a minute, and let us do a little thinking. Iron or steel wire, sizes No. 14 and No. 12, B. W. G., can be bought at from \$3 to \$6 per mile, while No. 12 B. & S. copper, which is certainly small enough, will cost about \$15; quite an item in a bill for several hundred miles. Then while iron wire requires only 33 poles to the mile, copper will need about 40; another little item worth considering. Iron again, does not require such care in handling, so that the men can make better time putting it up. It is true that its self-induction is greater than that of copper, but with the apparatus in common use the difference cannot be distinguished up to five or six miles. It is well known that induction coils are made to transmit clearly over from 2,000 to 4,000 ohms of line resistance, and it requires no great mathematical ability to discover that 50 or 100 ohms difference in resistance will make no difference in the volume of sound perceptible to the average ear. Then again in a common return system, the resistance of the iron wire is an advantage in allowing a smaller return wire to be used.

Iron wire wears out; so does copper. To be sure, copper can

be sold for junk, and it is also true that it is frequently stolen. Iron wire will last five or six years and can be renewed at any time; besides, conditions will change; for it often happens that pole lines, expected to carry only a few wires, become loaded down, and vice versa. Then, at the end of five or six years, when most of the wires and some of the poles need renewal, the managers will have had experience enough to deal with conditions as they then exist.

Since the use of iron wire does not necessitate poor work, is a great deal cheaper, and since except for very long lines it is practically just as good, why not use it? There is a time when a cheap line material will answer every purpose; as there are conditions that require the best of everything. Therefore save money on wire and high priced insulators, and put it into some other part of the plant.

Of course there are systems that require copper wire and metallic circuits in exchange work, but these are special systems, and they require special treatment. Sometimes, however, it is deemed advantageous to call the attention of the public to the fact that iron wire has been discarded. Even in that case three or four dollars a mile can be saved, by using the Roebings' bi-metallic wire. Theoretically it seems better than either copper or iron alone, for grounded, or common return systems. Though it has only about 67 per cent. of the conductivity of copper, the manufacturers claim that for grounded circuits it gives as good results as copper, section for section, which may be due to the fact that alternating currents of high periodicity travel on the surface, and do not penetrate deeply into the metal at their first impulse, and it is possible that the self-induction and resistance of the steel core confines the current more largely to the surface, preventing what is called the skin effect, in retarding transmission. It stands the weather as well as hard drawn copper, and the steel core gives added strength, therefore requiring fewer poles. There are local telephone companies using a considerable quantity of it.

ALUMINUM CONDUCTORS.

I learn that for electrical conductors the Pittsburg Reduction Co. are prepared to put aluminum wire on the market at a price that will make it cheaper than copper, section for section. It is very light, a mile of No. 12 B. & S. weighing only 32 pounds. It will stand the elements as well as copper, and has the same freedom from self and earth induction, and as a conductor is far superior to iron, its conductivity, bulk for bulk, being above five times greater.

As compared with copper, its conductivity equals about 63 per cent. or, bulk for bulk, it would take about two sizes larger by B. & S. gauge to attain the same conductivity; thus, a No. 12 aluminum is about the same as No. 14 copper, No. 10 aluminum to No. 12 copper, and so on down.

While it cannot displace copper as a conductor, there are many places where its lower cost, freedom from self-induction and lightness will make it desirable.

WEATHERPROOF WIRE.

Another wire that should be kept around an exchange is double or triple-braided, weatherproof, either No. 14 or No. 16 BB iron. There are many places where it can be used to advantage, for example, in running through trees, in making house drops, crossing trolley lines, etc. Trolley lines especially should never be crossed with bare wire unless so thoroughly guarded that an accident is impossible.

Some of our readers, perhaps, have never seen men shocked into insensibility and laid up with burns that reached to the bone, or seen switchboards and instruments burned out. Those who have do not need this advice.

CHAPTER III

COUNTRY AND TOLL LINES.

LINES more than twelve miles in length should be metallic circuits, and even the shorter lines will give better results if metallic. But sometimes the revenues will not justify the expense of stringing two wires, but this is a matter that must be governed by circumstances. There are parts of the country where grounded lines will work fairly well, even as far as a hundred miles; but a trolley line within five miles will affect them, and one within two miles will make metallic circuits necessary for satisfactory service, especially if the two run parallel. Wire used in this class of work should not be smaller than No. 12 B.

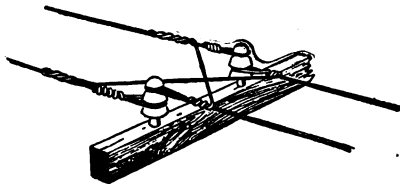

Fig. 3.



Fig. 4.

W. G. iron, or No. 12 B. & S. copper. For longer lines No. 9 iron is good up to fifty miles, though No. 12 copper is better. The size of the conductors should be such that the resistance of the two longest toll lines coupled together will not exceed 4,000 ohms. But the lines should not be worked to the limit of high-

est resistance, as extensions must be counted on, and it is well to have enough. If iron wire is used, place poles at the rate of 33 to the mile—though we sometimes see as few as 25—if copper, 40 to the mile.

If the wires are on arms, have the pins twelve inches apart. But if the line does not carry more than four wires, there is no real need of using arms, for brackets are cheaper, and if well spaced and the wires properly pulled up, will look just as well, and can generally be kept clear of trees much easier. If, however, an arm becomes necessary, use only ten-pin arms. If the poles are set 40 to the mile and well braced and guyed and the wires pulled tight, pins ten inches apart will do; but be sure

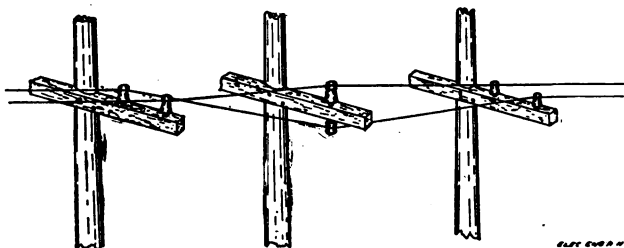

Fig. 5.

the arm is heavy enough. It should be at least three inches in thickness and a full four inches in width.

Of course, all metallic circuits have to be transposed at regular intervals. There are various ways of transposing circuits. One of the most common is shown in Fig. 3, which explains itself. Another method, known as the running transposition, requires a duplex pin (Fig. 4). The change is made by crossing from one pin to the bottom of the duplex pin on the next arm, and at the next pole both wires (Fig. 5) have changed places. This system saves making joints, but is troublesome.

The necessity for proper transposition of long metallic circuits is well known, but just how to do it has caused a great deal of hard thinking and it sometimes keeps the best of telephone men

guessing where they are at. While it is possible to map out a plan of transposition before the line is built, still, changes are often necessary and a brief study of the principles involved will help in understanding the matter. It is pretty well understood that two or more wires running side by side for a long distance will have an effect upon each other when traversed by an alter-



Fig. 6.

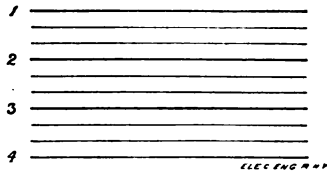

Fig. 8.

nating current and that the induced current in its neighbor has a direction opposite its own.

If we pass a current through a wire, a cross-section of which is shown in Fig. 6, and test it with a dipping needle, we find lines of force radiating from it in all directions, as shown by the dotted lines. We also see that another closed circuit nearby, at say the point A, will attract the larger number of them to one side and the nearer these two circuits are together the greater the number of lines attracted, and that a magnet or piece of iron at A will deflect still more of them.

Turning to Fig. 7, we have shown two circuits running side

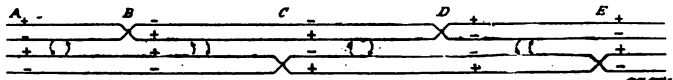

Fig. 7.

by side and both in use. Supposing that both are connected to the boards the same way—as they are likely to be—and that they are also connected to the same side of the battery, we have then the +, or positive side of our circuit, on the first wire, and the —, or negative, on the second. By following the direction of the

arrows between the first and second circuits we find an exchange of the magnetic lines turning in the same direction as the current on the next wire between the points A and B. Now, if kept up, this would induce a condition of unbalance, and even if it did not throw in cross talk would make the lines noisy.

If we now transpose one of the circuits at B, we still find an

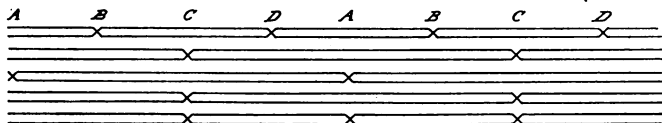

Fig. 7a.

exchange of the lines of force, but this time they are opposing, and if equal, will neutralize each other. If both circuits were transposed at B the effect would be the same as it would be from A to B, only the induction would come from opposite sides; but by transposing one circuit at B and another at C it will be seen that half the time the currents pull together and half the time oppose each other, so that if regularly transposed the effect is nil. Circuits could not be arranged to oppose one another all the time because the current is changed with the direction of the conversation, but even if it were possible to keep them opposed all the time, their effects would be to retard each other, increase



Fig. 9.

the resistance of the line and throw it out of balance. Then, too, there are the induction from the earth and other electric circuits to be considered, so that even if their mutual induction were done away with or suppressed it would still be necessary to turn the circuit over, in order to present different sides to the source of the disturbance. Then there is the mutual induction between the two sides of the circuit itself, and were it not for an occasional transposition that, of itself, would upset the balance. The

more the lines of force or induction can be induced to stray to its mate, however, the less there is to stray away elsewhere, and Fig. 9 shows the design of an arm intended to keep the two sides of the circuit as close together as possible, the pairs being only six inches apart, while the distance to the next circuit is fourteen inches. As the longest line is in the centre, there is no need of having the wires so close, and they cannot be, on account of the pole space. But the looks of this arm will probably prevent its adoption, and, besides when wires are only six inches apart, they have to be pulled up taut and even, to keep clear of trouble.

This brings up an hypothesis held by the writer for some time, which is, that a circuit partly of iron, or steel, and partly of copper, or aluminum, will give better results than one wholly of copper. In Fig. 8, let us suppose that of the circuits 1 and 2 the two heavy lines, representing iron wire, are placed on the outside, while the two centre ones are copper. Does it not seem reasonable to suppose that these iron wires would, to a certain extent, act as a shield against outside influences? Also that the magnetic quality of the iron would draw the lines of induction from its mate, instead of permitting them to stray to outside sources? It is pretty well known that a certain amount of self-induction is a good thing with which to oppose the static charge, for, while the magnetic induction travels with the current, the static charge opposes it, and by transposing at regular intervals the resistance of the circuit is kept in perfect balance.

Between the two towns of Kent and Ravenna, O., there is such a line, one being No. 12 steel and the other No. 12 copper. The line is as quiet as could be desired, though, as it is only seven miles in length, it cannot be regarded as a fair test, especially as lines in that section from 30 to 50 miles in length are commonly built with No. 9 iron, or steel, and the service on most of them leaves nothing to be desired.

In quiet country sections, lines are transposed at intervals of a mile, but near telegraph or trolley lines this has to be increased. The only way to test it is to go on the line with a telephone and keep cutting in transpositions till the line gets

to be quiet. In some places it may be necessary to transpose every five or six poles.

In Fig. 7a is a map of transpositions similar to that used by the American Bell Company in their long-distance work on ten-pin arms. The longer lines will not require such frequent changes as the shorter ones. Divide the line into sections of a quarter of a mile each, as shown by the letters A, B, C, D. Transpose the middle line on A and for the lines adjacent half way between, say one at C and the other at D, and, as the outside lines will probably be shorter ones, transpose twice as often, say at A, C and B, D, making these come half a mile apart. Then as each line is built, test it with a telephone and if noisy try to locate the disturbance. It may be a trolley line at one end. That being the case, cut in a few more changes at that end. When more than one office is connected to a toll line—and there generally is—bridging bells in multiple are the only kind that can be relied upon, for a 1,000-ohm bell, on account of its high resistance and high self-induction, will permit of very little leak from the rapidly alternating currents (100 to 2,000 per second) found in telephonic conversation. In a transformer for electric lighting very little current is lost when there is no load on, because the self-induction of the core gives back to the line 95 per cent. of the current put into it, and it is probable that a 1,000-ohm bell will do equally as well as ten or twelve instruments sometimes put on a line. Never use series telephones for this kind of work, as the self-induction of an 80-ohm bell will increase its resistance many times beyond 80 ohms, unless, as is sometimes done, a non-inductive resistance is shunted around the ringer coils.

In some cases there is a disposition to overload country toll lines by putting too many stations on a circuit; and cases have been heard of where even 20 or 30 instruments have been connected to line. There are two troubles with this method; one is that too many people will want to use the line at the same time, and another is that the resistance between the two sides of the circuit becomes so low that ringing all the bells becomes a diffi-

cult matter; but even where the ringing can be successfully accomplished, the loss of current in conversation very materially reduces the volume of sound.

Let us suppose that we have a line 100 miles long, with 20 instruments bridged in, with stations at an average of five miles apart, and bridged bells of 2,000 ohms each. It will be seen that the resistance between the two sides of the circuit would be 2,000 divided by 20 equals 100 ohms. If now No. 10 copper wire is used, there is a line resistance a trifle over 1,000 ohms to the most distant station. It is true that the high self-induction of the ringers will increase the resistance to telephonic currents many times 100 ohms, yet it is fair to assume that at least half the talking current will escape, especially when, as is often the case, German silver wire is used in winding the ringer coils. In order to overcome this the induction coils are wound very low, sometimes as low as 10 ohms, which may expose the user to patent litigation if the Carty patent is worth anything at all.

Where there are so many telephones to be placed on a line, it would be better to run a separate wire for signaling, as done by the Victor Telephone Company, leaving the talking circuit open, except when it is in actual use, as is shown in Fig. 10. In this case the lines 1 and 2 constitute the talking circuit, which is open except when one or more of the telephones are in use. Line No. 3 is the signaling circuit and bridged into one side of the talking circuit; or the bells may be cut in in series, and connected to the talking circuit only at the ends, though it would also be better to have one or two bridged in on the line at regular intervals. Or, if a third wire is used, it could be grounded at both ends and thus kept clear of the talking circuit altogether, which would probably be a better way yet, the line being cut in by a special 4-point switch, which would cut off the ground altogether when the receiver is off the hook.

Sometimes for comparatively short lines the third wire may be used as a common return for two circuits; but in this case the resistance and static capacity of the two sides should be equal, either by having the lines of equal length or by introduc-

ing an artificial resistance and condenser in the shorter one, as shown in Fig. 10a. This resistance might be inserted by using a smaller wire for the shorter line. Both lines should have the same number of telephones.

The advantages of these systems are that a circuit of No. 9 or 10 iron or steel wire may be made almost as efficient as a copper one and highly wound induction coils used to overcome the extra resistance, and with the latter system two parties could use the lines at the same time. Iron or steel wire will last from ten to twenty-five years in country districts, and by that time we may have something entirely different.

Again, as suggested before, telephones may be connected in

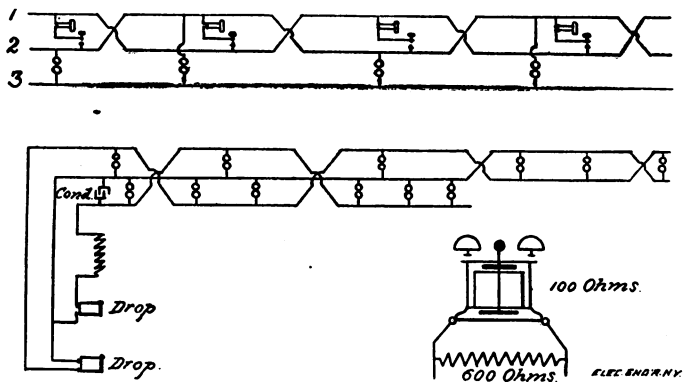

Figs. 10, 10a and 10b.

series by having a non-inductive resistance shunted around the coils, as shown in Fig. 10b. In this case the two sides of the circuit should be balanced by cutting in one instrument on each side. This plan is used by the Western Telephone Construction Company. The shunt should have a proportion of, say, 5 to 1.

A non-inductive shunt should contain no iron and there are several ways of doing this, either by winding a German silver coil on a wooden spool, in which the wire should be doubled upon itself the same as a galvanometer bridge coil, both ends

coming to the outside; or, 110 volt incandescent lamp would answer, the resistance of one lamp being approximately 220 ohms, three such lamps making a very efficient shunt. It might also do to use a telegraph relay in such a circuit, using the telephone battery to ring a bell in the local circuit.

CHAPTER IV.

EXCHANGE LINES AND CIRCUITS.

IN exchanges of less than 1,000 subscribers metallic circuits are not necessary, a common return answering every practical purpose.

In some small country towns, grounded lines will answer, but a return wire is generally preferable, for, with lines grounded to gas and water pipes and driven rods, the resistance of the "ground" and therefore of the line is a very uncertain quantity. Rods especially are a nuisance in this regard. The author remembers cases where telephones, even grounded in the bottom of a well, had their talking qualities improved 100 per cent. by being connected on a direct return to the office. Then there is no working time saved if, in the search for a good ground, the wireman has to bore through two or three partitions or through floors to the cellar, as is often the case.

Even where a water pipe, an ideal ground, can always be found, electrolysis will often be set up between the lead or iron of the pipe and the copper wire, for soldering such connections in private houses is not feasible, and such connections need more or less inspection, to say nothing of the fact that the ground wire running, as it does, through different rooms or through cellars, is often broken. It is almost as easy to drop two wires from a pole line as one, then put a single hole through the wall or window casing and the work is done, and the return service can always be relied upon. Of course, it is also well understood that where a trolley line exists a wire return is the only satisfactory one.

The proper place for the return wire is on a bracket below all the arms that the pole is ever likely to carry. For example, suppose that the line may have to carry six arms; by putting it below where the sixth would come the wires will not only be

well spread out in making house connections, but it will serve to protect the line against too close familiarity on the part of other companies and hold a clear right of way for these six arms against all comers. Still there are good construction men who insist upon putting it either at the top of the pole or on a bracket under the top arm. The objection to this is that it is always in the way and in making drops to buildings it is not so easy to keep the wires apart, and often necessitates the use of porcelain knobs on the arm, which is not desirable by any means.

The only reason ever heard given for having the wire at the top of the pole is that in neighborhoods where electric light and trolley wires abound it is necessary to keep the two sides of the circuit as close together as possible.

We fail to see that this reason is valid, for the wires on the poles are not free from trolley influence and the short leads to the house connections, if carefully insulated, cannot gather up a great deal of noise, and if the lead to the subscriber's premises is any great distance from the main pole line, the two wires will run side by side anyhow, and unless insulated wire is used they must be kept far enough apart to keep "clear."

In many towns it is best to use twin or duplex wire in connecting to the subscriber's premises, but even then it is as easy to catch the return wire on one part of the pole as another. Now, a word as to duplex wire.

This is the most convenient and sightly method of making connections from the pole to the house. Fig. 11 shows the style of duplex wire commonly used for this purpose, it being simply two insulated wires twisted together.

It is commonly of No. 16 iron or No. 14 copper. Duplex wires should have a braided covering on each separate wire, as plain rubber covered wire, often used for this purpose, means constant trouble, except, perhaps, in offices where it is not exposed to the weather and can be constantly inspected.

The style shown in Fig. 11 is used almost entirely by some telephone companies in making house connections, and is the

only kind to use in going through trees, but it frequently gets into trouble from the wires chafing each other and coming together.

Fig. 12 shows a form used with great success by the writer, and we have yet to find the first one chafed or burned through. The large wire (a) is simply a No. 14 iron wire, or No. 12 copper if preferred, double or triple braided weatherproof; the other (b) may be common No. 18 annunciator wire (though black weatherproof or rubber covered and braided No. 18 wire is preferable), wrapped lightly around the outside, at the rate of about one turn to the foot.

The heavy wire alone is fastened to the insulators and the ends of the smaller wire can be left long enough to reach to the

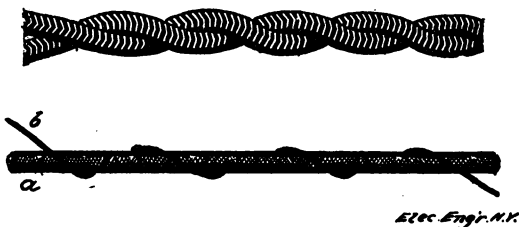

FIGS. 11 AND 12.

instrument without a joint and to reach the line wire at the other end, leaving that side of the line free from joints. Two men can make one of these in a few minutes. The advantage in using this latter form lies in the fact that the smaller wire, lying lightly outside the other, being drawn only tight enough to keep it from sagging, does not chafe or wear the insulation.

The Simplex Company of Boston advertised something like this some years ago, but with this difference, that the centre wire was copper while the outside one was steel. I am inclined to think that the steel wire on the outside, though theoretically better, would be more troublesome in practice, on account of chafing through, but having never seen the wire, of course, I can't say.

But to come back to the subject of the common return wire. This should generally be of copper, though sometimes it is desirable to use iron wire to stiffen the pole line, but where iron is used have nothing smaller than No. 8 for leads carrying not in excess of 20 wires, while for leads carrying not in excess of 35 wires two No. 8 or one No. 6 will do. If two iron wires are used keep them separate, distribute the load as near equally as possible on each, run them side by side and transpose every few poles, making a running transposition on brackets as shown in Fig. 5. In this way cross talk will be reduced to a minimum.

Note: If iron wire is used to stiffen the line extra heavy brackets will have to be used and at least one lag screw instead of nails to fasten them on. But, still, its superior conductivity and absence of self induction put copper away ahead of iron for this purpose.

All joints should be carefully made, and in order to reduce resistance to the lowest possible point, soldered. It is true that copper joints known as the "3-wire" splice show a very low resistance, being only from .004 to .012 of an ohm (see *Electrical Engineer*, November 18, 1897). But a little carelessness may increase this resistance and even one extra ohm may increase the cross talk very materially.

In soldering copper use a heavy iron or a blow torch with a small concentrated flame and solder only in the centre of the twist, and do not leave the heat on any longer than necessary, and do not heat outside the joint, as heat will soften and weaken the line. Thus a joint can be made that is electrically and mechanically perfect.

Soldering is not necessary in the drop from the lead to the subscriber, nor is it necessary to solder wire smaller than No. 10 B. & S. All copper lines should be made with what is known among linemen as the "3-wire" splice. This is made by splicing in an extra piece of wire, as shown in Fig. 13, after which it is finished the same as any other twist joint. This is much stronger and better than the ordinary telegraph splice.

In many cases where cables are used and fairly well insulated, the return is connected to the lead sheath, thus saving the length

of copper wire necessary to reach the office. This plan, however, is not to be recommended, as, unless the cable and span wire is well insulated, the system will be thrown out of balance. Of course, there is an opinion among many telephone men, and it seems reasonable at first thought, that it does not really matter whether a grounded return wire is insulated or not. But if the common return is regarded as part of a metallic circuit, it will be easily understood that a ground anywhere else than at the office, will throw the whole system out of balance. This balancing of a return system is a fine art and cannot receive too much

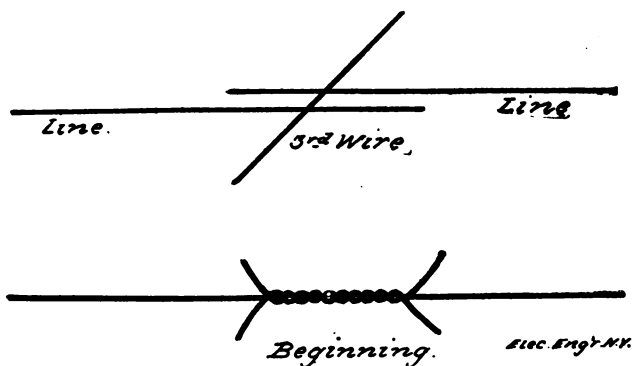

FIG. 13.

attention. It is also possible to have a wire too heavy as well as too light.

Some exchanges do not ground the common return at all, but keep it as well insulated as possible throughout. This is a good plan except for trouble with the static charge which is much worse on such a system; while a grounded system is troubled with greater induction. The insulated system can be cleared by means of a condenser. Never connect a subscriber from one lead to the return wire of another and do not connect the return wires together except at the office.

CHAPTER V.

SIZE OF THE RETURN WIRE.

IN regard to the size of the return wire, there is a wide diversity of practice even among the various Bell companies, who have perhaps greater uniformity of engineering practice than is possible among independent companies. In some places a No. 4 wire has been run out to serve 500 subscribers; in others, No. 0 is used for half that number. Some ground the wire at the office and various other places; some only at the office, which is better. Some don't put on any ground at all, better still; while others do not even bring the wire into the office at all, cutting it off at the pole outside and letting the talk come in over the other lines, which is not a very good way, though there may be circumstances that justify it.

One company puts its subscribers in groups of from 20 to 40, using a No. 10 wire for each group.¹

An acquaintance, unable to determine the question for himself, took a trip to a distant city to consult an eminent electrical engineer on the matter, and as a result of his advice strung six No. 6 copper wires to return the back talk of about 250 subscribers; a clear case of wasted copper, for one of these wires would have answered just as well. And the worst of it was that there was more cross talk in that exchange than in any other modern exchange I have ever seen, and he cannot be convinced to this day that the cross talk does not come from an insufficient amount of copper. Had he studied more about cable and switchboard work he would have had better success.

By the way, his city friend was a man who ranks high in his

¹As copper is nearly always sold by the Brown & Sharp gauge all copper wire will be given in this size; also, iron wire is generally sold by the English standard or Birmingham gauge (B. W. G.). The B. & S. gauge runs about two sizes larger for the same size of wire. Thus No. 10 copper is about the same size as No. 12 iron, while No. 12 copper matches No. 14 iron, etc.

profession, but he has spent all his life designing motors and superintending street railway installations, and can hardly be regarded as a telephone expert, even though he does frequently "get his name in the papers."

There is an impression among the new men in telephone work that a bulky return wire is necessary and if there is any cross talk, the wire, already larger than necessary, is reinforced, and—the cross talk is still with them.

The fault will generally be found in the switchboard or cables, and a return the size of a trolley feeder would not help matters. But more of this later.

Before going further let us do a little work in simple arithmetic. Let us take, for example, a lead of 100 subscribers and try to get at the resistance of the return:

The resistance of the drop, say.....	150 ohms
Resistance of bells	80 ohms
Resistance of average line, including capacity, etc....	70 ohms
	<hr/>
Total	300 ohms

This may be put down as the lowest average resistance of a line when not in use. Of course the resistance of drop and bells will vary over wide limits.

Of the 100 subscribers the occasions will be rare when more than six pairs of plugs (12 subscribers) are in use, but let us say seven pairs (or 14 subscribers).

On the lines in use we have:

Two induction coils of 250 ohms each	500 ohms
One ring off drop	100 ohms
Two receivers	150 ohms
Line resistance, including capacity, etc.....	100 ohms
	<hr/>
Total	850 ohms

One coil however by its self induction throws back on the line almost as much current as it receives, but the self induction of the other coil will raise its resistance, in almost the same ratio so that 500 ohms for the two coils is not far out of the way.

As will be seen by reference to Fig. 14, the subscribers on a common return system—or a grounded system for that matter—are all connected in multiple.

We have shown fourteen telephones connected to the exchange in actual use, the lead of 100 subscribers being for convenience's sake, represented in the form of a cable.

It will be seen that the current will not only come in on the return wire, but will distribute itself to every other wire in the system in proportion to its resistance. Now let us see:

Total return resistance of 14 lines in use = $850 \div 14 = 61$ ohms

Now, if the average subscriber's distance from the central office be three-quarters of a mile, a return wire that will balance the resistance of the 86 lines not in use should help us out all right.

By looking over a table of resistances for copper wire we find

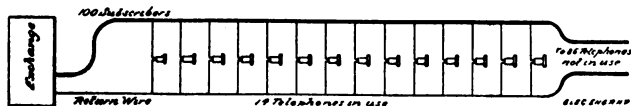

FIG. 14.

that No. 9 B. & S. has a resistance of a trifle over 4 ohms to the mile, therefore the resistance of three-fourths of a mile of this size would more than balance the conductivity of the lines.

Our return now therefore would be:

86 lines	3.5	ohms
Common return	3	ohms
Combined return and 86 lines.....	1.6 +	ohms

From this we will see that the relative conductivity of these 86 lines, and the common return, is 1.6 to 61 ohms, a proportion of 38 to 1.

The one part left for these 14 wires is divided up among the 13 other wires, or in other words, the 14 lines, if their resistance

is approximately the same, receive $\frac{1}{38 \times 14}$ or $\frac{1}{532}$ of the current.

We can therefore lay down the following rule for getting at the size of the common return:

1. Find the resistance of one line for the average distance from the exchange, including that of the drop and bell magnets.
2. Subtract from the total number of lines, the number of lines which may be in use at one time. (14 in 100 is a good number.)
3. Divide the resistance of one line by the number of lines so left, and select a wire, whose resistance to the centre of distribution will be equal to this quotient.

In order to have reliable service it is not generally advisable to use a copper wire smaller than No. 10 B. & S., except on leads having not more than 25 wires.

When wires on different leads are joined together, the wire towards the office end should be increased in proportion unless it is already sufficient to do the work, and when they are all joined together at the office pole a wire equal in cross section to all of them, brought to the switchboard or bus-bar.

In places where electric light and power induction is unusually severe, it may be necessary to divide the subscribers into groups of from 20 to 40 lines each, keeping the subscribers in each group as close together as possible, carrying the return from each group back to the office.

Where this is the case and two or more return wires run on the same pole, they should be kept as close together as possible and frequently transposed, or—this is merely an hypothesis of the writer—it might be well to run out one wire large enough to supply all the subscribers and have the return wire for the different groups kept separate, and connected to the main return on much the same principle as the feeder and main system in electric light wiring, Fig. 15, in which the main return wire should be heavy enough to leave but a small resistance between the different groups.

In some exchanges it is customary to ground the common return wire at the office, but I think that a better balance is preserved by not grounding. Still there are places where it is

very inconvenient to run two wires, and being able to run a ground is quite an advantage, for while conversation could be carried on through a repeating coil, the subscriber could not be called without adding complications to the switchboard wiring.

In making house connections use porcelain knobs instead of brackets, for brackets on the side of a house are always un-

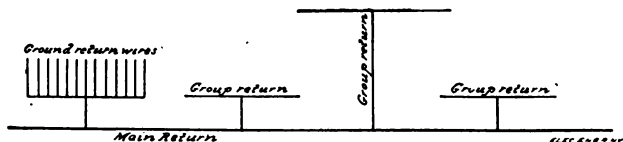

FIG. 15.

sightly, and well glazed porcelain affords insulation enough for all practical purposes, but do not cover the side of the house with them, for two or three are nearly always enough.

While on this subject we may as well say that wires from the pole to the house should not be drawn very tightly, as it is not often necessary, and a tight side wire will not only pull the pole out of line, but is apt to be a "hummer."

CHAPTER VI

LOCATING LINES, PILES, AND OTHERS ETC.

LAYING out trains and pile lines will often require a great deal of diplomacy as a good amount of purely capricious opposition will have to be met and overcome. People living in areas where there are already piers and in two pile lines are hardly to be blamed for not wanting to get another one. Some say there may be a few compelling oil companies occupying the areas in question and the same one is a single pile line. This scheme is practicable and would be less troublesome and expensive than the present cumbersome and unrigid methods. Meanwhile each company has to build its own pile line and the fact that the company has a franchise from the lower court is of some assistance does not give it the right or way if property owners object or are otherwise given any right what does not belong to them, but the fact that the company holds a franchise for all areas and they are given the right as a successful argument or hint. It will never be found that the fact that the company has a franchise from the lower court is of any help in the matter. The fact that the point is in question should be of some value only if some of these people may be able to show a great deal of influence or in regard to the company in some way and the new company will have to be prepared to meet all the opposition.

It is possible that the new company will have to meet some of the opposition of the old company. It is possible that the new company will have to meet some of the opposition of the old company. It is possible that the new company will have to meet some of the opposition of the old company.

tioning were met, nor paving to be done; no trees in the way worth mentioning, and no objections from property owners; while smaller and cheaper poles were used than would have been possible on the main street.

Again, by going into the alleys the company really covered three streets, so that after all the cost was no greater than to have covered the same territory from the main streets.

Never set a pole in front of a man's house or lot if it can be avoided. Choose the line between two lots, and much objection will be silenced. Poles intended to carry three or four arms should be planted as nearly as possible, 130 feet apart, as they will hold the wires in better shape, and avoid much trouble.

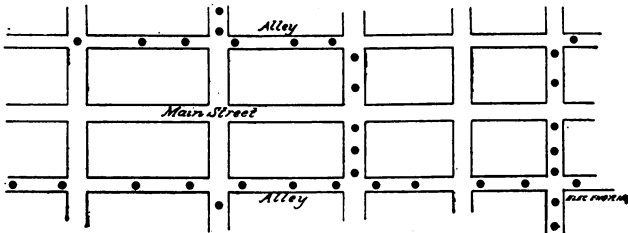

FIG. 16.

A very good plan used for local distribution at Albany, N. Y., in streets where shade-trees made a pole line an impossibility, was to stretch a No. 6 wire across the street from tree to tree, about 20 feet from the ground to which were tied from 10 to 30 porcelain knobs, at about 12 inches apart, over the centre of the street. The line wires were then drawn through the centre holes of the knobs, and distributed where needed. The span wires were from 100 to 125 feet apart.

POLES.

Cedar or chestnut poles are by all odds better than any others to be found in the Northern States, while in some sections spruce, yellow pine, or cypress are the only kind to be had at reasonable cost. In some parts of the country sawed poles are used a

great deal, but they do not last as long as the round timber. In some places poles can be procured nearby, in which case it is generally better to cut them in midwinter, for there is a tradition among farmers that they last longer than if cut at any other time, as the sap is then out.

If the plant is being built on a permanent basis, no poles smaller than six inches at the top should ever be used if possible to avoid it, and accept a six inch top only on condition that the pole is stocky and solid otherwise. We have known of contractors using poles as small as four inches at the top, but that does not make it good practice. The part of the pole that goes into the ground, should be treated in some way to prevent decay, either with tar, asphaltum or creosote. Even an oil paint is better than nothing at all. The ends especially should be saturated with it, to prevent the absorption of moisture. In some parts of the West they are put over a fire, or kerosene is poured over them and they are charred at the butts, which is said to double the life of them in the ground. Some companies boil both poles and arms in raw oil or creosote, putting them in a vat for this purpose, which should fill the pores pretty thoroughly, and improve the insulation as well.

Gains for the arms should not be cut more than an inch in depth, and should be soaked with paint before the arms are put on, thus preventing a great deal of dampness and decay at these spots. The top of the pole should also be well saturated with paint, which will prevent warping and splitting. The two top arms on chestnut or spruce poles should be secured by a bolt, for which a hole must be bored clear through both arm and pole, and the pressure relieved by a two inch washer, or better still a plate of 3-12 iron, two inches square. If lag screws are used they are liable to split the pole. Where lags are used on cedar, or green chestnut, they can be driven home, but in seasoned chestnut or other kinds of wood they had best be turned up the last inch with a wrench. Of course all 10-pin arms at least will be braced. The most common brace for this size is $22 \times 1\frac{1}{4} \times \frac{1}{8}$ or $\frac{3}{16}$. Standard 10-pin cross-

arms are of two sizes, known as the short and long arm; one most commonly used in exchange work being 8 feet 6 inches in length. Specifications as follows:

Dimensions	8 feet 6 inches × 3 inches × 4¼ inches.
Distance between two middle pins (centre).....	16 inches.
Distance between all other pins (centre).....	10 inches.
Distance of pins from each end (centre).....	3 inches.
Diameter of pins.....	1¼ inches.
Length of pin to shoulder (lower part).....	3⅞ to 4 inches.
Length of pin from shoulder to top.....	4⅞ to 4½ inches.
Total length of pin	8 inches.
Length of thread	2⅞ inches.
Number of threads to the inch.....	5
Depth of threads	⅓ inch.

Specifications for long arm:

Dimensions.....	10 feet × 4¼ inches × 3¼ inches.
Distance between centre pins	16 inches.
Distance between all other pins.....	12 inches.

Other details the same as for the short arm, except that sometimes the pins are 1½ inches instead of 1¼ inches, but we do not think this is necessary, if the pin is made according to the specification given above. Iron pins are being used a great deal. The best wooden pins are locust, with chestnut second, and oak third; this latter not having the lasting qualities of the first named. The best arms are made of yellow pine, or creosoted white pine. It is also advisable that pins should be well oiled.

INSULATORS.

For wire not heavier than No. 9, what is known as the pony is the cheapest form and as good as any for telephone work. One style of insulator has two grooves and this is often an advantage, for on corners the wire can be dropped down to the second groove, bringing the strain nearer the base of the pin, while on junction poles the tops can be lashed together, while the line pulls off from the lower groove, though a double glass with a skirt between the groove is better for this work.

The double groove glass also makes a very fair transposition glass as it will interpose about 1½ inches between the two wires

and while this does not afford the highest insulation between the wires, there is a growing impression among telephone men, that a slight leak at regular intervals is an advantage to the line rather than otherwise. On country lines it is perhaps advisable to use heavier glass—that known as the heavy pony being about the thing—because a country line is never inspected as long as it will work, and the light pony insulators break too easily, and are liable to remain broken for some time, without being observed.

CHAPTER VII.

GUYS, BRACES, ETC.

POLES on curves and corners need to be well guyed or braced, for if there is one thing which is more aggravating than any other, it is to have the wires continually getting slack, because the corners give way.

The proper method of guying is, however, the sticking point with some otherwise good construction men. Figs. 17, 18, 19, 20 and 21, show the various correct and incorrect methods of

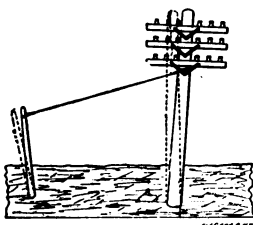

FIG. 17.

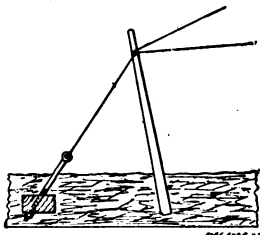

FIG. 18.

holding corner poles in place. In Fig. 17 we have a method of guying often seen, but none the better for all that. No matter how often the wires are pulled up around this corner they will get slack, for the stub will keep yielding to the strain, even though it is seven feet in the ground. The dotted lines show the original position of pole and stub. The guy is placed under the third arm, and the top of the pole itself will spring over several inches. The guy should have been placed just above or just below the top arm, or better still, two guys, one at the top and one below the lower arm. In putting guys on a pole, always place them so that the arm will be free for removal at any time. In Fig. 18 we have the most approved way of anchoring a stub

so that it will stay. The anchor is a heavy block at least 4 feet long, and buried from 4 to 6 feet deep (a railroad tie makes a good one), from which a heavy iron rod is brought to the top

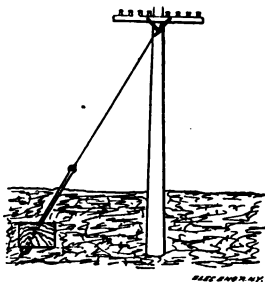

FIG. 19.

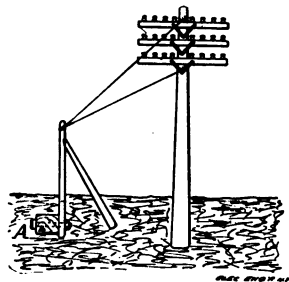

FIG. 20.

of the ground. If rocks are plenty, weight it down with them and tamp the dirt solidly.

In paved streets it might be well to fill in a foot or two with cement concrete.

In Fig. 19 is shown another method of guying, and the pole shown in Fig. 20 will hold, but in order that the back stub may not pull out, a cross piece about the weight of a railroad tie,

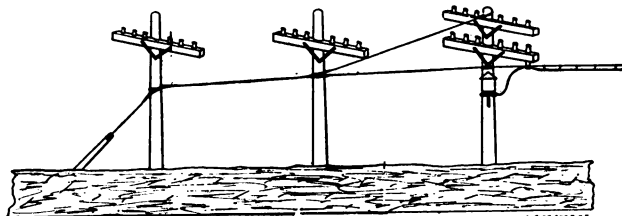

FIG 21.

and three feet long, should be buried about 3 or 4 feet in the ground and bolted to the stub at A.

In some places where the pull is heavier than usual, as at the terminals of cable spans, etc., the guy may be extended back over two, three, or even half a dozen poles, and finally

anchored, as in Fig. 21. If the pull on the guy is severe enough to mark the poles, a strip of galvanized sheet iron will prevent it, if placed underneath the wire.

These spans should be cut off and made up separately for each section, so that there will be no giving away at any part.

In going through the country, No. 6 wire or even No. 8 will be sufficient for all ordinary purposes, for if a heavier guy than a single strand is needed, two or more wires can be twisted together. Some companies use nothing but No. 9 wire for this

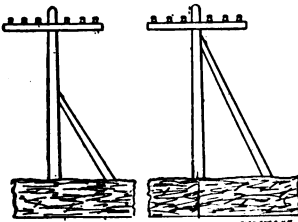

FIGS. 22 AND 23.

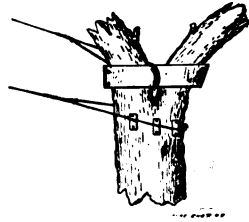

FIG. 24.

purpose. For anchors to stubs, 8 strands are twisted together while for heavy corners one or more of 4 strands each are used. Cables of this kind can also be bought from dealers. In Figs. 22 and 23 are shown bad and good methods of bracing. In some places the only available places to guy is to neighboring trees. If these trees are shade trees the chances are that their owners will make objections, but the guys can be placed in such a way that the tree will not be injured, if made as shown in Fig. 24.

Where a tree fork is to be had, the method shown in the upper guy is best, the wire being simply fastened to a block and placed in the crotch. If this cannot be done it is better to place it around the tree in a single loop and place blocks behind it. Never pass a wire around the tree so as to compress it since the growth of the tree will be stopped, or the tree will be injured in a year or two.

In "making up" a guy at the ends there are two or three things worth remembering. One is that a splice made two

feet from the point of support will be stronger than if made closer, and it also affords a chance to twist the wire and take up the slack between the blocks and point of support. Two inches can sometimes be taken up in this way.

In making up a cable, spread out the wires at the ends and twist them all in flat together. This will not only make a neat job but a much stronger splice than any other. The American Bell Company and some street railroad companies often use a clamp for this purpose, which is composed of two grooved pieces of iron drawn together by bolts which clasp the wire. Where guys are expected to stretch and give a little—as they

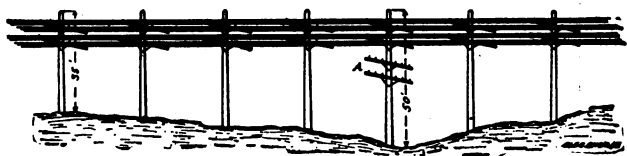

FIG. 25.

will in zero weather—a turn buckle will allow them to be taken up or let out as may be necessary.

As regards the height of poles there was formerly a notion among telephone men that poles should be as tall as possible in order to avoid the static induction and it is a fact that a wire 60 feet in the air does not possess half the static capacity of one 30 feet high; but the Long Distance Company after having several very important and costly lines prostrated by storms cut their country lines down to 30 and 40 feet.

As regards grading a pole line there are men who take pride in that sort of a thing, putting short poles on top of a hill and tall ones in the low places. One manager who likes this kind of work and having plenty of poles of all lengths, surveyed his line before building, and the result is a line like that shown in Fig. 25. In this sketch poles varying in length from 35 to 50 feet are graded to a level. The point, A, on the 50-foot pole shows how the line would look if the poles were all the same length.

CHAPTER VIII.

CORNER AND JUNCTION POLES, ETC.

IN turning corners, two poles should be used and placed close together, and in such a position as to break the angle as much as possible. Fig. 26 shows how this is commonly done. The use of double arms on the corners is to be commended, as it relieves the strain on the corner pins, and to a great extent on the pole itself, by distributing the pressure more equally.

In the illustration the arms are shown faced in line with the

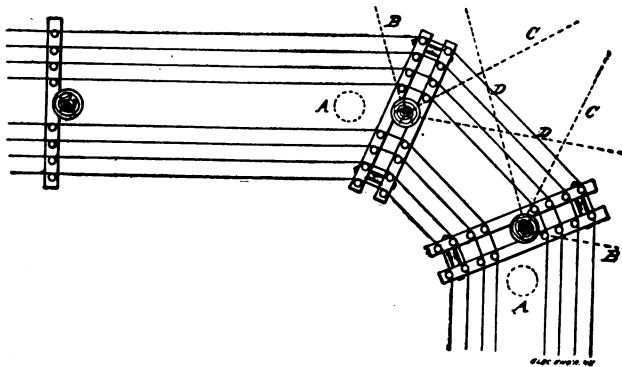

FIG. 26.

apex of the angle instead of at right angles to the street. This does not seem to be a matter of much importance, but a practical experience has shown that this is the best way, as the strain is against the arm in the line of greatest resistance, therefore relieving the tendency to warp. It also turns the corner on two pins instead of one, as would be the case if square with the street. It may be objected that the wires, as they approach the corner pole, are thrown closer together. Well, the difference

will not be much, but it can be avoided by the use of a longer arm. Suppose that the arm shown at the left in Fig. 26 is the ordinary 8-foot 6-inch short arm; by simply using 10-foot arms the lines will be kept at the same distance on the angle as on the straight line. It will not be a great deal of trouble to carry a few long arms in stock for this purpose.

CORNER AND JUNCTION POLES.

Fig. 27 shows the details of a double arm used at a cable or terminal pole. As wires from such a pole are liable to break off in at least two directions, double grooved glass, or better still, the heavy transposition glass should be used.

A, cross section of pole; B. B., arms; b, $\frac{5}{8}$ bolt of the required length; c, block to keep the arms at their proper place—gas pipe is sometimes used for this purpose, in which case use a large washer under its ends to keep from cutting into the arm. Again

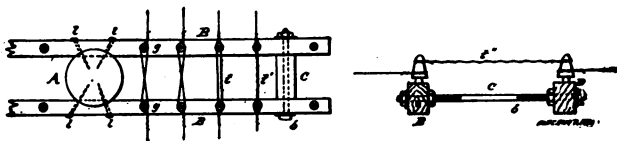

FIG. 27.

there are places where a single $\frac{5}{8}$ bolt will not hold the centre, but that can be varied to suit the circumstances.

Another device is that shown in the second figure, which sometimes takes the place of the block, c. It is simply a bolt with long threads at the ends. A large nut inside the arm allows of any desired adjustment, while the nuts on the outside clamp the arms firmly in place.

t' t'' (both figures) shows method of lashing pins together. Make a loop, t, with No. 12 wire, then twist together as in t' t''. This will hold the pins firmly in place against the pull of the wires.

Some men, however, prefer the figure 8 style, as shown in the first figure, g. g. The ends are passed around both insula-

tors in the form shown, but it does not make so neat a job as the other.

What is known to linemen as buck arms, at junction poles, are not desirable, but sometimes necessary.

The form shown in Fig. 28, however, should always be

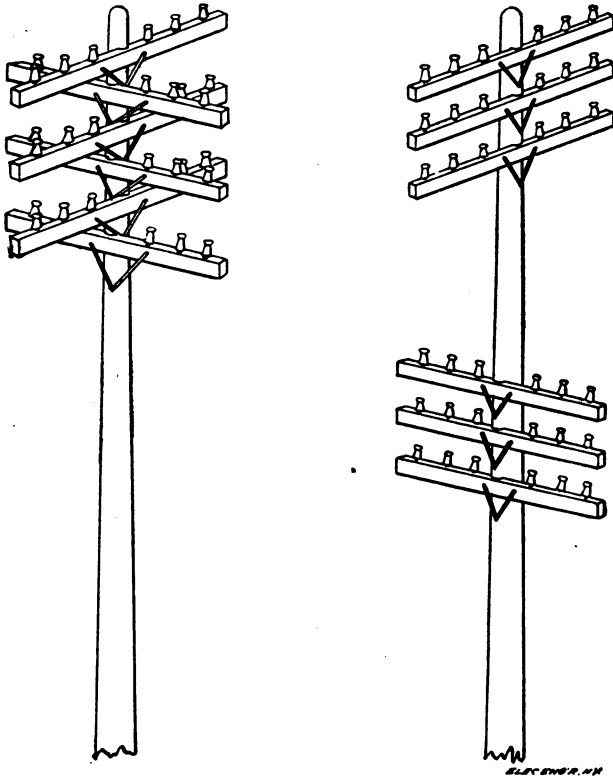

FIGS. 28 AND 29.

avoided, as the wires cross each other like sticks in a crow's nest, making it impossible for men to get through and do any

work, without making trouble. A much better plan is that of Fig. 29, provided room enough is left for more arms on the top section. This should be done even if it is thought that there will be no more arms up there, for this telephone business has a way of growing like Jack's beanstalk, and new companies should always expect about four times as many wires as they start in with, and it is always well to have room enough. Good work does not cost a great deal more than the other kind, and is much cheaper to maintain.

Still there are cases where it is necessary to have the buck

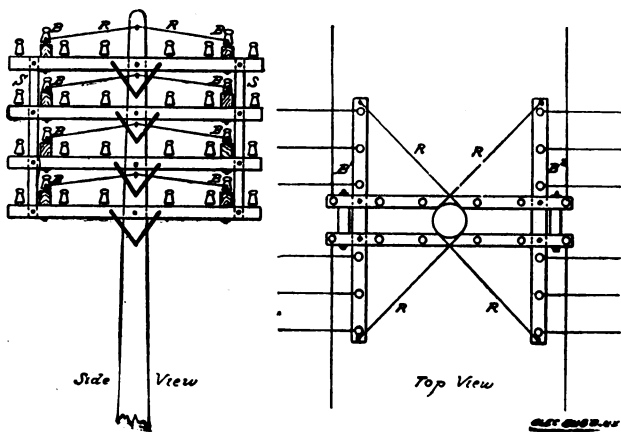

FIG. 30.

arms as high as the others. The use of a cable would avoid their use altogether, but this cannot always be done. In the side elevation as shown, Fig. 30, iron or steel strips, S S, are used to hold the arms rigidly in place and afford mutual support. These strips are $1\frac{1}{2}$ by $\frac{3}{8}$ inch, and long enough to reach all the arms. As these arms will be doubled, two strips on each end, or four in all, will be needed. They should all be bored exactly alike, and clamped together with bolts reaching through the arms and blocks. The buck arms, B B, are put out between

the third and fourth pins, and bolted down to the others. In order to afford them support, strips should be run from near the ends and bolted back to the pole with a short lag. These strips may be iron, 1 inch by 3-16 inch, or they may be rods, or even two No. 6 wires twisted together. Whether strips, rods, or wires are used, they should be raised high enough to clear the wires on the lower arm. It goes without saying that double groove glass should be used on the main arm, and the wires pull off from the lower groove, while the tops are lashed together. If necessary for wires to cross from one buck arm to another,

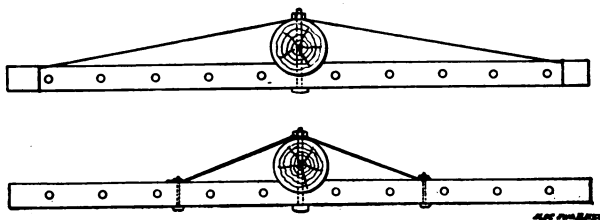

FIG. 31.

use insulated wire and pass through the double arms from one to the other. A junction pole rigged up in this manner will always leave room enough for the men to work around it and keep the wires clear much better.

In Fig. 31 are shown methods of bracing arms on curves when double arms are not used. The lower figure shows the use of ordinary braces bolted to the arm and united at the pole by a single lag screw or bolt, the same lag going through the large hole of both. That shown in the upper figure may be of strap iron or No. 8 wire passed around the end of the arm and neatly twisted together:

GUYS.

In Fig. 26 it will be noticed that there are several dotted lines running in different directions, to indicate the possible position of different guys. As the wire turns a corner the natural tendency of the pole is to slip back towards the centre of the

longest span, and if left free to move longitudinally, that is where it would go, but as it is fastened at the ground it cannot move back more than four or five feet, which would be about the spots marked, A A, provided that the only guys were the side guys indicated by the dotted lines, B B. Therefore, if the line must be side guyed in this direction, it will be necessary to put on other head guys, in the direction of D D. If, however, a stub can be so placed as to pull off in the direction C C, no other guys are needed, as this answers to both head and side guys. If the poles are close together, one stub will sometimes be sufficient for both. Remember that these stubs should be well anchored.

HOW TO CROSS-CONNECT ON TERMINAL POLES, ETC.

Some linemen, in running the cross-connecting wires on a pole—as from a cable box or changing the position of line wires—like to tie and lash them all together with twine or tape till they have a cable as smooth and stiff as a new rope. Now, this makes very neat looking work, but it is sometimes quite a bother in more ways than one. In the first place, suppose it becomes necessary to change a conductor, as is often the case. To do this the lashing must all be untied, or cut, leaving the whole mass in a disordered condition, and once in this condition it is apt to be left so.

Again, with the wires bound tightly together the insulation is lower, and sometimes breaks down altogether, to say nothing of its retaining moisture after a rainstorm, and glueing together in hot weather. When it is necessary for wires to be bunched, the more loosely they lie together and the more free air is surrounding them, the better the insulation will be.

The best way to do such work is to run the wires in such a way that each individual one can be traced out, pulled out, or inspected, and Fig. 32 shows such a method. First, on the pole and on the arm next to the pole drive gas-pipe staples, at distances of 12 inches apart, and pass the wires through them. One of these staples will hold 50 wires without crowding very

much, or if more than 50 wires are required, larger pipe straps wound with tape will answer; but two rows of staples, one for each side of the pole, will accommodate 100 wires easily, unless the insulation is very heavy. When the arm is reached, drive one staple on the side of the arm, under each pin; and for the three outside pins, galvanized fence wire inch-and-a-quarter staples will hold three or four wires, and are therefore large enough. Where double arms are used, keep the staples on the inside, where they will be out of the way.

Never run the wire across the top of the arm, except at the insulator pin, as otherwise it will be trampled on, and the insulation worn off and perhaps broken.

Most linemen like to take a turn or two of the wire around the insulator, as in that way they have some slack wire if they

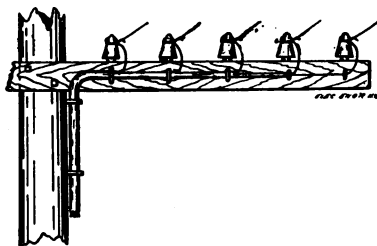

FIG. 32.

need it, or enough to make another connection if broken or changed. It is best not to make this connection directly on the line wire. Instead, when the line wire is fastened to the glass, leave an inch of the end stick out, and when the copper wire is brought up, fasten and solder to this end; and turn it down alongside of the insulator. By so doing the line will not be weakened by rust at this particular spot, as is often the case. Some construction men use a connector, like a battery connector, at this spot; don't do it, it will make trouble.

Wire for this kind of work should not be smaller than No. 19, and either triple braided weatherproof, or rubber covered

and braided. Never use office or annunciator wire for outside work.

TREE TRIMMING.

One of the greatest annoyances to the telephone man are trees, especially as permission to trim them cannot always be obtained. The use of insulated wire does very little good, as the insulation is soon worn off. Where there are 20 or more wires it is generally cheaper to run a cable low enough to pass under the heavy limbs, with junction boxes at 500-foot intervals, for local distribution. In this way, more than one arm will not be necessary.

When trees have to be trimmed, do not be satisfied with lopping off the twigs and ends of the branches, for next year the tree will be as bad as ever, and besides, its appearance is anything but artistic. Send a man up and cut the branch off close to the trunk and cover the end with paint, and it will make no further trouble. Many a time the tree can be trimmed so as to not only clear the lines, but look as well as before.

CHAPTER IX.

CABLES.

WHILE it is taken for granted that cables will be used from the office to the different leads, they are also, many times, a necessary part of pole line construction. While not affording as good insulation as aerial lines they are more sightly and convenient than an equal number of bare wires could possibly be, and they also reduce the trouble account very materially; are not influenced by wind nor often by sleet storms and once properly put up and tested out make no further trouble till they wear out, which generally takes a long time.

On streets where trees are numerous and troublesome the only satisfactory service for a large number of wires is cable service, with distribution boxes at places most convenient, and with only one or two arms on the poles, for local distribution. One case we can recall especially where 14 or 15 arms were replaced by a cable of 204 wires is worth mentioning:

The cable was run out nearly half a mile from the office, till the distributing centre was reached and a great many wires were taken off, when it changed to a cable of 102 wires, and about a mile from the office was replaced by one of 52 wires when the suburbs were reached and the rest strung out with wires in the usual way. At every second corner the cable was looped into a terminal and both conductor ends brought to, and united at the terminal posts, as shown in Fig. 33. Thus every conductor could be found and if need be tested and used at each box. (In some cases of this kind a certain number of pairs only are taken into the terminal posts, say, from 1 to 20 at the first box, 21 to 40 at the next, and so on; but the best plan is to bring them all in, where they can be used for party lines if necessary, or tested

back, in case of an "open," or even cut out in case of a "ground" beyond the box.)

Previous to this the service on this particular lead had been anything but an ideal one, but with the cable it seemed to leave nothing to be desired. We have seen cables run through residence streets suspended to trees with a short pole used occasionally to help out the distribution, thus carrying from 30 to 50

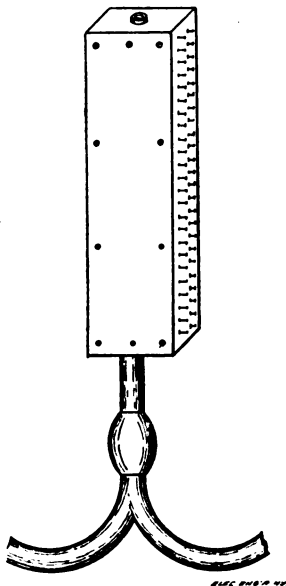

FIG. 33.

wires in places where pole line work would have been impossible. Here is a hint for our electric lighting friends. In many places such as this, a duplex lead covered cable would give better service than the flimsy insulation that is much used on overhead line wires at present. Trees and light limbs then need not be feared, and much tree trimming and other troubles be

avoided. While there are many different makes of cables, there are only three kinds in general use.

In some, and the earliest forms, the conductors are covered with rubber or gutta-percha compounds, such as Okonite or Kerite.

These furnish good insulation and are much preferred in telegraph, or electric light work, but they are not the best for telephone work generally, because their electrostatic and inductive capacities throw in retardation and cross talk. They should therefore be used only in short lengths though the objection to them is sometimes partially met by wrapping each separate pair (nearly all cable conductors are twisted in pairs) with tin or lead foil which is grounded in the office or to the common return.

Lightness, flexibility, and ease of handling are the desirable features of this class of cables.

Another of the older methods of insulation consists of cotton or jute thread soaked in either asphaltum, Ozite, paraffine or creosote, protected by lead armor which shields the conductors against outside induction. This lead armor is also grounded in the office or sometimes takes the place of the common return, its bulk making its resistance negligible. Last, but not least, we have paper either dry or paraffined and lead covered. The best insulation for electrical conductors is dry air, and a special kiln dried fibrous paper furnishes the nearest approach to air at anything like reasonable cost.

But while dry paper is the best, it is also a source of weakness, for it will absorb dampness very rapidly if exposed. To prevent this, the ends for a few feet back are generally filled with pitch or paraffine, sometimes hardened with rosin, or beeswax, to prevent absorption of moisture when the cable is opened.

In some cases, however, where there is a great deal of underground work, and the work of handling cables is well understood, these compounds are left out even at the ends, the joints or terminals being quickly put on and paraffine poured over the joints only, to drive out the trifling amount of moisture that

may have accumulated. But the body of the cable being simply kiln dried paper, it is easily seen that a very slight puncture in the lead covering means dampness and low insulation. And let us say right here that when a cable has been left open an hour or so, and boiling hot paraffine poured into it, the bubbles arising in the liquid will show that some moisture has been absorbed, even on a very dry day.

Persons not familiar with cable work, had best not undertake to put up a very large amount of it, and it would probably be cheaper in the long run to arrange with the manufacturers to send some one to supervise the work, unless certain that the force on hand can manage it. In New York City it is usual to let the contract to the cable company direct and require a thirty days' test, the tests being carefully made and severe.

Still a few hints on the subject may not be amiss.

Aerial cables cannot be handled too carefully. Don't forget this, or let the men forget it. Do not pull a lead cable over the arms and leave it hanging there, as certain farmers have been known to do; perhaps under the impression that they could treat it the same as if it were a trolley feeder.

As it does not improve a cable to have men tramping over it, try and keep it out of their way by putting it in places where they won't have to step on it in getting up and down the pole; put it far enough out to allow them to get by it, say, outside the nearest pin.

Keep a sharp lookout for punctures and instruct all hands to do the same. See that all nails, and cleats or anything liable to injure the cable are removed from the inside edge of the reel. Do not let the men open a cable out of doors or indoors for that matter—after one o'clock, unless sure they can finish it that day, for a cable once unsealed should be finished and sealed again as quickly as possible. Once upon a time some men opened a cable to put on a terminal head at 4 o'clock p. m. At 6 o'clock it was not half finished, but they went home for the night, leaving the terminal uncovered, and slept the sleep of the

just. Mist in the early part of the night; and a northeast rain and snow in the latter part, and a well soaked head. (A cable head is not benefited by a soaking even in ice water.) Several bad conductors, cross talk between every one of them, and more from the subscribers. And the man responsible for all this, with the nerve of a train robber, tried to get an extra discount from the company that furnished the cable on the ground that the cable was no good in the first place.

The first thing to be done before putting up a cable, is to hang the suspension wire. This may be as small as No. 6 for short spans or No. 4 for spans not exceeding 100 feet—that is, for a 100 wire lead covered cable—but the best span wire is a manufactured cable composed of seven strands. These strands should not be smaller than No. 12, and for spans of 150 feet, seven strands of No. 10 is about right. Of course the terminal poles at each end of the cable must be guyed beyond the possibility of their giving way, for if not drawn tight the span wire will soon begin to sag under the weight of the cable, and while a sagging cable will probably give as good service as any, yet it has a disreputable look and work of this kind leads to a demand for underground construction. If the overhead work is all it should be, there will be no demand for underground work, except in the largest cities.

Do not try to pull out a 2,000 foot length of cable from one end and expect to have it free from trouble, as the strain on the cable will require a team of horses to draw it before it gets through. If thought desirable to draw out 2,000 feet in one piece, which is not advisable except by the most experienced men, place the reel at a point one-third the distance to the terminal pole, and when that is drawn out and suspended draw the rest off the reel, coiling it on the ground in the form of a figure 8 twenty or more feet across, this being done to prevent kinks. Then start the inside end back the other way. In some places the cable may be all laid out on the ground and the hangers put on the end. Then raise the end to its position on the

pole and a man in a boatswain's chair can follow the span wire and hook it on.

The chair may be suspended from a snatch block which travels over the span wire, the block being one that can be opened at the side and changed as the poles are reached. If the hangers are of a kind that can be readily put on by hand—as clip hangers—another snatch block carried on the span wire by its hook with the cable passing over the pulley and pulled ahead from the next pole will lift it up so the man in the chair can handle it, the chair being also pulled along. But the most common method is to have men enough to man each pole, put on the clips as they leave the reel, and as fast as they come up the man on the first pole hooks about every fourth or fifth one on the span wire and when the next pole is reached a man there unhooks them, passes them around the span wire support and hooks them on again, the same operation being repeated at every pole—note if malleable iron hooks or clips are used; they should be placed about 18 or 24 inches apart. As the last section is being pulled in, every hook is then placed on the wire so that when pulled through that part of the work is done.

Another method much in favor with some companies is to pull the cable through in snatch blocks placed every 50 feet apart and hung from the span wire afterwards, suspending it with marlin yarn or wire. In New York City marlin is used, in Brooklyn No. 14 steel wire. This is wound on with what is commonly called a spinning jenny; it consists of a hollow wooden cylinder split in two parts and large enough to cover the cable and span wire. It is brought together over both the cable and span wire and wound on the outside, with marlin enough to reach the next pole. The marlin end is then securely tied around the cable and span wire and the jenny rapidly pulled through to the next pole with a rope, the yarn slipping off as it is pulled along. At the next pole what remains of the yarn, or wire, is taken off and the operation repeated till all the cable is in place. It is claimed for this method that the cable lasts longer than when hangers are used.

In estimating the amount of cable required, always allow for a few feet extra at each end in order that it may be bent down the pole and brought up into the terminal box. It is also best to cut off two or three feet from each end, as that part of the cable is apt to be bad.

The cable should be brought into the box from the bottom, as also the connecting wires, in order to keep the inside of the box as dry as possible. The inside of the box should also be painted with either shellac, or asphaltum—P & B is one of the best asphaltum compounds for this purpose—for the same reason.

If the cable is a long one, ground strips and lightning arresters will be necessary, so that the box should be made large enough to include these.

The cable companies nearly always furnish compounds for filling the terminal head, but if this is not at hand a mixture of paraffine and beeswax will answer very well. Pour in boiling hot.

Wires with connections inside the head should be soldered, as a general rule. There is a solder that is made up in thin hollow strips, with acid salts in the centre, that is best adapted for this work. As the wires will nearly always be found in twisted pairs, arrange to keep them together in regular order, so that the mate to any conductors can be found, when it becomes necessary to run metallic circuits.

CHAPTER X.

UNDERGROUND CONDUITS.¹

IT sometimes happens, even in small towns of 1,000 subscribers or less, that a new company will find in certain districts, so many poles and wires belonging to railroad, power, electric light, telegraph and other companies, that the least troublesome method is to put the cables underground. In some places, digging in unpaved back alleys is easy, and the work may be even as cheap as a heavy pole line, with the necessary span wires, slugging and guying.

Of course if the digging is hard, and pavements have to be torn up, that is another matter.

The cheapest duct, and about as good as any, is a creosoted wooden pipe. It needs no cement to hold it in place, for the dirt can be simply thrown back and tamped down on top of it. It will last a great many years, or at least, will not wear out in an ordinary lifetime. The joints should be sealed up with tar, or wrapped with burlap, to keep out dirt and water. In sections where lumber is cheap, a number of ducts can be "built up" in sections three inches square of plain rough inch or inch-and-a-half lumber, which may be tarred or painted. Do not fasten the cable in with pitch if you ever expect to draw it out again. If this kind of conduit is used, however, iron pipe should not be used in connection with it, unless sure that it will be perfectly free from illuminating or sewer gas as well as electrolysis. Many manhole explosions in cities can be traced to this cause. This is not to be taken as condemning iron pipe, but means that ducts exposed to gases should be either all of non-conducting, or all of good conducting material, to prevent a difference of potential and sparking between the cable and the duct tubes.

¹The writer wishes to acknowledge indebtedness to the Standard Underground Cable Co., of Pittsburg, Pa., and to John A. Roebling's Sons Co. for some of the suggestions contained in this chapter.

Suppose for example, we have several thousand feet of cable in wooden or tile ducts. Now, this duct being in the ground and more or less damp, would allow a certain amount of leakage to take place, so that if all the cables are connected together, a generator tried on the lead covering would show a very good ground, but this ground extends pretty equally over the entire system—for if a single cable were tried it would test “open”—and distributed in this way it is a very good thing as it clears out the static charge. It also prevents sneak currents from getting in, by interposing such a high resistance that they cannot get there in quantities in any one spot to do any harm.

Now, it often happens that at a manhole a cable is taken up a pole, or side of a building, and on account of its convenience in bending, an iron pipe is used. Suppose, now, as often happens, that the manhole gets just enough gas in it to become as explosive as gunpowder, and only requires a spark to set it off. Suppose again, that the lead covering of the cable receives a static charge from the overhead lines, or a back current from a street railroad track, or a cross with an electric light wire outside. With wooden or tile ducts it would distribute itself equally and harmlessly over the entire system, but with an iron pipe affording a fairly good ground, the visiting current goes that way with a rush, and as the inside of the pipe is apt to be more or less dirty and rusty, there will be just resistance enough to make a spark, and then—explode! If any of my readers have ever seen a manhole cover weighing 500 pounds and fastened down with heavy iron bolts, rise up in the air and land on the roof of a four-story building, I am sure they would consider this kind of thing worth guarding against.

If all the ducts were of iron, it would also distribute itself probably without sparking, for the resistance of the lead cover to any but the heaviest currents is practically negligible, so that if the cables are all connected together, as they should be, the potential of the whole system is practically equal. But iron pipe exposes cables to stray currents and electrolysis from the trolley roads, and while there is a great deal of iron pipe used,

I do not think its use is to be commended. There are iron pipes made with a glaze on the inside, and others lined with cement, but I cannot be convinced that they are as good as wood or tile.

The best but most expensive conduit now being laid is of tile or terra-cotta, with a smooth glaze on the inside.

It is never troubled by electrolysis, is a fairly good insulator, and never decays—though in cities where streets and alleys are continually torn up this is a doubtful quantity.

In order to make good work it needs to be laid in cement; though this depends somewhat on the nature of the soil. Conduits are also sometimes formed entirely of cement, the ducts being formed of paper or sheet iron tubes, and as its only use is to hold the form till the cement can set, it does not matter how long these frail tubes last. The size of the duct should not be smaller than $2\frac{1}{2}$ inches, and 3 inches is better still. A tube that fits the cable too closely will be troublesome when drawing in, and a very little dirt may cause it to stick altogether. The duct might be made larger than this with the idea of carrying two or three cables, but this is not a very good plan, as all the cables would have to be pulled through at the same time; for another cable cannot be pulled into a duct after one has already been inserted. But there is no necessity for pulling two telephone cables into one duct if ducts enough are put down in the first place.

Always make allowance for four times as many ducts as you think can ever be used, for it costs no more to dig a trench for ten ducts than for three, and the only extra expense is for the tube itself. Besides, it may become necessary to change the cables some time, and in such a case an extra duct is very convenient.

It will not do to forget that with cheaper service the time will come when a telephone will be placed in every house, and while planning underground work, make the conduit capacity equal to the number of householders in that vicinity. Even with the high rentals prevailing in New York City, the conduit capacity in

some districts has fallen far below the requirements, although at the time they were laid it was supposed there would always be some of them vacant.

In the early days of electric lighting in New York, Mr. Edison planned his system with the idea of supplying every house with light. This at the time seemed like planning a long way ahead, but in less than ten years even his far-sighted engineering proved inadequate, and his feeders had to be reinforced.

Why, in some Western towns where competition has cut the price of party lines down to \$1 per month, half the houses in town already have telephones, and even farmers are waking up to the great convenience of this instrument, and some of my acquaintances are beginning to cater to this class of business.

All underground cables should have an alloy of tin in the lead covering, the amount being about three or four per cent. This applies to aerial cables as well, as pure lead, which is sometimes used, is too soft, and inclined to "creep;" but the real object of the alloy is to prevent corrosion. Sometimes the tin is put on the outside as a coating instead of being used to form the alloy. Customers can take their choice.

CHAPTER XL

MANHOLES.

MANHOLES are also a necessary part of conduit work. They should be large enough to allow a man to get into and do the necessary work of splicing, etc. They should also be lined with brick set in cement; and the floor may be cement, with a drain in the bottom, or if the soil is porous enough, have no floor at all, except some coarse sand thrown in the bottom to keep it clean (Fig. 34).

They should not, as a rule, be more than 500 feet apart, though 1,000 feet of cable can be put through in one length, but where this is done it is better to select the middle manhole and pull both ways from there, as described in a previous chapter on aerial cables. The ends of the ducts in the manholes should

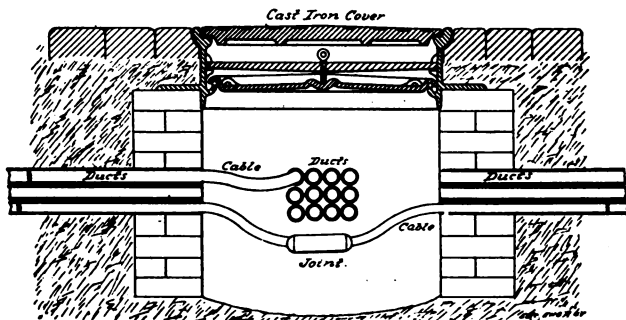

FIG. 34.

also be reamed out, so that no sharp corners, or projections, can possibly mar the cable. They should also have cleats or hangers around the sides so that the cable can be kept out of the way.

There is a diversity of practice in regard to keeping water out of ducts and manholes. Some will use their utmost endeavors to seal up both ducts and manholes, so that no water can possibly get in—but it does just the same—while others make no effort to keep the water out, but put a drain connection at the bottom of each manhole. Others still make no effort either to keep water out or drain it off. If they should open a manhole and find it full of water, they simply pump it out till their work there is finished, and let it go at that. If the soil is sandy or porous, it will absorb all the water liable to accumulate in any conduit system. The manhole covers should, however, be as nearly watertight as possible. Water does not hurt a lead covered cable, and there is no particular use in trying to keep it dry underground.

In London it was the practice to even fill the conduits with water, presumably to keep the cable as cool as possible, and counteract the effect of steam heating pipes. In some downtown districts in New York City, the temperature of the ducts, in places, is almost that of boiling water.

In getting a cable into a duct the first thing is to get an inch rope pulled in. There are various ways of doing this; the simplest way is to pull in a No. 14 steel wire as the duct is laid, and when needed hitch a rope to it and pull it through. Another method much used, is to have several hundred sticks about four feet long, with brass screw joints on each end, one being a male and the other a female thread. As fast as one stick is pushed into the duct another is screwed into it, and so on, till the next manhole is reached, when the rope is hitched in to a swivel, made to screw into the end of the stick, and the man at the next place pulls it through, unjointing the sticks as fast as they arrive.

T. J. Cope, of 3244 North 15th street, Philadelphia, advertises a machine that works its own way through the ducts, cleaning out dirt and other rubbish as it goes along. According to his advertisement he has cleaned and threaded about 9,000,000 feet of duct with it. From illustrations it appears to be

made on the same principle as certain types of boiler tube cleaners.

To fasten the rope to the cable, spread out the end and pass down over the end of the cable for about two feet, then lash it tightly, with marlin twine, or wire. Some contractors use an iron clamp that passes down over the end of the cable, similar to that on a wagon tongue, when a couple of holes are punched through the cable, and rivetted or screwed down, the rivets pass-

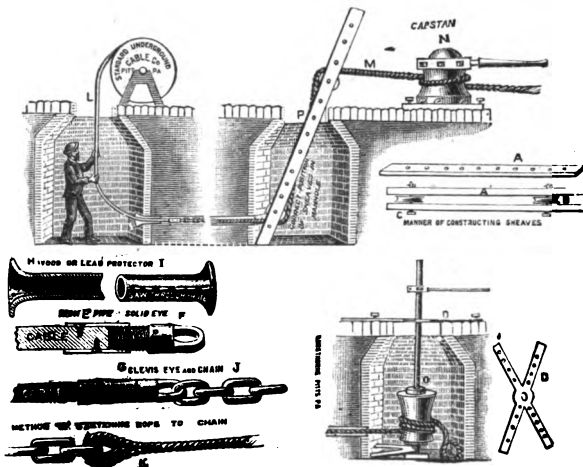

FIG. 35.

ing through holes in the clamp for that purpose. A loop in the end of the clamp permits of fastening the rope.

To pull through a length of 500 or 1,000 feet will require considerable power; cable contractors use a winch and capstan for this purpose, so constructed that it (the winch) can be placed in the manhole, while the men can work the capstan bars above ground. But where there is not cable enough to justify this expense, double pulley blocks will do almost as well. The method of using capstans in different positions is illustrated in

Fig. 35, which shows the apparatus employed by the Standard Underground Cable Co., Pittsburg, Pa.¹

In districts where few wires are taken off, a heavy pole probably furnishes the simplest method of distribution, using either double arms faced at right angles to each other, or a circular iron ring about 6 feet across, and held in place by braces made to fit ring and pole. The ring is of angle iron with the lip of the upper angle turned outward. Angle braces are made to fit this ring and pole, both above and below. Around the outer projecting lip of the rim are drilled $\frac{1}{4}$ -inch holes about 4 inches apart, and through these is passed a bolt to connect two porcelain knobs—one above and one below the lip—thus making place for two wires at each drilled hole. Where a large number of telephones are to be served to one building, as a large office building, the best way is either to come up the side of the building to the roof, or else to take the cellar, and distribute from there.

It is sometimes very convenient to divide a cable into several parts, as described before, but with a difference. Suppose we have a 200-wire cable, which we wish to distribute at four points, A, B, C and D. At A, we will need, say, 50 wires. We take the first 50—for by this time the cable should be numbered at the office end. Now, as we may want some of these wires again, we will not cut them here, but merely “tap in” (multiple) and continue to the next terminals.

From this “split” we run a short 50-wire cable to its terminal outside. At the next station, B, the next 50 wires are tapped; and it might be well to also tap it on the first 50 at this point, as they may be needed to help out the distribution; for one terminal might have more subscribers than it has conductors, while another will have plenty of conductors to spare, and it may be found very convenient to tap some of them. Then the cable may be changed to one of 100 conductors, and connected to C and D, the same as at A and B. Some companies, how-

¹Fig. 35 is reproduced by permission from a handbook by the Standard Underground Cable Co., Pittsburg, Pa.

ever, would bring the whole 200 conductors into each terminal. We suppose here we ought to stop and give some directions for making a cable splice.

Bring the two ends together and past each other about a foot or more, according to the amount of end to be wasted. Then strip the lead back till there is about a foot between the two lead sections. Then take a piece of lead pipe a little larger than the cable, and a little longer than the space that separates them, and slip it back over one of the ends. In making joints twist the two ends of the wire together, but before doing so slip a sleeve either of paper or cotton over one of the wires so that when twisted it can be slid over the joint. These wire splices are not generally soldered. In making joints distribute them as nearly equally as possible, over the space between the two ends to prevent bunching, and keep the pairs together.

When the joints are all made and the short lengths of tube slipped in place, pour over them a mixture of paraffine and beeswax, or whatever is being used; then slide the lead sleeve so as to cover the two ends, and make a "wiped" joint. If the men handling this work don't know how to wipe a joint, hire a first-class plumber to do it, and be sure that the joint can be depended on not to leak, though the plumber should understand this.

In making a tap (split) joint, three ends are brought together instead of two. (See Fig. 36.)

Some men like to leave a hole in a joint sleeve, and fill it full of insulating compound, soldering up the hole again afterward.

REMARKS ON ELECTROLYSIS.

With wood or tile ducts, the "ground" on the cables should be so evenly distributed over the entire system that there should be no trouble with electrolysis. As said before, the same class of duct should be used even to the foot of the pole, or, if it is necessary to use iron pipe, do not extend it into the earth more than two or three feet from the top of the ground, and

wrap that part of it in burlap, thoroughly soaked in tar, to prevent direct contact. Of course a cable up the side of a pole, or house, needs some protection, but tile can be found to make the bend at the foot of the pole, and galvanized sheet iron bent over the cable and nailed down, is almost as efficient.

Now, the only trouble from electrolysis comes from street railways, or power circuits, with a ground return, and is caused by an escape of current from the ground wire. Suppose there is a loss in the trolley wires, from the power house to the end of the line, of 250 volts, as frequently happens. Some of this is used in overcoming the resistance of the conductors, but a

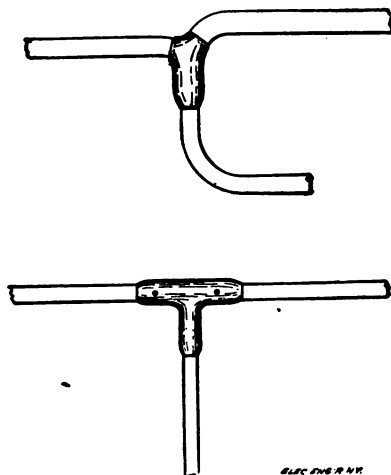

FIG. 36.

large part of it is lost in the ground return, and a great deal of it strays away to water, gas, or cable pipes in the vicinity. Now, where the current enters these pipes there is no harm done, but when it leaves them again like a freebooter that it is, it takes part of the pipe along with it. (The text-books say that it sets free oxygen, which enters into active combination with the metals, but the effect is just the same.)

Its presence is indicated by decay and pitting of the pipes affected, and a visit to the power house should be made forthwith. If it is found that the negative bus-bar is the one connected to ground, there is nothing more to be done there, unless it may be that the ground return is not heavy enough, in which case you may be able to make some arrangement in regard to it. (If a bonded track return only is used, it is a very uncertain factor.) If the positive bus-bar is connected to the ground, it should be changed.

But if everything is all right in the power house, there is only one thing to do: to go back to where the damage is being done and connect the cables or pipes to the track return with a heavy copper wire; and if any more signs of decay are found to continue to connect it at intervals of every half mile or so, that is, provided it parallels the track that far.

All this will have a tendency to make a noisy cable, but it cannot be helped.

Electrolysis of course does not bother aerial cables to any extent.

As the static capacity, inductive and electrolytic effects are largely increased by the proximity of the earth, underground are therefore not as desirable as aerial cables, for with an extensive underground system metallic circuits become almost a positive necessity and the only thing to be said in favor of an underground system is that it is not affected by storms and, therefore, gives continuous service. It does not obstruct the streets with hundreds of wires, some of which are liable to break and cross electric light and trolley wires.

The city of Pittsburg has had a lively experience of that kind in one or two blizzards last winter, 1898, when men were shocked, horses killed and the rest of the citizens terrified into nervous prostration—at least the newspapers said so.

The static capacity of bare wires overhead varies from .0144 to .0160 microfarads per mile, while underground paper cables vary from '06 to .10 microfarad or from five to seven times more and induction effects in about the same proportion.

The nearer we get to the earth, the greater the wave distortion and success in telephony depends very largely upon our ability to preserve these waves in their original form.

The following specifications follow closely those laid down by the different Bell companies:

1. Each conductor shall have a diameter of 40 cir. mils (No. 19 B & S, though they are sometimes larger than this and may be even as small as No. 22), with a copper conductivity of 98 per cent.

2. The conductor shall be insulated, with two paper tapes, twisted in pairs, the length of the twist not to exceed three inches, and formed into a core arranged in reverse layers.

3. The core shall be inclosed in a pipe composed of lead and tin, and the amount of tin shall not be less than 2.9 per cent. The pipe shall be formed around the core and shall be free from holes or other defects and of uniform thickness and composition.

4. The average electrostatic capacity shall not exceed .080 of a microfarad per mile, each wire being measured against all the rest and the sheath grounded; the electrostatic capacity of any wire so measured shall not exceed .085 microfarad per mile.

5. Insulation from 100 to 500 megohms (100,000,000 to 500,000,000 ohms) per mile at 60° F. and a conductor resistance of not more than 47 ohms per mile connected to terminals.

CHAPTER XII.

CABLE TERMINALS.

OF course all cables must have means for connecting the cable conductors to the lines outside or in some cases changing conductors from one cable to another.

There are only about two or three forms of cable terminals in common use, and one of the oldest of these is shown in Fig. 37.¹

In this terminal the top, front and back are made of hardwood, the two sides, D, being usually constructed of hard rubber,

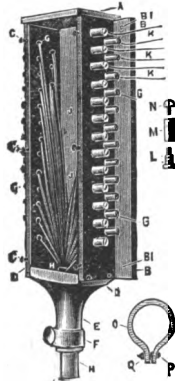
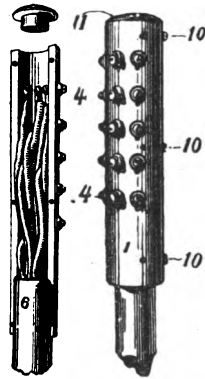

FIG. 37.



FIGS. 38 AND 38a.

in which are mounted the binding posts, c, by means of which a moisture-proof connection is established. The terminal is fastened against the back of the cable box, the end of the cable is passed through the grip, E, and held there by the band, F (this can be soldered by a wiped joint if preferred). The cable con-

¹Figs. 37 and 38 are reproduced by permission from the handbook of the Standard Underground Cable Co., Pittsburg, Pa.

ductors are then spread out, the necessary amount of insulation stripped off, and the wire passed through the back of the binding post, which is shown in detail at L, M, N, and thus connection made to the wires outside.

Another form of this cable is simply a cast-iron box, with the back, sides, top and bottom in one piece, and the front in another, with a thin soft rubber strip underneath to make the joint airtight, the binding posts being bushed with hard rubber. This is a very strong and substantial head. In both these forms it is common to fill part or all of the head with insulating compound poured in hot. The wires are frequently soldered to the binding posts on the inside.

The tubular terminal (Figs. 38 and 38a) is considerably cheaper than the above mentioned, and its simplicity, lightness and the small space it occupies, makes it very popular in many places.

It is composed of three parts; a split tube and a cap. One of these parts contains the binding posts, which after the end of the cable is stripped back is fitted down over it up nearly to the bottom posts. Alongside of each binding screw is a small hole in the rubber tube, through which the wire is pushed and connected to the lower part of the post outside, instead of inside the terminal, the line wire being fastened to the upper part.

After all these connections are made, the other half of the tube is fitted on and held in place by screws, and an insulating compound such as ozite or a mixture of rosin and beeswax is poured in until full, and the cap fitted on while it is still warm, thus sealing it up tight. Note—In pouring these compounds into the cable keep them hot till all air bubbles cease to rise, for then only is all dampness removed.

Fig. 39 shows a design frequently used by the writer, which, however, is not new. The cable is stripped back from the end as in making a cable joint; rubber insulated wire is then connected and soldered to the paper-covered conductors, the wires being long enough to reach the binding posts. A lead sleeve is then slipped on long enough to cover all the joints, with room to spare, after which the sleeve is soldered on with a wiped joint

and filled full and running over with hot insulating compound, which must be of a nature that will harden when cool.

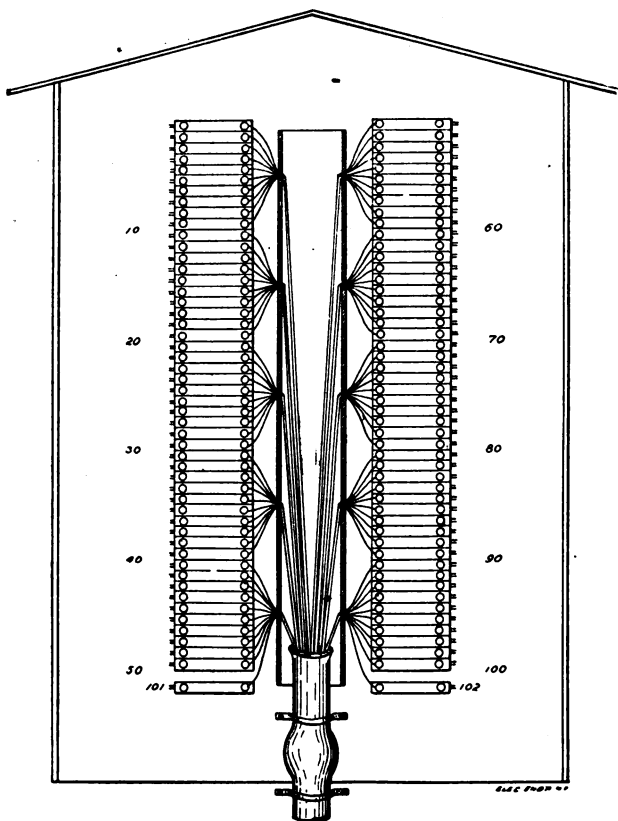

FIG. 30.

The wires are distributed by means of two parallel wooden strips set up on edge and fastened to the back of the box, the wires being distributed directly to the line terminals without the intervention of binding posts.

These wooden strips, after all holes are bored, should be plunged into boiling paraffine, or thoroughly coated with P. & B. paint, though ordinary asphaltum or shellac will answer.

For convenience in counting, the wires in the illustration are divided into groups of 10 each. A $\frac{3}{8}$ -inch hole will generally be big enough for 10 wires. The advantage of this terminal is cheapness and simplicity, and it is becoming very popular with construction men.

COUNTING TERMINALS, ETC.

The system of connecting and numbering the posts on cable terminals should be uniform throughout the plant, the following being the usual way. For terminal posts on the side, Fig. 37:

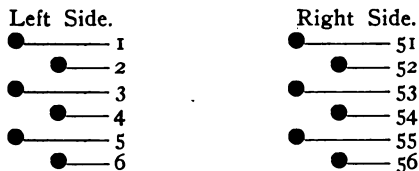

It will be observed that most of these terminals are fitted up with 102 or 104 posts, in which case it is better to have the 26th post on each row regarded as an extra and called 101 and 102 respectively; this keeps the rows in multiples of 25 and facilitates counting, the same idea being shown in Fig. 39.

With tubular and some cast-iron terminals with four rows of posts down the front, the counting begins at the left hand row, and counts straight downward, except as to the 26th and 101st posts, which are left for 101 and 102, thus keeping each row ending on some multiple of 25. Follow a systematic method in keeping the pairs together, as 1—2, 3—4, 5—6, or 1 to 51, 2—52, 3—53, etc.; then if necessary to use metallic circuits, the pairs can be easily found and kept together.

In some cases where a metallic switchboard is used it is customary to number the cable conductors in pairs. Thus, in Fig. 39, 1 and 2 would be numbered as No. 1 pair; 3 and 4 as No. 2 pair; 5 and 6 as No. 3 pair; or, 1 and 51, 2 and 52, 3 and 53, etc.

This latter plan is convenient where half the conductors are brought to a bus-bar as all of them on the right-hand side can be connected together, and if any of the lines are made into metallic circuits they can be simply disconnected from the bar and connected to the line outside.

In many places where cables are comparatively short, as at office poles, one side of each pair is connected to a bus-bar in the box, which is connected to the common return wire, thus keeping each circuit separate and full metallic out to the box, then, if a metallic circuit is needed, the conductor is simply disconnected from the bus-bar and connected directly through. This method is very much used in the latest work now being done. It has the merit of preventing a great deal of cross talk in the office end of the lines. With a paired cable there will be a tendency towards cross talk if the pair is run as two single lines, although it should be confined to those two only, if the cable is all right otherwise.

Speaking of those mixtures of rosin, beeswax and paraffine, I have not given the proportions of each because they have to be changed to suit the different conditions. In cable heads, for instance, harden by putting in more rosin, while on cable joints they should be soft. A few minutes experimenting will give the right proportion.

FUSES AND LIGHTNING ARRESTERS.

Fuses are used to open the circuit in case there is an excess of current on the line which might destroy the instruments. The best and most convenient types of fuses I know of are those shown in Figs. 40 and 41. In Fig. 40 it is merely a mica strip, with thin sheet copper bent around the ends to which the fuse is soldered. There are two holes in the mica, h , h' , which are designed to let two or three turns be taken back and forth, the fuse, of course, being insulated with a cotton or silk covering, and provides a greater safety factor by having about six or eight inches of length instead of three. Or, if lead fuse wire is used, it may be wound around the outside of the mica two or three times to obtain the same result.

Fig. 41 has insulated fuse wire done up in a coil to increase the length and also to furnish a spot not surrounded by free air so that the fuse will go quicker.

Both the above forms are very convenient in testing, as the clip has only to be pulled out to open the line. Another form which has found favor in many places, especially with the underwriters, consists of a spring strip held down by the fuse wire. As long as the fuse is in good condition the strip will stay down, but should it become opened the spring flies up, throwing the two ends far apart, thus preventing the arc which often follows the destruction of a fuse. Even if highly heated, the tension on the spring will break the fuse and cut it out anyhow.

Both forms, Figs. 40 and 41, are almost as free from arcing and just as reliable on account of their greater length of fuse wire, and when mounted on porcelain blocks an arc, on a half ampere fuse, cannot be very dangerous.

In order to protect the switchboard, the fuses should melt

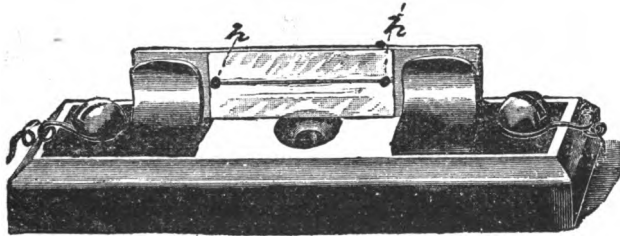

FIG. 40.

with any current above half an ampere within a reasonable length of time, say, five or six seconds. The easiest way to test this if an ammeter is not handy, is to take a 110 volt lamp, an old one that has burned 600 hours or more, which will use from .60 to .75 of an ampere; connect the fuse in circuit, and if it doesn't go in five seconds don't use it. If a 110 volt current cannot be had, use one of 50 volts, but with a new lamp, and, as a 50 to 55 volt lamp takes about one ampere of current, the fuse should melt right away in not more than one or two seconds.

In writing to manufacturers of fuse wire, be sure to state the highest limit of the current which it is desired the fuse shall carry, and also the length of fuse used, for a fuse two inches long will carry at least twice as much current as one six inches in length.

Fuses made of lead wire are apt to increase in their heat carrying capacity, and a fuse wire which when new, will blow at half an ampere, may stand one ampere after being in place a few months; on this account some managers insist upon having

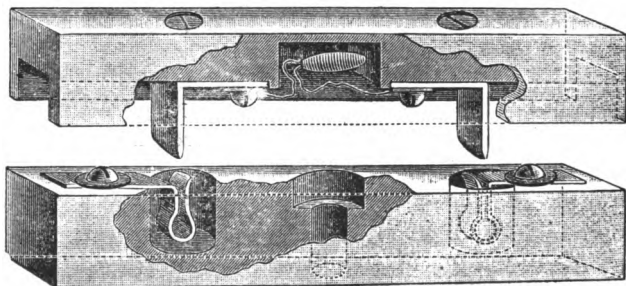

FIG. 41.

them shellaced as soon as they are made up, to prevent the action of the air. German silver, aluminum or copper, make the most reliable fuses. In Fig. 42 is shown a form of lightning arrester, combined with a fuse, which explains itself. A pair of carbon blocks, one connected to the ground plate by a spring clip, and the other connected to the line the same way, a thin strip of mica holding them apart. The mica has two or three holes punched through the centre, and the air in these holes being nearly all expelled as soon as the discharge takes place, it will in this way offer a path of low resistance to the ground as long as the current remains on the line, while the absence of air at these points prevents the carbon from burning up. Carbon does not corrode nor fuse, and as long as it lasts it is always ready for business. There are several forms of lightning arresters made

on this principle, and they constitute the most efficient class I know of. A flash of lightning will, however, sometimes decompose them enough to leave a small amount of dust between the plates; enough in many instances to ground the line. In case of a "ground" of this kind, remove the carbon blocks and wipe or blow the dust away.

As to the necessity for fuses and lightning arresters in cable boxes, practice differs greatly. In some parts of the United States, as on the Pacific coast, lightning arresters are not considered necessary, and the only safeguard is a fuse placed behind

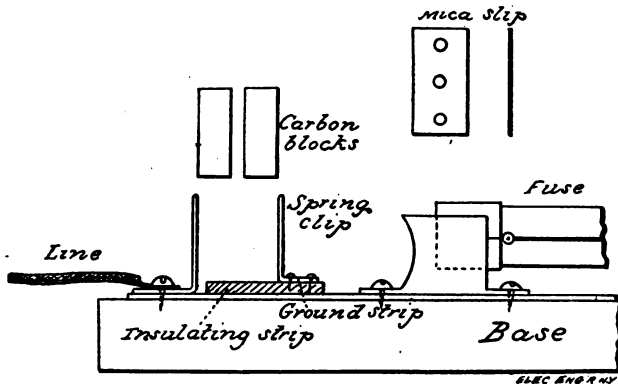

FIG. 42.

the switchboard to protect it against trolley or electric light currents, while in some of the Southern States too many safeguards cannot be used, and even then lightning will sometimes go by them all.

When lightning gets into the cable over a single conductor, the static and inductive resistance of the cable sheath, and the other conductors, especially the one it is paired with, makes a condition that is very liable to break down the insulation between them. If, however, lightning arresters are placed in the terminal box, it will either flash to ground or become so divided among the various conductors as to be practically harm-

less. Even where there are no arresters it will generally spread more or less over all the terminal binding posts.

It is, I think, an open question whether fuses are much of a protection against lightning, for when it has come several feet through the air for the express purpose of visiting an exchange, it will not be stopped by two or three inches of fuse, and before the fuse can possibly cut out, the lightning has gone by and the line has been opened without being afforded any protection.

On the whole I think that the best place for fuses is behind the board or in the cross connecting room, where they can be readily inspected and replaced, and if the insulation of the cable is up to standard the only effect of a trolley current will be to blow the fuse and make the cable noisy, till some one can go out and remove the cause of the trouble. But where lightning is to be feared I would put lightning arresters in the cable box, but without the fuse, for it will have to come fast and furious if the static induction of the cable will not shunt it to the ground strip, but to make sure it would be well to use these arresters in the exchange also. Where a metallic circuit, or common return system is used, it is a good idea to connect the middle or ground post of the subscriber's instrument to ground, the toothed plates generally affording sufficient protection.

In some cities where Underwriters' rules are strictly enforced, the company may be compelled to place a fuse block where the wires enter the subscriber's premises. In that case use a 1 ampere fuse, for one doesn't want a fuse to give way for every little thing that comes along. The inspector may also require porcelain or glass tubes where the wires enter the building.

In concluding I can lay down a few general rules which will produce the most satisfactory results, though they are not to be taken as conclusive.

1. Place lightning arresters with ground strip both in the cable box and in the exchange. If the return wire is grounded or connected to the lead sheath of the cable, connect the ground strip to it by a wire not smaller than No. 10 B. & S. G., or if the common re-

turn is not grounded, connect the ground strip of the arrester by a No. 6 wire to ground at the foot of the pole. It does not matter so far as lightning is concerned whether this ground wire is iron or copper, for Dr. Lodge's experiments would seem to show that possibly iron or steel is even better than copper.

2. If the cable boxes are easily reached and inspected from the exchange, place fuses there; if not, place them behind the cross connecting board. Too many fuses in a circuit are a source of annoyance, and it is better to have a drop burned out occasionally than to have a constantly interrupted service.

3. If the common return is not grounded, a large lightning arrester something like the Wurts non-arcing arrester, made by the Westinghouse Company or the street railway arresters made by the General Electric Co., will be found best adapted to this work. As an additional precaution in this case, it would be well to have a switch connected to a ground wire, so that in a thunderstorm the ground could be thrown in.

CHAPTER XIII.

SELECTION OF INSTRUMENTS.

PROBABLY one of the most perplexing questions that the new exchange management has to face is in regard to the selection of instruments. There are some manufacturers of instruments who are not telephone experts, and in consequence produce instruments that are not perfect by any manner of means; some are fairly good imitators, without possessing the knowledge necessary to successful imitation. They will overlook many important points, but at the same time produce an instrument that is good enough to sell to the inexperienced, and, when, after many months, the buyers' inexperience is succeeded by knowledge he will find that the manufacturers have also learned a thing or two, produced a new form of instrument, and it may be the greenhorn will be caught twice by the same maker. Besides, the newcomer is apt to be caught by low prices, and, I regret to say, competition makes some manufacturers use very inferior material, whereas, successful electrical instruments require correct proportions and good material, and nothing is too good for exchange service. A cheap telephone for exchange work is dear at any price.

Now, this is not to be taken that there are no good telephones made by independent concerns, for there are manufacturers who are doing honest, conscientious work, and trying by every means in their power to produce, and who do produce, as good instruments as are made anywhere, but at the same time purchasers should not always take the first instrument offered them, even under a guarantee, for there are selling agents who will give any kind of a guarantee the purchaser may ask for in order to effect a sale; making the guarantee good is another matter.

The independent manufacturers have not yet brought out anything radically new. Their transmitters seem to be confined to imitation of the Edison and Hunning, which do not possess means of adjustment, and the only adjustment left is to put in more or less carbon until it becomes "about right." If this is carefully done and tests made at the factory, and the carbon is of good quality, there should be no further trouble. But in the haste of getting out orders this is not always properly looked after, and many an instrument is condemned after a brief trial on this account. I have remedied the defects in many a transmitter by changing the quantity of carbon granules.

Another point to be noted in this connection is this: Have your instruments and coils as nearly alike as possible and when you have found an instrument that will do your work, take that as standard, and insist that all others shall follow it, unless changes are made to correspond all round. It does not improve the service to have some induction coils wound to 18 or 20 ohms, some to 125 and some to 250 ohms.

Also remember that the short 250 ohm coil was made for the Blake transmitter, and does not work well with transmitters of the Hunning type, a longer coil being necessary.

We also find buyers who, next to the price, always pay more attention to the outside appearance of an instrument than to its other qualities.

While admitting that the telephone as assembled up to date does not possess the æsthetic qualities one could desire (in fact it could be very materially improved in this respect, and the maker who really succeeds in doing so will score a hit), a utilitarian who has followed up exchange and instrument troubles for two or three years never notices the outside of an instrument at all unless it is a total wreck, his first impulse being to reach down into his pocket for a key and get the box open.

If, upon inspection, the inside shows permanent, substantial work, with contacts that look as though they could be relied upon, with the different circuits properly insulated from each other, with the ringing magnets properly shunted or cut out,

and the general appearance indicating that it has been finished by workmen instead of apprentices, he regards these as a good sign.

Then, if, upon test, the receiver, the coils and the transmitter prove all right, he is disposed to accept it, regardless of its outside appearance. But if, on the other hand, he finds contact springs of cheap German silver or brass with weak and unreliable contact pressure, with no platinum anywhere visible, with solder and acid slobbered all around the inside of the box, with magnets looking rusty and cheap, with insulation looking as though it might break down at any time, with bell magnets in series with the talking circuit, and the wiring in such a shape as to be almost impossible of access, he knows that he will have trouble with that instrument from the very start, and no amount of gingerbread work on the outside can possibly redeem it, in his estimation.

I can recall the case of one company having a transmitter which, while new, will show up in fine shape, but in actual use develops troubles of the most aggravating nature, because their instrument wiring is out of reach and seems to have been designed and carried out by boys who were more used to making cheap call bells than anything else.

Suppose we study this question of contact springs. There seems to be an idea that because copper or brass is used in electric light switches and to a great extent in cheap call bells that it will also do for the telephone hook switch, forgetting that the contact on the smallest electric light switches covers several times the area and has many times the pressure of any telephone contacts.

In this connection it may not be amiss to tell a story of an experiment of the author's younger days.

The object of the experiment was to find out how long certain batteries would last on a continuously working circuit, which, however, was lost sight of in the experiments that followed. Not having a bell handy (for bells could not be bought for 20 cents apiece in those days) he made up a coil and magnet of

his own, using wire enough to give a resistance of about two ohms. The apparatus, shown in Fig. 43, is crude, of course, but it was good enough for the purpose. The armature (A) was simply an old nail filed down and the spring contact on it (S) was of ordinary brass. The back contact (N) was a wire nail, to which one side of the battery was connected, the armature being pulled back by a rubber band (B), the whole being connected to four cells of battery. Owing to the large size of core used, there was considerable sparking at the contacts between S and N. With this amount of battery

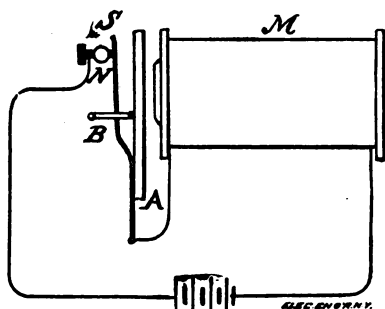

FIG. 43.

there was lively action at the start, but it soon stopped. As the battery did not present a run-down appearance, a search was begun for the cause, when a touch on the armature caused it to start again, only to stop again in a short time. This time an examination was made of the contacts, and it was found that they had blackened considerably. They were rubbed with sandpaper and the rubber band tightened to increase the back pressure, but with the same result as before.

This time there was a change of metals at the contacts and before the experiment was finished about every metal was tried to insure a reliable contact, with the same result, until a piece of carbon took the place of the nail (N) and a piece of silver to the strip (S), after which the service was fairly constant, but even

the silver would blacken and cut out after long use, till finally a piece of platinum was secured, which stopped all further trouble, though two pieces of hard carbon would most likely have worked well also. Now, of course, all contacts do not spark as badly as that one did, but the lesson was well worth learning, and has never been forgotten.

Moral.—See that all contacts are made of platinum, or else that a strong rubbing contact is had, for a strong rubbing contact will clean itself to a limited extent.

Look into one of the latest Bell instruments with, say, a Blake transmitter. Notice that the contacts on the diaphragm are platinum and carbon. The switch hook contacts are platinum altogether, yet even they get dirty once in a while; then notice how the door hinges are connected by a spring with soldered contacts and see how neatly the wiring is all done and how easy of access in case of trouble. Go into a telegraph office and examine the operator's key. There is a hard rubbing contact, yet in standard instruments you will see nothing but platinum points.

Of course, platinum is costly and there are switches made without it that do fairly well, and there are manufacturers who can make as good instruments as the Bell, or even better than the one with the Blake transmitter, and these points are merely mentioned to guide purchasers in their selection.

CHAPTER XIV.

THE TRANSMITTER.

THE first thing I should do after an examination of the switches, generator and ringing apparatus would be to take the transmitter apart. The tendency among many manufacturers of telephones has been to make the transmitter diaphragm too small, which is theoretically wrong; and another is to spread the granulated carbon out over the whole back side of it, which is wrong again; and the fact that some of these have attained a fair measure of success, does not prove that the theory is wrong, but rather that the small variations of current used in telephone practice will be transmitted in spite of inefficient appliances.

Some makers are already beginning to find this out, and we find the carbon diaphragm constantly getting larger and the back plate for holding the granules getting smaller, while others have abandoned the carbon diaphragm altogether, using a thin sheet metal in its place, producing a transmitter which talks and acts much like the American Bell solid back, which has been the most powerful and efficient instrument in the recent past; and we may add, has never been excelled in commercial practice except by those mechanical contrivances known as the acoustic telephone, which had a diaphragm at least six inches across. Up to their limit—which is about two miles—these possessed a perfection in transmitting conversation which has never been possessed by their electric rivals, and while their troubles were many and various, no electrical instrument on the market has enabled people to carry on a conversation with other persons from all parts of an ordinary room.

Were it not for the fact that it is so sensitive to weather changes, parchment, which was largely used in these instru-

ments, would be an ideal material for both transmitter and receiver diaphragms; but even when covered with shellac it would require considerable attention and adjustment. Even carbon has its faults, one being its porosity, which allows dampness from the breath to work through to the granules on the back side, and most of the "packing" in the Hunnings type of transmitter comes from this cause, the moisture causing the granules to stick together.

Some makers cover the front of the diaphragm with varnish, which is a very good way, and some use a thin layer of oiled silk or mica, which, it seems to me, must have a slight muffling effect, though by taking pains with other parts of the instrument they get good results in spite of it.

This quality of carbon has led some manufacturers to the use of steel in their diaphragms, which has not this objection, and which is very sensitive to sound waves, though it has a metallic tone, which is objectionable.

The size of the diaphragm is of more importance than at first appears, for, in the most powerful transmitters, the free swinging surface of the diaphragm has a diameter of about three inches, and if I were manufacturing telephones I should experiment with still larger sizes. One of the best telephones I ever talked over had a cork diaphragm and a vibrating surface of about six inches. One manufacturer to whom I spoke in regard to this referred to the damper spring used on all Bell instruments to prevent too free a vibration, but this is simply used to prevent the resonance of the steel diaphragm, and is always used with a cushion of soft rubber; and every instrument man knows that should this rubber become worn out or brittle, or the spring a little too tight, that the conversation weakens proportionately. Those who have studied acoustic and musical instruments understand this perfectly.

Our present knowledge of vibrating surfaces indicates that the diaphragm vibrates as a whole, as shown by Figs. 44, 45, 46 and 47. A glance will suffice to show that in order to swing freely the edges of the diaphragm should not only move freely, but

that the range of greatest variation between the diaphragm and back contacts would be at the centre (B). In Fig. 45 notice how the vibration is reduced by having the edges tightly clamped, and in Fig. 46 the difference between a small one and the one shown in Fig. 44. Even if the diaphragm vibrates in nodes, as shown in Fig. 47, the centre is still the most important part, and

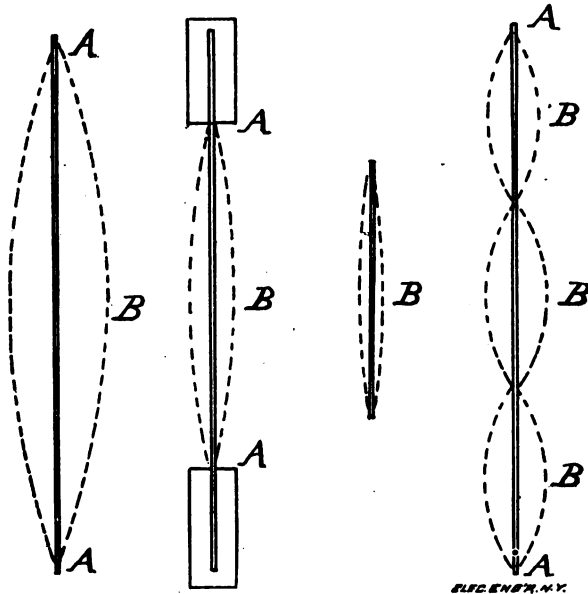

FIGS. 44, 45, 46 AND 47.

carbon granules placed all the way up and down the width of this surface only retard its movements, and the battery variation caused by the movement at the centre may be almost completely neutralized by the comparatively stationary carbon at the edges.

In the instruments known as the "solid back" there is a small

button fastened to the centre at B, which still further assists in swinging this centre to and fro.

Of course, there is such a thing as too free a vibration, in which case we would get loudness, at the expense of clearness, and this explains in a measure why the long-distance telephone is sometimes heard more distinctly at two or three hundred miles than when used for local business. In the former case the lighter over-tones, which have a tendency to jumble and confuse the articulation on short lines, are eliminated by the longer line resistance, which, while leaving the articulate sounds somewhat weaker, also frees itself from the objectionable ones. The form of the mouthpiece also has more to do with the talking qualities of a transmitter than is generally supposed. It should not lie too close to the diaphragm, as the back pressure of the air in the confined space would muffle it, nor should there be too much space, as much of the concentration effected by the mouthpiece would be lost.

CHAPTER XV.

THE INDUCTION COIL.

THE purpose of the induction coil is to raise the battery power of the one or two cells, used for the transmitter, of from 1.5 to 3 volts, to a much higher pressure, in order to overcome the resistance of long lines. A small amount of current at a high pressure will do the same amount of work as a larger current at a lower pressure, exactly as a transformer does in electric lighting. For example, in long distance power transmission by alternating currents the pressure is from 10,000 to 30,000 volts. Now, no machine would be safe at this terrific pressure. Instead then of generating this high pressure the machine delivers a powerful current at a pressure not to exceed 3,000 volts, and more frequently 300 when it is changed or stepped up, by means of a transformer. This is simply a form of induction coil, wound to give the necessary voltage (pressure) for long distance transmission, and the current is transformed back again to 100 or 500 volts for lighting and power at the other end. Thus we see that the same kind of an induction coil (transformer) can be used to step the current either up or down, as may be required.

This stepping up and down always increases or decreases the quantity of current in inverse ratio to the voltage, minus, of course, a small amount lost in transformation. Thus a transformer, whose ratio is 20 to 1, which is commonly used in electric lighting, may take in a current of only 10 amperes on one side, at a pressure of 2,000 volts, coming out on the other side at a pressure of only 100 volts, while the current has risen from 10 amperes to nearly 200.

All induction coils and transformers will work either way; first, to raise the pressure and decrease the current; or, second,

to raise the current and decrease the pressure, as shown in Fig. 48, and it will be noticed by a comparison of the lines that the power remains the same in both cases. That is, theoretically; practically, there is a loss of from 3 to 50 per cent. Telephone induction coils, wound to a proportion of 500 to 1, which is commonly used with the Blake transmitter, will raise the battery voltage to more than 1,000 volts, but the quantity of current has become so small and the alternations are so rapid that it cannot be felt if taken through the body; because at this ratio a current of 1 ampere in the primary circuit becomes less than

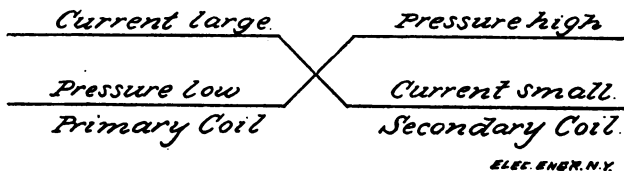

FIG. 48.

.002 of an ampere in the secondary, and yet this is several times the amount used even in long distance instruments.

It may be of interest to note that in one of Dr. Wietlisbach's experiments the secondary current from a Blake transmitter over a resistance of 1,000 ohms was .000547 ampere. Prof. Cross, with a resistance of 400 ohms and 512 vibrations per second, obtained from three different instruments, using Blake, Edison and Hunning's transmitters, currents ranging from .000072 to .000556 ampere, the windings of the coils not being given. The small amount of current used shows the extreme sensitiveness of the telephone receiver.

A PRIMARY LESSON.

Most of our readers understand something about this subject of induction coils, and yet there are some well-informed telephone men who need to review it occasionally. The best training in telephone work is a course of study in alternating currents, as applied to power and lighting, because these currents being

larger and the alternations (reversals) less rapid, their effects and peculiarities can be studied more closely, and a great many things which puzzle the man who knows nothing but telephone work, become plain to the one who has studied the former.¹

While the induction coil may be constructed in a variety of ways and possess any shape or size which will give the correct transformation, the most common form employed in telephone work is the one shown in Fig. 49, in which the primary is

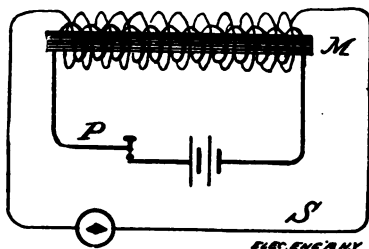

FIG. 49.

wound in a comparatively small number of turns around the iron core, and the secondary, with a larger number, wound outside. In order that the battery pressure may be increased when connected to the primary, it is necessary that the secondary winding should have a great many more turns, and in order to bring it as near to the iron core as possible the wire is a great deal smaller, usually about No. 36 or No. 40, and, of course, its resistance is much higher. Now this resistance is not a virtue, for we would prefer to do without it if we could; but in order that the sound waves may not be distorted too much, the iron core must not exceed a certain size, say, 4 inches in length, and as the primary coil is wound on the spool with from 100 to 200 turns, and the secondary from 3,000 to 5,000 turns, it is easy to see that it must be very small to keep it within the space allotted to it, and small wire means high resistance.

¹Those who wish to follow this subject further may refer to the following books: *The Alternate Current Transformer in Theory and Practice*, Vol. I., by A. J. Fleming; *Handbook on the Telephone*, by Preece and Stubbs, and *Theory of Telephonic Transmission*, by Dr. V. Wietlisbach.

The fashion of designating coils by their resistance really means very little to the electrical engineer, who would use the expression ampere or milliampere (turns), which means the number of turns necessary to produce one ampere (or milliampere, as the case may be), of current.

Designating coils by their resistance came down to us from the days when telegraph instruments and electric bells were the only electrical instruments manufactured, and electrical units were an unknown quantity. Thus, to a manufacturer who used nothing but No. 36 wire for winding his relays, a certain number of ohms really meant a certain number of turns. These proportions are a matter of considerable importance, and in order to obtain good service they should all be as nearly alike as possible, as coils of the same size, winding and resistance will help each other out.

According to experiments made by W. H. Preece, the most successful coil for all-around work up to 50 miles, was a coil with a resistance of .5 ohm in the primary and 250 ohms in the secondary, and the best coils yet found for local business, at least in connection with the Blake transmitter, have about this proportion.

On measuring up about a dozen instruments recently, some of the latest the Bell Co. have sent out of the Blake pattern, I found the resistance of the primary coil measured through the switch to average .8 ohm (though one was found as low as .27 ohm), with the secondary coil measuring from 250 to 260 ohms, and the Blake transmitter button, with a rather loose adjustment, varying from 2.29 to 4.4 ohms. These instruments were as satisfactory a lot of Blake instruments as the Bell Co. ever turned out, which led me to think they had struck about the right proportion. With the Long Distance, solid back instruments, however, the case was different, the resistance of the transmitter being from 12 to 30 ohms, which required, of course, two powerful Fuller cells and a larger coil, it measuring $4\frac{1}{2}$ inches long, the primary winding measuring 1.5 to 2 ohms and the secondary from 18 to 19 ohms.

Of course it must be remembered that a loose carbon contact is quite an uncertain factor, but still it comes near enough for comparisons to be made, and some of the most successful independent instruments showed similar results.

One American Electric solid back transmitter showed good results with a coil about $4\frac{1}{2}$ inches long with secondary resistance of 220 ohms, while another good talker, an old style Kokomo Hunning, has a secondary of 230 ohms (long coil), and a primary circuit of 15 ohms, including the transmitter.

This high resistance of the Hunning, or any granulated carbon transmitter, makes two or more cells of battery necessary in order to give the proper magnetizing force to the primary coil. But too many turns means sluggish action in the coil, and therefore the winding in the primary should not exceed 1.5 ohms, with, say, a winding of perhaps 225 ohms in the secondary; but whatever coil is adopted, take that as standard, and make other coils conform to it.

If a coil is too small, we have clear articulation, but very weak sounds. If the coil is too large, we have loudness at the expense of clearness, and sound waves are so complicated in character that it is a constant source of wonder to the electrical engineer that they are transmitted at all.

In currents used for lighting and power, it is the aim of the dynamo builder to so balance his coils that the resultant waves will come in the form of a sine curve (Fig. 50) in which the current starts at zero, rises to a maximum at B, falling to zero again at C, then repeating the performance in the opposite direction. Such a curve can be transmitted further with less loss, than any other; and the more a wave departs from this form the greater the distortion from resistance, self-induction, retardation, etc. An example of this can be seen in the way cable messages are received across the ocean. In crossing the ocean the rising and falling lines, as made by the siphon recorder, encounter so much wave distortion that they could not be distinguished, except by an operator used to these peculiarities, the difficulty increasing

with the speed; for the higher the speed the greater the wave distortion. But the highest cable speed hardly means more than from 3 to 10 impulses per second, while a telephone has to take from 200 to 2,000 per second, and besides the telephone wave is not a sine curve as shown in Fig. 50, nor a series of distinct impulses as in a cable message, for if it were, telephonic

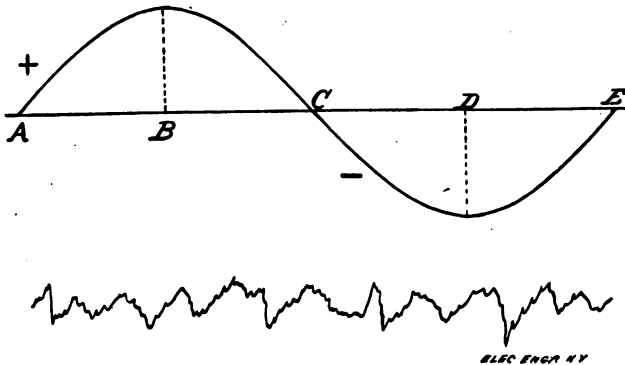

FIGS. 50 AND 51

ELEC ENGR NY

transmission would be an easier problem. Besides it is pretty well known that pure musical tones can be transmitted much further than articulate speech, because musical tones more nearly represent a sine curve. Articulate speech is so loaded down with overtones that the curve looks more like that shown in Fig. 51, and yet in spite of all this, every one of these is reproduced if the line is not too long.

CHAPTER XVI.

THE RECEIVER.

TELEPHONE receivers have not departed greatly from the standard Bell type, except that there is quite a difference in the quality of the material of which they are made. The best quality of steel for example will hold its magnetism for a long period of years; while I have run across some which were worthless in a few months.

I know of one manufacturer who uses steel that costs about 80 cents a pound for his receivers. It is unnecessary to say that his receivers are not sold for 50 cents apiece, and he has customers who have an idea that first cost isn't everything, and that people who buy instruments of him do not have to replace them in a year or so. Good electrical instruments require first-class workmanship and first-class materials, which recalls the advice of Dr. F. B. Crocker in regard to dynamos that "a poorly finished machine is apt to be very inefficient," or something to that effect, possibly because the manufacturer who uses first-class material and good workmen, will also spend the slight amount necessary to give it a good finish.

There is a tendency now among many manufacturers to use receivers of the bipolar type, and some of the latest put out by the Bell company are of this pattern for use in connection with their long distance instruments.

There is also a disposition among some of them, to make the case partly of metal. I do not think this is a good idea for the reason that the person using it is liable to shocks during a storm and this evil is by no means imaginary, as any experienced operator can certify. It is useless to caution people against using a telephone during a thunder storm, for an exchange which has been quiet all day may suddenly receive a large number of calls upon the approach of a storm, and it is

precisely in such emergencies as this that the telephone proves its convenience, and with the many protective devices at our command, there is no need of shutting down an exchange during a storm, or exposing patrons to disagreeable shocks. An exchange should always be ready for business, and every safeguard provided to inspire public confidence. Let, for instance, some newspaper publish an account of a person killed, or shocked, while using a telephone. Hundreds of people read that item and thereafter they cannot be persuaded that a telephone does not "draw lightning."

One company in Cleveland, Ohio, and another in Chicago has gone to the other extreme and constructed a receiver in which even the cord tips are covered by the hard rubber case and no metal of any kind is outside; the receiver is of the bipolar type; and taken altogether it is as good as any I have ever seen.

The present practice is generally, to wind the receivers to a resistance of from 75 to 80 ohms, though one or two companies wind them as high as 175 ohms, which gives them a very powerful action, but they have to use a very heavy diaphragm, so that I really cannot see what is gained by it. Besides, as the receiver is connected in series with the line, it seems to me that the extra number of turns and greatly increased resistance and self-induction are a detriment, but it may be that the extra power thus gained will more than offset this feature.

I wonder if anyone has ever tried a receiver wound to 1,000 ohms and bridged across the line terminals?

INSTRUMENT SPECIFICATIONS. I.—WIRING.

The wiring to be as much as possible in plain sight, and all of it readily accessible, and the wiring of the generator box and transmitter should be so arranged, that they can be readily taken apart for inspection and repairs.

Contacts between different parts of the instrument, as between the transmitter and magneto box, must be made through binding posts with machine threads and screws so that they can be readily disconnected; and contacts made under wood

screws and washers, will not be approved unless such contacts are never likely to be disturbed and in addition are soldered.

No wires to go on the back of the backboard except the two leading from the battery to the switch and induction coil.

Induction coils and other parts must be so placed as to be readily accessible for inspection and repairs.

The induction coil must not be placed in the base of the transmitter arm or so placed that the entire transmitter would have to be disconnected in order to get at it, as these coils frequently get out of order.

Wiring contacts in the magneto box and transmitter should be soldered as far as practicable, especially those in contact with the binding screws, leaving the connecting wires only to be brought under the screw.

No wires in the box to be coiled or "pig-tailed," except those connecting wires which are liable to be disconnected for tests, etc.

II.—MISCELLANEOUS.

The switch must have firm rubbing contacts, and preference will be given to those having platinum at such contacts.

The ringing coils should have a resistance of 250 ohms or more and must be so connected to the switch as to be entirely cut out, or short circuited, when the hook is up.

The generator—for ordinary exchange instruments—should ring clearly through a non-inductive resistance of 10,000 ohms, and the armature should preferably be "built up" of laminated plates. Where bridging bells are used the generator should also give current enough to ring them all in the heaviest circuit, including the line resistance.

III.—TRANSMITTERS.

Transmitters should be of the Hunning type and constructed as follows:

The disk to have a free swinging surface of at least 3 inches.

The resistance to be as nearly as possible from 15 to 18 ohms, or less. Where granulated carbon presses against the disc, the

area of contact not to exceed a square or circular space of $\frac{3}{4}$ -inch in diameter. This also applies to transmitters of the "ball" type.

Any screws used to hold the carbon block to the arm should be insulated from the granules, unless specially intended to transmit part of the current; but it is better to have the current pass from the disk through the granules and to the plate directly, without going through any other conductor than the carbon, as an exposed screw in the base of the carbon block has a tendency to make the transmitter uncertain in its action.

The carbon disk should be electroplated on the front side and contact with the battery made by means of a fine wire soldered thereto.

The induction coil to be four inches in length, and the iron core to consist of a bundle of fine, soft iron wires, laid longitudinally, not to exceed 5-16 inch in diameter, the iron wires composing the bundle not to be larger than 22 B. & S. in size.

The primary coil to be wound to a resistance of 1.5 ohms, and the secondary to 225 ohms, the winding to be as nearly uniform as possible, the difference between any two coils not to exceed 4 per cent.

It is important that all induction coils, as well as receivers, should be exactly alike to secure the best results. An ideal plant would have these coils so nearly alike, that, if connected to a differential galvanometer the needle would stand in the centre. This perfection of coils is not easily obtainable at present, but it will be reached some day.

(The requirements as to the secondary winding may be varied according to circumstances, but whatever winding is decided upon, make all the others conform to it).

There should also be a spring washer in the hinge of the arm, to insure a reliable battery contact at this point. (The author has traced a great deal of trouble in the battery circuit to this hinge). A better way is to use a duplex cord to the transmitter.

To get good results the battery used with this transmitter should deliver .2 of an ampere through the transmitter, switch and coil.

It will be noticed above that preference is given to the Hunning type of transmitter, not because it is the best, for I regard it as a rather inefficient one, but because it is free from patent litigation, if any of them are, and if properly made will do good service, and needs no adjustment or repairs while in ordinary use. One of the objections to it is its high resistance, which cuts down the battery current while the mass of carbon granules is not as sensitive to slight variations as the old-fashioned Blake, so that voices cannot be so readily recognized. Were it not for the fact that on account of blackening at the contacts the use of the Blake is restricted to a single cell of battery, it would be an ideal transmitter for either short or long distance work.

The modification of the Hunning, known as the "solid back," is an improvement, but care should be taken to avoid detail patents.

One company in Marietta, Pa., cuts down the resistance of the carbon granules by plating them with gold and silver. This bi-metallic combination should make a powerful talking instrument provided that experience shows that the granules do not oxidize. In order to get the best results I should think the granules might be mixed with those of ordinary carbon in, say, equal parts.

CHAPTER XVII.

INSTRUMENT AND LINE TROUBLES.

It is to be supposed that every lineman knows how to "hunt trouble," but one or two hints may not be amiss.

In open lines it is best to first go on the line and listen, for any telephone man who knows his instruments and lines, can tell by listening, and blowing gently on the transmitter, about how far off his trouble is, either on grounded or open lines.

Thus, in an open line, if the line is "dead," with not a particle of escape or induction coming back to the ear, he knows that the trouble is nearby, and acts accordingly. If, however, he can hear a slight inductive disturbance, he knows that it is outside of the office cables, or a quarter or half a mile away, and familiarity with the exchange and the instruments in use will enable him to guess very closely as to where the trouble is.

All lines, however, will not act in the same way. Thus, lines running through trees will act differently from those that are well insulated, and those alongside of a trolley road will be more noisy than those in other parts of the town; but practice will enable him to tell the difference.

With grounded lines the case is reversed. If the transmitter comes up loud and clear, without any induction, the trouble is nearby, and the amount of induction on the line is in proportion to the distance. This method also requires practice.

In New York City in the early days when there were hundreds of housetop fixtures, there were men so expert in this kind of a thing that they could almost walk to the block where the trouble was located, and as climbing onto six-story buildings took time, a man was judged very largely by his ability to clear trouble with the least amount of work.

What is known as "resistance trouble" is caused either by a loose connection which will be indicated by the lines opening at

intervals, or by insufficient contact, which makes the conversation have a very faint, far-away sound, as when a joint is made in rusty or badly corroded wire without cleaning. To locate this trouble generally requires the services of two men, one to listen and make tests, while the other goes along the line to the points directed.

In the first place short circuit the subscriber's instrument, and if the transmitter "comes up" loud and clear, it is plain that the fault is outside. Next try another short circuit, or ground,

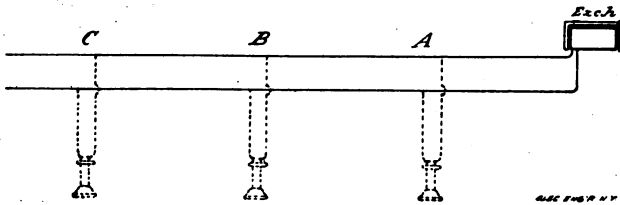

FIG. 52.

outside the subscriber's premises, and try the instrument again, which will show whether or not the house wiring is all right.

Then let the second man start, either at the exchange or the sub-instrument, as shown in Fig. 52, and move from point to point, as at A, B, C, until the trouble is located between two points, when the range may be narrowed down, meanwhile carefully examining all connections, until the bad one is found. The second man may use a telephone and listen himself, or he may merely short circuit, or ground the line, depending upon the first man for information as to results. Of course if the line is grounded or short circuited, the first man must depend upon his skill in listening, to locate the trouble.

A loose connection is sometimes hard to catch owing to the fact that it may not show up for days, then suddenly open up without warning, only to appear all right again when the trouble

man tests it, and in this way keeps the office force "guessing" for a week or two.

This trouble is often found in the switch hook, and for this reason always test the instrument first.

It is also frequently found in cable and office terminals that a loose screw or unsoldered tip is the cause. It will sometimes be found in a faulty switch cord, or a dirty spring jack; or in the secondary winding of the induction coil, and in some instruments where the line circuit goes through the generator shaft, it may be found from loose or dirty springs at that place.

In some switchboards where the drop is left in circuit, it may also be found there, especially after a thunderstorm or a visitation by other foreign currents.

Therefore, while there is a chance that this trouble may be in the line, there are several chances that it may be in the instrument, switchboard, or distributing board, and these should be tested first.

In some of the new exchanges a great deal of trouble can be traced to the excessive use of fuses in the line.

In one exchange there were fuses at both cable terminals, and still another in the instrument. This, of course, protected both instruments and board very thoroughly, but the annoyance and trouble from this batch of sensitive fuses cost the company many times the price of an occasional drop.

Three fuses in the line are enough, two at the distributing board (both sides of the circuit) and one at the instrument, which should satisfy the most exacting insurance inspector and afford all needed protection. Of course, as explained in a preceding chapter, ground arresters can be placed wherever desired.

The first thing a trouble man should do is to become familiar with the instruments in use, and for testing purposes the ordinary instruments may be divided into four parts:

1st. The generator circuit. If in trouble, will not ring the exchange, though the bells can be rung from there. Remedy: Test by placing a finger and thumb on terminals nearest

the armature coil, turn the handle and "feel" for current. Most magneto generators have a movable shaft which, when the handle is turned, is pushed over against a spring contact which puts the generator to line. Trouble is often found here.

2d. The ringing circuit. This includes the bells and the "down" contacts of the switch. Trouble: Does not ring, though the generator may, or may not, ring the exchange. Remedy: Open one side of the bell magnet circuit, then turn the handle and "feel" for current, placing the thumb and finger so as to shunt the bell magnets. If the current comes up all right the trouble is with the magnet spools, for it can't be anywhere else. If this test shows a strong current, place the thumb and finger in series with the spools and in this way find out whether it is an "open" or short circuit. In some instruments the frame of the bell is connected in circuit so that another "ground" on the frame would cut the bells out and this will often be found in the wire ends joining the two spools together getting in contact with the frame. If no current, however, is obtained in this test, examine the switch contacts and test back toward the generator.

3d. The secondary circuit. This includes the secondary coil, and in most cases an up-switch contact, receiver, cord and line. Trouble: Does not talk, though it can ring the exchange or be called from there, but so far as talking or hearing is concerned, the line is "dead." Remedy: Examine the contacts, test cord, receiver and coil, till the trouble is found.

Note: In some cases the receiver is left in series with the ringing coils when the hook is down, in which case it cannot be included in this circuit, as a broken cord opens the whole line.

4th. The primary or transmitter circuit which includes the battery, the transmitter, the primary coil, and the up-switch contacts. Trouble: Can call the exchange and hear perfectly, but cannot be made to talk. Remedy: Examine carefully the battery and wires leading to the coil and transmitter. Take a hand telephone and, beginning at the battery, follow up the circuit

as long as the battery clicks, until the trouble is located. Sometimes a cross between the primary and secondary coils will produce this effect.

The first and second sections of the above apply only to those instruments in which the ringer coils are in series with the line. There are other instruments with direct current instead of alternating generators, or with the ringer coils bridged across the line instead of in series.

In such a case insist on having a diagram from the manufacturer, or else take the instrument and study it till thoroughly familiar with it, following out the divisions indicated above.

Sometimes a transmitter will not talk well from having too much or too little carbon in it.

In order to test this, blow your breath gently across the edge of the mouthpiece and into the transmitter, and when the sound breaks very slightly, the transmitter is as nearly right as you will get it, and a little practice will enable you to test very accurately and rapidly. Beware of too tight an adjustment if you would get good results.

I have seen transmitters so full of granulated carbon that the only way they could be made to talk was to rest the point of the chin against the mouthpiece so that the direct vibration from the vocal organs (the chin is not exactly a vocal organ, but it is connected directly with them and vibrates when speaking) might shake up the mass.

OTHER ITEMS.

It is not a good plan to put two or more telephones in series on a single line, as the self-induction of the magnets raises the resistance of the line to many times the measured resistance of their coils. (To test this matter, it is very easy to perform a simple experiment. Thus, in a transmitter coil whose self-induction is as low as it is possible to get a coil containing iron, the resistance of the coil will be more than doubled by talking into the transmitter. When it does this with a few turns around a bundle of soft iron wires, what will it do when passing around a solid polarized core wound with a large number of

turns? Try to talk through a 1,000 ohm bell in series and note the result, remembering that a good telephone will talk through 50,000 ohms of non-inductive resistance.) A better plan is to buy instruments with 1,000 ohm coils and bridge in on the line, and party lines should be limited to six telephones at the outside, and four would be better still.

In cutting in an auxiliary bell, do not loop it in on the main line, as you will then have it in series when the line is in use. Instead, loop it in on the bell circuit, by bringing the wires inside the box and cutting the bell loop between the right hand binding post and bell. By doing this you will have the auxiliary bell cut out, or shunted, when the hook is up.

This rule also applies to drops used for this purpose. With bridged bells where it is thought necessary to bridge in with a 1,000 ohm auxiliary drop or bell, bring the wire inside the box and bridge across the bell loop, that is, if the bell loop is cut out during conversation.

A 100 ohm drop will generally work in series with a 1,000 ohm bell, however, as the exchange generator will easily furnish current for both.

In connecting telephones in multiple or bridged form, it is a matter of some importance that the generator is able to ring them all clearly, and the only way to do this is to connect several of them together in the shop and try them there; in this case the generator should be tried on nearly twice as many as it will have to ring in practice, in order to balance line resistance, etc.

There is many a generator that will ring one bell through 40,000 ohms resistance, which would not ring four bells in multiple through 1,000 ohms of line resistance, because while the voltage is high the current is very small, and it should, in this case, be tested on at least eight instruments in the shop.

The number of bells a generator will ring depends largely upon the number and size of the magnets and the winding of the armature. Large currents require large magnets.

CHAPTER XVIII.

SWITCHBOARDS.

THERE is doubt in some quarters whether ring-off drops can at present be used by independent exchanges; but they are not really necessary, as a non-inductive resistance can easily be shunted around them so that while the drop is still in circuit it will have no perceptible effect on the conversation.

One way in which this can be done is shown in Fig. 53. The line coming into the board is shunted to the jacks P P, thence to the drops D D, after which it is joined to the common return or ground wire G.

As will be seen, the cords are connected together through a non-inductive resistance, R, which shunts the larger part of the current around the drops, but leaving enough to ring off with. For ringing and listening the jacks may be movable or regular ringing and listening keys placed on the table in front of the operator. These coils should be of high resistance.

Another plan sometimes used is to have switchboard coils of 1,000 ohms each and have them bridged on the line leaving them in circuit for ringing off.

Those who prefer switchboards used by the Bell companies can procure them from the Sterling Electric Co., of Chicago.

In switchboards of this kind (shunted and bridged) there is liable, however, to be considerable cross talk from the close proximity of the coils to each other, which would be absent if they could be cut out, but this can be avoided by the use of an iron shield which entirely surrounds it, thus screening the inductive effects (Fig. 54). The oldest of these is the tubular shield, the invention of Mr. Frank B. Cook, which entirely surrounds the spool, and is simply a soft iron tube of about No. 16 B. W. G. in thickness. Another form designed to evade this patent and apparently as efficient, is a shield made of half

a tube, placed above the magnet spool, and covering fully half of it. Placed in rows, as they are, each drop is shielded from the one either above or below it.

Others have tried wrapping the coil with ordinary tin plate, but this is hardly enough, unless there are several turns. The back of the board might also be made up in squares like boxes in a post-office, and each drop placed in its own separate box.

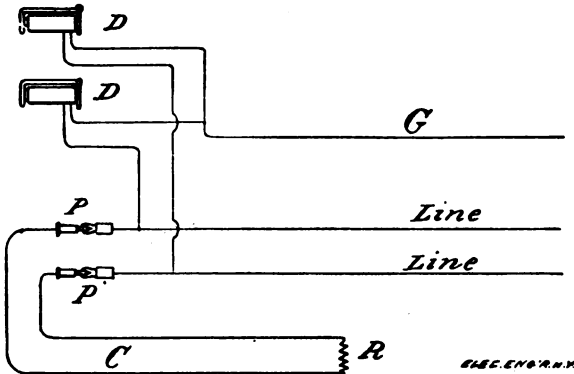

FIG. 53.

This little matter does not seem very important, yet as many of the new exchanges are badly troubled with cross-talk, and as most of it can be traced to the switch and cross-connecting boards, it will be seen that it is a little detail worth attending to.

One of the most frequent causes of switchboard trouble are the cords; as the perfect plug for holding the ends of these cords has not yet been invented, the only thing to do is to caution the operators not to pull on the cord in removing plugs, but to always catch the handle.

In some boards, too, the plug rests on a ground plate so that in answering calls, the operator merely has to plug in. If the plate contact, however, is made through a collar at the base of the plug, there is liable to be unsatisfactory service

owing to dust and loose connection between this collar and the ground plate.

BATTERIES.

For ordinary telephone work batteries of the sal-ammoniac type are the best, as they are cleaner, less troublesome and last longer than any other.

By sal-ammoniac cells are meant such cells as the carbon cylinder, or Leclanche, in their various forms, in which carbon combined with manganese, zinc and a sal-ammoniac solution are used.

The oldest, most costly and least efficient of these is the Leclanche porous cup cell, as it has a higher internal resistance, makes more trouble from creeping salts and is shorter lived than any of the carbon cylinder kind.

Most of the independent companies have found this out and

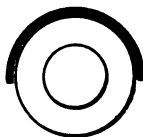
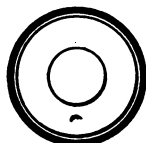

FIG. 54.

ELECTRICAL

have left it in sole possession of the Bell companies, whose reason for continuing its use is something of a mystery. I have never seen this battery used in places where a Samson, Laclede, or battery of similar type wouldn't do even better.

The main thing in a telephone battery is to get one that will last as long as possible with the least amount of attention. In order to prevent evaporation it should have a closed cover. I have known cells of this kind to last a year without any attention whatever, which cannot be said of any Leclanche cell I have ever seen. In well regulated exchanges, however, some one should make a practice of visiting, inspecting and testing every instrument at least once every six weeks, taking particular note of the batteries.

The internal resistance of batteries is a matter of less consequence than the number of volts they produce, as the current going through the primary circuit is nearly always less than .25 of an ampere.

The best battery for the operator's instrument is the old-fashioned crowfoot gravity cell, because in this case the transmitter is in circuit all the time and they are the only kind that can be relied upon for constant long continued work. On the ordinary granulated transmitter four cells is about the right thing.

With toll line instruments a battery giving a higher electromotive force is desirable, and the standard Fuller cell fulfils the requirements more nearly than any other.

The American Bell company lays down the following rule: "When used in connection with long distance lines, it is recommended that a battery be used which will, at all times, give a current of more than .42 of an ampere at the end of one minute after the battery has been disconnected from the transmitter and connected in circuit with an ammeter and a resistance of five (5) ohms."

It will be noticed that this is the minimum current allowed and as they usually prescribe two of these cells, they can easily get double the amount of current specified.

This cell is set up in a 6 in. x 8 in. jar, and is made up of two solutions. The porous cup in the centre contains a strong solution of salt and water with about a teaspoonful of quick-silver added and also contains the zinc.

In the outer jar, which contains the carbon, is used electro-poin, or the fluid made according to the following formula:

Solution for Outer Jar.

Sodium bichromate.....	170 grams (6 oz.)
Sulphuric acid.....	492 grams (17.3 oz.)
Water (soft).....	1,600 c.c. (56.5 oz.)

Dissolve first the sodium bichromate in the water, and then add, very gradually, the sulphuric acid. To prevent overheating, the jar should be surrounded with cold water. If the solu-

tion is mixed direct in the 6 in. x 8 in. jar, see to it that the jar does not rest on a wet board or metal sink.

The following represents the approximate current, resistance and e. m. f. of the different batteries, which the Globe Carbon Works will guarantee, and other firms will doubtless do the same, if asked:

	E. M. F.	C.	Int. R.
Carbon cylinder pencil, zinc	1.5 ¹	1.5	1 ¹
Carbon cylinder circular, zinc	1.55	6	.26
Leclanche porous cup	1.5	1	1.5 ¹
Crowfoot, gravity	1	5 ¹	.2
Standard, Fuller	2.2	5	.44
Globe carbon dry cell	1.6	12	.15 ¹

As said before, however, the internal resistance does not count so much on the average transmitter as the e. m. f.

For example, take the carbon dry cell, which shows a current of 12 amperes with an internal resistance of only .15 of an ohm on a transmitter having a resistance of 18 ohms, a coil, let us say, of 1 ohm. Using two cells we have then:

Internal resistance3 ohm
Transmitter circuit	19 ohms
E. m. f.	3.2 volts
Current, $3.2 \div 19.3 =$16 ampere

Taking the Fuller cell, which has three times the internal resistance and only half the current on short circuit, we have:

Internal resistance9
Transmitter circuit	19
E. m. f.	4 volts
Current = $4 \div 19.9 =$2 ampere

Further comment is unnecessary. Nor is this all. In measuring a transmitter circuit with a Wheatstone bridge and galvanometer, we get, when at rest, say, 18 ohms, but talk into the transmitter and the resistance will rise to 30 or 40 ohms, due to the self-induction of the coil so that the amount of current will be only about half that given above, which makes the matter of internal resistance of still less importance.

¹Approximate.

In setting up sal-ammoniac cells many people use too much sal-ammoniac. Use only a trifle more than the water will dissolve and a longer life and just as much current will be obtained.

CENTRAL BATTERY SYSTEMS.

As central battery systems are attracting considerable atten-

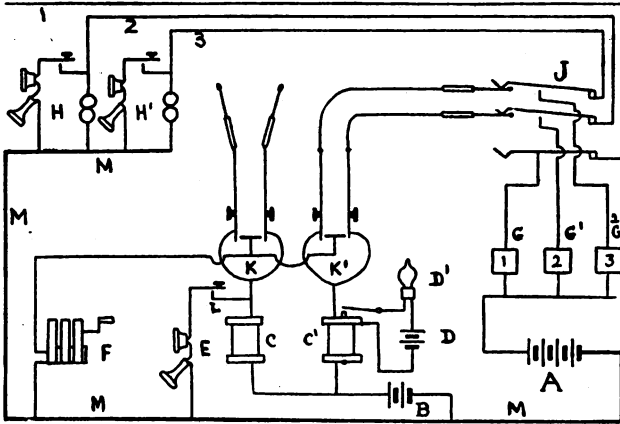

FIG. 55.

(A) Storage battery for calling; can be charged with primary batteries, outside current or with motor generator, the latter device can be used direct if preferred.

(B) Talking battery; storage or primary cells can be used.

(C, C') Choke coils.

(D) Local battery for ring-off signal.

(D¹) Small incandescent lamp or annunciator for ring-off signal.

(E) Operator's telephone.

(F) Magneto generator for ringing subscribers' bells.

(G, G', G'') Switchboard drops.

(H, H') Subscribers' telephones on lines 2 and 3.

(J) Line jacks.

(K, K') Cord pairs and ringing keys.

(L) Operator's listening key—one for each pair of cords.

The lamp D¹ remains burning while subscribers are talking. If either of the subscribers connected wishes to call the operator's attention, he moves the switch hook several times, flashing the lamp D¹. When the telephones are hung up the lamp goes out.

(M) is the common return wire.

tion just now, such a system is shown in Fig. 55, which is being exploited by the Boardman-Tucker Company, of Boston, and with various modifications is a fair sample of all of them. A

subscriber desiring a connection removes the receiver from the hook, which cuts in the receiver and transmitter (connected in series, with no induction coil) in shunt with the magneto ringer. As the magneto ringer is wound to a high resistance (1,000 to 2,000 ohms), the battery flowing through it does not disturb the drop, but with the receiver off the hook the resistance of the subscriber's instrument becomes reduced to about 75 or 80 ohms. The operator inserts the plug in the jack, cutting off the line battery (A) and connecting with the transmitter battery (B). On party lines of from two to six stations central does all the ringing, and a subscriber calling does not disturb any other subscriber. Should a cross or ground occur, the drop will fall and stay down till the trouble is removed.

The cord connections differ from the ordinary. Each cord of a pair connects to one end of a choke or retarding coil through the coil to the talking battery, then to the common return wire or the other side of a metallic circuit. If two storage cells are used, as many as twelve pairs of cords can be put up at the same time without any cross talk, the choke coil between each pair acting as a current regulator; for, while it lets the direct battery through to energize the transmitters, it impedes the intermittent voice currents, and prevents them from backing into another pair of cords.

The shunting arrangement allows the current to pass through the telephones in proportion to the distance apart of the stations, and gives the maximum power to each transmitter. For systems of this kind lines of low resistance are necessary—in fact, they should not exceed 100 ohms; so that lines more than one mile in length should be of copper, and it would be better to have them entirely of copper; and, if it were possible, by means of artificial resistance, or otherwise, to balance up the lines so that the resistance of all were equal, still better results would be secured. The subscriber's ringing battery (A) may consist of storage cells, or gravity batteries, or even a constant current generator about the size of a fan motor. The choking coil in the cords is also a magnet, which attracts an armature. lighting the

lamp D' while the subscriber is talking, which is released and puts out the lamp when the receiver is hung up.

In some systems there is a choking coil in the subscriber's instrument, and a relay which lights a small lamp, which takes the place of the drop; or the drop itself may be used to light a signal lamp in the same manner as a night bell is rung.

Sometimes two or more lamps are used, one for the subscriber calling in, another when the cords are up, and still another for the ring-off, when one or the other subscriber hangs up.

The talking battery should be one of low internal resistance and constant current, such as a storage battery, the Edison-Lalande, or very large gravity cells. Supposing that two cells of storage battery are necessary to one section of the board, it would require about three cells of Edison-Lalande, three cells of Fuller, or five cells of gravity battery to do the same amount of work. Where long lines with induction coils are connected in, a few pairs of cords can be double wound, so that the choking coil becomes an induction coil.

The advantages of this system are low cost of instruments, absence of batteries at the subscriber's instrument, and all batteries at the central office, where they can be constantly inspected, while a few batteries may take the place of several hundred, and reduce the cost of inspection by at least one-half. Its only disadvantage in a small exchange is the cost of wire, as copper wire becomes almost a necessity unless for short lines.

REPEATING COILS.

Repeating coils are used to connect the exchange lines with long toll lines, for it is easy to see that a toll line connected with an exchange line direct, would be badly overbalanced unless both were metallic circuits. This coil is simply a modified and enlarged form of the induction coil, the resistance of both windings being generally the same. Its object is to keep the grounded and metallic circuit systems apart, to prevent the disturbances common to both from influencing each other.

The line is connected to one coil, either primary or secondary—it really does not matter if both coils are the same—while

the toll line is connected to the other side, as shown diagrammatically in Fig. 60. Figs. 56, 57 and 58 show the forms in most common use.

Fig. 56 is simply two spools with a common core of soft iron wires bunched together. Where there are a large number of toll lines on one board, this form is not very desirable, as it has considerable external magnetism and hence is liable to cross talk.

Fig. 57 is much the same, except that the spools are flat and placed close together.

Fig. 58 is just like an ordinary induction coil, except that the

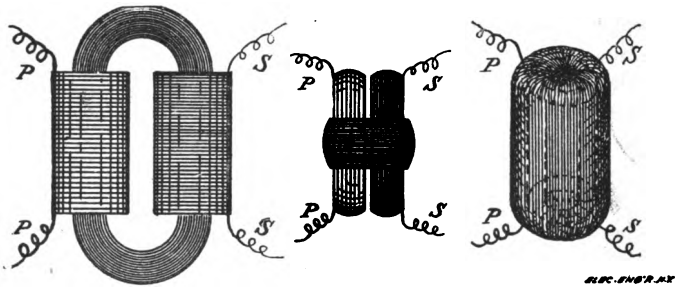

FIGS. 56, 57 AND 58.

wires of the core are left long enough to bend back and meet over the outside. This form should be the most efficient of any of the above, though each has its advocates.

Sometimes when coils are placed side by side, or end to end, considerable cross talk will pass from one to the other and, of course, this is undesirable. Fig. 59 shows how to avoid this, by so placing the coils that one is interposed as a barrier against the others, so that the external magnetic lines are broken up.

Fig. 61 shows the coils connected to line.

CROSS-CONNECTING BOARDS.

The cross-connecting board is one for connecting the switch-board cables to those outside. An ideal system for connecting wires would be for each outside cable number to be connected to the same subscriber's number as the drop, but for many rea-

sons this plan cannot be kept up. Subscribers will change their location and the wires belonging to them be given to some one else. New subscribers toward the end of a lead will be connected onto the end of shorter lines, in order to keep the wires on the pole line straight. Cable conductors will prove defective

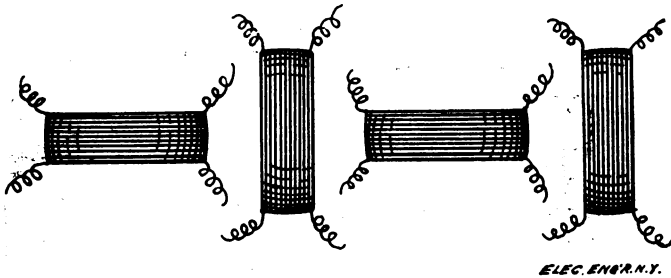

FIG. 59.

and others will have to be substituted, and in the long run such a system would be more troublesome than a simple cross-connecting board, which can be kept in the office, where changes can be made at a few minutes' notice.

There is a disposition on the part of some manufacturers, and even some Bell companies, to make this board as small as possible, and keep the wires as much as possible out of sight. Now, this is not necessary or desirable, as this board is always placed in a **back room** anyway, and the wires should be placed so that

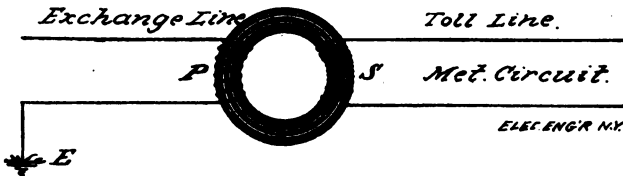

FIG. 60.

they can always be inspected and traced out; for when a change is to be made the inside man should not be put to any more trouble than is necessary in finding his wires.

I have seen boards so complicated that it took two men to make a cross-connection—one behind the board and one in front—which, of course, is very undesirable. Neither is it necessary to have the wires lie snug and pulled so tight that they cannot be moved, for the more free air surrounding a wire the higher the insulation, and the less the possible dampness and cross talk; and insulated wires thrown loosely together will give better serv-

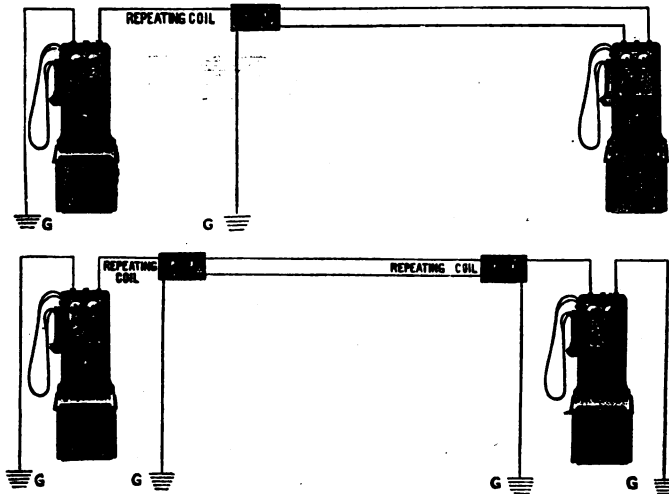

FIG. 61.

ice than if stretched to almost the breaking limit, and lashed tight.

In large exchanges the best and most simple plan is an open rack frame, to the front of which the cable terminals are fastened and to the back the switchboard cables, with the wires lying loosely on the rods which cross from one side to the other in much the same manner as they would on a series of ladders laid horizontally—in fact the whole frame presents very much this appearance.

The rack should be long enough to accommodate all the cable

terminals, together with their fuses and lightning arresters, but it need not be more than from one to two feet in width, and the cable strips should be far enough apart, say, six inches, so that a hand and arm can be inserted to change and remove the wires.

The cross-connecting board and cables should all be together, as it is a mistake to put the cables in one room, the switchboard in another, and the cross-connecting board in still another, as is sometimes done; this doubles the amount of office wiring and increases the cross talk to an astonishing degree. Place the cable terminals and cross-connecting board right behind the switchboard, where they belong, or, if this is impracticable, place them both in the same room at least.

For exchanges of not more than 500 subscribers the best form is a simple wooden case set against the wall, against which the outside terminals are brought and secured.

The terminals are connected to the lightning arresters in the same manner as those shown in Fig. 39 in the cable box. Placed alongside of these strips, with a space of about six inches separating them, are the switchboard strips to which the cross-connecting wires can be run. The space occupied by a 500-drop metallic circuit board of this kind would be about 6 feet by $4\frac{1}{2}$ by 1 foot. Space is left above and below the terminals and lightning arresters, so that wires can be transferred from one cable to another around the top and bottom, without the trouble of testing to find them. Of course a record should be kept of all cable connections, but in the hurry of transferring wires this is sometimes neglected, and it is convenient to be able to trace them out.

CHAPTER XIX.

HINTS ON EXCHANGE MANAGEMENT.

THE most important details connected with telephone work relate to the central office itself, and one of the most important of these is in regard to the service rendered.

Telephone service, to inspire confidence must be prompt and reliable, and a manager with comparatively inefficient instruments and lines, who looks sharply after the service and keeps his trouble out, will be on a great deal better terms with his subscribers, than one who, having the very best instruments and lines that experience and money can procure, neglects this important condition. For the best instruments now made will occasionally go wrong. No matter how carefully lines are built, they will sometimes break or cross.

Let us cite an example: A and B are rival managers of two exchanges in the same town, and both have about the same number of subscribers; A has a good plant and instruments that are up to date, but he cannot be made to see the necessity of attending to service details. His operators do not always attend strictly to business, and he never seems to find it out. Lines may get in trouble and remain so for a week (this is no exaggeration), and even when the operator reports a line as working badly, he seems to think that he has other work of more importance to attend to, so that the operators have got discouraged and quit reporting trouble. His employés, too, have caught something of the same spirit and have got into the habit of "letting things go." B, on the other hand, looks sharply after his trouble and instructs his operators to report it promptly as soon as discovered. His tours of collection are tours of inspection as well, and his operators understand that if they do not answer calls promptly they are liable to have some one else filling their places. Whenever he is in the office he

will take pains to call their attention to calls that are not answered as they should be, not harshly, for he is one of the best fellows alive; but attending strictly to business himself and all his office employés understand that they are hired to do the same, not to gossip or read novels, and that patrons must get the service they pay for, and in disputes between operators and subscribers, which will occur in the best regulated exchanges, they know that he will stand by them unless they are altogether in the wrong.

No matter what work he has on hand, trouble must be taken care of as soon as reported, even though a whole gang of men is kept waiting.

Now all this seems severe, yet his general good nature and unflinching courtesy make him a favorite both with employés and subscribers, and in the course of a year he begins to cut into his opponent's subscription list and A is still wondering why people prefer B's service to his own, forgetting or not knowing that his own neglect created grumbling, induced lack of confidence, and made enemies of the very men who were helping him in his business.

When a subscriber finds that he cannot raise "Central," he feels exasperated and not without reason, as he is paying for a continuous service, and has learned to depend upon the telephone the same as he would upon an employé, with this difference, when an employé is sick or absent the fact is generally known, and arrangements made to fill his place; but with a telephone out of order the fact is not discovered, perhaps, till the busiest part of the day, and its place can only be filled by a messenger. Again in some offices where there are only from 50 to 200 subscribers, the operators are perhaps young and giddy girls, or still more young and careless boys, who cannot always understand—unless reminded of it—the necessity of answering a call the very instant that it comes in. Perhaps they want to get to a stopping place in the book they are reading, or finish an interesting gabble with some clerk or "lady friend," while the impatient subscriber has to wait 10 or 15

seconds, which seem like so many minutes, and perhaps has to ring another time or two, before he is answered. Soon he begins to talk among his acquaintances about the "one horse exchange" and "poor service," and some day he goes over to the opposition company and perhaps takes some of his friends along with him. You may think that certain men are too mean to have any friends, but nearly all mankind is more or less amenable to suggestion, and while the above remarks may have no present influence, yet the people to whom they are made will remember them the very first time they have trouble with their own instruments.

Now all operators are not like this, but business heads cannot be expected on young and inexperienced shoulders, and the best of them need watching occasionally. Do not let them forget that they are there to serve the public first of all and remind them that troubles discovered should be promptly reported, and give them to understand that they will be as promptly attended to.

The saying of a Western electric light manager is apropos, "Keep the lights going, if the engine goes in the scrap heap to-morrow," which, being applied to telephone service, means: A subscriber wants to be answered as soon as he calls, and he wants the exchange every time he calls.

But prompt service is not the only thing necessary in training operators.

The work of operating a busy switchboard is confining and often irritating. The very best systems yet devised have their faults, and some of the newer boards have many. Subscribers feeling out of humor show a disposition to find fault, perhaps because the party called for does not answer promptly, or the line is "busy." In large exchanges operators are not allowed to converse with subscribers during business hours and patrons showing a disposition to argue matters are either shut off or switched over to the chief operator, but in the smaller exchanges there is no chief operator; the manager is away from the office fully half the time, and the girl has to bear the brunt

of complaints and fault finding alone. In such a case of course the young lady must be schooled to control her temper under all ordinary circumstances.

In a circular issued by certain railroads to employés occurs this sentence:

"Employés should show to patrons the same tact and courtesy that a business man would use with his customers."

It would be well to post this up in every exchange.

Many operators have such pleasant voices and pleasant ways that it is really a pleasure to call up the exchange. What though an operator is "quick as lightning" and can put up plugs at an astonishing rate if her call of "Number!!" makes a timid subscriber start back in alarm, and who upon the least provocation replies in language blunt as well as vigorous? Such a one is not fitted for the telephone business and should try some other occupation. On the other hand, it is worth considerable to an exchange to have its plug manipulators spoken of as "such nice, pleasant girls," "so accommodating," etc. Remember that the public judges an exchange largely by its operators, for, after the instrument is once installed, they see and hear very little of anyone else except the collector. The general public does not know of the work that operators have to do, and to enlighten them it is a pretty good idea to invite them to call and see the exchange in operation, where a little courtesy on the part of manager and operators will prevent a great deal of fault finding and establish a personal acquaintance which will create a better mutual understanding all around. Operators will generally try to please, for approbation is a woman's leading characteristic and a hint or suggestion covering these points, will generally be sufficient, for every girl likes to be well thought of.

But there is another quality in a girl's disposition which is not so easily controlled, viz., curiosity.

There is a general disposition on the part of young operators to cut in and listen to conversations, and even in some cases repeating what they hear. Now I know that as long as human

nature remains as it is, that it is hard to break up this habit unless she is fully occupied otherwise; but there are several reasons why this is wrong.

Every message between patrons should be regarded, by operators and officials, as confidential, never to be divulged under any circumstances, unless perfectly sure the parties would not object. If, however, the operator stays off the line, she will not hear anything she should not. Again, the girl should be instructed that every time she cuts in she throws either the resistance and self-induction of her own instrument into the line or throws in a "ground" reducing its efficiency in either case by that much. Suppose that two subscribers, owing to long lines, poor instruments, or a noisy location, can make themselves understood with difficulty, the operator by cutting in will increase the difficulty almost two-fold.

To be sure some patrons will not ring off when through talking, and the operator has to cut in to find out if they are through, but even then it is not necessary to cut in directly, as by putting one hand on the base of the plug and the other on one of the binding posts of the receiver she can shunt enough of the current to hear perfectly everything that is said, and even answer them if necessary. I know of one exchange where the operators use this plan almost altogether for cutting in after the plugs are up, while the high and non-inductive resistance of the body prevents any appreciable loss of current.

Have the room well furnished and well lighted. It is also a good idea to have it located in a front room, so that the operator can occasionally relieve the monotony of watching drops by looking out of the window. One manager I know even goes so far as to set the switchboard right beside the window, so that the operator does not have to leave her seat in order to see all that is going on in the street.

Give the girls all the conveniences and comforts that you can. Do not compel them to acquire a lame arm turning a hard, stiff hand generator; if you can procure a steady, reliable

power in your neighborhood, such as a small gas, water or electric motor, or a factory shaft running continuously, to turn it for them. Make the place attractive and show them the little attentions which they so much appreciate and the strictest discipline will hardly be felt.

Appendix.

WIRE TABLES AND FORMULÆ.

TABLES of weights and resistances as applied to copper are fairly reliable and consistent, the only differences being in the percentage of purity, manufacturers taking it at 96, 97 and 98 per cent., respectively, which will insure results with slight variations. It must not be forgotten, however, that the resistance varies with the temperature. Iron wires are made in all grades of purity and mixtures, and ores from different mines give different results, so that no two tables as applied to iron wire are exactly alike, but the ones given below are nearly enough correct for general purposes, and no one expects scientific accuracy from iron wire. The only way to tell to a certainty the resistance of iron or steel wire is to measure it.

To facilitate calculations a unit called the mile ohm is sometimes used. This is the weight of one mile of wire having a resistance of one ohm; and to get the resistance of any other wire, divide the mile ohm by its weight per mile.

Example No. 1.—What would be the resistance of a steel wire weighing 250 lbs. per mile, the mile ohm being 6500? $6500 \div 250 = 26$ ohms per mile. Ans.

Example No. 2.—What would be the weight per mile in the above case necessary to a resistance of 15 ohms per mile? In this case we simply divide the mile ohm by the resistance to get the weight per mile, for, $\text{mile ohm} \div \text{weight per mile} = \text{resistance per mile}$; $\text{mile ohm} \div \text{resistance per mile} = \text{weight per mile}$. In the above case $6500 \div 15 = 500$ lbs. per mile. Ans.

The breaking weight of wires is more easily remembered by considering it as a certain number of times its mile weight. For example, if a wire weighing 250 lbs. to the mile, breaks at 750

lbs., its breaking factor is 3, and having found this for one wire the same factor will apply to all sizes of that particular manufacture or grade.

The following table gives the comparative values in a form easily remembered or easily copied into a note book:

	Lbs. per mile ohm.	Breaking weight = times weight per mile.	Breaking weight in lbs. per sq. in.	Specific gravity.	Comparative con- ductivity to copper 98 per cent. pure of equal size.	Percentage of w't to hard drawn cop- per.	Size of wire equal in conductivity to No. 10 E. & S. copper.
E. B. B.	4,700	3	53,100	7.73	.16	.864	No. 4 B. W. G.
B. B.	5,500	3.3	58,410	7.79	.14	.87	No. 3 B. W. G.
Special steel	6,500	6	100,000	7.85	.12	.877	No. 2 B. W. G.
Copper, soft	878	1.6	34,000	8.94	.98	...	5.4 ohms
Copper, hard drawn.	878	3	61,000	8.95	.98	...	per mile.
Bi-metallic ..	1,317	4.1	65,000	8.49	.66	.94	No. 8 B. & S. G.
Aluminum ..	440	9	45,000	2.68	.60	.30	No. 8 B. & S. G.

To find the weight of a cubic foot of any article multiply its specific gravity by 62.4 lbs., which is the weight of a cubic foot of water at 32 degs. F., or by .0361 lbs., the weight of a cubic inch of water, if the weight of a cubic inch is desired.

SPECIFIC INDUCTIVE CAPACITIES.

Dry air1	India rubber (vulcanized).....	2.94
Ozite	1.80 to 2.16	Shellac	2.95
Paraffine wax	1.92 to 2.47	Gutta percha	4.2
Resin	2.55	Mica	5.0
India rubber (pure).....	2.34	Glass6 to 10.

PROPERTIES OF COPPER WIRE—BROWN & SHARP GAUGE.

Number.	Diam. mils.	Areas in cir. mils. C. m. = d ² .	Weight in pounds per 1000 ft.	Weight in pounds per mile.	Res. per 1,000 ft. 98 per cent. 75° F.	Res. per mile 98 per cent. 75° F.	Breaking Weights.	Hard Drawn.	Soft.
0.	325	105,625	320	1688	.0994	.525	4558	2818	
1.	289	83,521	253	1335	.1258	.664	3746	2234	
2.	528	66,564	202	1064	.1579	.8336	3127	1772	
3.	229	52,441	159	838	.2004	1.058	2480	1405	
4.	204	41,616	126	665	.2525	1.323	1967	1114	
5.	182	33,124	100	529	.3172	1.675	1559	883	
6.	162	26,244	79	419	.4004	2.114	1237	700	
7.	144	20,736	63	331	.5067	2.675	980	555	
8.	128	16,384	50	262	.6413	3.386	778	440	
9.	114	12,996	39	208	.8085	4.27	617	340	
10.	102	10,404	32	166	1.01	5.33	789	277	
11.	91	8,281	25	132	1.269	6.7	388	219	
12.	81	6,561	20	105	1.6	8.5	307	174	
13.	72	5,184	15.7	83	2.027	10.7	244	138	
14.	64	4,096	12.4	65	2.565	13.54	193	109	
15.	57	3,249	9.8	52	3.234	17.07	153	87	
16.	51	2,601	7.9	42	4.04	21.33	133	69	
17.	45	2,025	6.1	32	5.189	27.4	97	55	
18.	40	1,600	4.8	25.6	6.567	34.67	77	43	
19.	36	1,296	3.9	20.7	8.108	42.8	61	34	
20.	32	1,024	3.1	16.4	10.26	54.2	48	27	
22.	25.3	640.1	1.9	10.2	16.4				
24.	20.1	404	1.2	6.5	26				
26.	15.9	252.8	.77	4	41.56				
28.	12.6	158.8	.48	2.5	66.18				
30.	10	100	.3	1.6	105				
32.	8	64	.19	1.02	164.2				
34.	6.3	39.7	.12	.63	264.7				
36.	5	25	.076	.4	420.3				
40.	3.145	9.8	.0299	.157	1075				

FOOT NOTE.—The tables given for copper, bi-metallic and iron wires are made up from data published by John A. Roebing's Sons Co., Trenton, N. J.

In drawing specifications regarding the resistance of wires, it must not be forgotten that temperature is an important factor. Thus a copper conductor having a resistance of 100 ohms at 32 degs. F., would have its resistance increased to 113 ohms when the thermometer reaches 90 degs. F.

BI-METALLIC WIRE.

Size B. & S. Gauge.	Diameter Decimal parts of Inch.	Weight per mile. Pounds.	Strength. Pounds.	Resistance per mile. Ohms.
00.	.36480	2,022	7,000	0.65
0.	.32486	1,620	5,700	0.81
1.	.28930	1,264	4,600	1.04
2.	.25763	1,003	3,800	1.31
3.	.22942	797	3,200	1.65
4.	.20431	629	2,600	2.09
5.	.18154	490	1,790	2.69
6.	.16202	398	1,500	3.31
7.	.14428	314	1,210	4.20
8.	.12849	246	1,020	5.31
9.	.11443	203	850	6.45
10.	.10189	157	660	8.10
11.	.09074	127	520	10.35
12.	.08081	100	410	13.0
13.	.07196	78	315	16.35
14.	.06408	63	260	20.55
15.	.05706	50	205	22.0
16.	.05082	40	160	33.75
17.	.04525	30	127	39.82
18.	.04030	25	100	50.39

Note.—The percentage of copper and steel may vary a trifle, hence the strength and weight must be approximate.

The conductivity of this wire is given as 65 per cent. of pure copper, but as hard drawn copper is not quite pure, the conductivity was advanced to a trifle above 66 per cent., making its relative resistance to copper 1.5.

PROPERTIES OF GALVANIZED IRON AND STEEL WIRE.

Size B. W. G.	Diameter in mils.	Weight per mile, lbs.	Breaking weights, lbs.		Resistance per mile, ohms.		
			Iron.	Steel.	E.B.B.	B.B.	Steel.
0.	340	1607	4821	9079	2.93	3.42	4.05
1.	300	1251	3753	7068	3.76	4.4	5.2
2.	284	1121	3363	6335	4.19	4.9	5.8
3.	259	932	2796	5268	5.04	5.9	6.07
4.	238	787	2361	4449	5.97	7.0	8.26
5.	220	673	2019	3801	7.0	8.18	9.56
6.	203	573	1719	3237	8.21	9.6	11.35
7.	180	450	1350	2545	10.44	12.21	14.43
8.	165	378	1134	2138	12.42	14.53	17.18
9.	148	305	915	1720	15.44	18.06	21.35
10.	134	250	750	1410	18.83	22.04	26.04
11.	120	200	600	1131	23.48	27.48	32.47
12.	109	165	495	933	28.46	33.3	39.36
13.	95	125	375	709	37.47	43.85	51.82
14.	83	96	288	541	49.08	57.44	67.88
15.	72	72	216	407	65.23	76.33	90.21
16.	65	59	177	332	80.03	93.66	110.7
17.	58	47	141	264	100.5	120.4	139.0
18.	49	33	99	189	140.8	164.8	194.8

ALUMINUM WIRES.

Aluminum wire has a conductivity of from 60 to 66 per cent. that of pure soft copper.

The following tables are furnished by the Pittsburg Reduction Co., as applied to their product:

PROPERTIES OF ALUMINUM WIRE.

Size B. & S. Gauge.	Diameter cir. mils.	Weights per mile, pounds.	Resistance. per mile.	Breaking weight. Pounds.
1.	289	403	1.09	2809
2.	258	319.5	1.37	2346
3.	229	253	1.73	1860
4.	204	201	2.19	1476
5.	182	159	2.76	1170
6.	162	126	3.48	927
7.	144	100	4.39	735
8.	128.5	79.5	5.53	583
9.	114	63	6.97	462
10.	102	49	8.80	366
11.	91	40	11.1	291
12.	81	31.5	14	231
13.	72	25	17.6	183
14.	64	20	23	147

SUPPORTING CAPACITY OF GALVANIZED STRANDS.

The following table is taken from Roebbling's Hand Book, and is the supporting capacity of ordinary steel strands as applied to the suspension of cables. The following table applies to ordinary steel span wire. Special steel will carry 2.2 times as much. The dip or sag in the centre equals .01 of span, factor of safety of 2.

Diameter of strands in 32ds of an inch.	SPANS IN FEET.								
	100	110	120	125	130	140	150	175	200
	WEIGHTS OF 1,000 FT. OF CABLE IN LBS.								
16	2818	2516	2263	2152	2050	1867	1709	1391	1154
15	2520	2247	2020	1920	1827	1663	1520	1234	1130
14	2030	1812	1630	1550	1476	1344	1230	1001	900
12	1580	1409	1266	1204	1146	1043	953	774	640
10	1110	899	890	846	805	733	670	544	450
9	860	765	680	652	620	563	513	414	340
8	585	521	468	445	423	385	352	285	235
7	433	385	346	329	313	284	260	210	172
6	337	300	270	257	245	223	204	165	137

