

Galvanometer

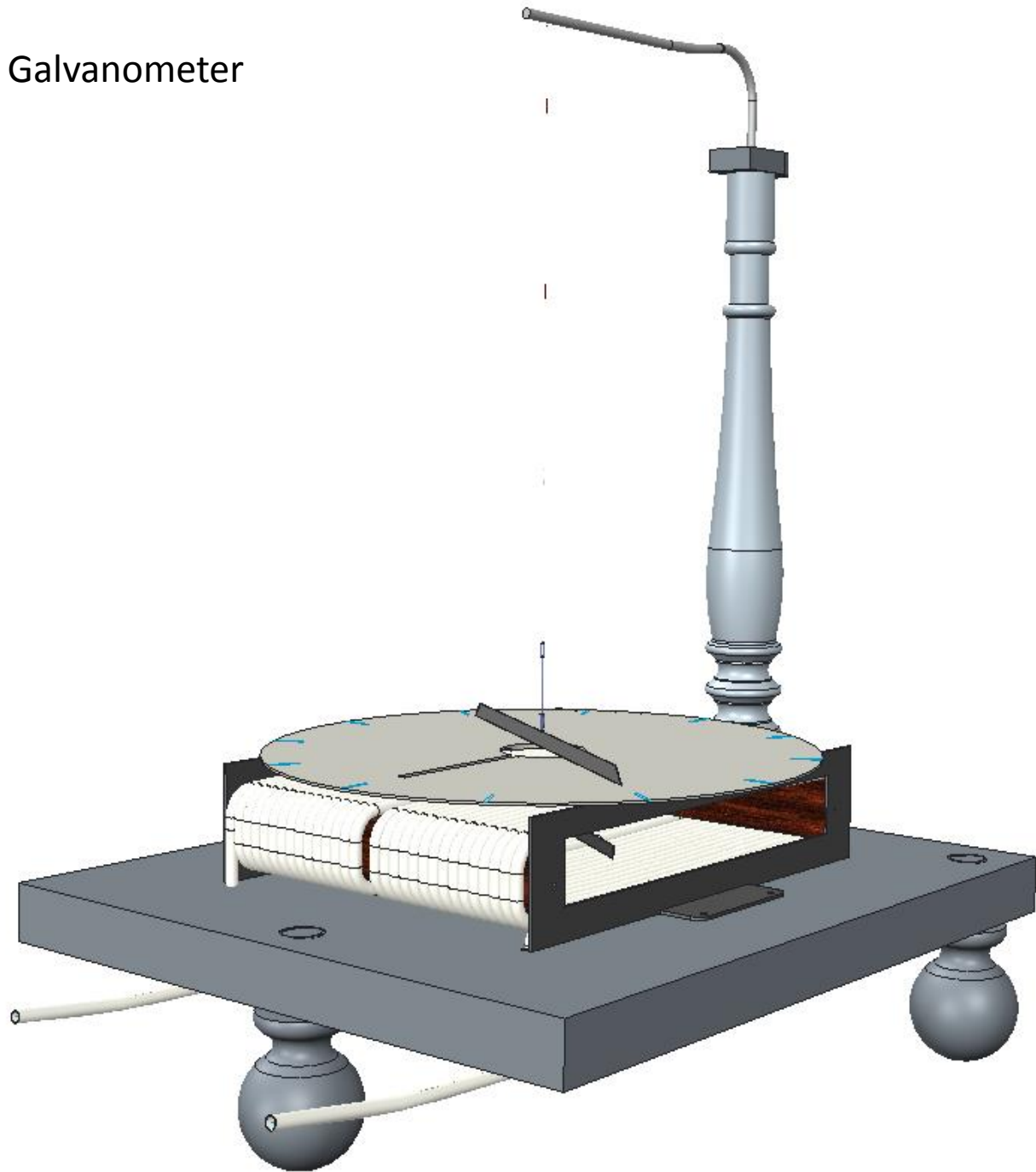

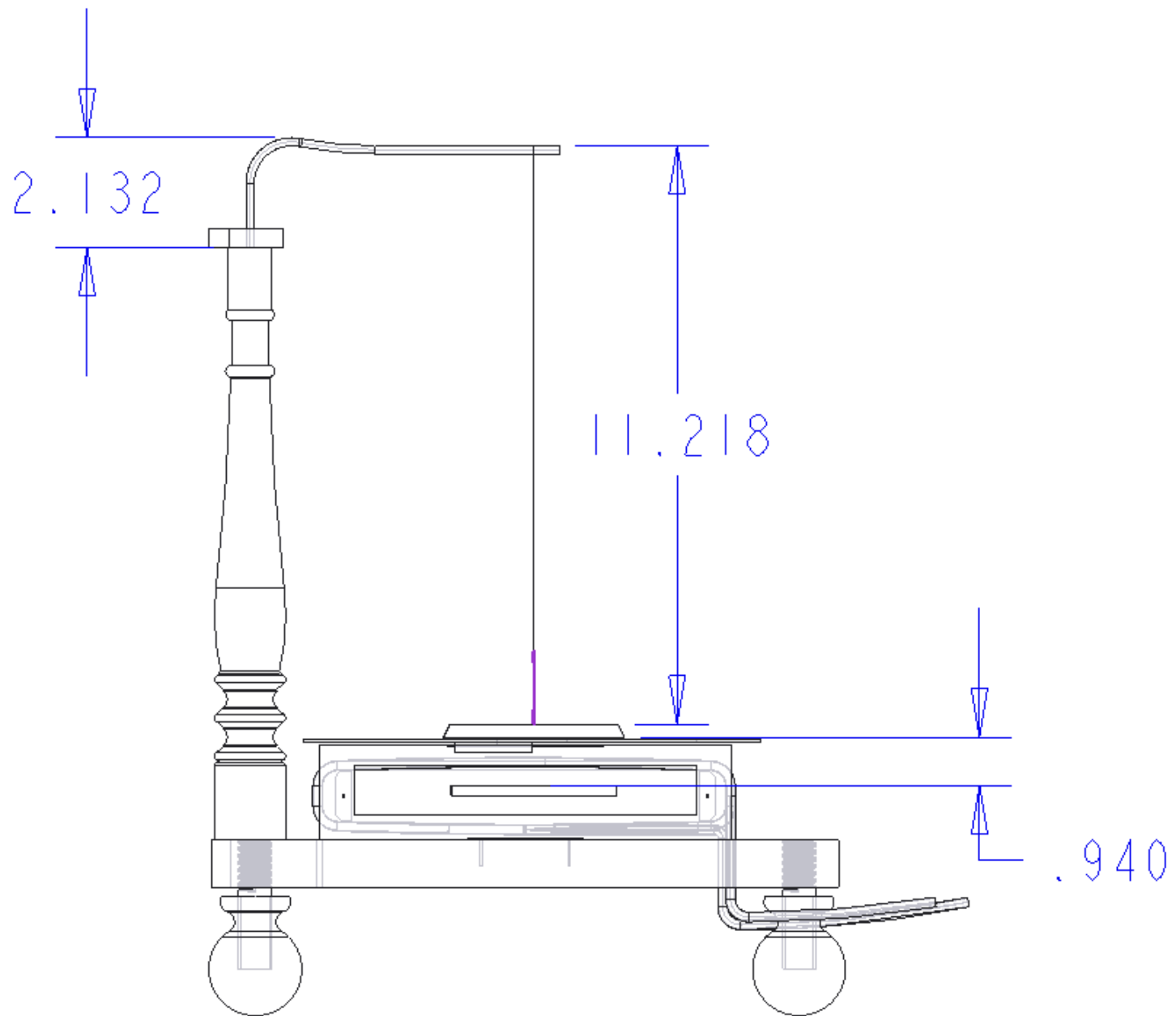

Base

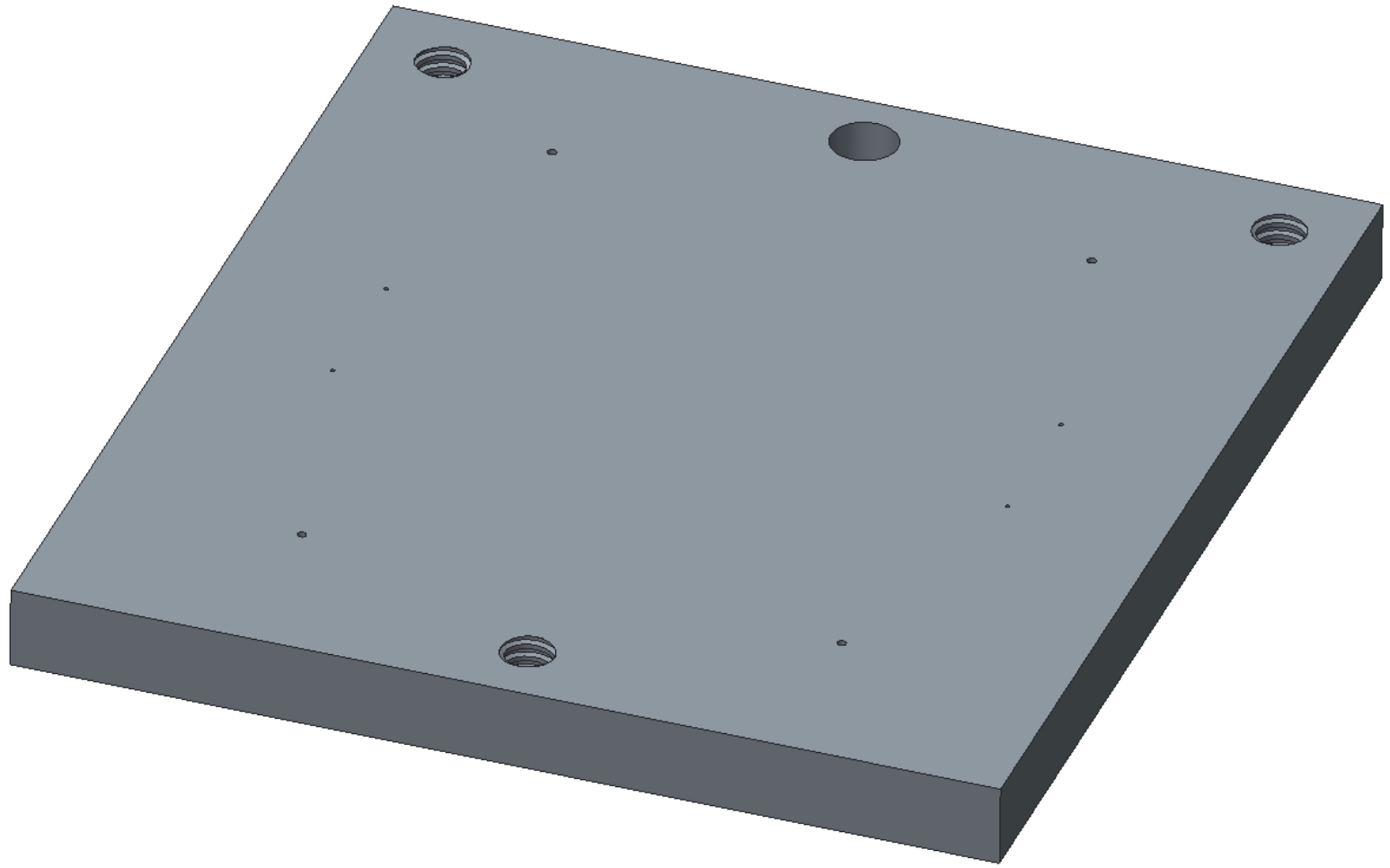

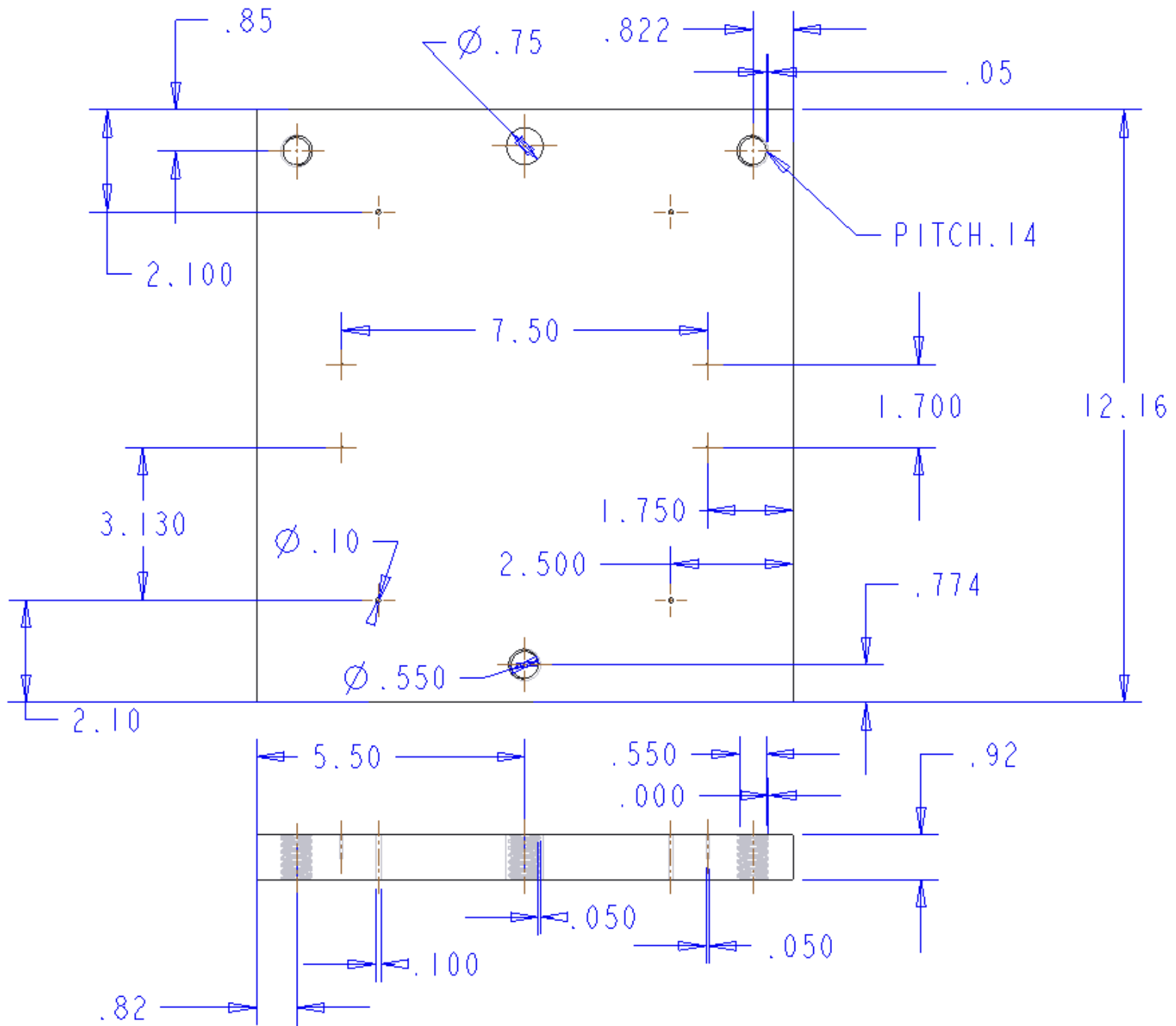

Legs (x3)



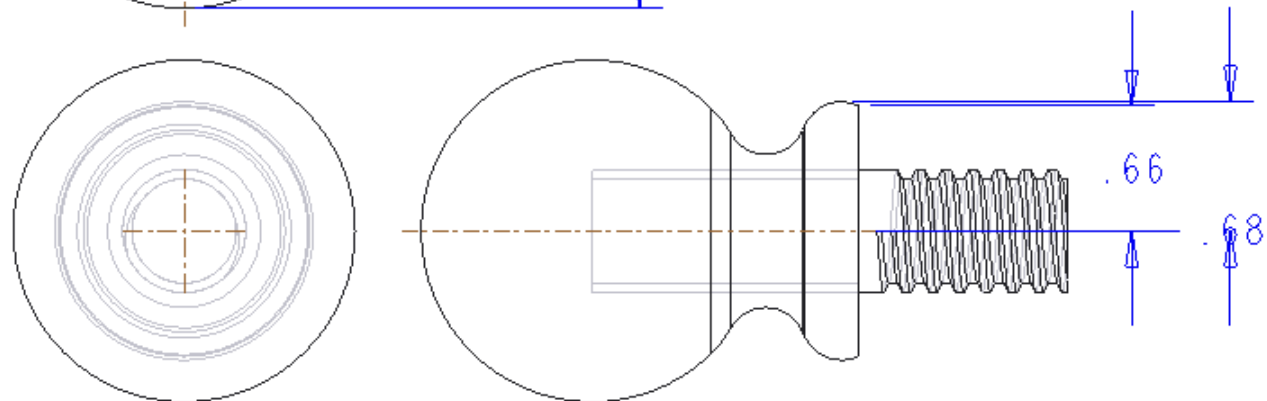
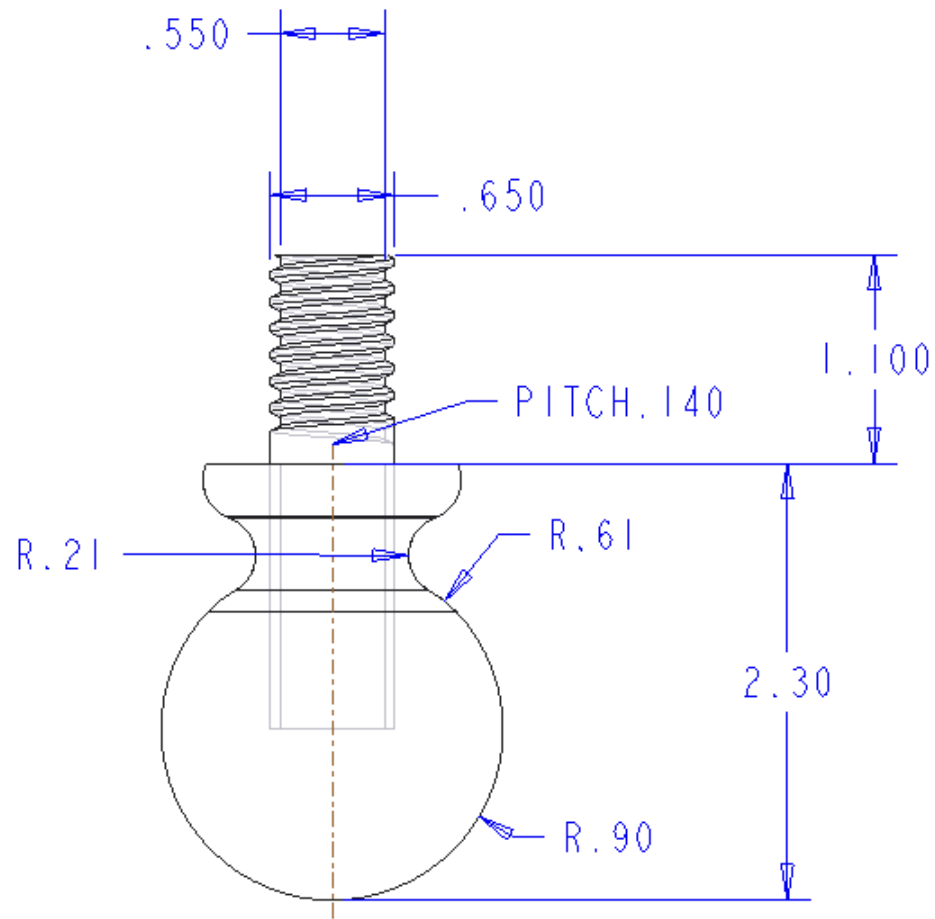

Metal Side (x2)



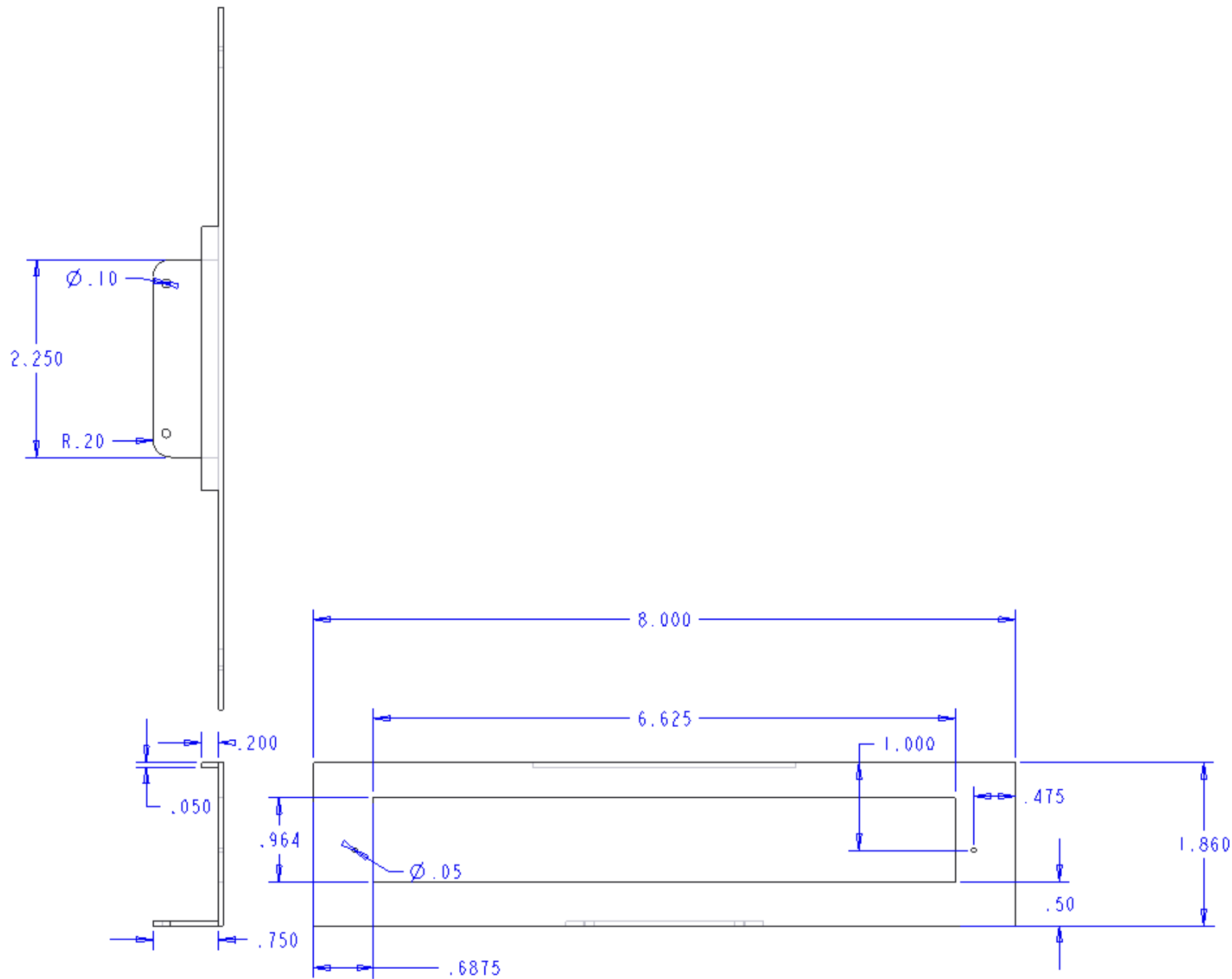



Wood Coil Block (x2)



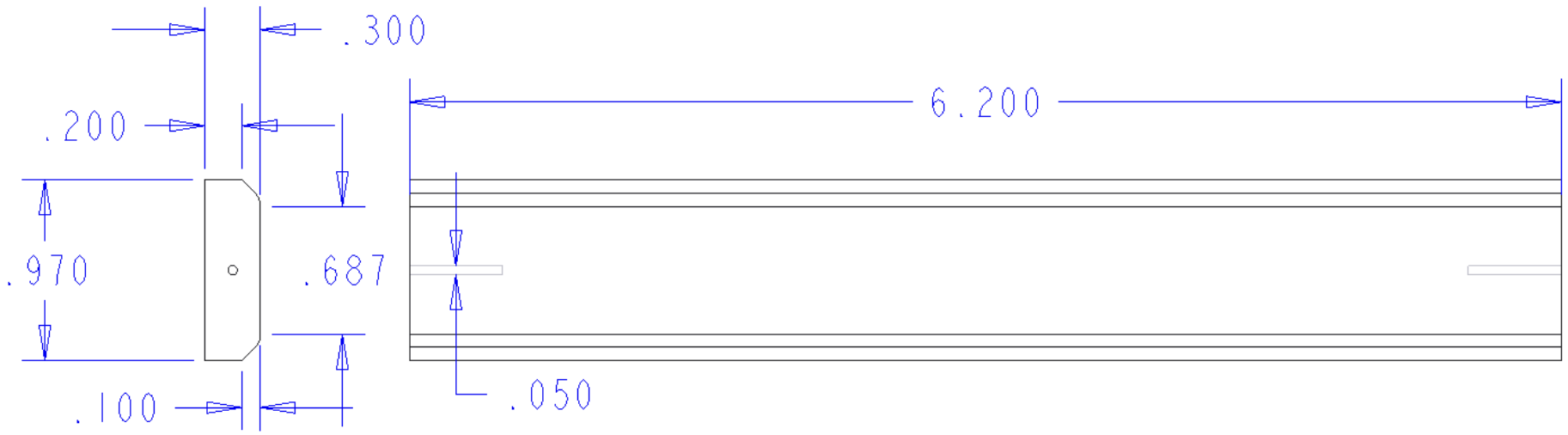

SCALE : 1.000 TYPE : PART NAME : WOODBLOCK SIZE : C

Top Needle

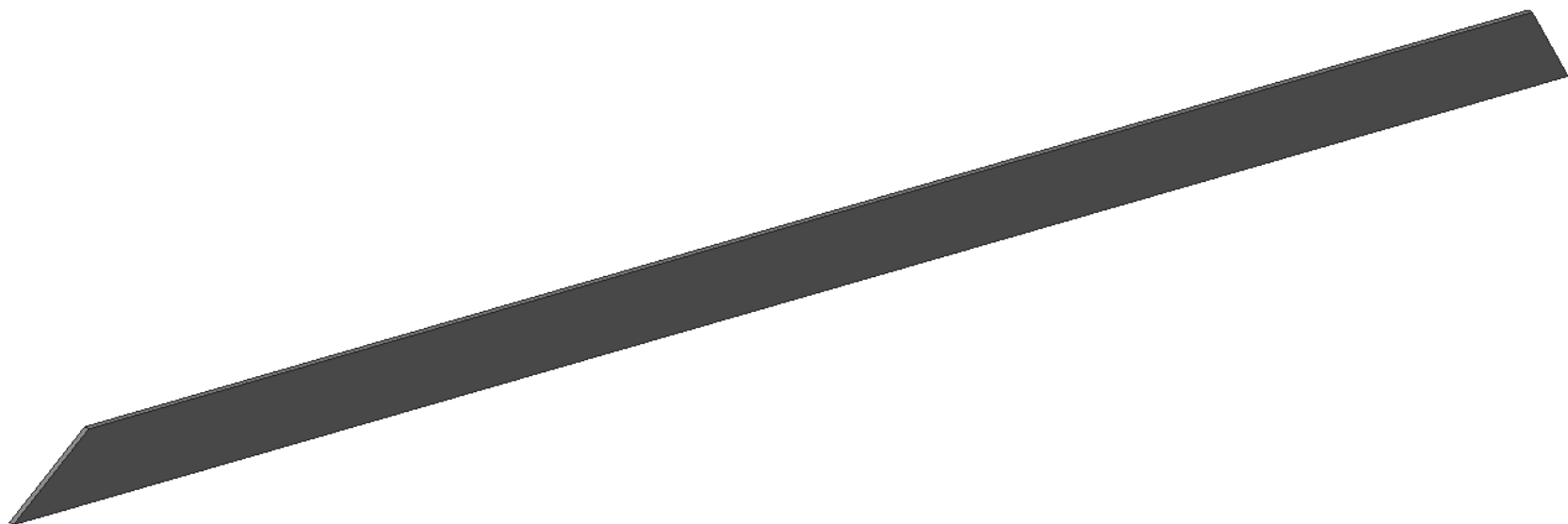

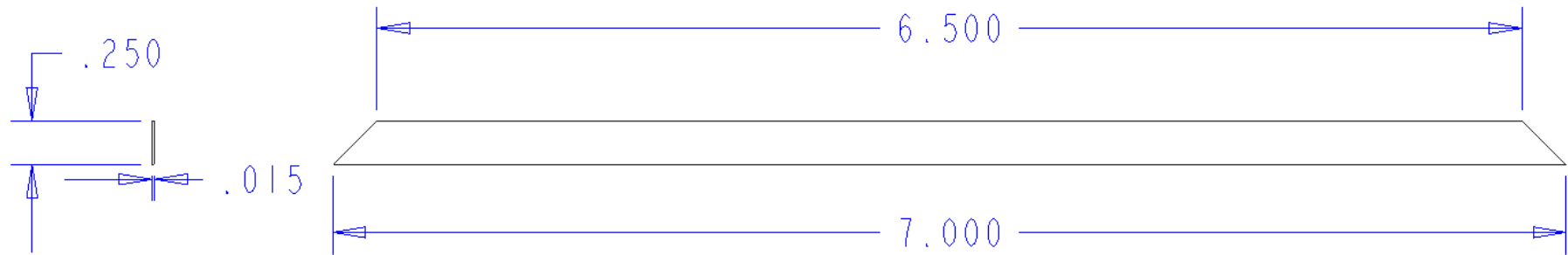

SCALE: 1.000 TYPE: PART NAME: LARGENEEDLE SIZE: C

Bottom Needle

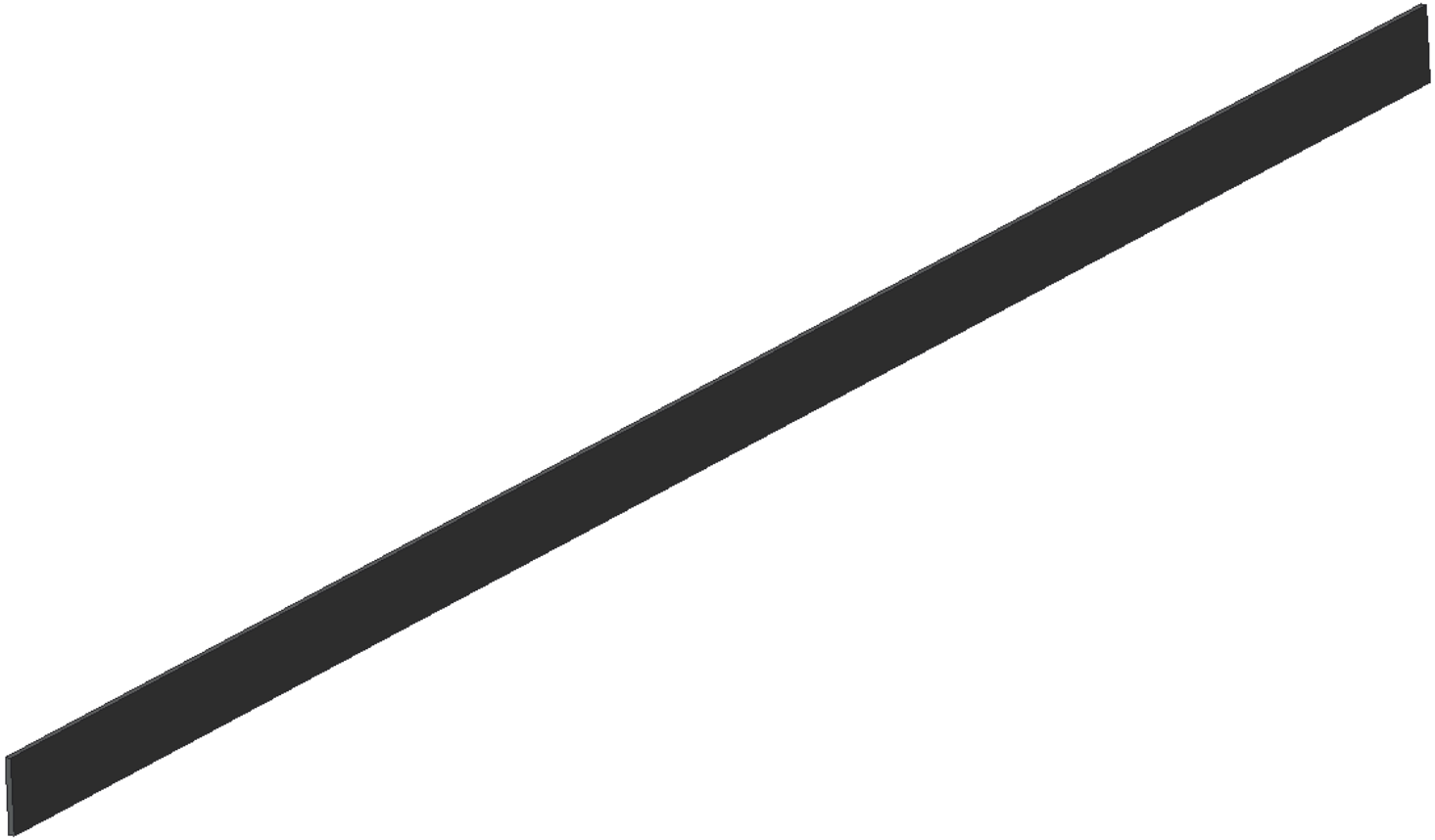

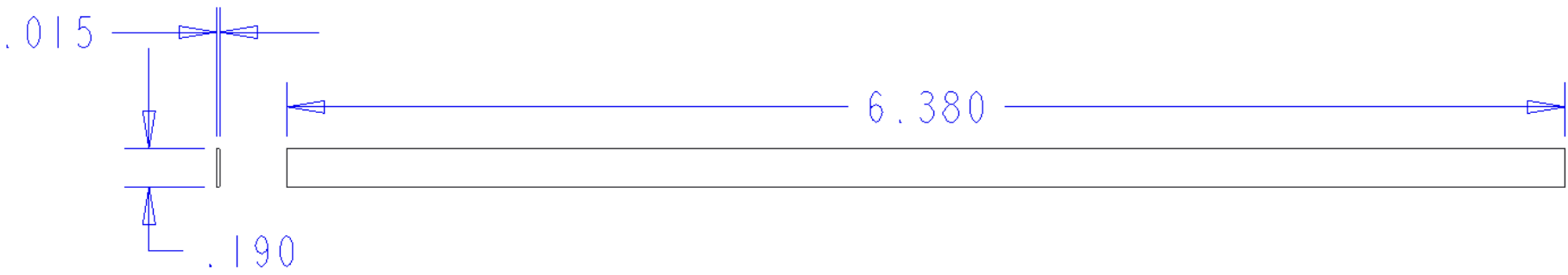

SCALE: 1.000 TYPE: PART NAME: BOTTOMNEEDLE SIZE: C SHEET 2 OF 2

Column

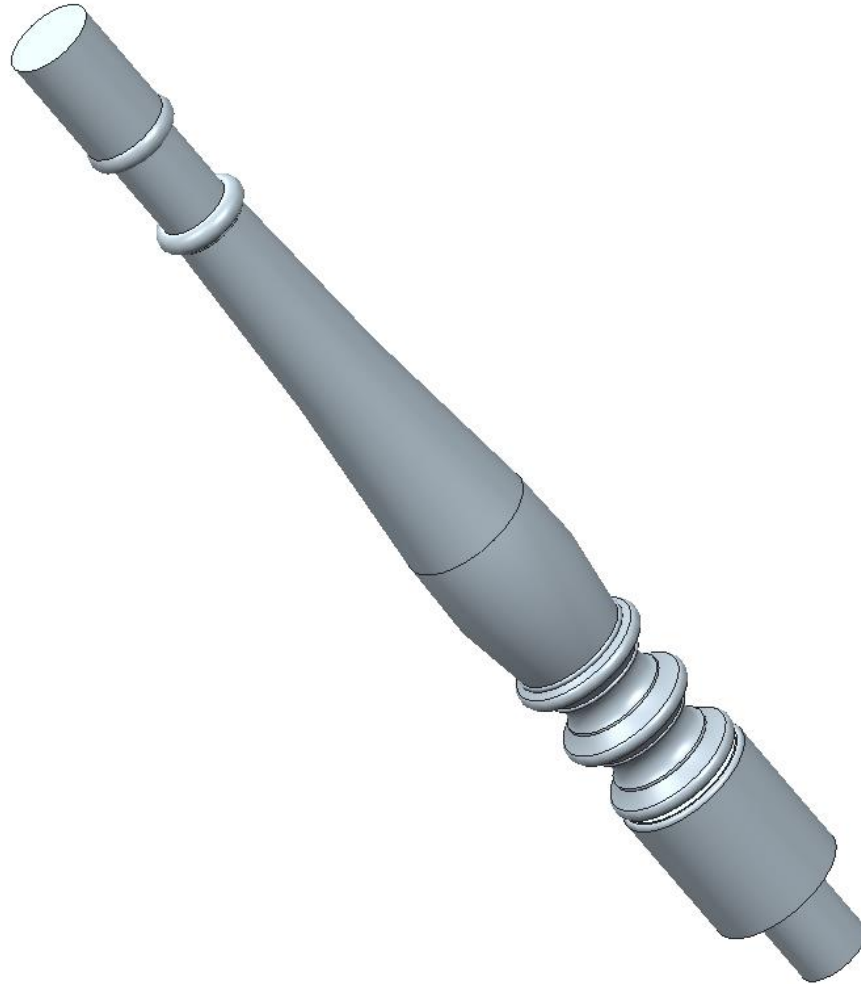

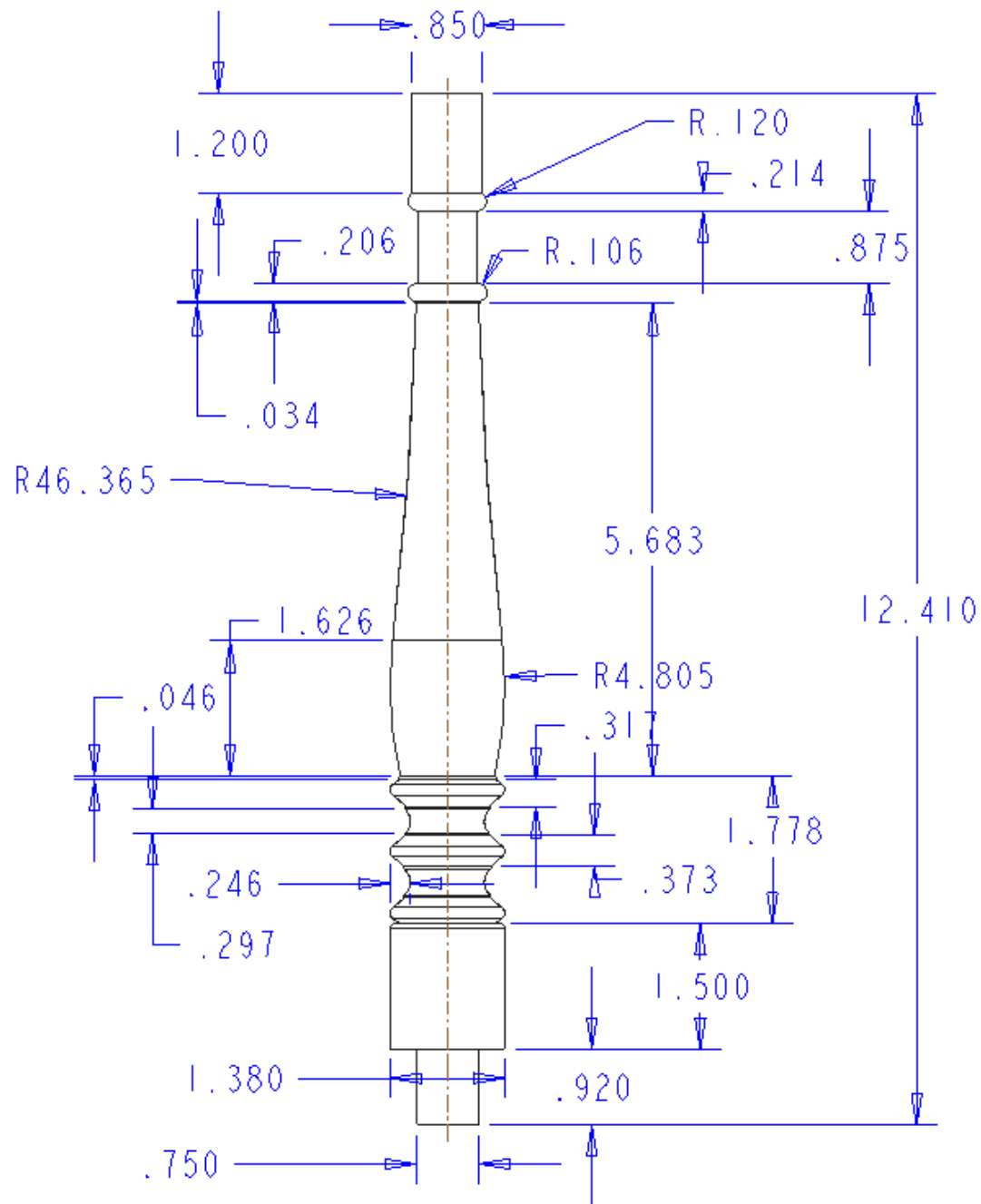



Column Top

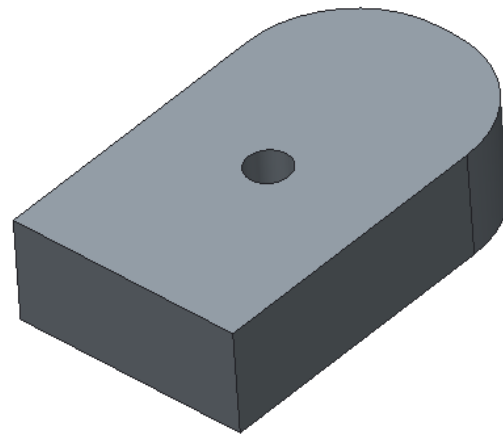

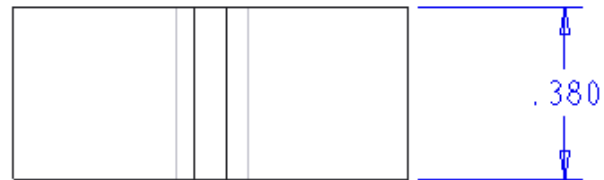
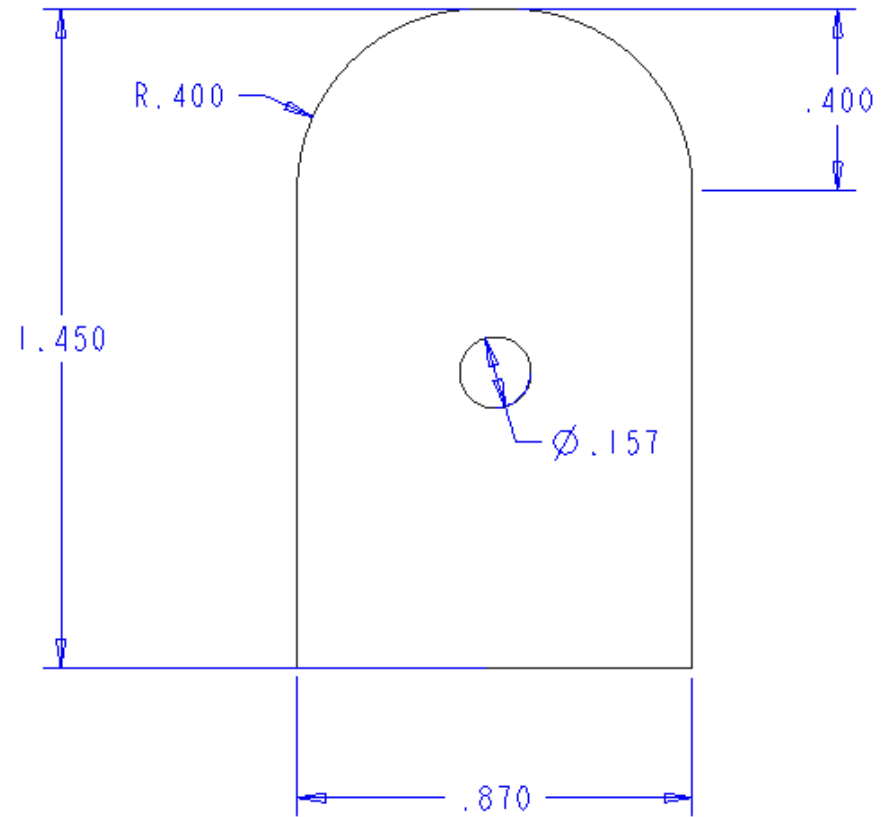

Coil

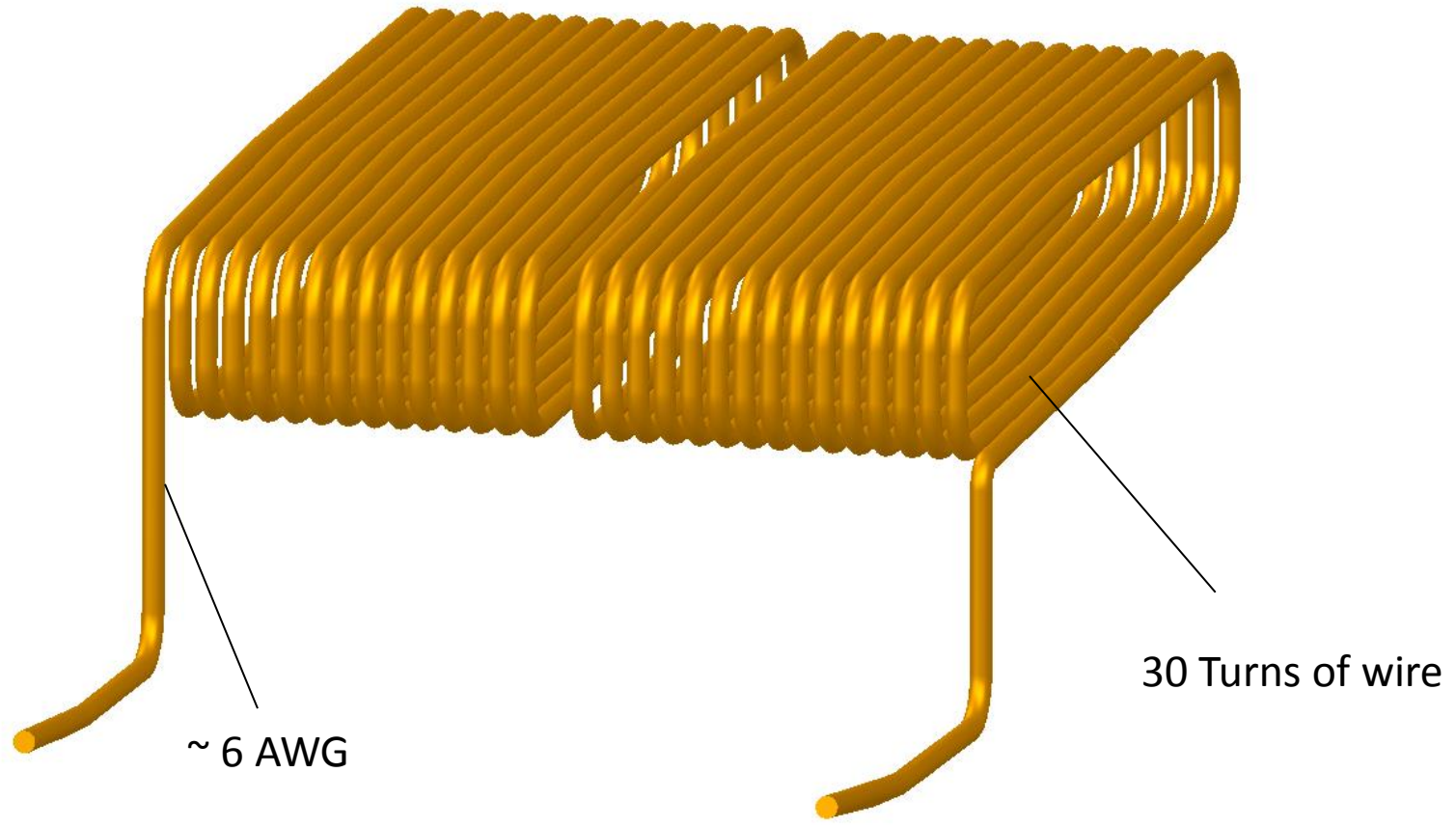

~ 6 AWG

30 Turns of wire

Dial

