

1959/1960

TRIUMPH
TIGER CUB

**REPLACEMENT
PARTS CATALOGUE**

No. 7

★

**TIGER CUB
'A' RANGE MODELS**

T20 T20S T20SL T20T

FROM ENGINE NO. 56350



REPLACEMENT PARTS CATALOGUE No. 7

TIGER CUB
"A" RANGE MODELS
T20
T20S
T20SL
T20T

from Engine No. 56360

September 1959

TRIUMPH ENGINEERING COMPANY LIMITED
MERIDEN WORKS · ALLESLEY · COVENTRY · ENGLAND
TELEPHONE MERIDEN 331 TELEGRAMS "TRUSTY, COVENTRY"

PUBLISHED MARCH 1961

TRIUMPH GUARANTEE

1. In this Guarantee the word "machine" refers to the motor cycle, scooter, motor cycle combination or sidecar as the case may be, purchased by the Purchaser.
2. In order to obtain the benefit of this Guarantee, the Purchaser must have correctly completed the registration form and returned it to us within fourteen days of the purchase.
3. We will supply, free of charge, a new part in exchange for, or, if we consider repair sufficient, will repair free of charge any part proved within six months of the date of purchase of any new machine, (three months overseas) or within three months of its renewal or repair in the case of a part already renewed or repaired, to be defective by reason of our faulty workmanship or materials. We do not undertake to bear the cost of fitting such new or repaired part or accessory.
4. Any part considered to be defective must be sent to our Works, carriage paid, accompanied by the following information:—
 - (a) Name of purchaser and his address;
 - (b) Date of purchase of machine;
 - (c) Name of dealer from whom the purchase was made;
 - (d) Engine number and model.
5. This Guarantee shall not extend to defects or damage appearing after misuse, neglect, abnormal stress or strain, or the incorporation or affixing of unsuitable attachments or parts and in particular:—
 - (a) Hiring out;
 - (b) Racing and Competitions;
 - (c) Adaptation or alteration of any part or parts after leaving our Works;
 - (d) The attaching of a sidecar in a manner not approved by us or to an unsuitable motor cycle.

This Guarantee shall not extend to machines whose trade mark, name or manufacturing number has been altered or removed, or in which has been used any part not supplied or approved by us, or to tyres, saddles, chains, speedometers, revolution counters and electrical equipment or to parts supplied to the order of the Purchaser and different from our standard specification.
6. Our liability and that of our dealer who sells the machine, shall be limited to that set out in this guarantee, and no other claims including claims for consequential damage or injury to person or property, shall be admissible. All other conditions and warranties statutory or otherwise and whether express or implied are hereby excluded and no guarantee other than that expressly herein contained applies to the machine to which this Guarantee relates or any accessory or part thereof.
7. We reserve the right to modify or deviate from the Published Specification without notice.

REPAIRS GUARANTEE

1. Whilst the highest standard of workmanship and materials is aimed at, we cannot accept liability for any defects appearing more than three months after the machine, assembly or component has left our Works after being repaired.
2. We will repair or replace at our option free of charge any defective work, materials or parts relating to the repairs carried out by us appearing within that time but shall not be under any further or other liability for any other loss or damage whether direct or consequential and our liability shall be limited to the cost of so making good. We do not undertake to bear the cost of fitting any replacement or repaired part.
3. We do not accept liability in respect of parts of proprietary manufacture, e.g. tyres, saddles, chains, speedometers, revolution counters and electrical equipment which may be used by us in effecting a repair. All other conditions and warranties statutory or otherwise express or implied are hereby excluded.

TRIUMPH SPARES

HOW TO ORDER. Every part is indicated by number, and this should be quoted together with the description. In order to assist customers, dimensions have been given in many cases where parts are similar. Parts where possible have been listed in order of assembly and a number of the illustrations show the assembly order also. With these aids there should be no difficulty in identifying the parts you require. **Always head your order with the engine number, stamped on the left side of the crank case underneath the cylinder flange, together with the prefix letters.**

WHERE TO OBTAIN. Triumph Spare Parts can only be obtained from an authorised Triumph Dealer, and we recommend our customers to place their orders with the Triumph Dealer in their district. When parts not usually asked for are required, and for which the Dealer may have to write or obtain specially, the postage or carriage incurred becomes payable.

Triumph Spares are not supplied to private owners direct from the factory. A list of authorised dealers who stock Triumph spares is published overleaf. If difficulty is experienced in obtaining the required parts, the matter should be taken up directly with the Triumph Spares Department.

Customers are warned against the risk incurred by purchasing parts that are not of genuine Triumph manufacture. This risk is eliminated if parts are ordered as instructed from recognised Dealers.

PATTERNS AND PARTS FOR REPAIR. It is not necessary to send patterns if the part number is quoted. The sending of patterns often delays the order as parcel post or rail takes longer than letter post.

Parts sent to Coventry for repair, replacement, or as patterns should bear the sender's name and address and clear instructions should accompany the parts. In your own interest send a copy of the advice note under separate cover. All parts must be forwarded carriage paid and care should be taken to ensure that all remittances are sent separately and not enclosed with the parts. Fragile units such as cylinders, etc., should always be boxed to avoid damage in transit. Complete machines should have all fitments such as windscreens, driving mirrors, tools, etc., removed by the sender before despatch, as it is impossible for us to accept responsibility in the event of loss in transit. We are always pleased to give estimates for overhauling and repairs, but should an estimate not be accepted, a charge will be made covering cost of dismantling and re-assembling, if carried out.

Communications relating to Parts should be addressed to the SPARES DEPARTMENT and for repairs, guarantee claims and technical advice to the SERVICE DEPARTMENT, Triumph Engineering Co. Ltd., Meriden Works, Allesley, Coventry. In order to facilitate quick reference, the quoting of any number, invoice number or reference from previous communications is essential. Accessories not of our manufacture should be sent direct to the actual makers, whose names and addresses appear below.

PROPRIETARY GROUP

Ancillary equipment which is fitted to our motor cycles is of the highest quality and is guaranteed by the manufacturers and not by ourselves. Any repairs or claims should be made to the actual makers or their local agents who will always give owners every possible assistance. The following are the addresses of the various manufacturers:—

CARBURETTERS.

Messrs. Amal Ltd.,
Holdford Road, Witton, Birmingham, 6.

CHAINS.

Renold Chains Ltd.,
Wythenshawe, Manchester.

ELECTRICAL EQUIPMENT.

Messrs. J. Lucas Ltd.,
Gt. Hampton Street, Birmingham, 18.

TYRES.

Dunlop Rubber Co. Ltd.,
Fort Dunlop,
Birmingham, 24.

SPARKING PLUGS.

Champion Sparking Plug Co. Ltd.,
Feltham, Middlesex.

K.L.G. Sparking Plugs Ltd.,
Cricklewood Works, London, N.W.2.

Lodge Plugs Ltd.,
Rugby, Warwickshire.

SPEEDOMETERS.

Messrs. Smiths Motor Accessories Ltd.,
Cricklewood Works, London, N.W.2.

SUSPENSION UNITS.

Messrs. Girling Ltd.,
Kings Road, Tyseley, Birmingham, 11.

MAIN SPARES STOCKISTS

BEDFORDSHIRE

Dunstable B. G. England (Dunstable) Ltd., Half Moon Hill, London Road

Luton Kings Motors (Oxford) Ltd., 87, Park Street

BERKSHIRE

Reading Phillips & Bloomfield Ltd., 10-24, South Street

BUCKINGHAMSHIRE

High Wycombe ... A. W. Harrison & Son Ltd., Whitehill Garage, London Road

Slough Sid Moram Ltd., Wexham Road Corner, High Street

CAMBRIDGESHIRE

Cambridge Hallens of Cambridge Ltd., Union Lane

CHESHIRE

Alvanley (via Warrington) ... Mr. H. Dugdale, Greenbank Garage

Birkenhead Mr. Bob Simister, 540, 542, 544, New Chester Road

Chester Marsons (Chester) Ltd., 31-33 & 14, Bridge Street

Congleton Mr. J. Richardson, 56, Mill Street

Crewe Cookes Garages (Crewe) Ltd., 10/20 and 24/30, Nantwich Road

Hazel Grove, Stockport ... Warburton Bros. (Motor Cycles) Ltd., 260, London Road

Northwich Northwich Motorcycles Ltd., 133, Witton Street

Stockport Webbs Service Depot (Great Moor), 261, Buxton Road, Great Moor

CORNWALL

Launceston J. Wooldridge & Son, Western Road

Truro W. H. Collins & Son, Kenwyn Mews

CUMBERLAND

Carlisle J. E. Clarkson, 1, Chapel Street

DERBYSHIRE

Chesterfield Walter Wragg Ltd., 95, Lordsmill St.

Cromford David Tye Ltd., Water Lane

Derby Blacknell Motors Ltd., 10B, Osmaston Road

Long Eaton Mr. H. E. Butler, 70-72, Tamworth Rd.

DEVONSHIRE

Exeter P. Pike & Co. Ltd., Alington Street

Newton Abbot ... J. E. Green (Garages) Ltd., 87, Queen Street

Plymouth P. Pike & Co. Ltd., Millbay Road

Torquay P. H. Sharam Ltd., 244-246, Union St.

DORSET

Blandford The Badger Garages

Parkstone, Poole ... Mr. Bob Foster, 472-476, Ashley Road Homestead Garages Ltd., 212, Ringwood Road

Weymouth Tilleys (Dorset) Ltd., 9, Frederick Place, St. Thomas Street

DURHAM

Bishop Auckland ... Robsons Motor Cycles Ltd., 223, Newgate Street

Darlington Duplex Cycle & Motor Cycle Co., 10-16 and 21, Grange Road

Sunderland T. Cowie Ltd., Millfield Duuns Garages (Sunderland) Ltd., Wheatshaf Corner

ESSEX

Chelmsford Hadlers Garage Ltd., New Street

Colchester G. B. R. Motors Ltd., 1 & 2, East Hill

Dagenham Reginald Smith (Motorcycles) Ltd., Imperial House, New Road

Hornchurch Mr. T. W. Kirby, 10, Roneo Corner

Ilford J. J. Double Motorcycles Ltd., 1-4, Mildmay Road, Cranbrook Road, Barkingside

Romford Brooklands Motorcycle Spares Ltd., 94-98, North Street

Southend-on-Sea ... Ticketts Ltd., 33-35, Queens Road

GLOUCESTERSHIRE

Cheltenham A. Williams & Co. (Cheltenham) Ltd., 19-21, Portland Street

Gloucester Harpers Garage Ltd., 23a, Worcester Street

Stroud H. & L. Motors Ltd., Cainscross

HAMPSHIRE

Aldershot Archers Ltd., 149, Victoria Road

Basingstoke H. J. Gifford Ltd., Giffords Corner

Bournemouth ... Jenkin & Purser Ltd., 3-5, Lansdowne Road

Christchurch ... Marsh & Fry Ltd., 36, Bargates

Gosport Everetts Ltd., 55a, Forton Road

Lymington Craze Bros. Ltd., 1, Gosport Street

Portsmouth Glnfield Lawrence Ltd., Gloucester Garage, 147-151, Fratton Road

... .. Jenkin & Purser Ltd., 277-283, Copnor Road

Southampton ... Alec Bennett Ltd., 152, Portswood Rd.

Winchester Lawton & Wilson (Winchester) Ltd., Eastgate Street

HEREFORDSHIRE

Hereford A. Kear & Co., 52, Commercial Street

HERTFORDSHIRE

Hatfield W. Waters & Sons Ltd., 32, Great North Road.

Hemel Hempstead... Moores (Hemel Hempstead) Ltd., London Road

Hitchin Jimmy Lane Motor Cycles, 67, Hermitage Road

St. Albans Humming Bird Motorcycles, 391, London Road

Watford Lewis, Ellis & Foster Ltd., 204, Rickmansworth Road

KENT

Bromley	Boyer of Bromley, 38, London Road
Canterbury	Halletts of Canterbury Ltd., St. Dunstons Street
Chatham	Frank Bannister & Son Ltd., 26, Railway Street
Dartford	Schwieso Bros. Ltd., 177, Lowfield Rd.
Folkestone	Mr. J. A. Hitchcock, 91a, 93, Guildhall Street
Maidstone	Redhill Motors (Maidstone) Ltd., The Broadway
Ramsgate	Philpotts Garage Ltd., Canterbury Rd.
Sidcup	Arrow Motor Works (Kent) Ltd., High Street, Footscray
Tunbridge Wells	W. B. Jury Ltd., 73, Calverley Road
West Wickham	John Surtees Developments Ltd., 4, Bell Parade, Glebe Way

LANCASHIRE

Accrington	Bill Snape Ltd., 379, Blackburn Road
Blackburn	S. & G. Motorcycles (Blackburn) Ltd., 15-17, Great Bolton Street
Blackpool	J. Hall & Son (Blackpool) Ltd., 102-106, Devonshire Road
Bolton	Anderson Bros., Bradford Street
Burnley	C.S. Garages Ltd., 2, Gannow Top
Colne	Appleby Bros., Skipton Road
Lancaster	Wall & Sagar Ltd., 129-131, St. Leonardgate
Liverpool, 1	Victor Horsman Ltd., 65, Pembroke Place F. Llewellyn & Co. Ltd., 94-96, Whitechapel
Nelson	J. Hebden Ltd., 71, Scotland Road
Oldham	Alan Taylor (Northern) Ltd., 192, Manchester Street
Preston	Thomas Parish & Sons Ltd., 45, 52-62, Corporation Street
Radcliffe	Will Lord Ltd., 115, Blackburn Street
Salford, 3	Billy Briggs & Sons, 319, Chapel Street
Southport	Lifes Motors Ltd., West Street
St. Helens	Geoff Duke Ltd., Greenfield Road Garage
Stretford, Manchester	Kings Motors (Oxford) Ltd., 770, Chester Road
Widnes	Geneva Motors Ltd., 13-15, Victoria Road
Wigan	L. A. & S. M. Miller Ltd., 70-74, Scholes

LEICESTERSHIRE

Leicester	H. Petty & Sons, 22, Highfield Street Colmore Depot Ltd., 80, Belgrave Gate Kings Motors (Oxford) Ltd., Belgrave Gate Arbour Motors, 147, Melton Road
Loughborough	Colmore Depot Ltd., 138, Nottingham Road

LINCOLNSHIRE

Grimsby	Gresswells Garage, 13-15, Osborne St.
Holbeach	Gordon Woodman Ltd., 34, Fleet St.
Lincoln	West's (Lincoln) Ltd., 116, High Street
Scunthorpe	R. L. Ward (Motorcycles) Ltd., 18/22, High Street

MIDDLESEX

Edgware	Rex Judd Ltd., High Street
Harrow	E. T. Pink (Harrow) Ltd., Station Rd.
Hounslow	Stanley's Motors, 46-48, Lampton Rd.
Potters Bar	Stan Cameron & Alan Hogarth, M/c, 163, High Street
Staines	Eric Oliver Motorcycles Ltd., 99, London Road
Twickenham	Blays of Twickenham Ltd., 192, 199, Heath Road
Uxbridge	Miles Motors Ltd., 60, High Street

MONMOUTHSHIRE

Beaufort, Ebbw Vale	Beaufort Garage Co. (Ebbw Vale) Ltd.
Newport	Beechwood Motors (Newport) Ltd., 426, Chapscow Road

NORFOLK

Norwich, 71K Nor...	Chapmans (Norwich) Ltd., 38, 40-42, Duke Street
----------------------------	---

NORTHAMPTONSHIRE

Kettering	J. Bosworth & Sons, Dalkeith Place
Northampton	Spokes & Son Ltd., 1, Henry Street
Peterborough	Burrows Brothers, 55-57, Westgate

NORTHUMBERLAND

Ashington	J. Main & Sons (Ashington) Ltd., 1, Laburnum Terrace
Berwick on Tweed	Larry Forman & Co., 47-51, Walkergate
Newcastle-upon-Tyne, 1	Dene (Newcastle) Motor Co. Ltd., Haymarket

NOTTINGHAMSHIRE

Mansfield	Chas. E. Cope & Sons (Mansfield) Ltd., 2, Albert Street
Newark	Blacknell Motors Ltd., 17, North Gate
Nottingham	Hooleys Garage Ltd., Richmond House, Greyfriar Gate
Worksop	Ezra Sugden Ltd., 109, Gateford Road

OXFORDSHIRE

Banbury	North Bar Garage, North Bar
Oxford, 2	Kings Motors (Oxford) Ltd., New Rd.

SHROPSHIRE

Shrewsbury	Mr. J. C. Pickering, 49, Mardol
--------------------------	---------------------------------

SOMERSET

Bath	Barton Motors, 14, Westgate Buildings
Bridgwater	Anderson & Wall Ltd., 18, St. Mary Street
Bristol	Kings Motors (Oxford) Ltd., 16-17-18, North Street, Stokes Croft
Street	Jim Alves Ltd., 97, High Street
Taunton	W. P. Edwards (Motors) Ltd., Station Road
Weston-super-Mare	Wyverns of Weston Ltd., Locking Rd

STAFFORDSHIRE

Burton-upon-Trent ...	Hazlehurst Motors Ltd., 3-4, Watmore Road
Leek ...	Mr. Ron Desville, Mill Street
Lichfield ...	Lichfield Motor Cycle Depot, 37, Tamworth Street
Newcastle-under-Lyme ...	Chas. E. Cope & Sons Ltd., 12, George Street
Stoke-on-Trent ...	Broadway Motors, 34, Liverpool Road
Tamworth ...	The Motor Cycle Shop, 72/73, Balebridge Street
Walsall ...	Motor Cycle Marc (Walsall) Ltd., 12, Ablewell Street
Wolverhampton ...	Chas. E. Cope & Sons Ltd., 169, Stafford Street Joseph Devey & Co. Ltd., 50, Darlington Street

SUFFOLK

Ipswich ...	Revetts Ltd., 1, Berners Street
Leiston ...	A. C. Keeble & Son, Theberton
Lowestoft ...	Mr. R. Wright, 67-69, London Road South
Stowmarket ...	Revetts Ltd., Ipswich Street

SURREY

Croydon ...	Godfreys Ltd., 226-234, London Road
Epsom ...	Arthur Wheeler Ltd., 45, Waterloo Road Goodall Motorcycles Ltd., 55, South Street
Farnham ...	Heath Bros. (Frensham) Ltd., 82-84, East Street
Guildford ...	S. R. Jeffery & Son Ltd., 137, High St.
Richmond ...	Harwoods of Richmond Ltd., 14-16, Kew Foot Road
Sutton ...	W. F. Guiver Ltd., 18-24, Rosehill Parade
Thames Ditton ...	Comerfords Ltd., Oxford House, Portsmouth Road
West Croydon ...	A. Mylam & Co., 383, London Road
Weybridge ...	Lewis & Sons, 51, Church Street

SUSSEX

Bexhill-on-Sea ...	F. & E. Clark, 74, London Road
Brighton ...	Redhill Motors (Brighton) Ltd., 104, North Road
Crawley ...	Harold Lines (Crawley), 28, Boulevard
Eastbourne ...	Jempsons Ltd., 118-120, Seaside
Pulborough ...	Gray & Rowsell (Bury) Ltd., Burygate
Shoreham-by-Sea ...	Gray, Rowsell & Baker Ltd., Shoreham Motors, 1, Lower Road
Worthing ...	Gray & Rowsell (Worthing) Ltd., 56, Broadwater Street West

WARWICKSHIRE

Birmingham, 1 ...	Colmore Depot Ltd., 43-49, John Bright Street
17 ...	Chas. E. Cope & Sons Ltd., 477-487, Hagley Road, Edgbaston
6 ...	Premier Motor Co. (Birmingham) Ltd., Aston Road
12 ...	Shovelbottoms Ltd., 376, Ladypool Road, Taunton Rd. Cnr., Sparkbrook

Coventry ...	Albany Motorcycle Spares, 51, Warwick Road W. Brandish & Sons Ltd., Whitefriars Street F. J. Brown Motorcycles, 528/530, Stoney Stanton Road
--------------	--

Leamington ...	Vernon Pickering & Co., 2/4, Park St.
----------------	---------------------------------------

Nuneaton ...	Nuneaton Motor Cycle Depot, 61, Abbey Street
--------------	--

Stratford-upon-Avon ...	Mathews & Co. (Stratford-upon-Avon) Ltd., 31/32, Birmingham Road
-------------------------	--

WILTSHIRE

Salisbury ...	Pankhurst (Weymouth) Ltd., 78-79, Exeter Street
---------------	---

Swindon ...	The Swindon Motor Co. Ltd., 34, Wood Street
-------------	---

Trowbridge ...	F. Slaightholme & Sons Ltd., Newtown
----------------	--------------------------------------

WORCESTERSHIRE

Dudley ...	Chas. E. Cope & Sons Ltd., 98 & 193, High Street
------------	--

Worcester ...	Eric Williams Ltd., Pierpont Street
---------------	-------------------------------------

YORKSHIRE

Barnsley ...	Mr. George Ward, Doncaster Road
--------------	---------------------------------

Bradford ...	Myers Motorcycles Ltd., 52-62, Brear-ton Street, Manningham Lane
--------------	--

Dewsbury ...	Parkinsons (Wakefield) Ltd., 6, Bradford Road
--------------	---

Doncaster ...	Raynes Motors Ltd., 10, Cleveland St.
---------------	---------------------------------------

Goldthorpe ...	Mr. G. Wigfield, Furlong Garage
----------------	---------------------------------

Harrogate ...	Baines Brothers, 23, Station Parade
---------------	-------------------------------------

Huddersfield ...	G. A. Earnshaw Ltd., Manchester Rd. Arnold Moore (Motorcycles) Ltd., Oxford Street Garage, Northgate
------------------	---

Hull ...	Jordan & Co. (Hull) Ltd., Storey Street
----------	---

Leeds, 9 ...	Walter Wragg Ltd., Munro House, York Street
--------------	---

6 ...	W. Marsden & Son Ltd., Hyde Park Corner
-------	---

Middlesbrough ...	William Armstrong Ltd., 379-381, Linthorpe Road Dixons Motorcycles, 114, Newport Road
-------------------	--

Pontefract ...	Ewbank & Son Ltd., The Motorcycle Specialist
----------------	--

Rotherham ...	Mr. Ernest Cross, 55-59, Drummond Street
---------------	--

Scarborough ...	Andrew (Scarborough) Ltd., 149, Victoria Road
-----------------	---

Sheffield, 2 ...	Harridge & Wildgoose, 292, London Road
------------------	--

1 ...	Walter Wragg Ltd., Stanley Works, Wellington Street
-------	---

Shipley ...	Allan Jefferies, 120, Saltaire Road
-------------	-------------------------------------

Wakefield ...	W. Burrows & Sons, Newbridge Garage, Ings Road
---------------	--

York ...	J. D. Shearsmith Ltd., 43, Blossom St.
----------	--

LONDON

Acton	Whitbys of Acton Ltd., 273, The Vale, Acton, W.3
Ealing	Kays of Ealing, 8 & 10, Bond Street, Ealing, W.5
East Dulwich	Pullin's Motorcycles Ltd., 71-75, Lordship Lane, S.E.22
East Ham	E. E. Atkinson (Motors) Ltd., 415, Barking Road, East Ham, E.6 Godfrey's Ltd., 220, Barking Road, East Ham, E.6
Edmonton	E. S. Longstaff Ltd., 68, New Road, Edmonton, N.9
Eltham	Becketts of Eltham Ltd., 25, Courtyard, High Street, Eltham, S.E.9
Forest Hill	F. H. Brackpool & Co. Ltd., 226-228, Stanstead Road, Forest Hill, S.E.23
Greenwich	M. F. Sharland Ltd., 5, South Street, Greenwich, S.E.10.
Hackney	Eleanor Motors Ltd., 265-269, Mare Street, Hackney, E.8
Hammersmith	F. Freeman (Hammersmith) Ltd., 94, Hammersmith Bridge Rd., Hammersmith, W.6.
Hampstead	W. E. Humphreys Ltd., 116-122, Hampstead Road, N.W.1
Harringay	Banks, 62-64, Grand Parade, Harringay, N.4
Highgate	Gatehouse Motorcycles Ltd., 171-198 Archway Road, Highgate, N.6
Leyton	S. A. Coles Ltd., 364, High Road, Leyton, E.10
Neasden	Slocombs Ltd., 239-247, Neasden Lane, Neasden, N.W.10
North Finchley	Glanfield Lawrence Ltd., 407/9, High Road, Finchley, N.12
Peckham	Osgood & Coates Ltd., 781, 783, 785, Old Kent Road, Peckham, S.E.15
Plaistow	Sid Franklan, 480, Barking Road, Plaistow, E.13
Portland Street	Godfrey's Ltd., 208-210, Great Portland Street, W.1
Putney	Putney Autos Ltd., 263, Putney Bridge Road, Putney, S.W.13
South Lambeth	Harveys (Lambeth) Ltd., 47, South Lambeth Road, Lambeth, S.W.8
Stockwell	Gus Kuhn Motors Ltd., 275, Clapham Road, Stockwell, S.W.9 Pride & Clarke Ltd., 158, Stockwell Road, Stockwell, S.W.9

Tooting	Elite Motors Ltd., 951-961, Garratt Lane, Tooting Broadway, S.W.17 E. T. Hughes, 222, Tooting High Street, S.W.17
Tottenham	Moore's Motorcycles, 653, High Road, Tottenham, N.17
Woolwich	Cleare & Co. Ltd., 1, Woolwich High Street, London, S.E.18

CHANNEL ISLANDS

Guernsey	Mr. H. C. Tostevin, Grande Rue Motor & Cycle Works, St. Marcins
Jersey	Boudin's, 20, Bath Street, St. Helier

ISLE OF MAN

Douglas	Gilbert Harding, 21, Market Street
-----------------------	------------------------------------

NORTHERN IRELAND

Belfast	McIntyre Bros. (Belfast) Ltd., 50-56, May Street
Enniskillen, Co. Fermanagh	John Jeffers & Son, 36, East Bridge Street

SCOTLAND

Aberdeen	George Cheyne (Cycles) Ltd., 147-9, Holburn Street
Brechin	J. Duncan & Son, 3-5, St. Mary Street
Dundee	George McLean Ltd., 30, Ward Road
Edinburgh	Rossleigh Ltd., 39-45, Lothian Road
Glasgow, C.3	Bell Bros. (H.P.) Ltd., 215-229, St. Georges Road
Kirkcaldy, Fifeshire	A. E. Peatman & Sons, Thornton Road
Troon, Ayrshire	Cooper Bros., 117-129, Temple Hill

WALES

Caerphilly, Glam.	Cyril Morgan Motors Ltd., Piccadilly Square
Cardiff, Glam.	Robert Bevan & Sons, 29-35, Castle St.
Carmarthen	Eddie Stephens Motors, 22-23, Water Street
Llwhaden, Nr. Narbeth, Pembs.	J. Bowen & Sons Ltd., Llwhaden
Swansea	Mr. J. Brayley, 23, Dilwyn Street
Wrexham, Denbs.	Mr. J. Wilkinson, Yale Garage, Brook Street

ILLUSTRATION INDEX

<i>Fig. No.</i>	<i>Page No.</i>
1	18
2	20
3	22
4	24
5	26
6	28
7	30
8	32
9	34
10	36
11	38
12	40
13	42
14	44
15	46
16	48
17	50
18	52
19	54
20	56
21	58
22	60
23	62
24	64
25	66

INDEX

	Page		Page
AIR FILTER	53, 65	MUDGUARDS	55
ALTERNATIVE SPROCKETS	15	NACELLE	39
BATTERY CARRIER	53	OIL PUMP	27
CARBURETTER	63, 65	OIL TANK	51
CARTON PACKS	14	PETROL TANK	51
CENTRE STAND	33	PILLION FOOTRESTS	35
CHAINGUARDS	35	PISTONS	19
CHAINS	31	PROP STAND	33
CLUTCH	31	REAR PANELS	57
COIL	67	REAR WHEEL	49
CONTACT BREAKER	67	RECTIFIER	39
CONTROL CABLES	61	ROTOR	19
CONTROL LEVERS	59	SILENCERS	57
CRANKCASE	21, 23	SPARKING PLUGS	67
CRANKSHAFT	19	SPEEDOMETER	39, 43
CYLINDER HEAD	25	STATOR	67
ENGINE BOLTS	33	STEERING RACES	33
ENGINE SPROCKET	19	SUSPENSION UNITS	33
EXHAUST PIPES	57	SWITCHES	39, 43
FOOTRESTS	35	TACHOMETER	43
FRONT FORKS	37, 41	TIMING GEARS	19
FRONT WHEEL	45, 47	TOOLKIT	53
GASKET SETS	15	TWINSEAT	57
GEARBOX	29	VALVES	25
HANDLEBARS	59	WIRING HARNESS	39, 43
HORN	39, 43		

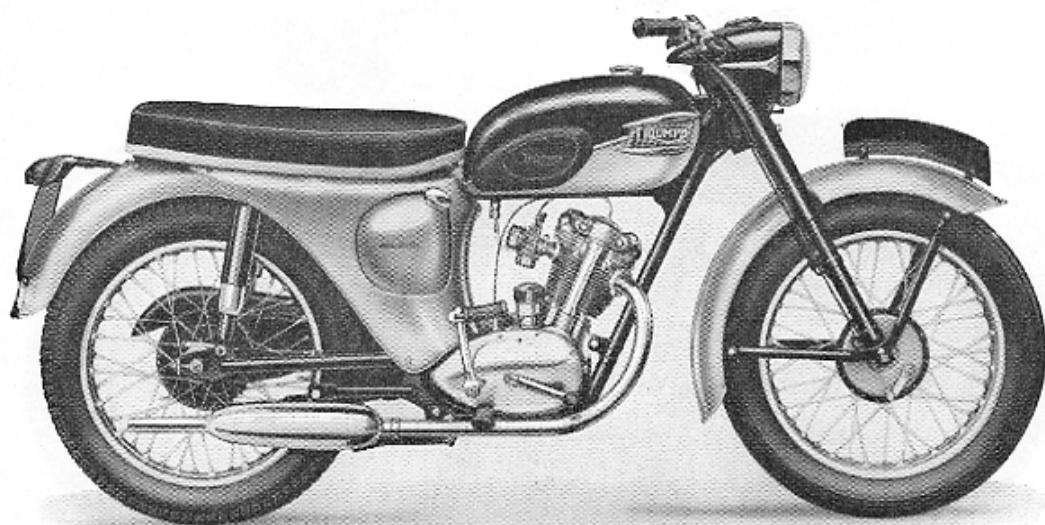

TIGER CUB (T20) TECHNICAL DATA

Bore and Stroke		63 x 64 mm. 2.480 x 2.520 ins.
Capacity		199 c.c. (12 cu. ins.).
Compression Ratio		7 : 1
Sparking Plug	Champion L7, K.L.G. F80 or Lodge HN.	
Carburetter	Zenith	
	Choke Size	18 mm.
	Main Jet	84
	Slow Running Jet	45
	Starter Slide	200/65
Gearbox Sprocket		17 teeth
Final Drive Sprocket		46 teeth
Chains	Front	$\frac{3}{8}$ in. x $\frac{7}{16}$ in. Duplex x 62 links
	Rear	$\frac{1}{2}$ in. x $\frac{11}{16}$ in. x 112 links
Capacities	Fuel Tank	3 galls. (13.5 litres)
	Oil Tank	$2\frac{3}{4}$ pints (1.55 litres)
	Gearbox	$\frac{1}{2}$ pint (200 c.c.)
	Primary Chaincase	$\frac{1}{2}$ pint (200 c.c.)
	Front Forks (each leg)	$\frac{1}{8}$ pint (75 c.c.)
Brakes	Front and Rear Diameter	$5\frac{1}{2}$ in. (13.97 cm.)
Tyre Size	Front and Rear	3.25 x 17

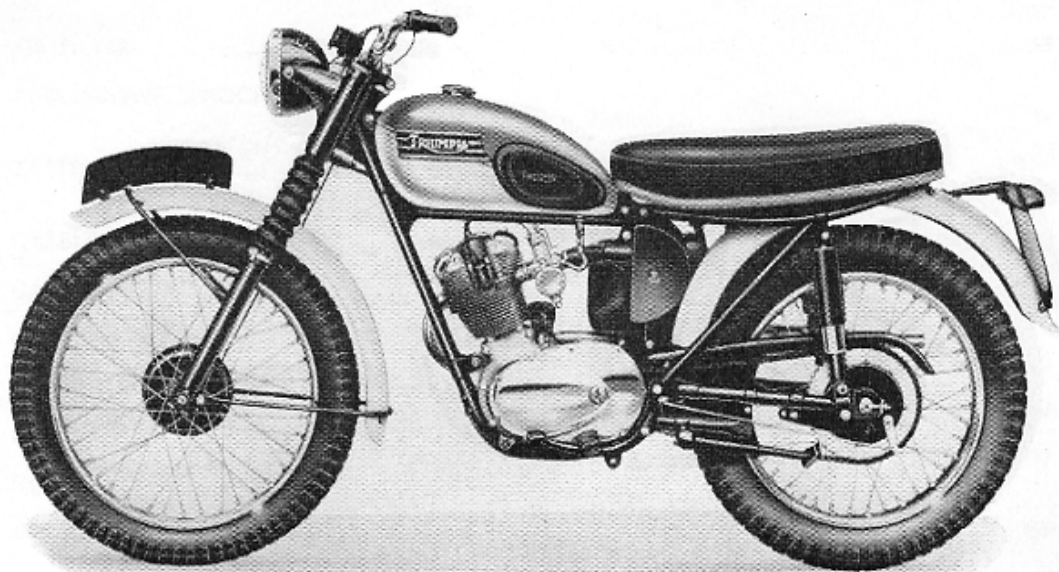

TIGER CUB (T20S AND T20SL) TECHNICAL DATA

Bore and Stroke		63 x 64 mm. 2.480 x 2.520 ins.
Capacity		199 c.c. (12 cu. ins.)
Compression Ratio		9 : 1
Sparking Plug	Champion L7, K.L.G. F80 or Lodge HN	
Carburettor	Amal Monobloc	
	Choke Size	$\frac{15}{16}$ in.
	Main Jet	140
	Needle Jet	.106
	Needle	Type C
	Throttle Valve	376/3
	Pilot Jet	20
Gearbox Sprocket		17 teeth
Final Drive Sprocket		48 teeth
Chains	Front	$\frac{3}{8}$ in. x $\frac{7}{32}$ in. Duplex x 62 links
	Rear	$\frac{1}{2}$ in. x $\frac{3}{16}$ in. x 113 links
Capacities	Fuel Tank	2 $\frac{5}{8}$ galls. (11.9 litres)
	Oil Tank	2 $\frac{1}{2}$ pints (1.55 litres)
	Gearbox	$\frac{1}{4}$ pint (200 c.c.)
	Primary Chaincase	$\frac{1}{4}$ pint (200 c.c.)
	Front Forks (each leg)	$\frac{1}{4}$ pint (150 c.c.)
Brakes	Front and Rear Diameter	5 $\frac{1}{2}$ in. (13.97 cm.)
Tyre Size	Front	3.00 x 19
	Rear	3.50 x 18

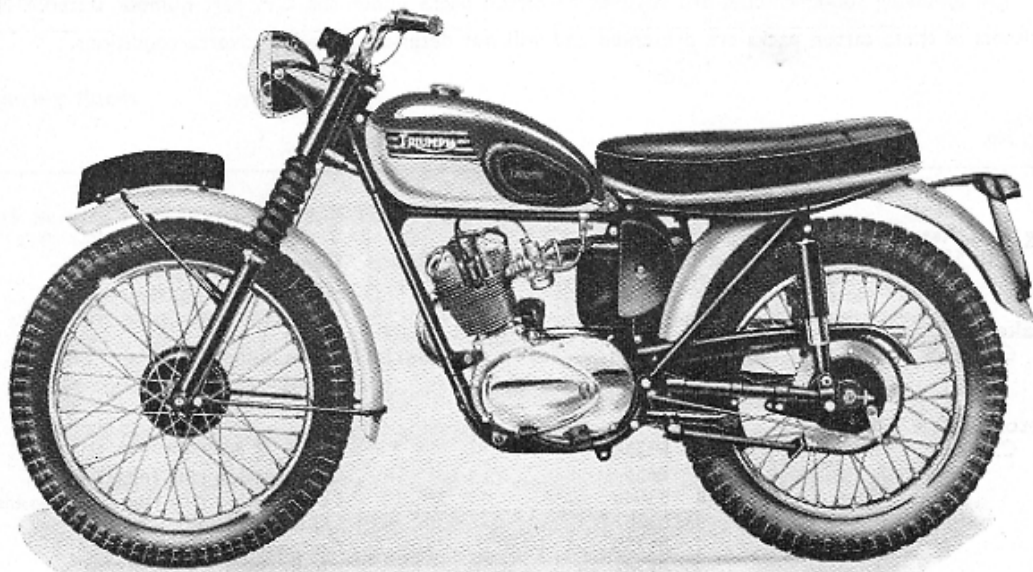

TIGER CUB (T20T) TECHNICAL DATA

Bore and Stroke		63 x 64 mm. 2.480 x 2.520 ins.
Capacity		199 c.c. (12 cu. ins.)
Compression Ratio		7 : 1
Sparking Plug	Champion L7, K.L.G. F.80 or Lodge HN	
Carburetter		Zenith
	Choke Size	18 mm.
	Main Jet	84
	Slow Running Jet	45
	Starter Slide	200/65
Gearbox Sprocket		16 teeth
Final Drive Sprocket		54 teeth
Chains	Front	$\frac{3}{8}$ in. x $\frac{7}{32}$ in. Duplex x 62 links
	Rear	$\frac{1}{2}$ in. x $\frac{1}{16}$ in. x 116 links
Capacities	Fuel Tank	2 $\frac{3}{4}$ galls. (11.9 litres)
	Oil Tank	2 $\frac{3}{4}$ pints (1.55 litres)
	Gearbox	$\frac{1}{2}$ pint (200 c.c.)
	Primary Chaincase	$\frac{1}{2}$ pint (200 c.c.)
	Front Forks (each leg)	$\frac{1}{4}$ pint (150 c.c.)
Brakes	Front and Rear Diameter	5 $\frac{1}{2}$ in. (13.97 cm.)
Tyre Size	Front	3.00 x 19
	Rear	3.50 x 18

CARTON PACK LIST

The following sub-assemblies are supplied in carton packs under the C.P. part number stated. The contents of these carton packs are preserved and will not deteriorate under adverse conditions.

Part No.		Contents
Big End Assembly		
C.P. 155	1 E3624	Connecting rod
	1 E3600	Crankpin
Brake Linings		
C.P. 128	2 W978	Brake linings
	14 W979	Rivets
Piston (T20 & T20T)		
C.P. 141	1 E3358	Piston, C.R. 7 : 1
	1 E656	Compression ring (plain)
	1 E3048	Compression ring (taper)
	1 E3387	Oil control ring
	1 E1750	Gudgeon pin
	2 E1767	Circlip
Piston Rings (T20 & T20T)		
C.P. 150	1 E656	Compression ring (plain)
	1 E3048	Compression ring (taper)
	1 E3387	Oil control ring
Piston (T20S & T20SL)		
C.P. 172	1 E3958	Piston, C.R. 9 : 1
	1 E3959	Compression ring (plain)
	1 E3960	Compression ring (taper)
	1 E3961	Oil control ring
	1 E1750	Gudgeon pin
	2 E1767	Circlip
Piston Rings (T20S & T20SL)		
C.P. 178	1 E3959	Compression ring (plain)
	1 E3960	Compression ring (taper)
	1 E3961	Oil control ring
Valve Guides		
C.P. 122	2 E3208	Valve guide
	2 E3209	Circlip
Valves		
C.P. 186	1 E3963	Inlet valve
	1 E3147	Exhaust valve
Valve Springs (T20 & T20T)		
C.P. 123	2 E3214	Inner valve spring
	2 E3215	Outer valve spring
Valve Springs (T20S & T20SL)		
C.P. 185	2 E3965	Inner valve spring
	2 E3966	Outer valve spring

CARTON PACK LIST — continued

Part No.			Contents
Steering Races			
C.P. 129	2	H835	Cup
	2	H833	Cone
	30	S70-3	Steel ball ($\frac{1}{2}$ in. diam.)
Fork Service Pack (T20S, T20SL & T20T)			
C.P. 168	2	H420	Rubber washer
	4	H430	Fibre washer
	2	H441	Upper bearing
	2	H443	Lower bearing
	2	H1062	Aluminium washer
	2	H1168	Oil seal

Gasket Set	GS	T20/59	All models

ALTERNATIVE SPROCKETS

Gearbox		Rear Wheel	
T1555/13	13 teeth	W1320	46 teeth
T1555/14	14 teeth	W984	48 teeth
T1555/15	15 teeth	W1074	50 teeth
T1513/16	16 teeth	W1075	52 teeth
T1513/17	17 teeth	W1076	54 teeth
T1513/18	18 teeth	W1078	58 teeth
T1568	19 teeth		

PLEASE NOTE

THROUGHOUT THIS LIST, ASSEMBLIES ARE PRINTED IN CAPITALS AND THE COMPONENTS INCLUDED IN THAT ASSEMBLY ARE INDENTED IN THE DESCRIPTION COLUMN, REVERTING TO THE ORIGINAL ALIGNMENT WHEN THE ASSEMBLY IS COMPLETE. TO ORDER THE COMPLETE ASSEMBLY IT IS NECESSARY ONLY TO QUOTE THE ASSEMBLY NUMBER. ANY COMPONENT PARTS LISTED MAY ALSO BE OBTAINED SEPARATELY, IF REQUIRED.

SPECIAL WORKSHOP TOOLS

A COMPLETE LIST OF WORKSHOP TOOLS CAN BE MADE AVAILABLE BY EITHER CONTACTING YOUR DEALER OR APPLYING DIRECT TO THE TRIUMPH SERVICE DEPARTMENT. IN MOST CASES THESE TOOLS ARE VERY COSTLY AS THEY ARE MADE ENTIRELY FOR WORKSHOP USE, AND THEREFORE, IT IS NOT RECOMMENDED THAT THE PRIVATE OWNER PURCHASE THE TOOLS IN ORDER TO AID SERVICING THE MACHINE ONCE OR TWICE ONLY. IN THESE CIRCUMSTANCES IT IS FAR MORE ECONOMICAL TO GET IN TOUCH WITH A RECOGNISED DEALER.

CRANKSHAFT ASSEMBLY. Ref. No. 1

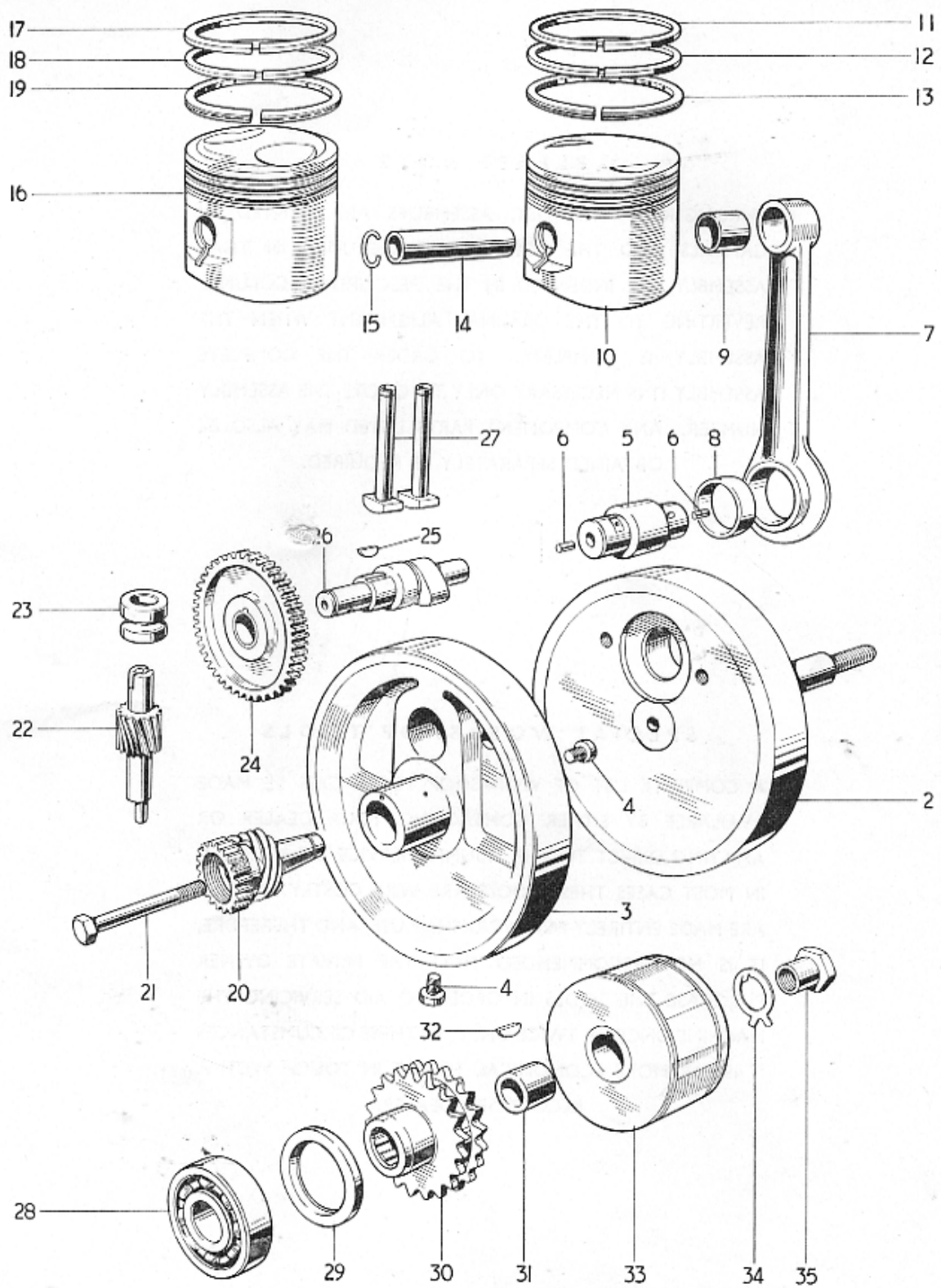

Fig. 1. CRANKSHAFT, PISTON AND TIMING GEARS

CRANKSHAFT, PISTON AND TIMING GEARS

							T20	T20S	T20SL	T20T
1	E3909	CRANKSHAFT ASSEMBLY	1	1	1	1
2	E3910	Left flywheel	1	1	1	1
3	E3598	RIGHT FLYWHEEL	1	1	1	1
4	E3420	Oilway plug	2	2	2	2
5	E3600	CRANKPIN	1	1	1	1
6	E3292	Oilway plug	2	2	2	2
7	E3624	CONNECTING ROD	1	1	1	1
8	E3623	Big end bush (Export only)	1	1	1	1
9	E1762	Small end bush	1	1	1	1
10	C141	PISTON COMPLETE, C.R. 7 : 1	1	-	-	1
11	E656	Compression ring	1	-	-	1
12	E3048	Taper compression ring	1	-	-	1
13	E3387	Oil control ring	1	-	-	1
14	E1750	Gudgeon pin	1	-	-	1
15	E1767	Circlip	2	-	-	2
16	CP172	PISTON COMPLETE, C.R. 9 : 1	-	1	1	-
17	E3959	Compression ring	-	1	1	-
18	E3960	Taper compression ring	-	1	1	-
19	E3961	Oil control ring	-	1	1	-
14	E1750	Gudgeon pin	-	1	1	-
15	E1767	Circlip	-	2	2	-
20	E4079	Timing pinion	1	1	1	1
21	E3421	Bolt (1 $\frac{13}{32}$ in. U.H.)	1	1	1	1
22	E3186	Distributor and oil pump drive shaft	1	1	1	1
23	E4190	Distributor shaft bush	1	1	1	1
24	E3185	Camshaft pinion	1	1	1	1
25	E3184	Camshaft key	1	1	1	1
26	E3183	Camshaft	1	-	-	1
26	E3962	Camshaft	-	1	1	-
27	E3285	Tappet	2	2	2	2
28	E3152	Left main bearing	1	1	1	1
29	E3379	Oil seal	1	1	1	1
30	E3912	Engine sprocket (26 teeth Duplex)	1	1	1	1
31	E3913	Distance piece	1	1	1	1
32	E1580	Key	1	1	1	1
33	466124	Rotor	1	1	1	1
34	E4058	Tab washer	1	1	1	1
35	E3971	Nut	1	1	1	1

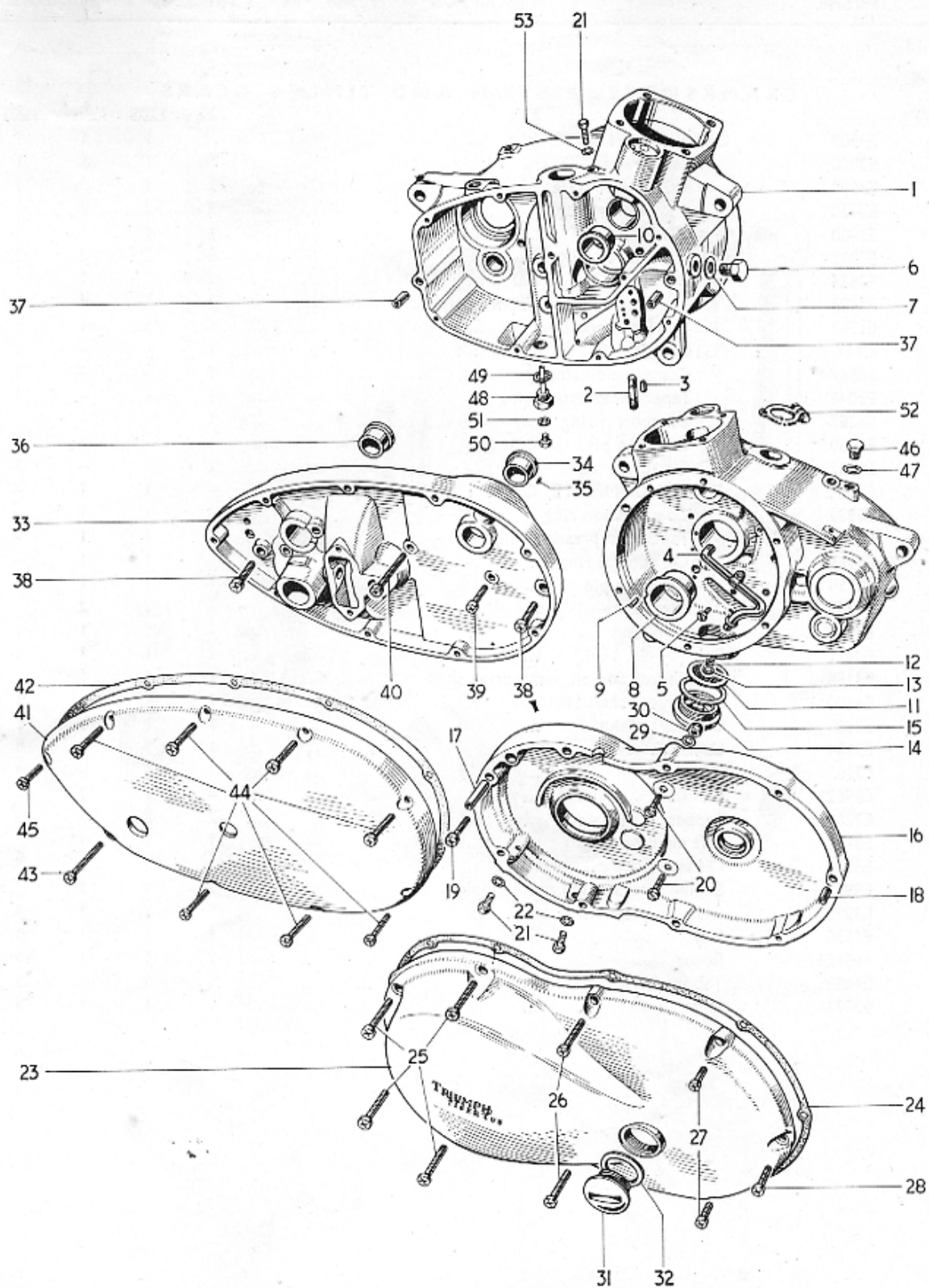

Fig. 2. CRANKCASE (ONE-PIECE) UP TO ENGINE No. 57616

CRANKCASE (ONE-PIECE) UP TO ENGINE NO. 57616

			T20	T20S
1	E3930	CRANKCASE	1	1
2	E3171	Oil junction block stud	1	1
3	E3169	Oil junction block dowel	1	1
4	E3560	Oil scavenge pipe	1	1
5	T1076	Screw ($\frac{3}{8}$ in. U.H.)	1	1
6	E2615	Screwed plug	1	1
7	E1335	Copper washer	1	1
8	E3655	Right main bearing	1	1
9	E3172	Peg	1	1
10	E3175	Camshaft bush	1	1
11	E3177	Crankcase filter	1	1
12	E3176	Spring	1	1
13	E3302	Plain washer	1	1
14	E1564	Filter cover	1	1
15	E1577	Fibre washer	1	1
16	E3915	LEFT INNER COVER	1	1
17	T1492	Front dowel	1	1
18	T989	Rear dowel	1	1
19	E3204	Screw (1 in. U.H.)	1	1
20	E3445	Screw ($\frac{11}{16}$ in. U.H.)	2	2
21	DS57	Drain and level plug	3	3
22	WE170	Fibre washer	2	2
23	E3917	Left outer cover	1	1
24	E3597	Joint washer	1	1
25	E3914	Screw ($1\frac{1}{4}$ in. U.H.)	4	4
26	E3205	Screw ($1\frac{1}{2}$ in. U.H.)	2	2
27	E3200	Screw ($\frac{11}{8}$ in. U.H.)	2	2
28	E3204	Screw (1 in. U.H.)	1	1
29	E2441	Copper washer	2	2
30	E2386	Domed nut	2	2
31	E732	Oil filler plug	1	1
32	NE507	Fibre washer	1	1
33	E3476	RIGHT INNER COVER C/W CLUTCH LEVER	1	1
34	E3293	Camshaft bush	1	1
35	E3172	Peg	1	1
36	T1147	Mainshaft bush	1	1
37	T989	Dowel	2	2
38	E3204	Screw (1 in. U.H.)	2	2
39	E3220	Screw ($\frac{11}{16}$ in. U.H.)	1	1
40	E3221	Screw ($1\frac{1}{8}$ in. U.H.)	1	1
41	E3151	Right outer cover	1	1
42	E3345	Joint washer	1	1
43	E3221	Screw ($1\frac{1}{8}$ in. U.H.)	1	1
44	E3231	Screw ($1\frac{3}{8}$ in. U.H.)	7	7
45	E3220	Screw ($\frac{11}{16}$ in. U.H.)	1	1
46	T1110	Gearbox filler plug	1	1
47	E697	Fibre washer	1	1
48	T1112	Gearbox drain plug with level tube	1	1
49	T1257	Fibre washer	1	1
50	T361	Gearbox level plug	1	1
51	WE170	Fibre washer	1	1
52	406105	Clamp plate	1	1
53	S25-13	Plain washer	1	1

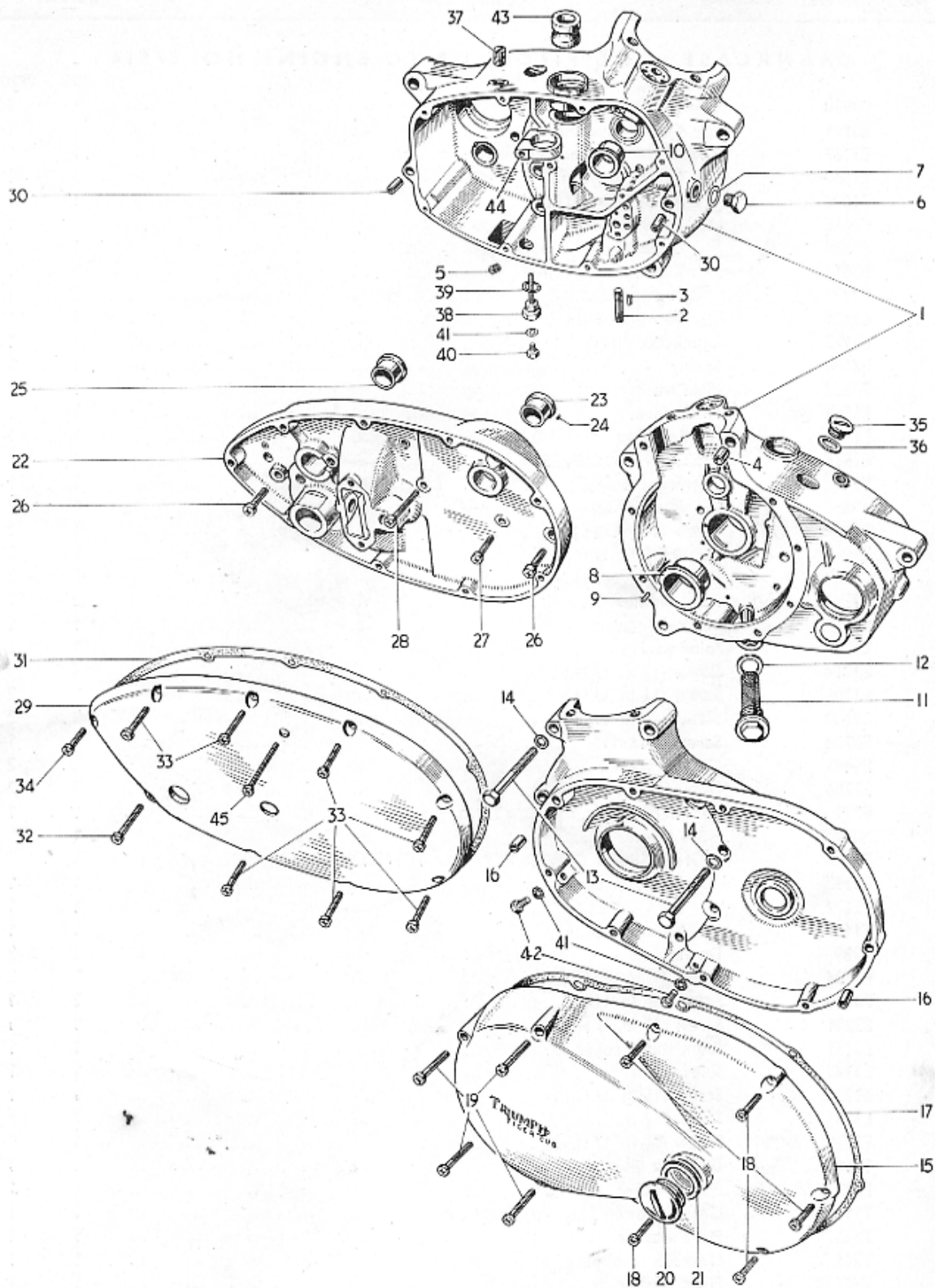

Fig. 3. CRANKCASE (TWO-PIECE) FROM ENGINE No. 57617

CRANKCASE (TWO-PIECE) FROM ENGINE NO. 57617

								T20	T20S	T20SL	T20T
1	E4087/8	CRANKCASE	1	1	1	1
2	E3171	Oil junction block stud	1	1	1	1
3	E3169	Oil junction block dowel	1	1	1	1
4	E4121	Crankcase joint dowel	1	1	1	1
5	E4104	Oilway plug	1	1	1	1
6	E2615	Screwed plug	1	1	1	1
7	E1335	Copper washer	1	1	1	1
8	† E3655	Right main bearing	1	1	1	1
9	E3172	Peg	1	1	1	1
10	E3175	Camshaft bush	1	1	1	1
11	E4094	Crankcase filter	1	1	1	1
12	E2570	Fibre washer	1	1	1	1
13	E4098	Bolt (1 $\frac{7}{8}$ in. U.H.)	9	9	9	9
14	S25-3	Plain washer	9	9	9	9
15	E4089	Left outer cover	1	1	1	1
16	T989	Dowel	2	2	2	2
17	E4100	Joint washer	1	1	1	1
18	E3204	Screw (1 in. U.H.)	5	5	5	5
19	E4096	Screw (2 $\frac{3}{16}$ in. U.H.)	4	4	4	4
20	E732	Oil filler plug	1	1	1	1
21	NE507	Fibre washer	1	1	1	1
22	E4090	RIGHT INNER COVER	1	1	1	1
23	E3293	Camshaft bush	1	1	1	1
24	E3172	Peg	1	1	1	1
25	T1147	Mainshaft bush	1	1	1	1
26	E3204	Screw (1 in. U.H.)	2	2	2	2
27	E3220	Screw (1 $\frac{1}{8}$ in. U.H.)	1	1	1	1
28	E3221	Screw (1 $\frac{1}{8}$ in. U.H.)	1	1	1	1
29	E4092	Right outer cover	1	1	1	1
30	T989	Dowel	2	2	2	2
31	E3345	Joint washer	1	1	1	1
32	E3221	Screw (1 $\frac{7}{8}$ in. U.H.)	1	1	1	1
33	E3231	Screw (1 $\frac{3}{8}$ in. U.H.)	7	7	7	7
34	E3220	Screw (1 $\frac{1}{8}$ in. U.H.)	1	1	1	1
35	T1599	Gearbox filler plug	1	1	1	1
36	E1465	Fibre washer	1	1	1	1
37	E4048	Blanking plug	-	1	1	1
38	T1112	Gearbox drain plug with level tube	1	1	1	1
39	T1257	Fibre washer	1	1	1	1
40	T361	Gearbox level plug	1	1	1	1
41	WE170	Fibre washer	3	3	3	3
42	DS57	Drain and level plug	2	2	2	2
43	E4190	Distributor shaft bush	1	1	1	1
44	E4099	Distributor clamp	1	1	1	1
45	E4097	Screw (2 $\frac{1}{4}$ in. U.H.)	1	1	1	1

† After Engine No. 69157 use E 3655 A

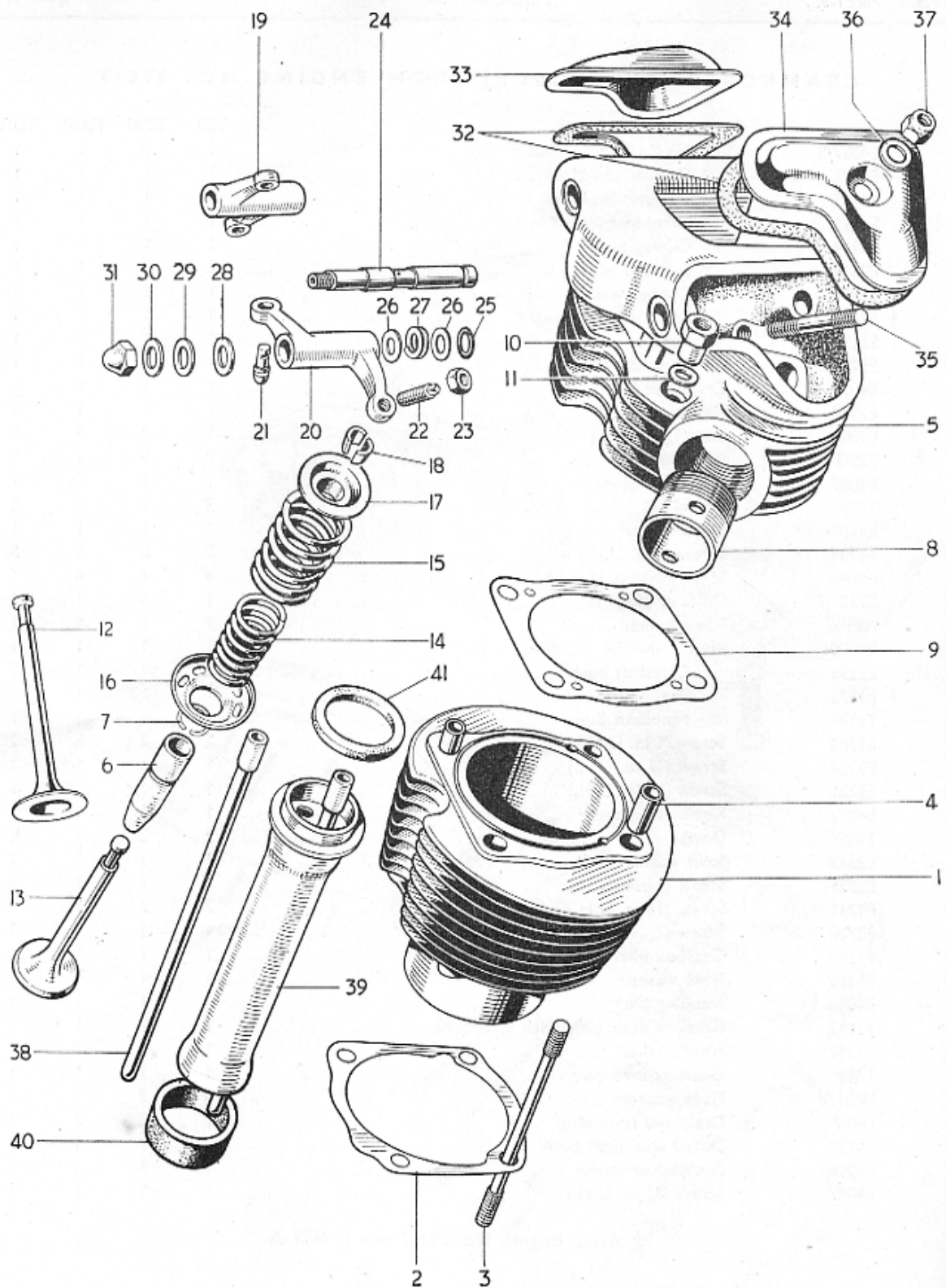

Fig. 4. CYLINDER BARREL AND HEAD

CYLINDER BARREL AND HEAD

			T20	T20S	T20SL	T20T
1	E3385	Cylinder barrel	1	1	1	1
2	E4037	Cylinder base washer	1	1	1	1
3	E3170	Crankcase to cylinder head stud ($4\frac{1}{32}$ in. O.A.)	4	4	4	4
4	E3386	Cylinder head dowel	2	2	2	2
5	E4101	CYLINDER HEAD C/W GUIDES	1	-	-	-
5	E4049A	CYLINDER HEAD C/W GUIDES	-	1	1	1
6	E3208	Valve guide	2	2	2	2
7	E3209	Valve guide circlip	2	2	2	2
8	E3207	Exhaust pipe adaptor	1	1	1	1
9	E3217	Cylinder head gasket	1	1	1	1
10	E4103	Nut	4	4	4	4
11	E3446	Plain washer	4	4	4	4
12	E3963	Inlet valve	1	1	1	1
13	E3147	Exhaust valve	1	1	1	1
14	E3214	Inner valve spring	2	-	-	2
14	E3965	Inner valve spring	-	2	2	-
15	E3215	Outer valve spring	2	-	-	2
15	E3966	Outer valve spring	-	2	2	-
16	E3213	Bottom cup	2	-	-	2
16	E3964	Bottom cup	-	2	2	-
17	E3301	Top collar	2	2	2	2
18	WE259A	Split cotter	4	4	4	4
19	E3251	INLET ROCKER	1	1	1	1
20	E3252	EXHAUST ROCKER	1	1	1	1
21	E3222	Rocker ball pin	2	2	2	2
22	E3223	Adjuster pin	2	2	2	2
23	GS662	Nut	2	2	2	2
24	E3225	Rocker spindle	2	2	2	2
25	E3253	Sealing ring	2	2	2	2
26	E2534	Thrust washer $\frac{7}{16}$ in.	4	4	4	4
27	E3224	Thackeray washer	2	2	2	2
28	E2594	Thrust washer $\frac{3}{8}$ in.	2	2	2	2
29	E1335	Copper washer $\frac{3}{8}$ in.	2	2	2	2
30	E3249	Copper washer $\frac{5}{16}$ in.	2	2	2	2
31	H400	Domed nut	2	2	2	2
32	E3226	Joint washer	2	2	2	2
33	E3227	Inlet rocker cover	1	1	1	1
34	E3228	Exhaust rocker cover	1	1	1	1
35	E3210	Stud ($2\frac{5}{32}$ in. O.A.)	2	2	2	2
36	E2441	Copper washer	2	2	2	2
37	E3290	Self locking nut	2	2	2	2
38	E3372	Push rod	2	2	2	2
39	E3537	Cover tube	1	1	1	1
40	E3391	Lower joint washer	1	1	1	1
41	E3540	Upper joint washer	1	1	1	1

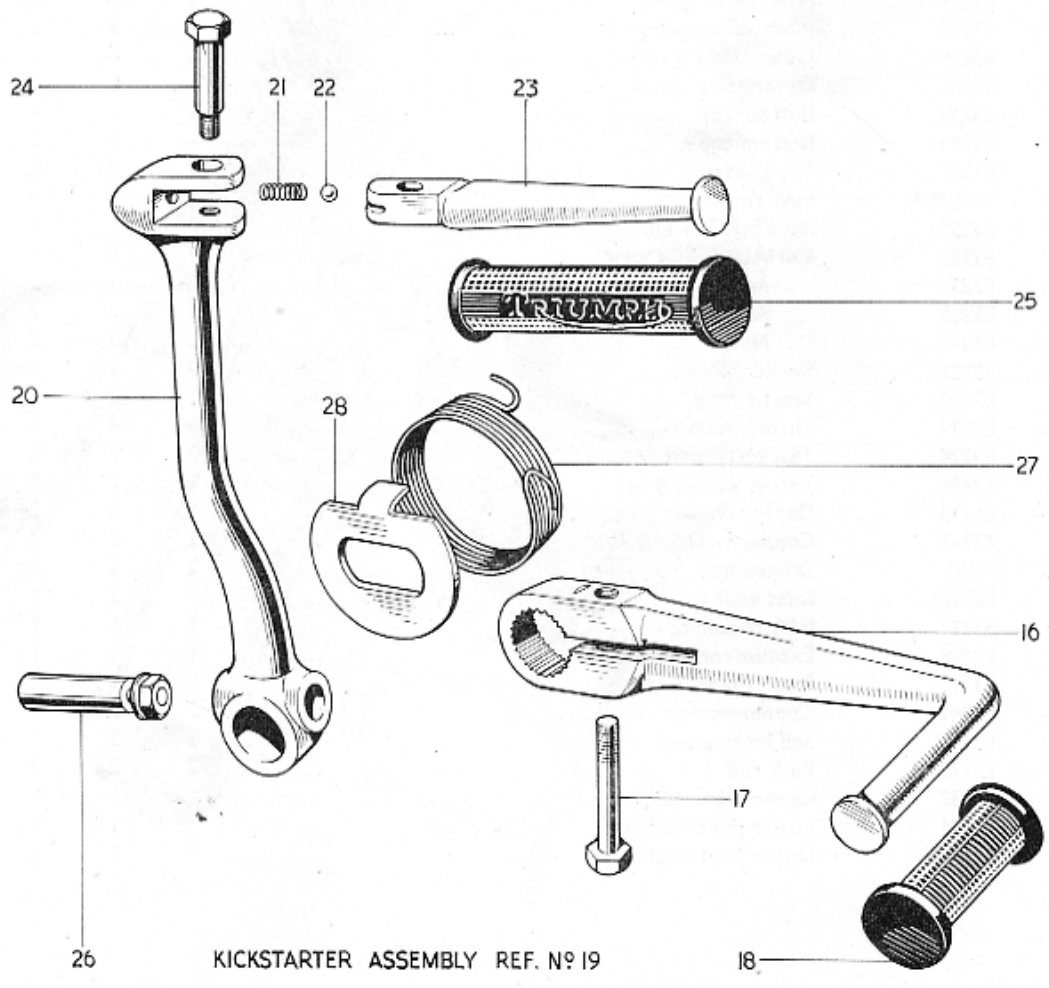
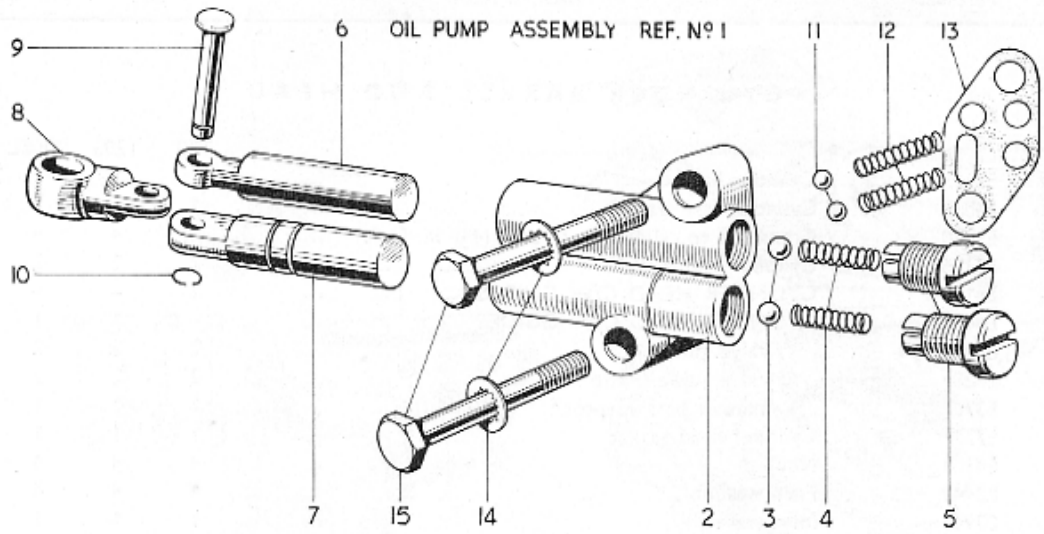

Fig. 5. OIL PUMP AND CONTROL PEDALS

OIL PUMP AND CONTROL PEDALS

							T20	T20S	T20SL	T20T
1	E4208	OIL PUMP ASSEMBLY	1	1	1	1
2	E4209	Pump body	1	1	1	1
3	S70-4	Steel ball ($\frac{3}{16}$ in. diam.)	2	2	2	2
4	E3191	Spring	2	2	2	2
5	E4212	Plug	2	2	2	2
6	E4210	Feed plunger	2	2	2	2
7	E4211	Scavenge plunger	1	1	1	1
8	E3195	Connecting rod	1	1	1	1
9	E3412	Pin	1	1	1	1
10	E3413	Circlip	1	1	1	1
Prior to Engine Number 69157 when parts are required separately use										
1	E3393	OIL PUMP ASSEMBLY	1	1	1	1
2	E3409	Pump body	1	1	1	1
6	E3410	Feed plunger	1	1	1	1
7	E3194	Scavenge plunger	1	1	1	1
11	T1124	Auxiliary valve ball ($\frac{5}{32}$ in. diam.)	2	2	2	2
12	E3191	Spring	2	2	2	2
13	E3188	Joint washer	1	1	1	1
14	GS299	Serrated washer	2	2	2	2
15	E3197	Bolt ($\frac{1}{8}$ in. U.H.)	2	2	2	2
16	T1164	Gearchange pedal	1	1	1	1
17	F1369	Bolt ($\frac{5}{8}$ in. U.H.)	1	1	1	1
18	T449	Pedal rubber	1	1	1	1
19	T1230	KICKSTARTER ASSEMBLY	1	1	1	1
20	T1166	Crank	1	1	1	1
21	T1167	Spring	1	1	1	1
22	S70-3	Steel ball ($\frac{1}{4}$ in. diam.)	1	1	1	1
23	T1168	Pedal	1	1	1	1
24	T1169	Pivot bolt	1	1	1	1
25	F1814	Pedal rubber	1	1	1	1
26	S52-1	Cotter pin c/w nut and washer	1	1	1	1
27	T1162	Kickstarter return spring	1	1	1	1
28	T1163	Return spring plate	1	1	1	1

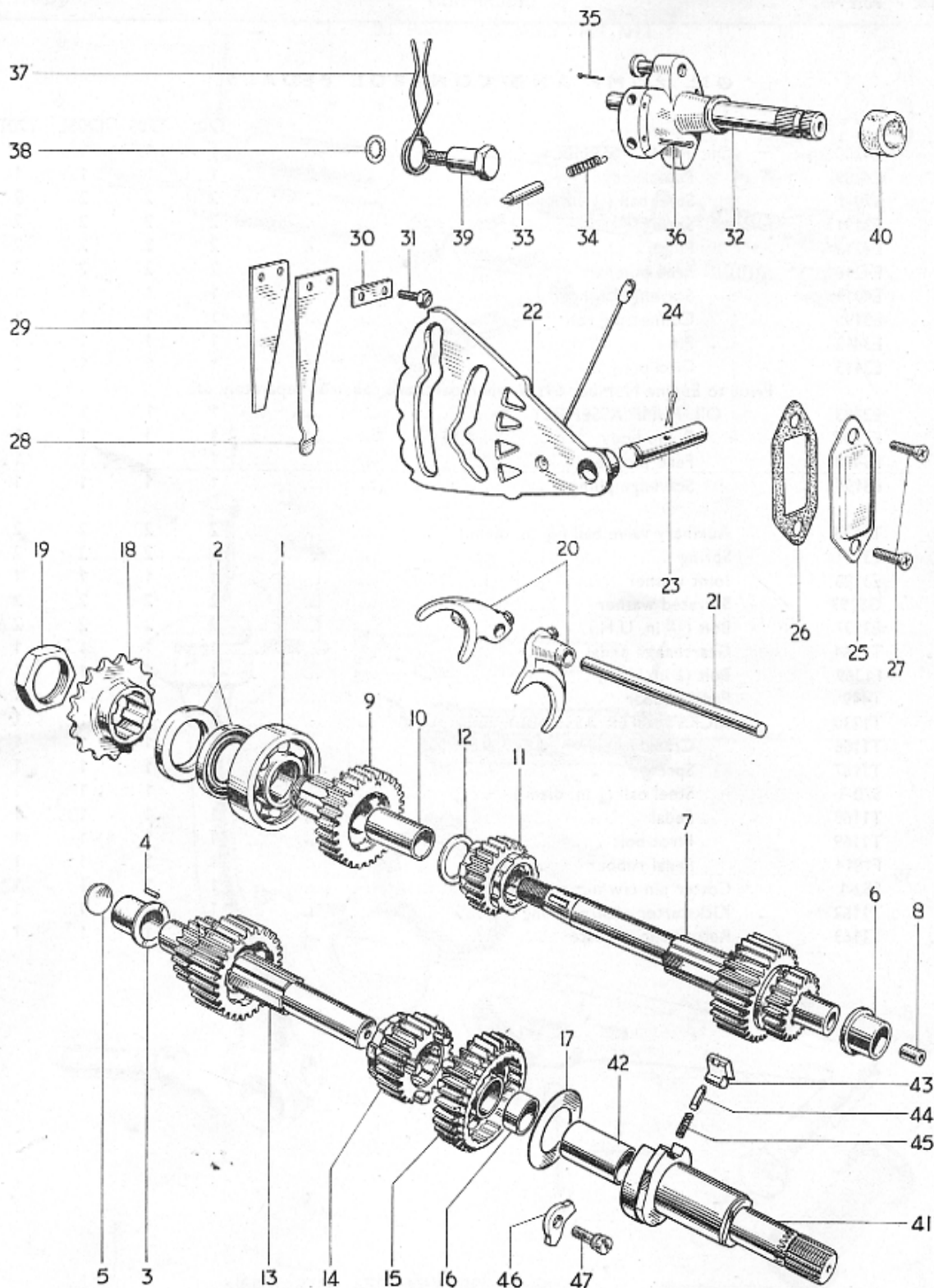

Fig. 6. GEARBOX SHAFTS AND GEARS

GEARBOX SHAFTS AND GEARS

			T20	T20S	T20SL	T20T
1	T1070	High gear bearing	1	1	1	1
2	H1168	Oil seal	2	2	2	2
3	T1073	Layshaft bearing bush	1	1	1	1
4	E3172	Peg	1	1	1	1
5	T1269	Blanking disc	1	1	1	1
6	T1147	Mainshaft bush	1	1	1	1
7	T1588	MAINSHAFT CLUSTER	1	1	1	1
8	T1085	Clutch rod bush	1	1	1	1
9	T1514	HIGH GEAR (28T)	1	-	-	-
9	T1565	HIGH GEAR (27T)	-	1	1	-
9	T1596	HIGH GEAR (29T)	-	-	-	1 X
10	T1515	High gear bush	1	1	1	1
11	T1089	Mainshaft second gear	1	1	1	1
12	T1090	Mainshaft thrust ring	1	1	1	1
13	T1591	Layshaft cluster (17T)	1	-	-	-
13	T1594	Layshaft cluster (18T)	-	1	1	-
13	T1602	Layshaft cluster (16T)	-	-	-	1 X
14	T1094	Layshaft third gear	1	1	1	1
15	T1095	LAYSHAFT LOW GEAR	1	1	1	1
16	T1097	Low gear bush	1	1	1	1
17	T1274	Pawl retaining disc	1	1	1	1
18	T1513/17	Gearbox sprocket (17 teeth)	1	1	1	-
18	T1513/16	Gearbox sprocket (16 teeth)	-	-	-	1 X
19	T1082	Sprocket nut	1	1	1	1
20	T1098	Selector fork	2	2	2	2
21	T1102	Selector fork spindle	1	1	1	1
22	T1066	Camplate	1	1	1	1
23	T1069	Camplate spindle	1	1	1	1
24	$\frac{3}{16} \times \frac{3}{8}$ in.	Split pin	1	1	1	1
25	T1149	Cover plate	1	1	1	1
26	T1148	Joint washer	1	1	1	1
27	T1150	Screw (0.41 in. U.H.)	2	2	2	2
28	T1248	Index spring	1	1	1	1
29	T1249	Supplementary index spring	1	1	1	1
30	T1180	Lockplate	1	1	1	1
31	T1076	Screw ($\frac{3}{8}$ in. U.H.)	2	2	2	2
32	T1259	GEARCHANGE QUADRANT	1	1	1	1
33	T1184	Plunger	2	2	2	2
34	T1278	Spring	2	2	2	2
35	T1277	Peg	2	2	2	2
36	$\frac{5}{16}$ in. x $\frac{3}{8}$ in.	Split pin	2	2	2	2
37	T1109	Return spring	1	1	1	1
38	E2287	Serrated washer	1	1	1	1
39	T1077	Bolt	1	1	1	1
40	T1181	Felt washer	1	1	1	1
41	T1279	KICKSTARTER SPINDLE	1	1	1	1
42	T1118	Bush	1	1	1	1
43	T1281	Pawl	1	1	1	1
44	T1282	Plunger	1	1	1	1
45	T1161	Spring	1	1	1	1
46	T1157	Stop plate	1	1	1	1
47	T1158	Screw	1	1	1	1

OPERATING LEVER ASSEMBLY REF. N° 1
CLUTCH COMPLETE REF. N° 13

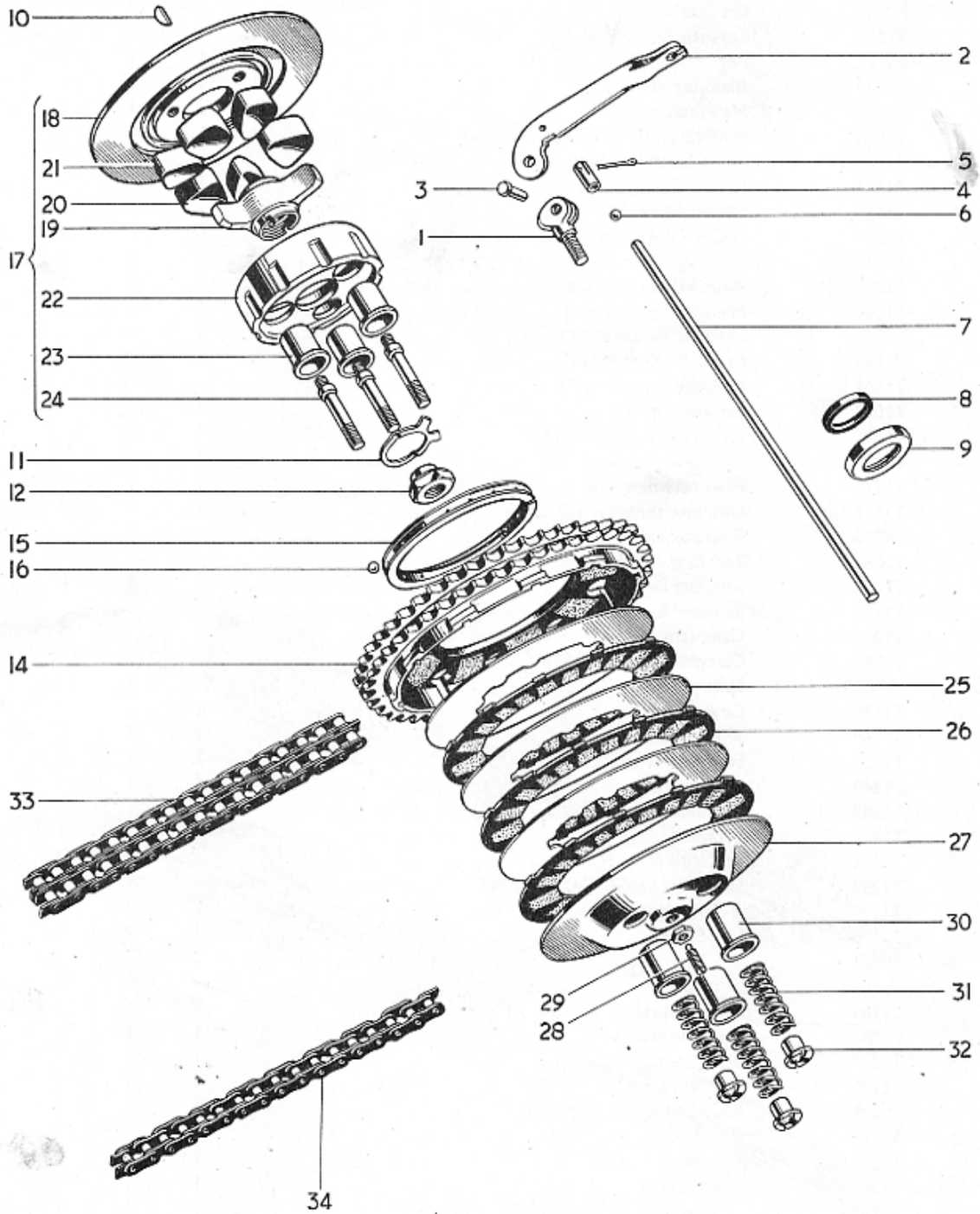

Fig. 7. CLUTCH AND CHAINS

CLUTCH AND CHAINS

							T20	T20S	T20SL	T20T
1	T1233	CLUTCH OPERATING LEVER ASSEMBLY	1	1	1	1
2	T1235	Lever	1	1	1	1
3	T1236	Pin	1	1	1	1
4	T1155	Cup	1	1	1	1
5	$\frac{1}{16}$ in. x $\frac{3}{8}$ in.	Split pin	1	1	1	1
6	T1124	Steel ball ($\frac{3}{32}$ in. diam.)	1	1	1	1
7	T1140	Clutch operating rod	1	1	1	1
8	E3932	Mainshaft oil seal	1	1	1	1
9	E3933	Oil seal retainer	1	1	1	1
10	T1119	Key	1	1	1	1
11	T1347	Tab washer	1	1	1	1
12	T1348	Nut	1	1	1	1
13	T1493	CLUTCH COMPLETE	1	1	1	1
14	T1509	Sprocket and housing (48 teeth)	1	1	1	1
15	T1264	Bearing ring	1	1	1	1
16	T1124	Steel ball ($\frac{3}{32}$ in. diam.)	16	16	16	16
17	T1345	SHOCK ABSORBER	1	1	1	1
18	T1128	Back plate	1	1	1	1
19	T1346	Spider	1	1	1	1
20	T1132	Drive rubber (large)	3	3	3	3
21	T1318	Rebound rubber (small)	3	3	3	3
22	T1314	Centre	1	1	1	1
23	T1364	Cup	3	3	3	3
24	T1350	Pin	3	3	3	3
25	T1315	Driven plate	3	3	3	3
26	T1503	Driving plate c/w linings	3	3	3	3
27	T1253	Pressure plate	1	1	1	1
28	T1256	Adjuster	1	1	1	1
29	GS662	Nut	1	1	1	1
30	T1144	Cup	3	3	3	3
31	T1145	Spring	3	3	3	3
32	T1146	Nut	3	3	3	3
33	D382	Primary chain ($\frac{3}{8}$ in. Duplex x 62 links)	1	1	1	1
34	D277	Rear chain ($\frac{1}{2}$ in. x $\frac{3}{16}$ in. x 112 links)	1	-	-	-
34	D431	Rear chain ($\frac{1}{2}$ in. x $\frac{3}{16}$ in. x 113 links)	-	1	1	-
34	D341	Rear chain ($\frac{1}{2}$ in. x $\frac{3}{16}$ in. x 116 links)	-	-	-	1

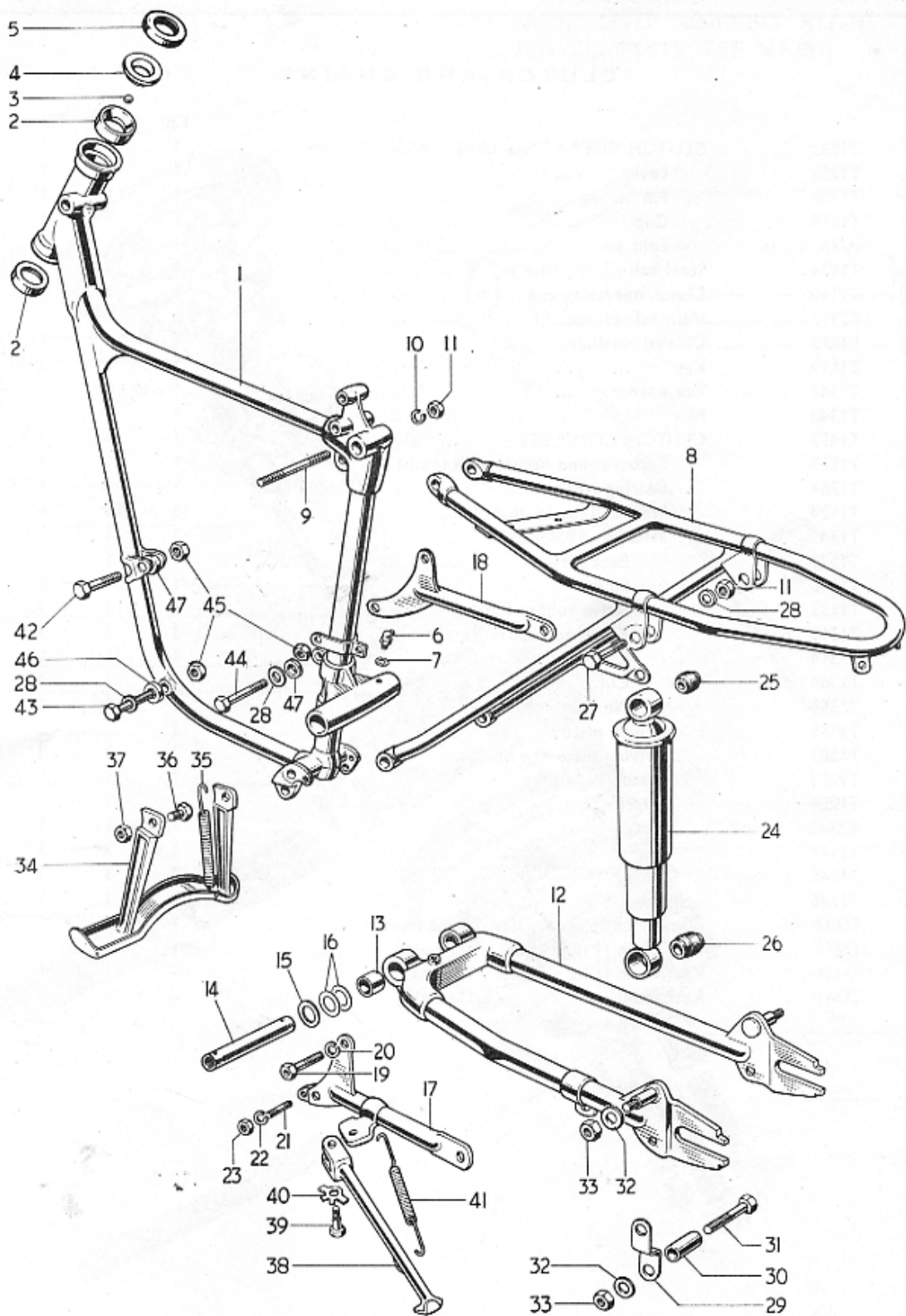

Fig. 8. FRAME COMPLETE

FRAME COMPLETE

			T20	T20S	T20SL	T20T
1	F4594	Front frame	1	1	1	1
2	H835	Steering race cup	2	2	2	2
3	S70-3	Steel ball ($\frac{1}{8}$ in. diam.)	30	30	30	30
4	H833	Top cone	1	1	1	1
5	H836	Dust cover	1	1	1	1
6	KW194	Grease nipple	1	1	1	1
7	WE170	Fibre washer	1	1	1	1
8	F4051	Rear frame	1	-	-	-
8	F4253	Rear frame	-	1	1	1
9	F4510	Stud ($4\frac{3}{8}$ in. O.A.)	1	-	-	-
9	E1023	Stud ($3\frac{3}{8}$ in. O.A.)	-	1	1	1
10	S26-1	Spring washer	2	2	2	2
11	P0172A	Nut	4	4	4	4
12	F4598	SWINGING FORK	1	1	1	1
13	F4076	Pivot bush	2	2	2	2
14	F4079	Spindle	1	1	1	1
15	F4078	Spacing washer	1	1	1	1
16	F4385	Shim, 0.003 in.		as required		
16	F4386	Shim, 0.005 in.		as required		
17	F4080	Left bracket	1	-	-	-
17	F4298	Left bracket	-	1	1	1
18	F4081	Right bracket	1	1	1	1
19	F4509	Bolt ($1\frac{1}{2}$ in. U.H.)	2	-	-	-
19	F4087	Bolt ($1\frac{1}{2}$ in. U.H.)	-	2	2	2
20	PCW73A	Spring washer	2	2	2	2
21	E1396	Stud ($1\frac{1}{8}$ in. O.A.)	2	2	2	2
22	S26-3	Spring washer	2	2	2	2
23	S1-51	Nut	2	2	2	2
24	SC3/204	SUSPENSION UNIT	2	2	2	2
25	9054/316A	Bonded bush	2	2	2	2
26	9054/316J	Bonded bush	2	2	2	2
27	F1760	Bolt ($1\frac{1}{8}$ in. U.H.)	2	2	2	2
28	S25-2	Washer	4	4	4	4
29	F4311	Bracket	-	2	2	2
30	F3207	Spacer	-	2	2	2
31	H622	Bolt ($1\frac{1}{2}$ in. U.H.)	-	2	2	2
32	E1330C	Plain washer	2	4	4	4
33	S1-52	Nut	2	4	4	4
34	F3763	Centre stand	1	-	-	-
35	F3747	Return spring	1	-	-	-
36	F3520	Pivot bolt	2	-	-	-
37	H193	Nut	2	-	-	-
38	F4277	PROP STAND COMPLETE	1	1	1	1
39	F3097	Pivot bolt	1	1	1	1
40	F3096	Tab washer	1	1	1	1
41	F2610	Return spring	1	1	1	1
42	F3953	Bolt ($1\frac{3}{32}$ in. U.H.)	1	1	1	1
43	F3191	Bolt ($2\frac{1}{16}$ in. U.H.)	1	1	1	1
44	F1245	Bolt ($1\frac{1}{8}$ in. U.H.)	1	1	1	1
45	F3955	Self locking nut	3	3	3	3
		Up to Engine Number 57616 use also				
46	F4748	Collar	1	1	1	1
47	F4597	Collar	2	2	2	2

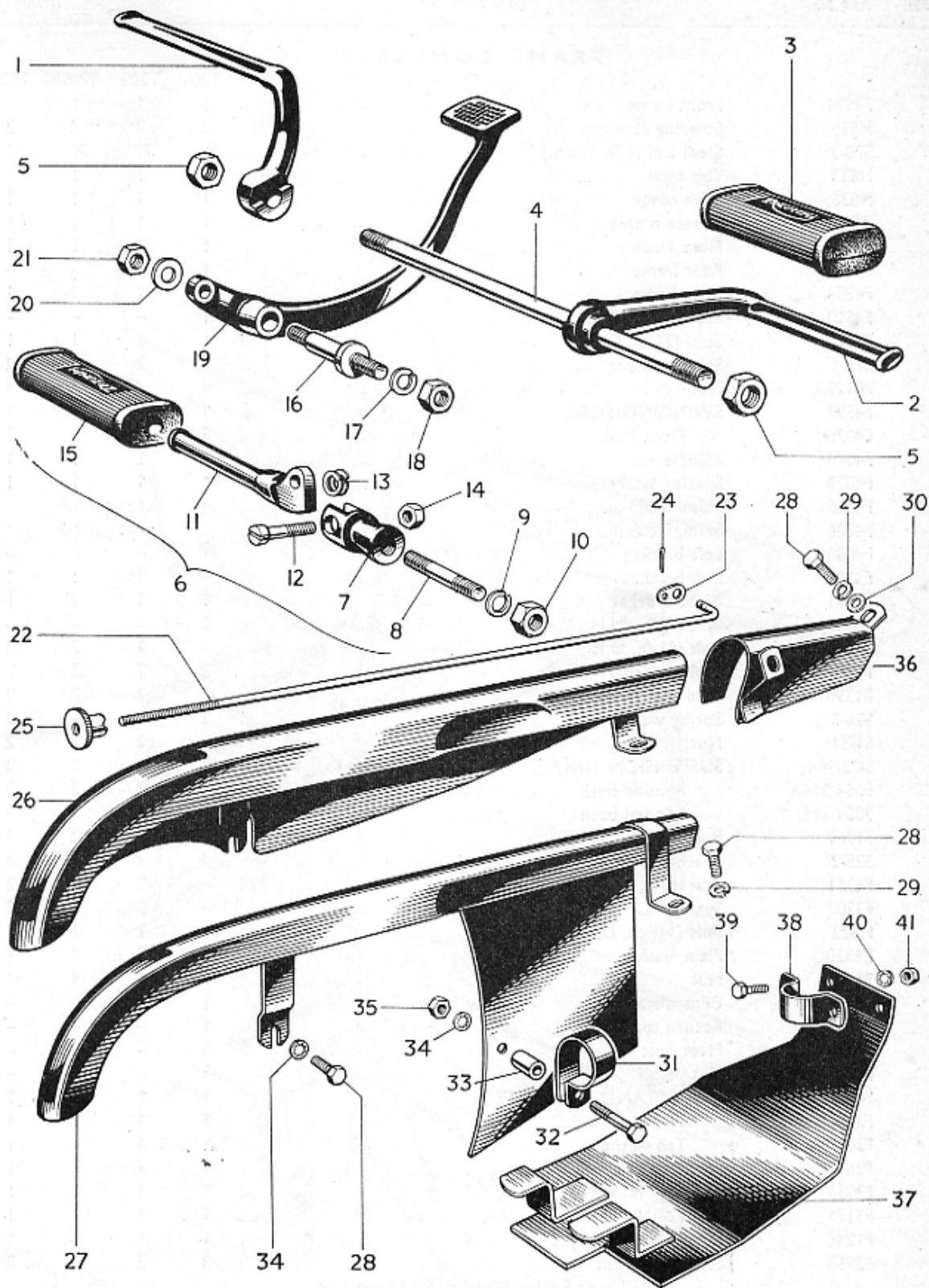

Fig. 9. FOOTRESTS, CHAINGUARD, Etc.

FOOTRESTS, CHAINGUARD, ETC.

									T20	T20S	T20SL	T20T
1	F4383	Left footrest	1	1	1	1
2	F3450	Right footrest	1	1	1	1
3	F1695	Pedal rubber	2	2	2	2
4	F3448	Footrest hanger rod (6 $\frac{1}{4}$ in. O.A.)	1	1	1	1
5	H193	Nut	2	2	2	2
6	F4327	PILLION FOOTREST	2	2	2	2
7	F2268	Footrest hanger	2	2	2	2
8	F4309	Stud (1 $\frac{5}{8}$ in. O.A.)	2	2	2	2
9	S26-1	Spring washer	2	2	2	2
10	P0172A	Nut	2	2	2	2
11	F1694	Pedal	2	2	2	2
12	F2271	Pivot bolt	2	2	2	2
13	F2277	Spring washer	2	2	2	2
14	S1-51	Nut	2	2	2	2
15	F1695	Pedal rubber	2	2	2	2
16	F4090	Brake pedal spindle	1	1	1	1
17	S26-1	Spring washer	1	1	1	1
18	P0172A	Nut	1	1	1	1
19	F4091	Brake pedal	1	1	1	1
20	S25-3	Plain washer	1	1	1	1
21	T224	Nut	1	1	1	1
22	F4093	Brake rod	1	1	1	1
23	F3461	Washer	1	1	1	1
24	$\frac{1}{16}$ in. x $\frac{3}{8}$ in.	Split pin	1	1	1	1
25	F3463	Adjuster nut	1	1	1	1
26	F4089	Rear chainguard	1	-	-	-
27	F4269	Rear chainguard	-	1	1	1
28	DS57	Bolt ($\frac{7}{16}$ in. U.H.)	3	3	3	3
29	S26-2	Spring washer	2	2	2	2
30	S25-1	Plain washer	1	1	1	1
31	F4265	Clip	-	1	1	1
32	E2818	Bolt (1 $\frac{5}{16}$ in. U.H.)	-	1	1	1
33	F4263	Distance piece	-	1	1	1
34	E1612	Serrated washer	-	1	1	1
35	F879	Nut	-	1	1	1
36	F4152	Front chainguard	1	1	1	1
37	F4258	Crankcase shield	-	1	1	1
38	F4260	Clip	-	1	1	1
39	DS57	Bolt ($\frac{7}{16}$ in. U.H.)	-	2	2	2
40	E1612	Serrated washer	-	2	2	2
41	F879	Nut	-	2	2	2

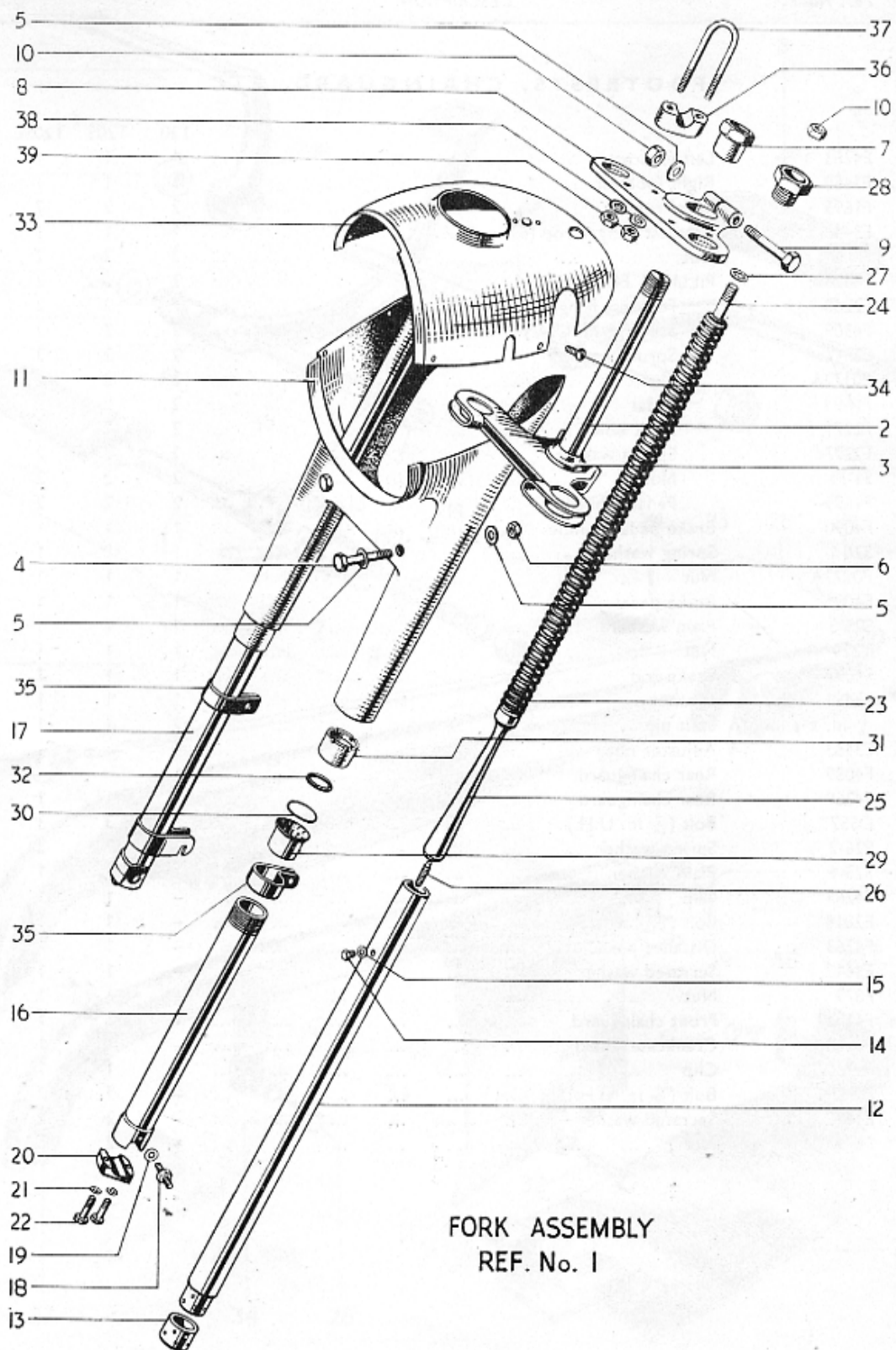

Fig. 10. TELESCOPIC FRONT FORK T20

TELESCOPIC FRONT FORK T20

Ref. No.	Part No.	DESCRIPTION	QUANTITY
			T20
1	H1230	FORK ASSEMBLY	1
2	H1231	Middle lug and stem	1
3	H833	Bottom cone	1
4	H834	Pinch bolt (2 $\frac{3}{8}$ in. U.H.)	2
5	S25-3	Plain washer	5
6	H518	Nut	2
7	H840	Fork stem sleeve nut	1
8	H837	Top lug	1
9	H570	Pinch bolt (2 $\frac{1}{2}$ in. U.H.)	1
10	S1-51	Nut	3
11	H823	Nacelle bottom unit	1
12	H1035	STANCHION C/W BEARING	2
13	H845	Lower bearing	2
14	H519	Oil filler plug ($\frac{1}{8}$ in. U.H.)	2
15	H430	Fibre washer	2
16	H1040	LEFT BOTTOM MEMBER C/W CAP	1
17	H1043	RIGHT BOTTOM MEMBER C/W CAP	1
18	H1042	Oil drain stud ($\frac{3}{32}$ in. O.A.)	2
19	WE170	Fibre washer	2
20	H856	Spindle cap	2
21	E1612	Serrated washer	4
22	W932	Bolt (1 in. U.H.)	4
23	H1037	SPRING ASSEMBLY	2
24	H850	Stud (1 $\frac{9}{16}$ in. O.A.)	2
25	H1047	Restrictor rod	2
26	H1048	Stud (1 $\frac{7}{32}$ in. O.A.)	2
27	E2287	Serrated washer	2
28	H846	Cap nut	2
29	H1046	Top bearing	2
30	H862	Steel washer	2
31	H1045	Dust excluder sleeve nut	2
32	H1044	Oil seal	2
33	H822	Nacelle top	1
34	H916	Screw ($\frac{9}{16}$ in. U.H.)	2
35	H873	Mudguard clip	2
36	H864	Handlebar support	2
37	H865	Handlebar "U" bolt	2
38	S25-13	Plain washer	4
39	F879	Nut	4

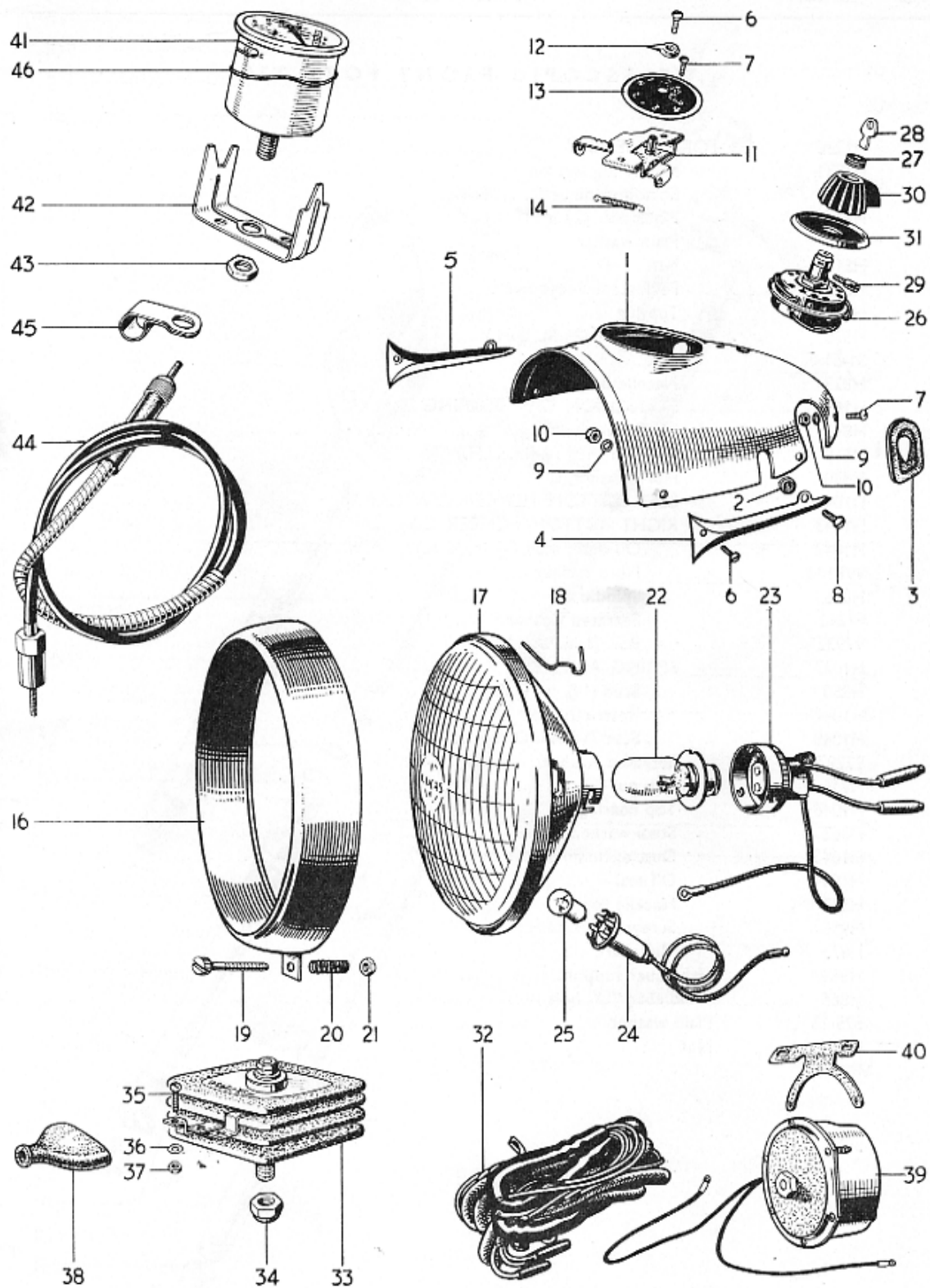

Fig. 11. NACELLE, HEADLAMP, Etc.

NACELLE, HEADLAMP, ETC.

Ref. No.	Part No.	DESCRIPTION	QUANTITY
			T20
1	H822	Nacelle top	1
2	H961	Rubber grommet	3
3	H881	Rubber grommet	2
4	H877	Left motif	1
5	H878	Right motif	1
6	H688	Screw ($\frac{5}{16}$ in. U.H.)	3
7	H689	Screw ($\frac{1}{4}$ in. U.H.)	4
8	H916	Screw ($\frac{9}{32}$ in. U.H.)	2
9	E2880	Serrated washer	4
10	H691	Nut	4
11	H1020	Gear indicator assembly	1
12	H939	Indicator finger	1
13	H921	Indicator plate	1
14	H1019	Return spring	1
15	51519	HEADLAMP ASSEMBLY	1
16	516723	Rim	1
17	516728	Light unit	1
18	500291	Fixing wire	4
19	516710	Screw (H876)	1
20	552373	Spring (H875)	1
21	166014	Nut (H745)	1
22	312	Bulb (30/24 W. Pre-focus, Vertical Dip)	1
23	554946	Adaptor	1
24	554710	Pilot bulbholder	1
25	988	Bulb (3W. M.C.C.)	1
26	31443	LIGHTING AND IGNITION SWITCH P.R.S.8	1
27	318323	Grommet	1
28	318341	Key	1
29	319333	Screw	1
30	318346	Knob	1
31	318343	Index plate	1
32	839101	Wiring harness	1
33	47132	Rectifier	1
34	F3600	Self-locking nut	1
35	F4813	Screw ($\frac{5}{16}$ in. U.H.)	3
36	F4844	Crinkle washer	3
37	H919	Nut	1
38	862566	Grommet	1
39	D300	Horn (Clear Hooters)	1
40	D314	Horn bracket	1
41	SN3153/17	Speedometer, 80 m.p.h.	1
41	SN3153/18	Speedometer, 140 k.p.h.	A
42	31/4/2/1	Fixing strap	1
43	31/1/7	Nut	1
44	D356	Speedometer cable	1
45	F3098	Clip	1
46	W7001	Rubber ring	1

FORK ASSEMBLY
REF. No.1

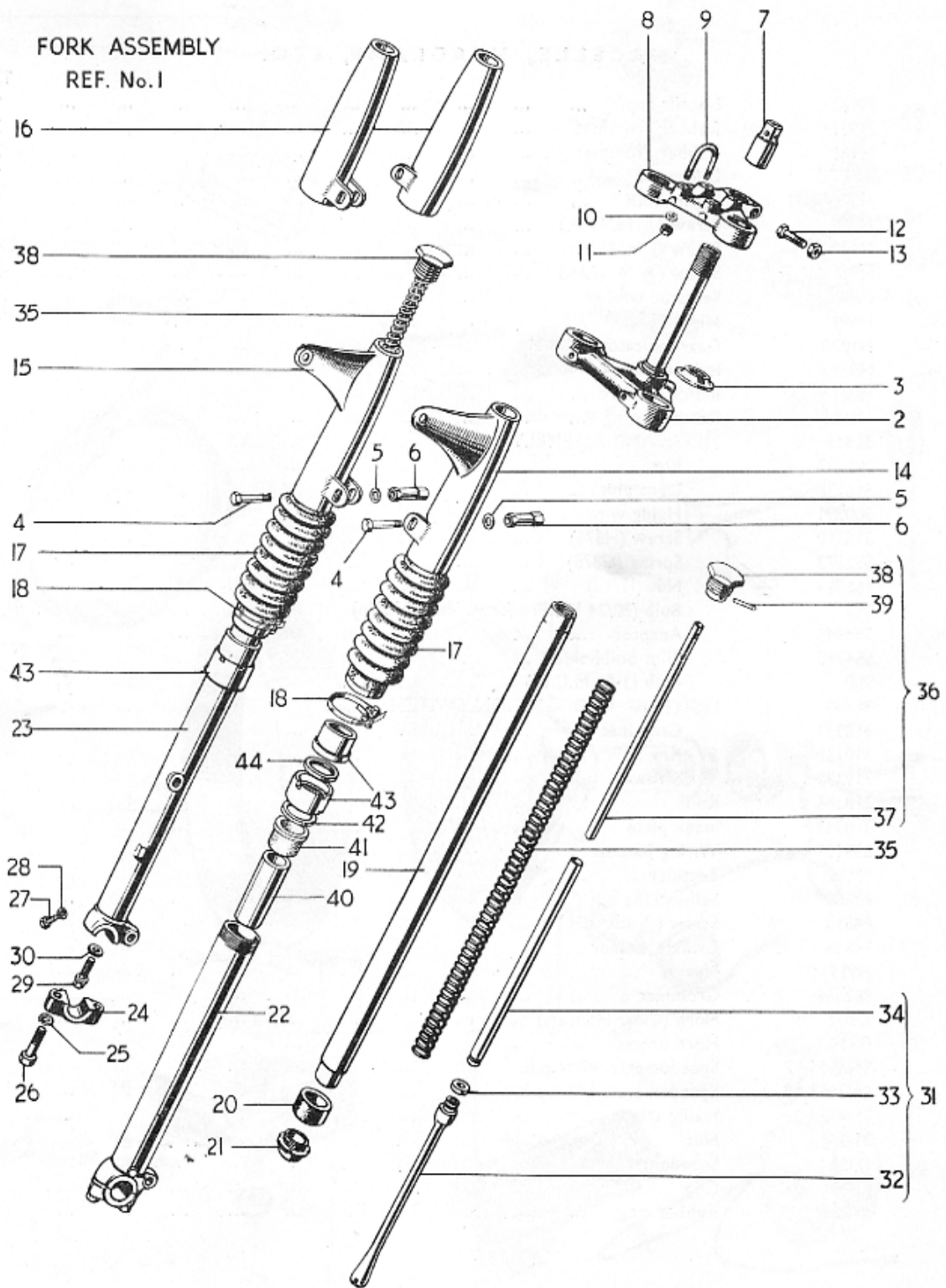

Fig. 12. TELESCOPIC FRONT FORK T20S, T20SL and T20T

TELESCOPIC FORK FRONT T20S, T20SL & T20T

			T20S	T20SL	T20T
1	H1327	FORK ASSEMBLY	1	-	-
1	H1256	FORK ASSEMBLY	-	1	1
2	H1257	Middle lug and stem	1	1	1
3	H833	Bottom cone	1	1	1
4	H941	Pinch bolt (2½ in. U.H.)	2	2	2
5	S25-2	Plain washer	2	2	2
6	H975	Nut	2	2	2
7	H1260	Fork stem sleeve nut	1	1	1
8	H1108	Top lug	1	1	1
9	H660	Handlebar "U" bolt	2	2	2
10	S25-3	Plain washer	4	4	4
11	E1310	Nut	4	4	4
12	F1760	Pinch bolt (1½ in. U.H.)	1	1	1
13	H379	Seated nut	1	1	1
14	H1261	Left top cover	-	1	1
15	H1262	Right top cover	-	1	1
16	H1281	Top cover	2	-	-
17	H962	Telescopic gaiter	2	2	2
18	D340	Gaiter clip	2	2	2
19	H1280	STANCHION C/W BEARING	2	2	2
20	H443	Lower bearing	2	2	2
21	H1058	Bearing nut	2	2	2
22	H1117	LEFT BOTTOM MEMBER C/W CAP	1	1	1
23	H1118	RIGHT BOTTOM MEMBER C/W CAP	1	1	1
24	H1053	Spindle cap	2	2	2
25	S26-3	Spring washer	4	4	4
26	H1070	Bolt (1⅞ in. U.H.)	4	4	4
27	H1071	Drain plug	2	2	2
28	H430	Fibre washer	2	2	2
29	H1063	Flanged bolt (¾ in. U.H.)	2	2	2
30	H1062	Aluminium washer	2	2	2
31	H1124	RESTRICTOR ROD ASSEMBLY	2	2	2
32	H1061	Restrictor rod	2	2	2
33	H1060	Plain washer	2	2	2
34	H1125	Guide tube	2	2	2
35	H1127	Main spring—Yellow	2	2	2
36	H1064A	CAP NUT ASSEMBLY	2	2	2
37	H1051	Guide Tube	2	2	2
38	H1065A	Cap nut	2	2	2
39	H1066	Pin	2	2	2
40	H1126	Damping sleeve	2	2	2
41	H441	Top bearing	2	2	2
42	H431	Plain washer	2	2	2
43	H1194	DUST EXCLUDER SLEEVE NUT	2	2	2
44	H1168	Oil seal	2	2	2



Fig. 13. T20SL HEADLAMP, TACHOMETER, Etc.

T20SL HEADLAMP, TACHOMETER, ETC.

			T20S	T20SL	T20T
1	58395	HEADLAMP	-	1	1
2	534343	Rim	-	1	1
3	54520452	Light unit	-	1	1
4	504665	Fixing wire	-	6	6
5	166	Bulb (24/24 W. Pre-focus, Vertical Dip)	-	1	1
6	554602	Adaptor	-	1	1
7	112201	Bolt	-	2	2
8	137499	Washer	-	2	2
9	31276	Lighting switch	-	1	1
10	31620	Dip switch	-	1	1
11	534296	Screw and plate	-	1	1
12	54094110	Wiring harness	1	-	-
12	54094090	Wiring harness	-	1	1
13	76204	Horn push and cut-out button	1	2	2
14	70145	Horn	-	1	1
15	H1304	Horn bracket	-	1	1
16	H688	Screw ($\frac{5}{16}$ in. U.H.)	-	3	3
17	E2880	Serrated washer	-	3	3
18	H691	Nut	-	3	3
19	SC1102/11	Speedometer 80 m.p.h. ("D" type)	A	1	1
19	SC1102/12	Speedometer 140 k.p.h. ("D" type)	A	A	A
20	N1253	Nut	A	2	2
21	H1264	Speedometer bracket	A	1	1
22	D356	Speedometer cable	A	1	1
23	E4168	COVER WITH TACHOMETER DRIVE	1	A	A
24	E4172	Dowel	2	A	A
25	E2779	Driving gear bush	2	A	A
26	E3686	Driving gear	1	A	A
27	E2749	Driven gear	1	A	A
28	E3682	Bearing housing	1	A	A
29	E3678	Grub screw	1	A	A
30	P21059	End cap (SMITHS)	1	A	A
31	P21060	Jump ring (SMITHS)	1	A	A
32	D441	Tachometer cable	1	A	A
33	H1306	Tachometer top bracket	1	A	A
34	H1087	Rubber bush	2	A	A
35	H1309	Bottom bracket	1	A	A
36	E3801	Screw ($1\frac{1}{8}$ in. U.H.)	2	A	A
37	E1612	Serrated washer	2	A	A
38	F879	Nut	2	A	A
39	RN1102/00	Tachometer 10,000 r.p.m.	1	A	A
40	H1332	Tachometer and speedometer bracket	A	A	A
41	H1334	Bottom bracket	A	A	A
42	SN3172/00	Speedometer 80 m.p.h. (Round type)	A	A	A
43	S26-13	Spring washer	A	A	A
44	31/1/7	Nut	A	A	A

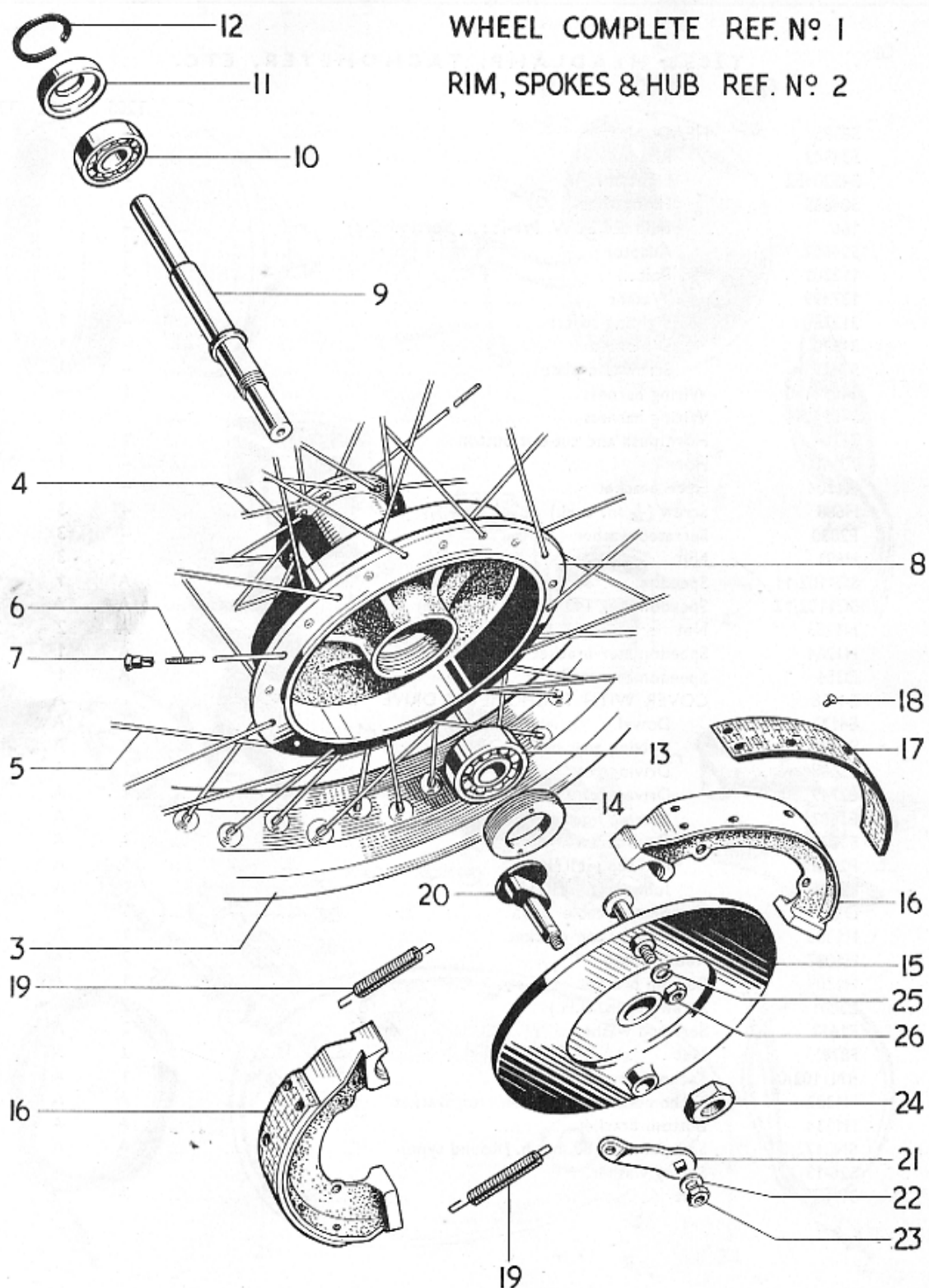

Fig. 14. FRONT WHEEL, T20.

FRONT WHEEL T20

Ref. No.	Part No.	DESCRIPTION	QUANTITY
1	W1379	FRONT WHEEL COMPLETE	1
2	W1380	RIM, SPOKES AND HUB ASSEMBLY	1
3	W1397	Front wheel rim WM2-17	1
4	W1381	Spoke (10/12G x 7 ⁷ / ₁₆ in. 90°) c/w nipple	20
5	W1382	Spoke (10/12G x 5 ⁷ / ₈ in. 100°) c/w nipple	10
6	W1383	Spoke (10/12G x 5 ⁷ / ₈ in. 80°) c/w nipple	10
7	W965	Nipple	40
8	W1286	Hub and brake drum	1
9	W967	Wheel spindle	1
10	T530	Left bearing	1
11	W966	Dust cover	1
12	T532	Circlip	1
13	H826	Right bearing	1
14	W968	Retaining ring	1
15	W1065	Brake anchor plate	1
16	W977	BRAKE SHOE C/W LINING	2
17	W978	Brake lining	2
18	W979	Brass rivet	12
19	W200	Shoe return spring	2
20	W1128	Brake cam	1
21	W1133	Brake cam lever	1
22	S25-71	Plain washer	1
23	T224	Nut	1
24	W1093	Anchor plate nut	1
25	S26-1	Spring washer	1
26	S1-52	Nut	1

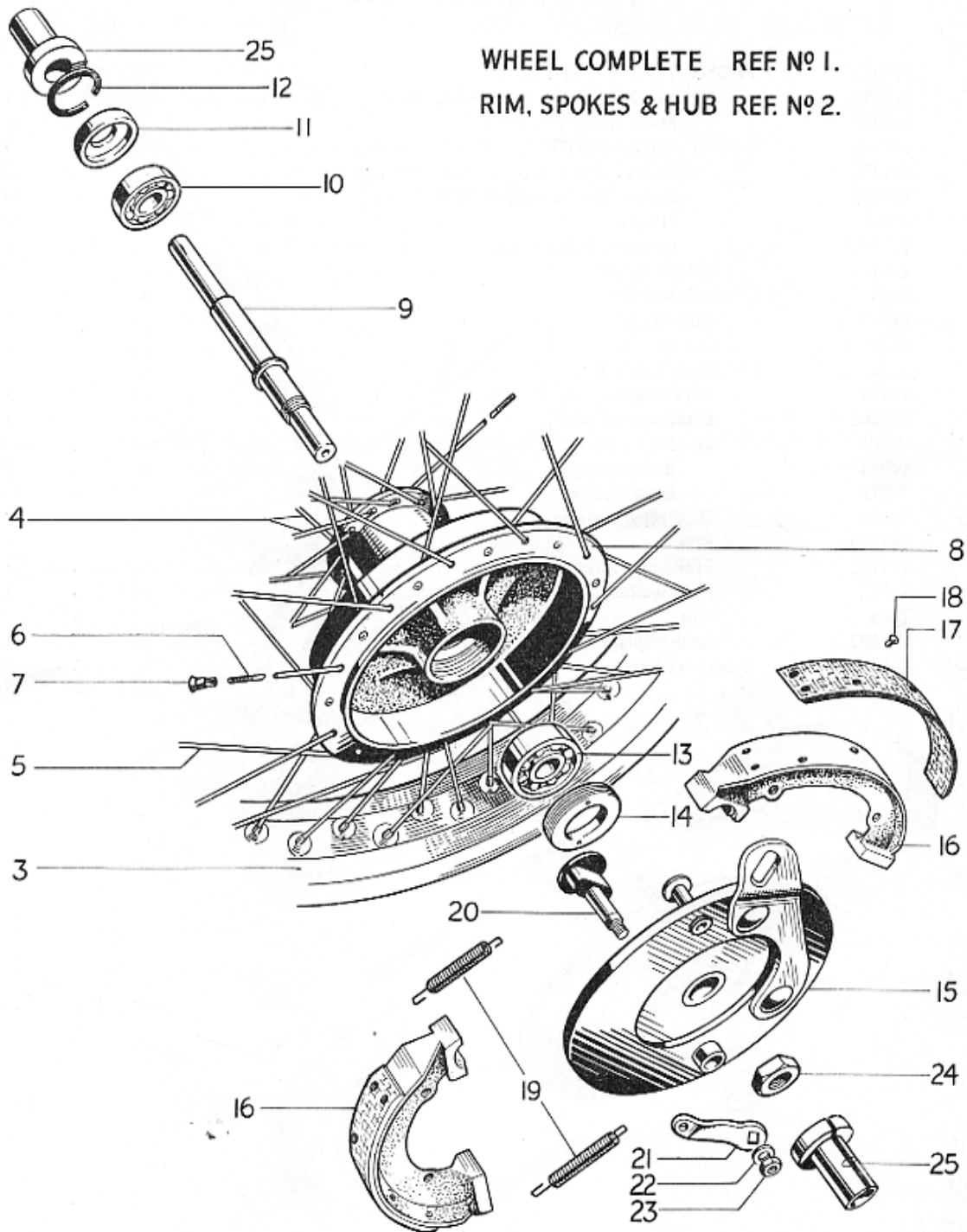
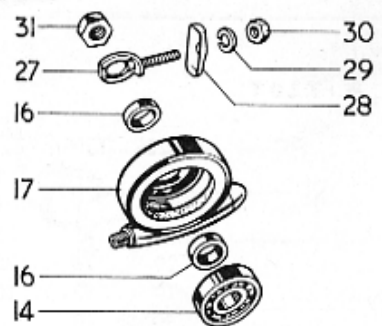

Fig. 15. FRONT WHEEL, T20S, T20SL & T20T.

FRONT WHEEL T20S, T20SL, & T20T

							T20S	T20SL	T20T
1	W1349	FRONT WHEEL COMPLETE	1	1	1
2	W1285	RIM, SPOKES AND HUB ASSEMBLY	1	1	1
3	W1002	Front wheel rim, WM1-19	1	1	1
4	W1289	Spoke (10/12G x 8 $\frac{1}{2}$ in. 90°) c/w nipple	20	20	20
5	W1205	Spoke (10/12G x 6 $\frac{3}{8}$ in. 100°) c/w nipple	10	10	10
6	W1206	Spoke (10/12G x 6 $\frac{3}{8}$ in. 80°) c/w nipple	10	10	10
7	W965	Nipple	40	40	40
8	W1286	Hub and brake drum	1	1	1
9	W1350	Wheel spindle	1	1	1
10	T530	Left bearing	1	1	1
11	W968	Dust cover	1	1	1
12	T532	Circlip	1	1	1
13	H826	Right bearing	1	1	1
14	W968	Retaining ring	1	1	1
15	W1353	Brake anchor plate	1	1	1
16	W977	BRAKE SHOE C/W LINING	2	2	2
17	W978	Brake lining	2	2	2
18	W979	Brass rivet	12	12	12
19	W200	Shoe return spring	1	1	1
20	W1128	Brake cam	1	1	1
21	W1133	Brake cam lever	1	1	1
22	S25-71	Plain washer	1	1	1
23	T224	Nut	1	1	1
24	W1093	Anchor plate nut	1	1	1
25	W1351	Spindle sleeve	2	2	2



WHEEL COMPLETE REF. N° 1
RIM, SPOKES & HUB REF. N° 2

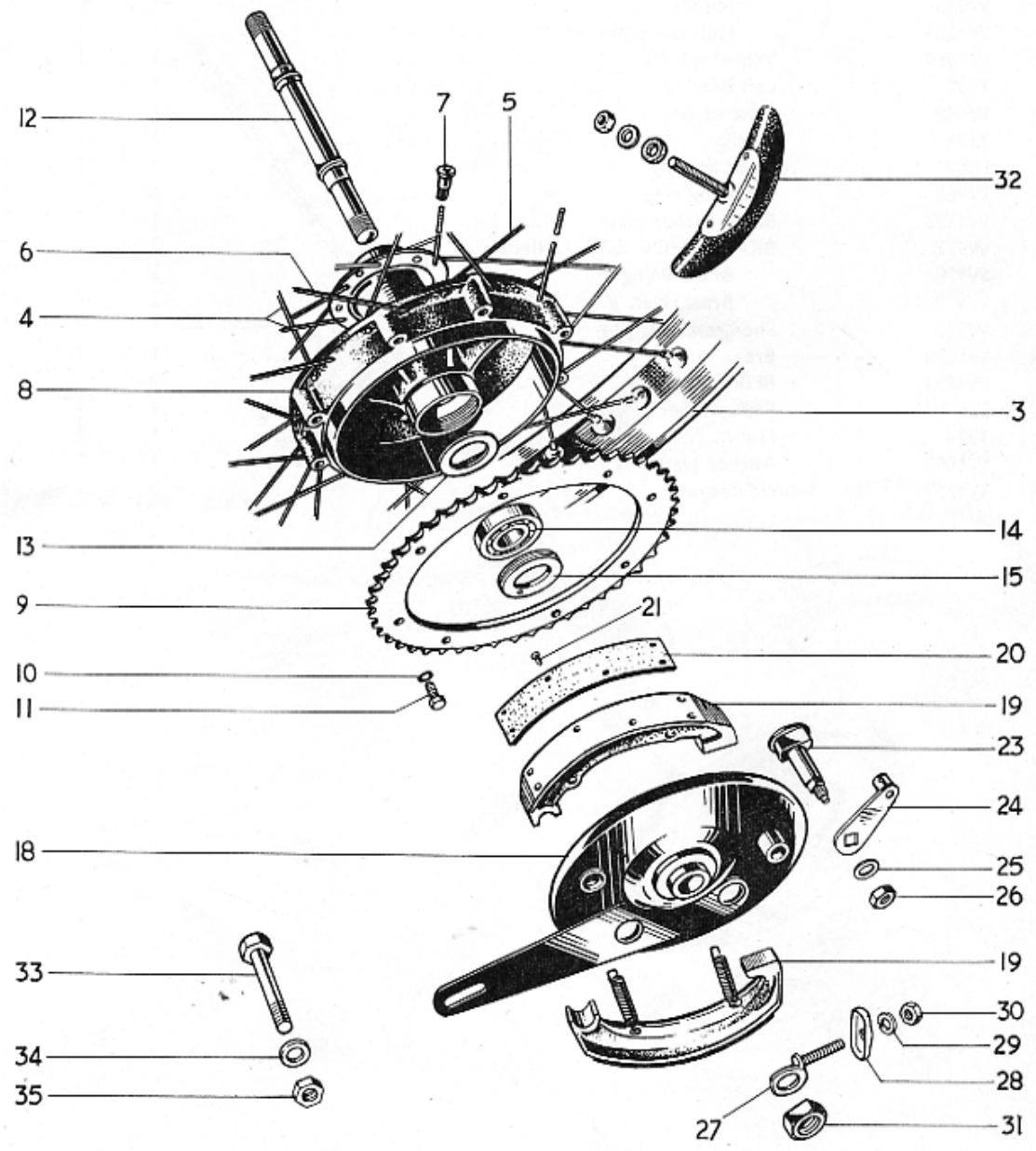

Fig. 16. REAR WHEEL.

REAR WHEEL

						T20	T20S	T20SL	T20T
1	W1384	REAR WHEEL COMPLETE	1	-	-	-
1	W1418	REAR WHEEL COMPLETE	-	1	1	-
1	W1367	REAR WHEEL COMPLETE	-	-	-	1
2	W1385	RIM, SPOKES AND HUB ASSEMBLY	1	-	-	-
2	W1368	RIM, SPOKES AND HUB ASSEMBLY	-	1	1	1
3	W1397	Rear wheel rim WM2-17	1	-	-	-
3	W1296	Rear wheel rim WM2-18	-	1	1	1
4	W1381	Spoke (10/12G x 7 $\frac{7}{16}$ in. 90°) c/w nipple	20	-	-	-
4	W1293	Spoke (10/12G x 7 $\frac{15}{16}$ in. 90°) c/w nipple	-	20	20	20
5	W1382	Spoke (10/12G x 5 $\frac{7}{8}$ in. 100°)	10	-	-	-
5	W1294	Spoke (10/12G x 6 $\frac{3}{8}$ in. 100°)	-	10	10	10
6	W1383	Spoke (10/12G x 5 $\frac{3}{8}$ in. 80°)	10	-	-	-
6	W1295	Spoke (10/12G x 6 $\frac{3}{8}$ in. 80°)	-	10	10	10
7	W965	Nipple	40	40	40	40
8	W1362	Hub and brake drum	1	1	1	1
9	W1320	Sprocket (46T)	1	-	-	-
9	W984	Sprocket (48T)	-	1	1	-
9	W1076	Sprocket (54T)	-	-	-	1
10	W1122	Spring washer	8	8	8	8
11	W1322	Bolt ($\frac{5}{8}$ in. U.H.)	8	8	8	8
12	W989	Spindle	1	1	1	1
13	W987	Backing ring	1	1	1	1
14	H826	Bearing	2	2	2	2
15	W988	Retaining ring	1	1	1	1
16	W1223	Distance piece	2	2	2	2
17	D175	Speedometer gearbox	1	1	1	1
18	W1365	Brake anchor plate	1	1	1	1
19	W977	BRAKE SHOE C/W LINING	2	2	2	2
20	W978	Brake lining	2	2	2	2
21	W979	Brass rivet	12	12	12	12
22	W200	Shoe return spring	2	2	2	2
23	W1128	Brake cam	1	1	1	1
24	W1221	Brake cam lever	1	1	1	1
25	S25-71	Plain washer	1	1	1	1
26	T224	Nut	1	1	1	1
27	W1224	Chain adjuster	2	2	2	2
28	W1227	End plate	2	2	2	2
29	S26-2	Spring washer	2	2	2	2
30	F879	Nut	2	2	2	2
31	W1000	Nut	2	2	2	2
32	D106	Tyre security bolt	-	1	1	1
33	H211	Bolt ($\frac{1}{2}$ in. U.H.)	1	1	1	1
34	F2184	Plain washer	1	1	1	1
35	F3955	Self-locking nut	1	1	1	1

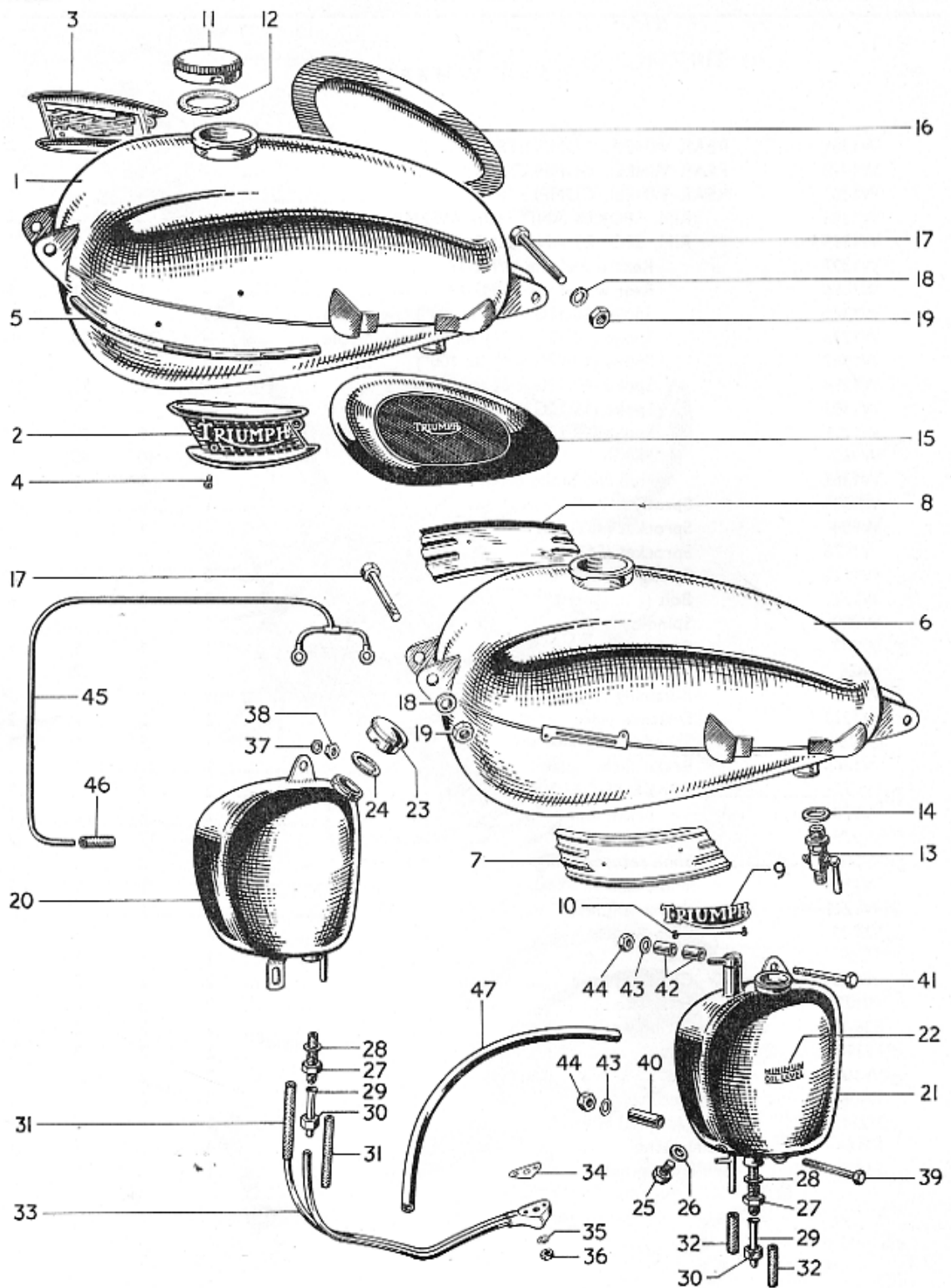

Fig. 17. PETROL AND OIL TANKS.

PETROL AND OIL TANKS

								T20	T20S	T20SL	T20T
1	F4496	Petrol tank	1	-	-	-
2	F4570	Left styling unit	1	-	-	-
3	F4571	Right styling unit	1	-	-	-
4	F4468	Screw ($\frac{9}{16}$ in. U.H.)	4	-	-	-
5	F4902	Styling strip	2	-	-	-
6	F3505	Petrol tank	-	1	1	1
7	F3494	Left styling band	-	1	1	1
8	F3495	Right styling band	-	1	1	1
9	F3496	Nameplate	-	2	2	2
10	F3497	Screw ($\frac{13}{16}$ in. U.H.)	-	4	4	4
11	F3220	FILLER CAP	1	1	1	1
12	F4048	Joint washer	1	1	1	1
13	F3506	Petrol tap	1	1	1	1
14	E697	Fibre washer	1	1	1	1
15	F1606	Left knee grip	1	1	1	1
16	F1605	Right knee grip	1	1	1	1
17	F3498	Bolt ($2\frac{3}{8}$ in. U.H.)	2	2	2	2
18	S25-3	Plain washer	3	3	3	3
19	S1-51	Nut	2	2	2	2
20	F4490	OIL TANK	1	-	-	-
21	F4318	OIL TANK	-	1	1	1
22	A3	Transfer (Minimum oil level)	1	1	1	1
23	F3216	FILLER CAP	1	1	1	1
24	F4047	Joint washer	1	1	1	1
25	F1792	Drain plug	-	1	1	1
26	PT104B	Fibre washer	-	1	1	1
27	F3876	Filter	1	1	1	1
28	F1511	Fibre washer	1	1	1	1
29	F3503	Upper feed pipe	1	1	1	1
30	F3504	Union nut	1	1	1	1
31	F4530	Rubber connector	2	-	-	-
32	F3077	Rubber connector	-	2	2	2
33	E3270	Oil pipes and junction block	1	1	1	1
34	E3274	Joint washer	1	1	1	1
35	S25-13	Plain washer	1	1	1	1
36	F879	Nut	1	1	1	1
37	S25-2	Plain washer	1	-	-	-
38	S1-52	Nut	1	-	-	-
39	F2596	Bolt ($1\frac{1}{4}$ in. U.H.)	-	1	1	1
40	F3477	Distance piece	-	1	1	1
41	F3468	Bolt ($2\frac{1}{16}$ in. U.H.)	-	1	1	1
42	F3476	Distance piece	-	2	2	2
43	S25-3	Plain washer	-	2	2	2
44	S1-51	Nut	-	2	2	2
45	E3244	Rocker oil feed pipe	1	1	1	1
46	E3383	Rubber connector	1	1	1	1
47	T1203	Flexible vent pipe	1	1	1	1

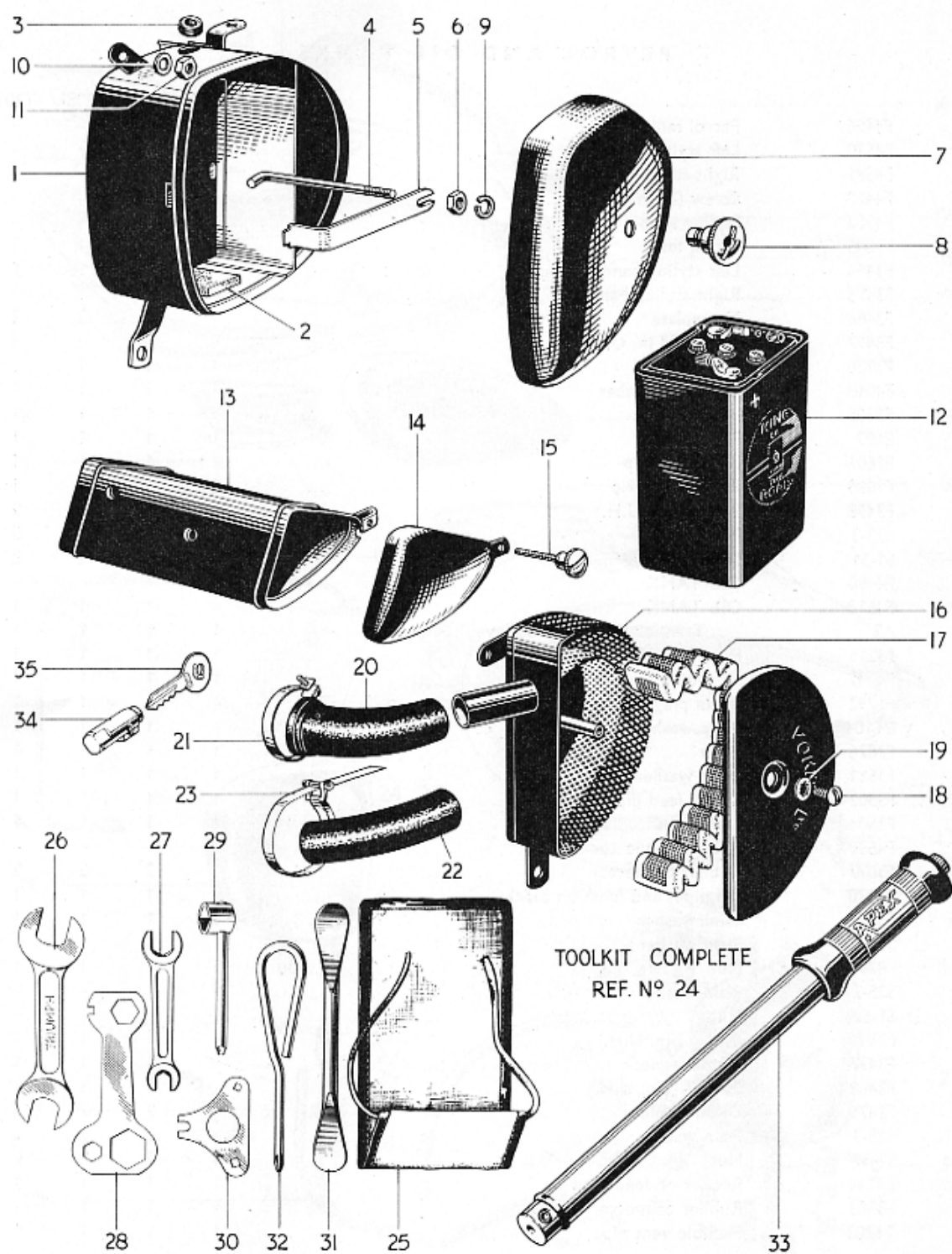

Fig. 18. BATTERY CASE, TOOLBOX AND AIR FILTER.

BATTERY CASE, TOOLBOX AND AIR FILTER

							T20	T20S	T20SL	T20T
1	F4515	BATTERY CASE AND TOOLBOX	1	-	-	-
2	F3470	Rubber pad	1	-	-	-
3	199002	Grommet	1	-	-	-
4	F3472	Hook bolt	1	-	-	-
5	F3473	Strap	1	-	-	-
6	F879	Nut	1	-	-	-
7	F3493	LID C/W KNOB	1	-	-	-
8	F3474	Knob	1	-	-	-
9	F3475	Clirclip	1	-	-	-
10	S25-2	Plain washer	1	-	-	-
11	S1-52	Nut	1	-	-	-
12	408200	Battery PUZSE/11	1	-	-	-
13	F4877	TOOLBOX	-	1	1	1
14	F4882	Toolbox lid	-	1	1	1
15	F4885	Fastener screw	-	1	1	1
16	F4550	AIR FILTER	-	1	1	1
17	F3315E	Element only	-	1	1	1
18	F3376	Screw ($\frac{3}{8}$ in. U.H.)	-	1	1	1
19	E1612	Serrated washer	-	1	1	1
20	E4214	Rubber connector	-	1	1	-
21	F3859	Clip	-	1	1	-
22	F4592	Rubber connector	-	-	-	1
23	D404	Clip	-	-	-	1
24	D290	TOOLKIT	1	1	1	1
25	D291	Toolbag	1	1	1	1
26	D299	Open spanner, $\frac{3}{8}$ in. x $\frac{7}{16}$ in. Whit.	1	1	1	1
27	D292	Open spanner, $\frac{1}{8}$ in. x $\frac{3}{16}$ in. x $\frac{1}{4}$ in. x $\frac{5}{16}$ in. Whit.	1	1	1	1
28	D293	Combination spanner, $\frac{3}{16}$ in. x $\frac{5}{16}$ in. x $\frac{1}{2}$ in. Whit.	1	1	1	1
29	D294	Screwdriver and $\frac{1}{4}$ in. Whit. spanner	1	1	1	1
30	DA70	Clutch key	1	1	1	1
31	NA14A	Tyre lever	1	1	1	1
32	D335	Phillips No. 2 screwdriver	1	1	1	1
33	D296	Tyre inflator	1	1	1	1
34	D402/3	FRAME LOCK C/W KEYS	1	1	1	1
35	D403	Key (state number)	1	1	1	1

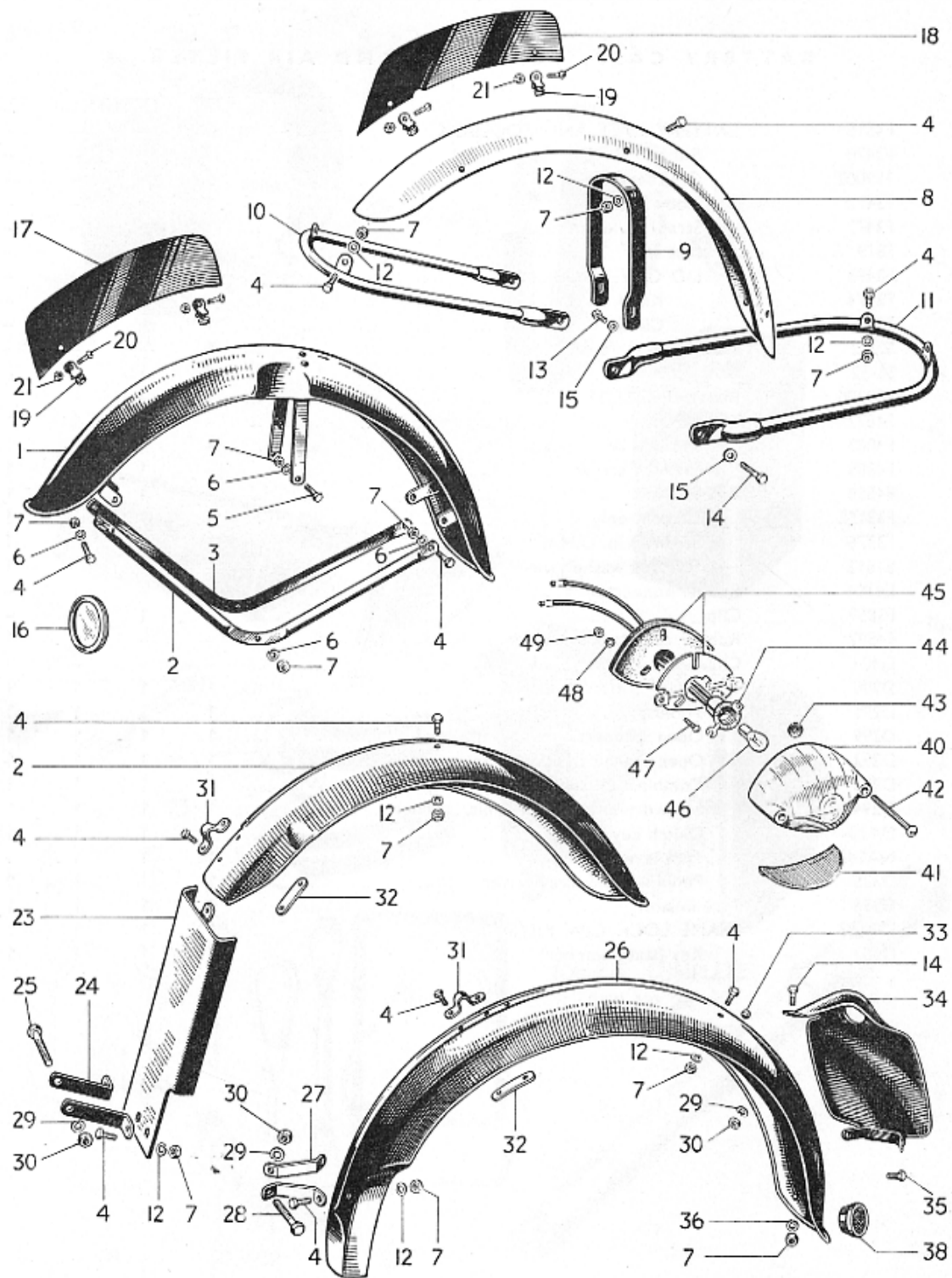

Fig. 19. MUDGUARDS AND NUMBER PLATES.

MUDGUARDS AND NUMBER PLATES

								T20	T20S	T20SL	T20T
1	H929	Front mudguard	1	-	-	-
2	H871	Left stay	1	-	-	-
3	H872	Right stay	1	-	-	-
4	DS57	Bolt ($\frac{7}{16}$ in. U.H.)	10	12	12	12
5	GS218	Bolt ($\frac{9}{16}$ in. U.H.)	2	-	-	-
6	E1612	Serrated washer	8	-	-	-
7	F879	Nut	14	12	12	12
8	H1269	Mudguard blade	-	1	1	1
9	H1270	Bridge	-	1	1	1
10	H1271	Front stay	-	1	1	1
11	H1273	Lower stay	-	1	1	1
12	S25-1	Plain washer	6	12	12	12
13	F2335	Bolt ($\frac{11}{16}$ in. U.H.)	-	2	2	2
14	F929	Bolt ($\frac{1}{2}$ in. U.H.)	1	3	3	3
15	S25-3	Plain washer	-	4	4	4
16	D261	Licence holder	1	-	1	1
17	H874	Number plate	1	-	-	-
18	F2996	Number plate	-	-	1	1
19	H741	Clip assembly	2	-	2	2
20	H687	Screw ($\frac{3}{8}$ in. U.H.)	2	-	2	2
21	H745	Nut	2	-	2	2
22	F4497	Mudguard	1	-	-	-
23	F4499	Mudshield	1	-	-	-
24	F4502	Stay	2	-	-	-
25	F4531	Bolt ($1\frac{1}{8}$ in. U.H.)	1	-	-	-
26	F4604	Mudguard	-	1	1	1
27	F4606	Stay	-	2	2	2
28	DS55	Bolt ($\frac{13}{16}$ in. U.H.)	-	1	1	1
29	S26-3	Spring washer	2	2	2	2
30	S1-51	Nut	2	2	2	2
31	PF204	Clip	1	1	1	1
32	F444	Backing plate	1	1	1	1
33	E3203	Grommet	2	2	2	2
34	F3508	Number plate	1	-	1	1
35	F1369	Bolt ($\frac{5}{8}$ in. U.H.)	2	-	2	2
36	S26-2	Spring washer	2	-	2	2
37	D68	Transfer "Triumph"	1	-	1	1
38	57080	Reflector	1	-	1	1
39	53256	Tail lamp (Type 529)	1	-	-	-
39	53331	Stop and tail lamp (Type 529)	A	-	1	1
40	526404	Lens	1	-	1	1
41	526406	Window	1	-	1	1
42	133551	Screw	2	-	2	2
43	161020	Washer	2	-	2	2
44	554719	Bulb holder	1	-	-	-
44	526418	Bulb holder	-	-	1	1
45	526408	Base	1	-	-	-
45	526415	Base	-	-	1	1
46	988	Bulb 3W. M.C.C.	1	-	-	-
46	352	Bulb 3/18W. Offset pin	-	-	1	1
47	526410	Screw	2	-	2	2
48	166103	Nut	2	-	2	2
49	188412	Washer	2	-	2	2

TWINSEAT ASSY. REF. N° 1

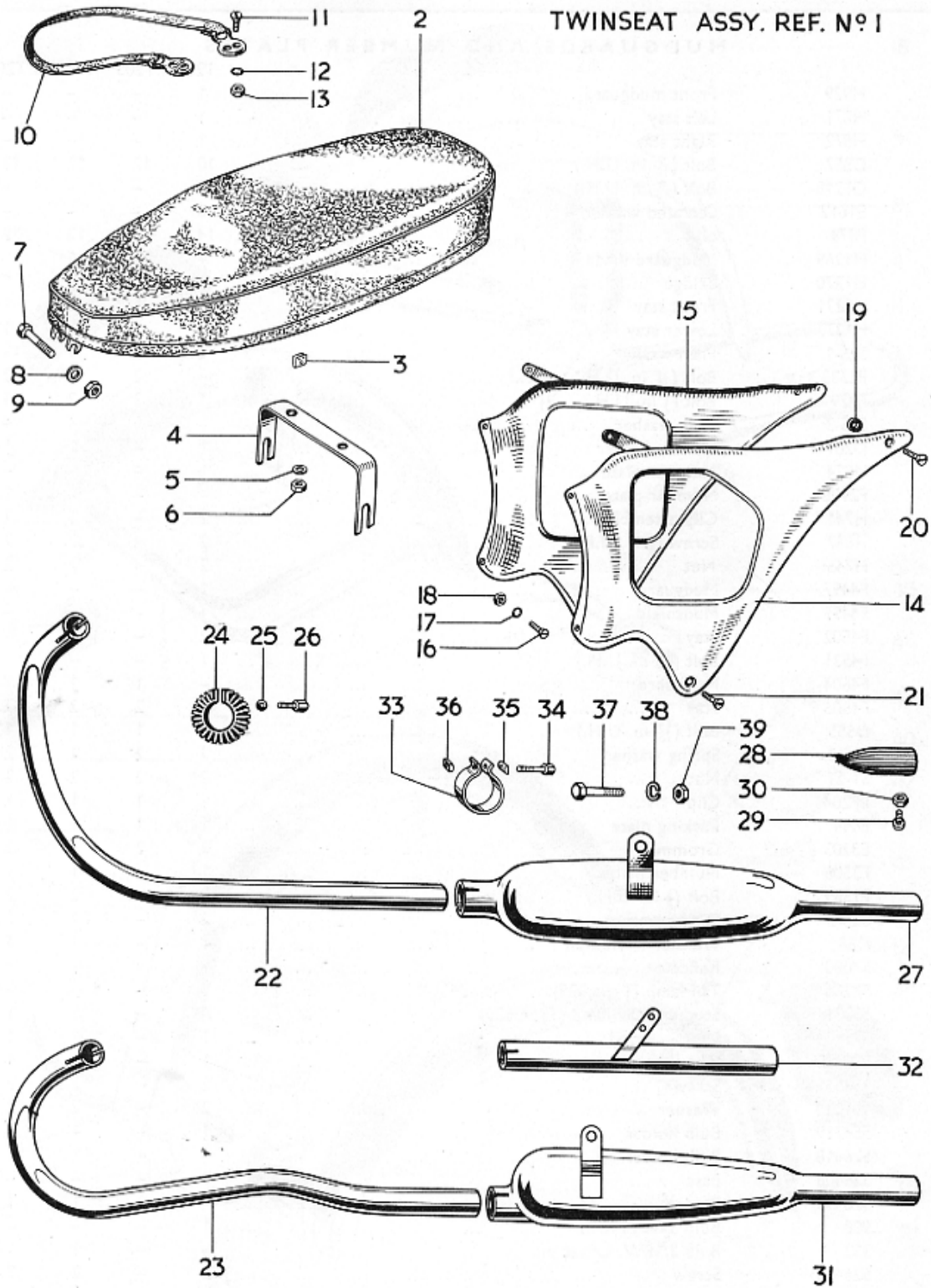

Fig. 20. TWINSEAT, REAR PANELS AND EXHAUST SYSTEM.

TWINSEAT, REAR PANELS AND EXHAUST SYSTEM

									T20	T20S	T20SL	T20T
1	F4516	TWINSEAT	1	-	-	-
1	F4272	TWINSEAT	-	1	1	1
2	F4104	Cover c/w Clips	1	1	1	1
3	F4475	Clip		as required		
4	F4105	Rear bracket	1	-	-	-
4	F4261	Rear bracket	-	1	1	1
5	E1612	Serrated washer	2	2	2	2
6	F879	Nut	2	2	2	2
7	E3181	Bolt (2½ in. U.H.)	1	-	-	-
7	E667A	Bolt (1½ in. U.H.)	-	1	1	1
8	S25-3	Plain washer	1	1	1	1
9	S1-51	Nut	1	1	1	1
10	F4361	Safety strap	A	A	A	A
11	F4129	Screw (½ in. U.H.)	4	4	4	4
12	GS299	Serrated washer	4	4	4	4
13	H745	Nut	4	4	4	4
14	F4503	Left panel	1	-	-	-
15	F4505	Right panel	1	-	-	-
16	H687	Screw (⅜ in. U.H.)	2	-	-	-
17	E2351	Serrated washer	2	-	-	-
18	F3799	Nut	2	-	-	-
19	F4512	Rubber washer	2	-	-	-
20	F4483	Self-tapping screw	2	-	-	-
21	F4511	Screw (⅜ in. U.H.)	2	-	-	-
22	E3257	Exhaust pipe	1	-	-	-
23	E3883	Exhaust pipe	-	1	1	1
23	E4173	Exhaust pipe (with tachometer, see page 43)	-	A	A	-
24	E3259	Clip	1	1	1	1
25	S25-13	Plain washer	1	1	1	1
26	E3260	Bolt (⅞ in. U.H.)	1	1	1	1
27	E3928	Silencer	1	-	-	-
28	E4076	Silencer mute	1	-	-	-
29	H689	Screw (¼ in. U.H.)	1	-	-	-
30	H691	Nut	1	-	-	-
31	E3840	Silencer	-	-	1	1
32	E3967	Extension pipe	A	1	A	A
33	E3269	Clip	1	1	1	1
34	TE164E	Bolt	1	1	1	1
35	TE164D	"D" washer	1	1	1	1
36	TE164C	"D" nut	1	1	1	1
37	F929	Bolt (½ in. U.H.)	-	1	1	1
38	S26-1	Spring washer	-	1	1	1
39	P0172A	Nut	-	1	1	1

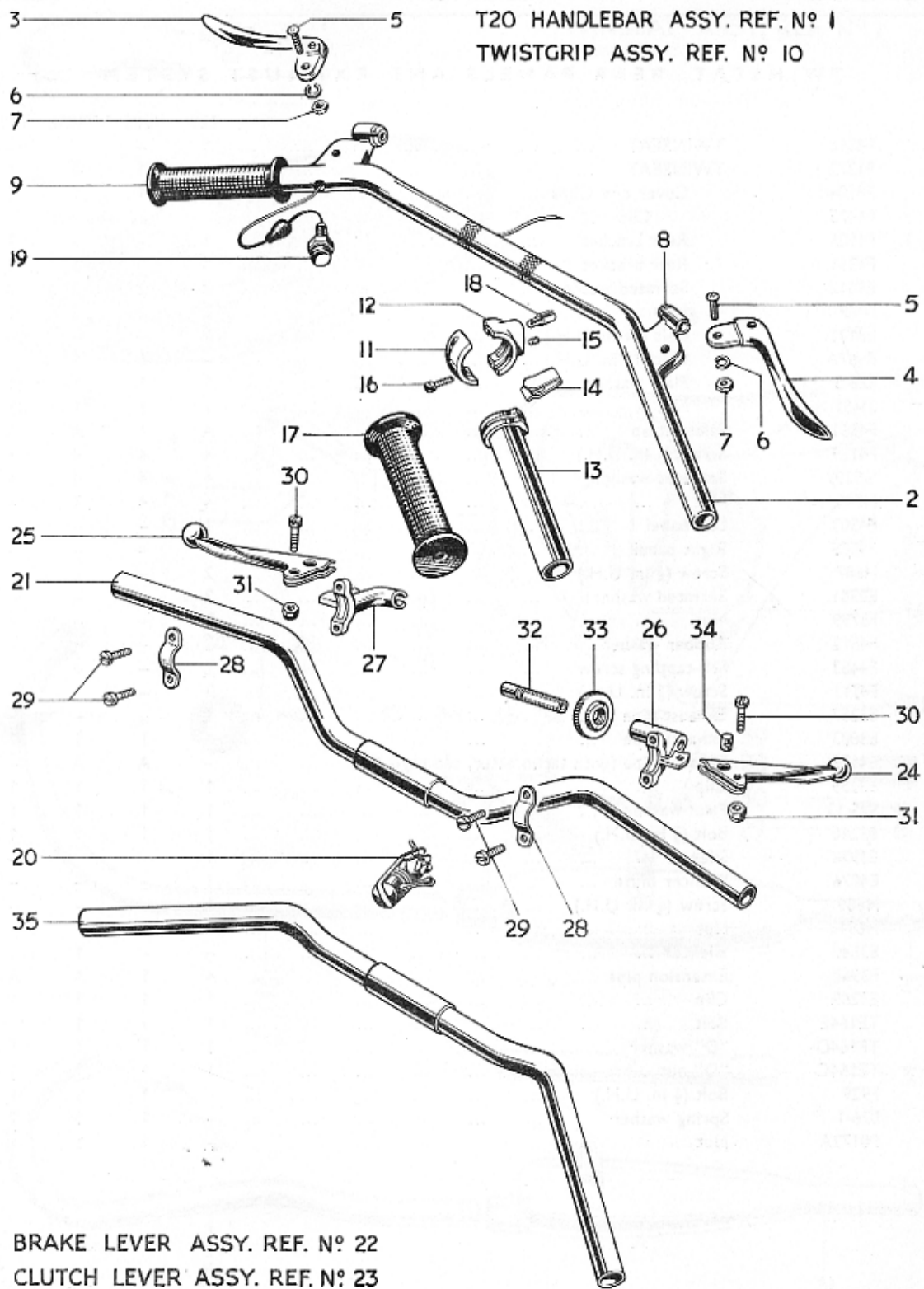

Fig. 21. HANDLEBARS AND CONTROL LEVERS.

HANDLEBARS AND CONTROL LEVERS

							T20	T20S	T20SL	T20T
1	70/510	HANDLEBAR C/W CONTROLS	1	-	-	-
2	91/322	Handlebar c/w lever brackets	1	-	-	-
3	70/316	Clutch lever	1	-	-	-
4	70/317	Front brake lever	1	-	-	-
5	100/006	Screw	2	-	-	-
6	70/016	Spring washer	2	-	-	-
7	18/717	Nut	2	-	-	-
8	70/005	Cable stop	2	-	-	-
9	16/069	Handlebar grip	1	-	-	-
10	366/2	TWISTGRIP	1	1	1	1
11	366/001	Body top half	1	1	1	1
12	366/002	Body bottom half	1	1	1	1
13	366/004	Rotor	1	1	1	1
14	366/007	Friction spring	1	1	1	1
15	366/008	Friction spring screw	1	1	1	1
16	376/079	Screw	2	2	2	2
17	16/070	Handlebar grip	1	1	1	1
18	366/006	Cable stop	1	1	1	1
19	H886	Horn push	1	-	-	-
20	31482	Dipper switch	1	-	-	-
21	H1266	Handlebar bend	-	1	1	1
22	18/935	FRONT BRAKE LEVER ASSEMBLY (Ball-end)	-	1	1	1
23	18/763	CLUTCH LEVER ASSEMBLY (Ball-end)	-	1	1	1
24	18/754	Brake lever (Ball-end)	-	1	1	1
25	18/752	Clutch lever (Ball-end)	-	1	1	1
26	18/912	Brake lever bracket	-	1	1	1
27	18/234	Clutch lever bracket	-	1	1	1
28	12/040	Clamp	-	2	2	2
29	11/014	Screw	-	4	4	4
30	18/087	Fulcrum screw	-	2	2	2
31	18/053	Self-locking nut	-	2	2	2
32	18/838	Cable adjuster	-	1	1	1
33	18/839	Thumb nut	-	1	1	1
34	18/880	Barrel nipple	-	1	1	1
35	H1339	Handlebar bend	-	-	A	-

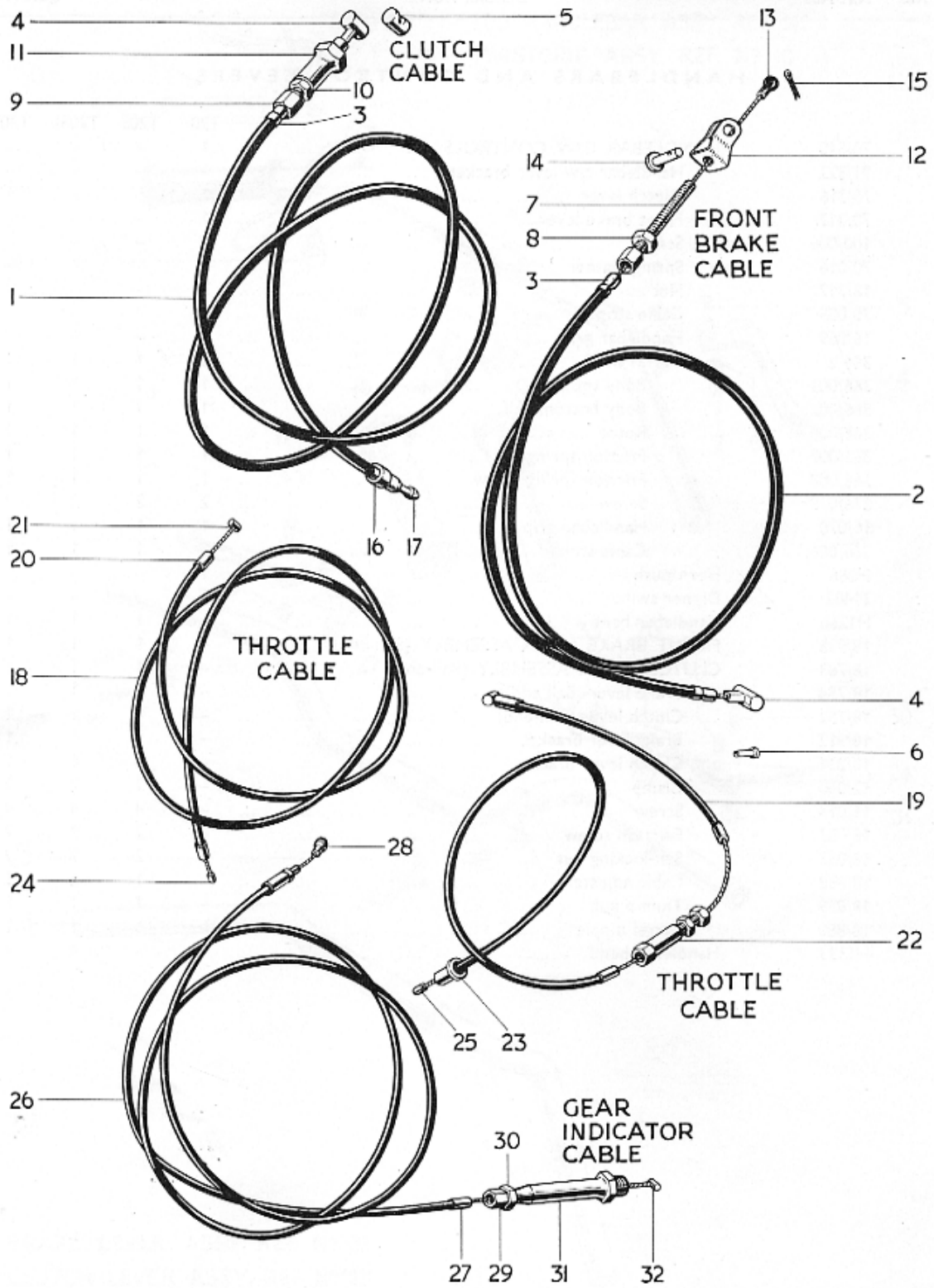

Fig. 22. CONTROL CABLES.

CONTROL CABLES

									T20	T20S	T20SL	T20T
1	D331	CLUTCH CABLE	1	-	-	-
1	D332	CLUTCH CABLE	-	1	1	1
2	D323	FRONT BRAKE CABLE	1	-	-	-
2	D429	FRONT BRAKE CABLE	-	1	1	1
3	D103	Ferrule	4	4	4	4
4	18/706	Nipple	2	-	-	-
5	D81	Nipple	-	1	1	1
6	D368	Nipple	-	1	1	1
7	D279	Cable adjuster	1	-	-	-
8	F879	Nut	1	-	-	-
9	D319	Cable adjuster	1	1	1	1
10	D268	Nut	1	1	1	1
11	D288	Abutment	1	1	1	1
12	D280	Clevis	1	1	1	1
13	DS73	Nipple	1	1	1	1
14	D281	Clevis pin	1	1	1	1
15	$\frac{1}{16}$ in. x $\frac{3}{8}$ in.	Split pin	1	1	1	1
16	D333	Abutment	1	1	1	1
17	D334	Nipple	1	1	1	1
18	D406	THROTTLE CABLE	1	-	-	1
19	D420	THROTTLE CABLE	-	1	1	-
20	12/083	Ferrule	2	3	3	2
21	D411	Nipple	1	1	1	1
22	D104	Adjuster	-	1	1	-
23	6/132A	Ferrule	-	1	1	-
24	D407	Nipple	1	-	-	1
25	NS191	Nipple	-	1	1	-
26	D282	GEAR INDICATOR CABLE	1	-	-	-
27	12/083	Ferrule	2	-	-	-
28	18/115	Nipple	1	-	-	-
29	D284	Adjuster	1	-	-	-
30	H745	Nut	1	-	-	-
31	E3280	Abutment	1	-	-	-
32	D285	Nipple	1	-	-	-

CARBURETTER COMPLETE
REF. No. 1

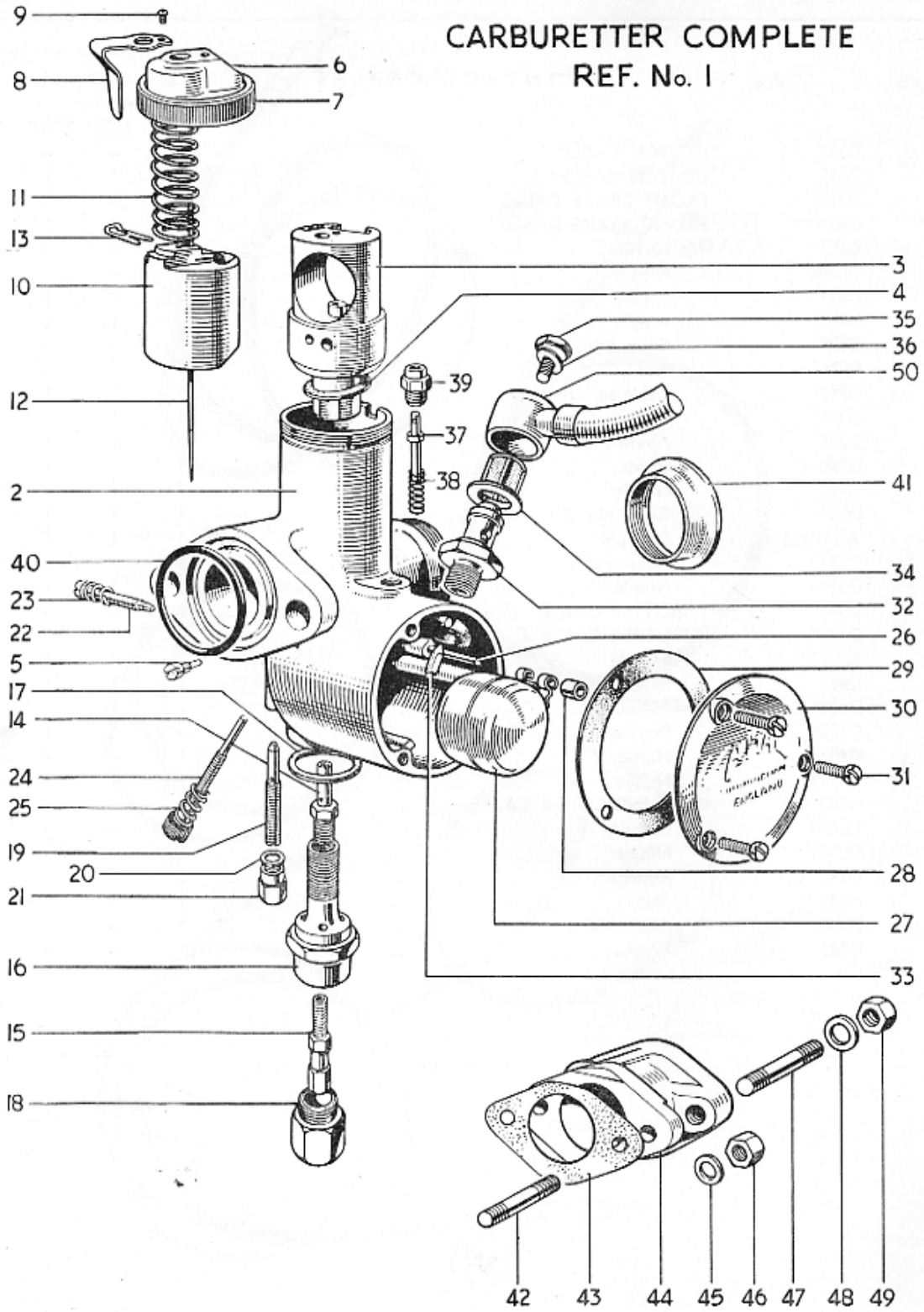

Fig. 23. AMAL CARBURETTER.

AMAL CARBURETTER

								T20	T20S	T20SL	T20T
1	376/272	CARBURETTER COMPLETE...	-	1	1	-
2	376/001	Mixing chamber	-	1	1	-
3	376/055	Jet block	-	1	1	-
4	376/067	Joint washer	-	1	1	-
5	376/070	Peg screw	-	1	1	-
6	376/155	Mixing chamber top	-	1	1	-
7	376/065	Cap ring	-	1	1	-
8	29/308	Spring	-	1	1	-
9	4/241	Screw	-	1	1	-
10	376/060	Throttle valve (3 cutaway)	-	1	1	-
11	376/061	Spring	-	1	1	-
12	376/063	Needle (Type C)	-	1	1	-
13	4/230	Clip	-	1	1	-
14	376/072	Needle jet (106)	-	1	1	-
15	376/100	Main jet (140)	-	1	1	-
16	376/073	Jet holder	-	1	1	-
17	376/074	Fibre washer	-	1	1	-
18	376/075	Cover nut	-	1	1	-
19	376/076	Pilot jet (20)	-	1	1	-
20	116/162	Fibre washer	-	1	1	-
21	376/095	Cover nut	-	1	1	-
22	332/017	Air adjusting screw	-	1	1	-
23	4/148	Spring	-	1	1	-
24	376/068	Throttle stop screw	-	1	1	-
25	376/069	Spring	-	1	1	-
26	376/085	Float spindle	-	1	1	-
27	376/083	Float	-	1	1	-
28	376/094	Bush	-	1	1	-
29	376/078	Joint washer	-	1	1	-
30	376/077	Cover	-	1	1	-
31	376/079	Screw	-	3	3	-
32	376/088	Needle seating	-	1	1	-
33	376/089	Needle	-	1	1	-
34	376/093	Filter	-	1	1	-
35	376/091	Bolt	-	1	1	-
36	376/092	Fibre washer	-	1	1	-
37	376/086	Tickler	-	1	1	-
38	376/087	Spring	-	1	1	-
39	343/011	Tickler body	-	1	1	-
40	244/1048	"O" ring seal	-	1	1	-
41	376/066	Air intake tube	-	A	A	-
42	E1987	Stud (1 $\frac{11}{32}$ in. O.A.)	-	2	2	-
43	E4051	Joint washer	-	1	1	-
44	E4213	Adaptor	-	1	1	-
45	S25-13	Plain washer	-	2	2	-
46	W103	Nut	-	2	2	-
47	E1553	Stud (1 $\frac{3}{32}$ in. O.A.)	-	2	2	-
48	S25-3	Plain washer	-	2	2	-
49	S1-51	Nut	-	2	2	-
50	F4886	Petrol pipe	-	1	1	-

CARBURETTER COMPLETE REF. N° 1

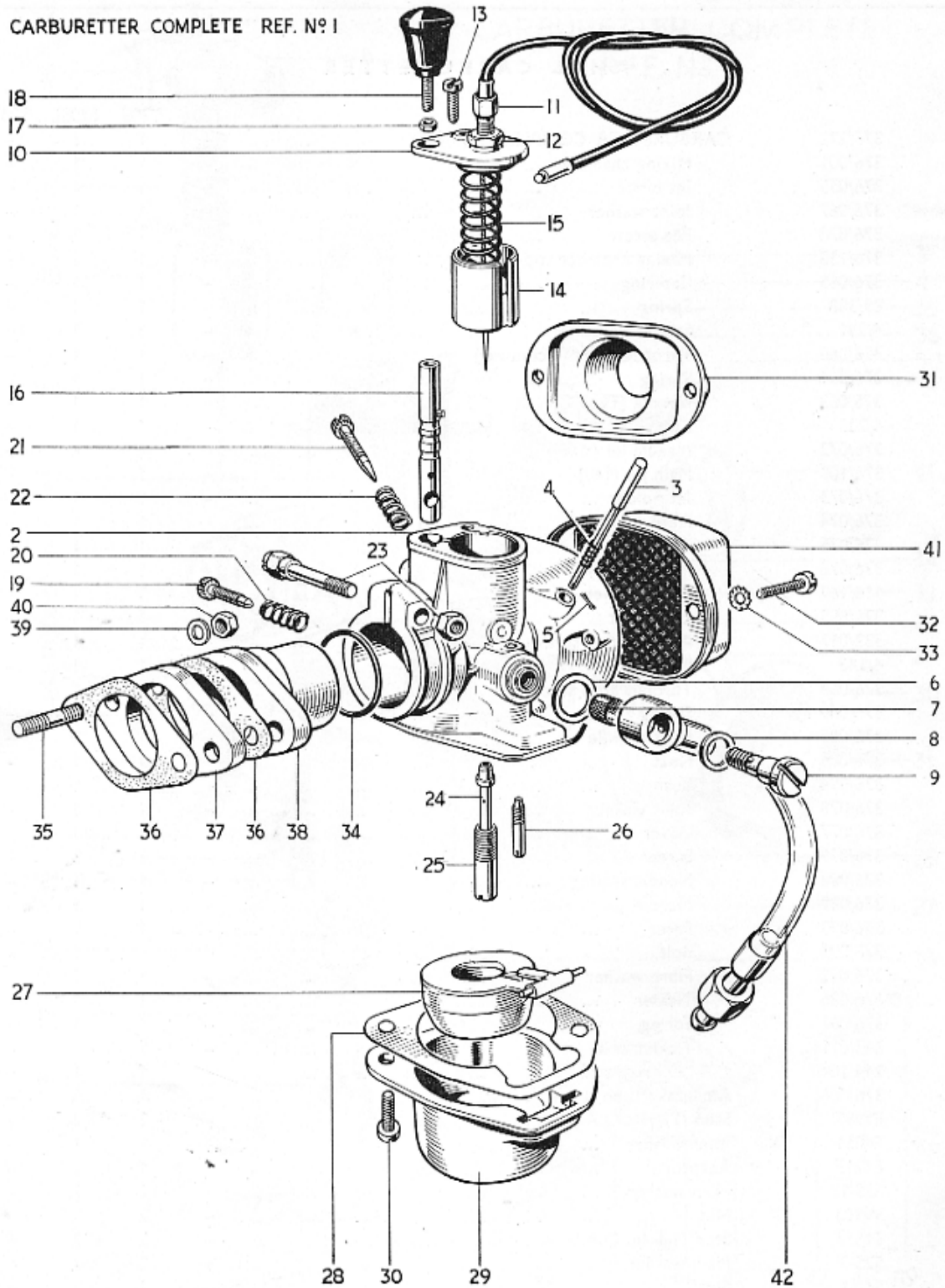

Fig. 24. ZENITH CARBURETTER.

ZENITH CARBURETTER

								T20	T20S	T20SL	T20T
1	18MXZ-C17	CARBURETTER C/W THROTTLE CABLE	1	-	-	-
1	18MXZ-C18	CARBURETTER C/W THROTTLE CABLE	-	-	-	1
2	018606	Body	1	-	-	1
3	018027	Tickler	1	-	-	1
4	015454	Spring	1	-	-	1
5	05889	Split pin	1	-	-	1
6	017129	Fibre washer	1	-	-	1
7	017130	Filter gauze	1	-	-	1
8	017132	Fibre washer	1	-	-	1
9	018063	Union bolt	1	-	-	1
10	017581	Mixing chamber top	1	-	-	1
11	017988	Cable adjuster	1	-	-	1
12	017464	Nut	1	-	-	1
13	07087	Screw	1	-	-	1
14	017624	Throttle slide	1	-	-	1
15	017625	Spring	1	-	-	1
16	018601	Starter slide (200/65)	1	-	-	1
17	015536	Spring washer	1	-	-	1
18	018595	Knob	1	-	-	1
19	017144	Throttle stop screw	1	-	-	1
20	017156	Spring	1	-	-	1
21	018607	Pilot air screw	1	-	-	1
22	09846	Spring	1	-	-	1
23	017797	Clamp screw and nut	1	-	-	1
24	017135	Emulsion tube	1	-	-	1
25	017134	Main jet (84)	1	-	-	1
26	017133	Slow running jet (45)	1	-	-	1
27	017588	Float	1	-	-	1
28	017735	Joint washer	1	-	-	1
29	017583	Float bowl	1	-	-	1
30	07087	Screw	2	-	-	2
31	017570	Intake adaptor (E3955)	-	-	-	1
32	07967	Screw	2	-	-	2
33	04692	Spring washer	2	-	-	2
34	018042	"O" ring	1	-	-	1
35	E3171	Stud (1 $\frac{5}{32}$ in. O.A.)	2	-	-	2
36	E3250	Joint washer	2	-	-	2
37	E3254	Insulating block	1	-	-	1
38	E3954	Carburetter adaptor	1	-	-	1
39	S25-13	Plain washer	2	-	-	2
40	F879	Nut	2	-	-	2
41	E3981	Air filter	1	-	-	-
42	F4537	Petrol pipe	1	-	-	1

CONTACT BREAKER ASSEMBLY REF. N° 1

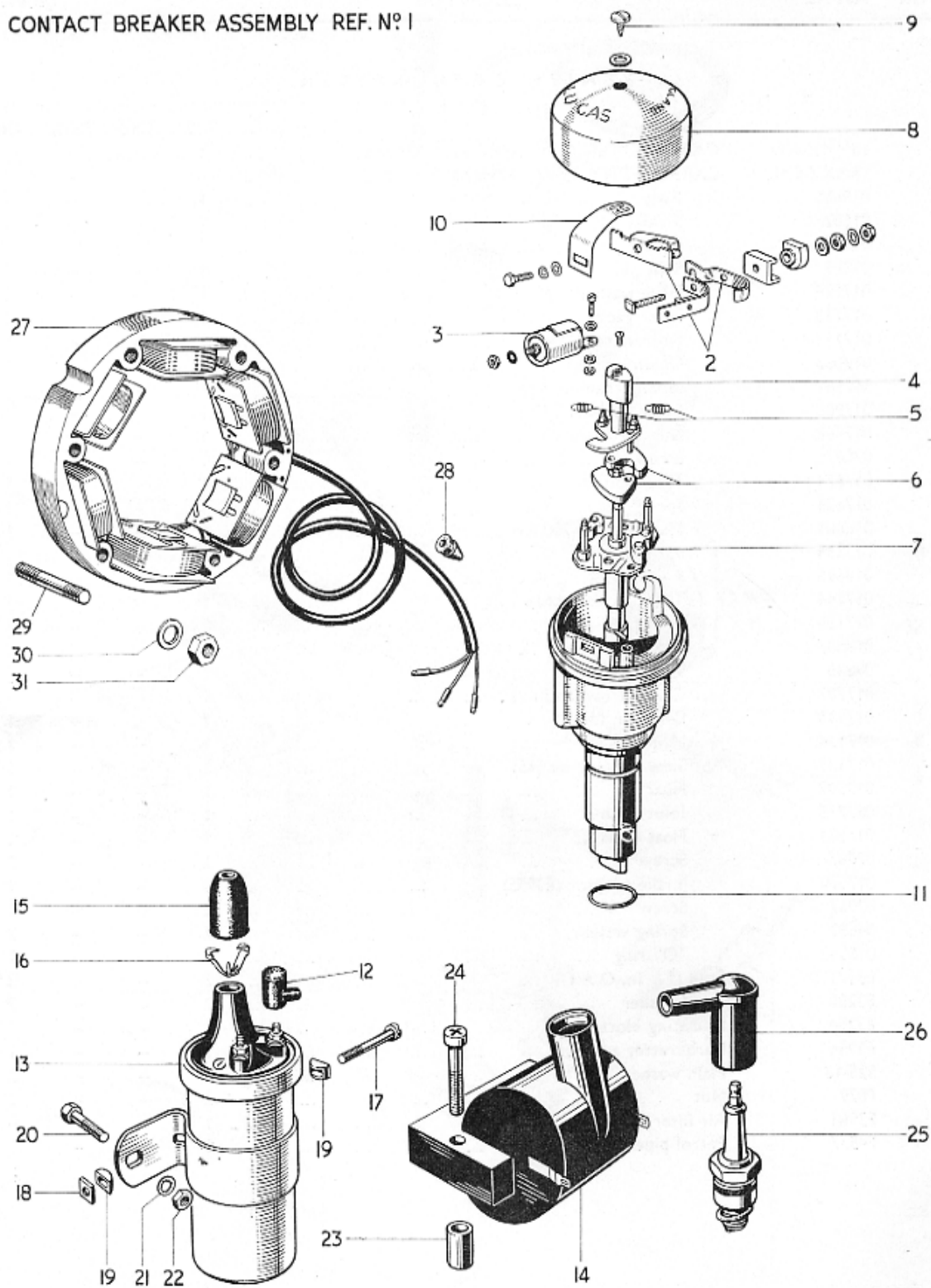

Fig. 25. CONTACT BREAKER, COIL AND STATOR.

CONTACT BREAKER, COIL AND STATOR

							T20	T20S	T20SL	T20T
1	40699	CONTACT BREAKER 15DI	1	-	-	-
1	40700	CONTACT BREAKER 15DI	-	1	1	1
2	421106	Contact set	1	1	1	1
3	421327	Condenser	1	1	1	1
4	423759	Cam	1	-	-	-
4	54411249	Cam	-	1	1	1
5	421407	Spring set	1	-	-	-
5	54410895	Spring set	-	1	1	1
6	421056S	Weight set	1	1	1	1
7	421054	Shaft and action plate	1	1	1	1
8	54411737	Cover	1	1	1	1
9	54120019	Screw	1	1	1	1
10	54411736	Bracket	1	1	1	1
11	54160003	Oil seal	1	1	1	1
12	236741	Grommet	3	1	1	1
13	45077	Coil, MA6	1	-	-	-
14	45112	Coil, 2ET	-	1	1	1
15	421554	Grommet	1	1	1	1
16	421863	Cable clip	1	1	1	1
17	100104	Clip screw	1	-	-	-
18	169160	Square nut	1	-	-	-
19	422369	"D" washer	2	-	-	-
20	DS57	Bolt ($\frac{7}{16}$ in. U.H.)	2	-	-	-
21	E1612	Serrated washer	2	-	-	-
22	F879	Nuc	2	-	-	-
23	F3477	Spacer	-	2	2	2
24	T1401	Screw ($2\frac{1}{8}$ in. U.H.)	-	2	2	2
25		Sparking plug (Champion L7, KLG 80 or Lodge HN)	1	1	1	1
26	D297	Plug cover and suppressor	1	1	1	1
26	D262	Plug cover	A	A	A	A
27	47119	Stator	1	-	-	-
27	47177	Stator	-	1	1	1
28	E4185	Grommet	1	1	1	1
29	E3718	Stud ($1\frac{5}{16}$ in. O.A.)	5	5	5	5
30	S25-13	Plain washer	5	5	5	5
31	E4186	Self-locking nut...	5	5	5	5

CONTACTS, COIL AND STATOR

NO.	DESCRIPTION	QTY.
1	CONTACTS	1000
2	COILS	1000
3	STATOR	1000
4
5
6
7
8
9
10
11
12
13
14
15
16
17
18
19
20
21
22
23
24
25
26
27
28
29
30
31
32
33
34
35
36
37
38
39
40
41
42
43
44
45
46
47
48
49
50
51
52
53
54
55
56
57
58
59
60
61
62
63
64
65
66
67
68
69
70
71
72
73
74
75
76
77
78
79
80
81
82
83
84
85
86
87
88
89
90
91
92
93
94
95
96
97
98
99
100

PRINTED IN ENGLAND
by
H. A. SMITH & SON LIMITED
BURNSALL ROAD
COVENTRY

