

1958

TRIUMPH

TIGER CUB

REPLACEMENT
PARTS
CATALOGUE
No. 5

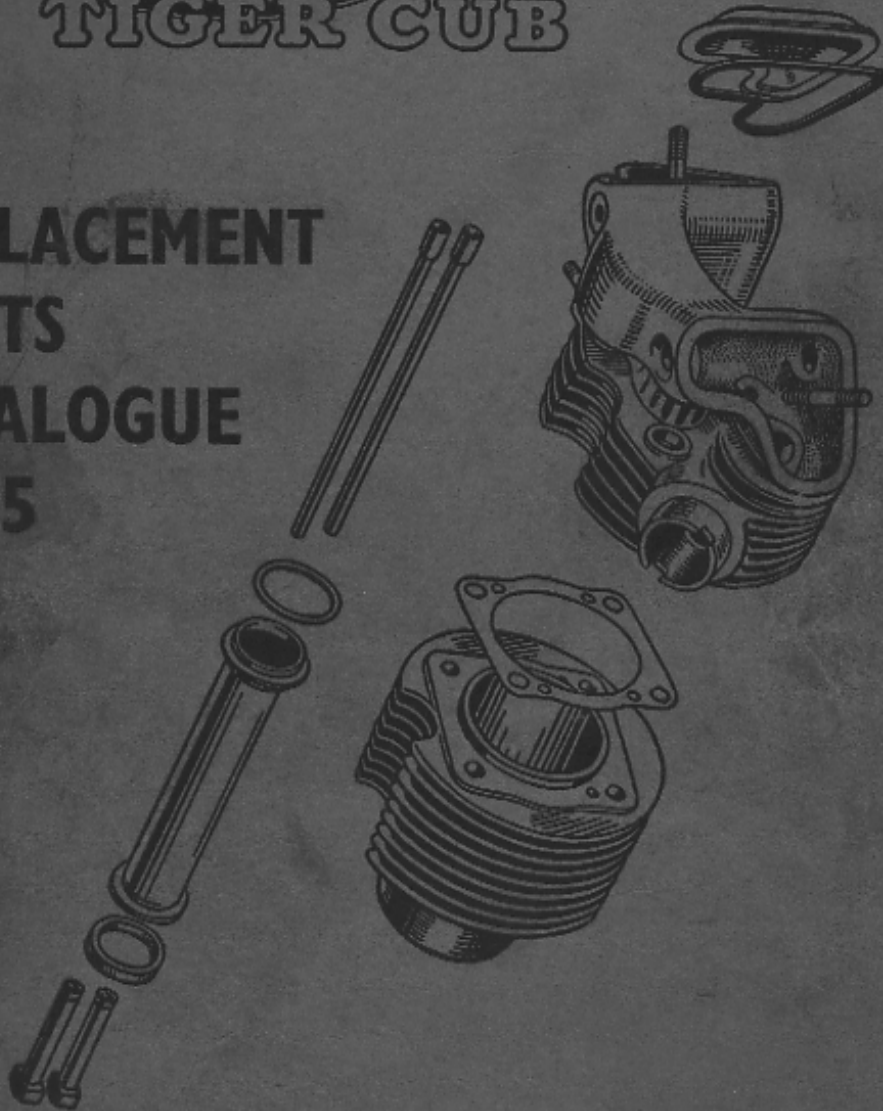

TRIUMPH ENGINEERING CO. LTD.
Meriden Works, Allesley
COVENTRY.

REPLACEMENT PARTS

CATALOGUE No. 5

for the

TRIUMPH TIGER CUB

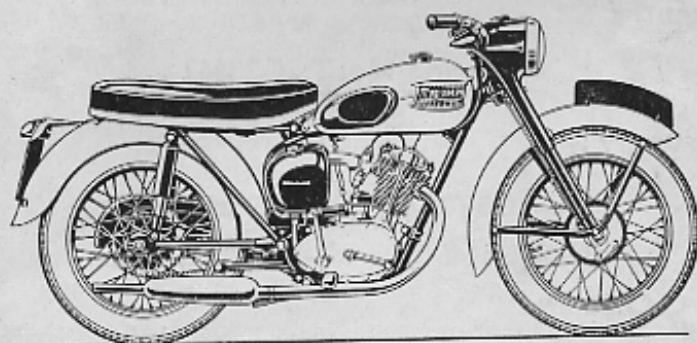

200cc O.H.V.
Models T20 and T20C

From Engine No. 26276

Triumph Engineering Co. Ltd., Meriden Works, Allesley, Coventry
Tel. Meriden 331 Ref. 390/58 Published Jan. 1958

PREFACE

BEFORE ordering parts for your machine, please read very carefully the instructions contained in the next paragraph. In many cases the information given in the order is insufficient to enable us to identify the customers' requirements with certainty. Delay is frequently occasioned by our having to refer the order back for further particulars before we can supply.

HOW TO ORDER. Every part is indicated by a number and this should be quoted together with the description. In order to assist customers, parts where possible have been listed in order of assembly and exploded illustrations show the assembly order also. By each illustration, is an index quoting the part numbers of the various items and a cross reference to enable the customer to recognise the part by description (See page 59 for further details). With these aids there should be no difficulty in identifying the parts you require. Always quote the engine number and prefix letter stamped on the front engine fixing lug. Always use a separate sheet of writing paper for your order if you are sending a letter as well.

SPECIMEN ORDER

To Triumph Engineering Co. Ltd.,
Spares Department,
Meriden Works,
Allesley,
Coventry.

2/6/57

Engine No. T.20-28462

Please supply :—

1 — GST20/56 — Gasket Set
1 — E3146 — Valve, Inlet

* Send C.O.D.

Wm. Smith,
1a, Ewell Avenue,
Ewell, Surrey.

* For terms of business see page 3

TELEGRAPHIC ORDERS. Orders by telegram should be addressed to "Trusty 60221 Coventry." They are then telephoned to us, which prevents delay in delivery. It is only necessary to quote part numbers in telegraphic orders, the description can be omitted.

PATTERNS AND PARTS FOR REPAIR. It is not necessary to send patterns if the part number is quoted. The sending of patterns often delays the order as parcel post or rail takes longer than letter post.

Parts sent to Coventry for repair, replacement or as patterns, should bear the sender's name and address and clear instructions should accompany the parts. All parts must be forwarded carriage paid and care should be taken to ensure that all remittances are sent separately and not enclosed with the parts. Fragile units such as cylinders, etc., should always be boxed to avoid damage in transit. Complete machines should have all fitments such as horns, driving mirrors, tools, etc., removed by the sender before despatch, as it is impossible for us to accept responsibility in the event of loss in transit. We are always pleased to give estimates for overhauls and repairs, but should an estimate not be accepted, a charge will be made covering cost of dismantling and re-assembling, if carried out.

Communications relating to parts should be addressed to the SPARES MANAGER and for repairs, guarantee claims and technical advice to the SERVICE MANAGER.

In order to facilitate quick reference, the quoting of any order number, invoice number or reference from previous communications is of essential importance. **Accessories not of our manufacture should be sent direct to the actual makers, whose names and addresses appear on page 47.**

WHERE TO OBTAIN. Triumph Replacement Parts may be obtained from any Triumph Dealer, and we recommend our customers to place their orders with the Triumph Dealer in their district, as we do not normally supply direct. When parts not usually asked for are required, and for which the Dealer may have to wire or obtain specially, the postage or carriage incurred becomes payable.

We are not able to supply Transfers as originally affixed to Triumph Motor Cycles, but we are at all times willing to supply a Transfer denoting that the machine is of genuine Triumph manufacture, providing the Frame and Engine prefix letters and numbers are quoted.

Customers are warned against the risk incurred by purchasing parts which are not of genuine Triumph manufacture. The risk is eliminated if parts are ordered as instructed, either from our recognised Dealers, or direct from the Spares Department, Meriden Works, Allesley, Coventry.

TERMS OF BUSINESS

THE most convenient method of paying for spare parts is by the C.O.D. system. By this method you pay the postman for the goods when he delivers them to you. As the minimum C.O.D. collection fee is 1/2 only goods to the value of 2/- or over can be sent by this system. We do not despatch goods by rail C.O.D.

Where goods are not sent C.O.D., cash must accompany the order. All remittances should be made payable to the Triumph Engineering Co., Ltd., and crossed "Barclay's Bank Ltd.", if in the form of Postal Order or Cheque. Letters containing currency notes must be registered.

Should a remittance be forwarded by telegraphic money order, the name and address of the sender must be inserted in the space provided on the Post Office requisition form for a private message from remitter to payee. Unless this is complied with the Post Office omit such information from the telegram and we are not then in a position to trace the sender.

Postage, carriage and packing is charged at 5% on the value of the goods, minimum charge 1/-. Packing boxes, cases, crates, etc., are charged for at cost and are returnable.

TRIUMPH
TIGER CUB

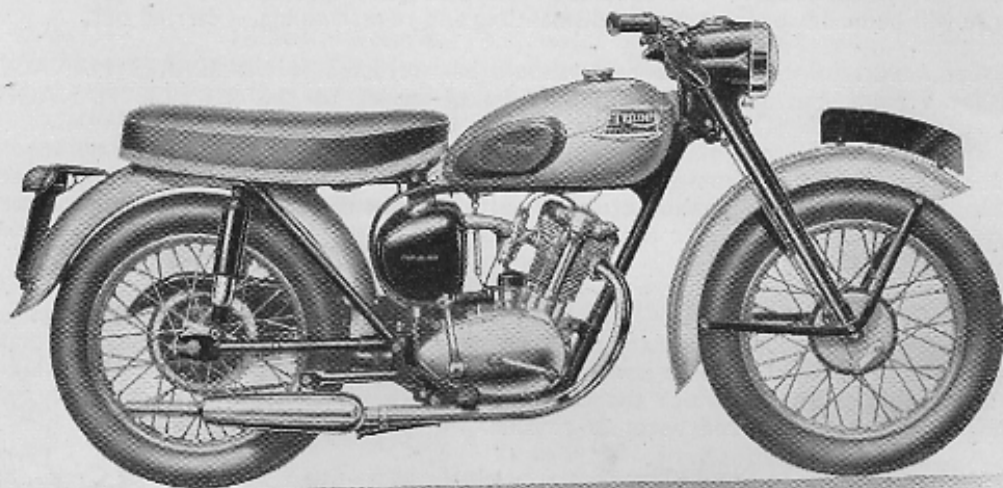

MODEL T20

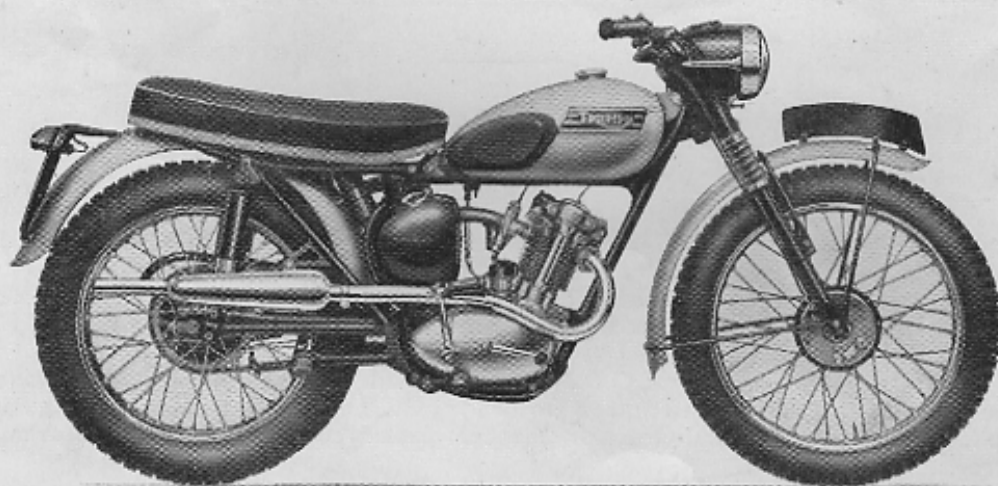

MODEL T20C

CARTON PACK — GROUP I

CARTON PACK — GROUP I

The following sub-assemblies are supplied in carton packs under the C.P. part number stated. The contents of these carton packs are preserved and will not deteriorate under adverse conditions.

<i>Part No.</i>	<i>Description and Contents</i>							
Big End Assembly								
CP.155	...	1	E3624	Connecting rod c/w bushes
		1	E3600	Crankpin c/w plug
Brake linings								
CP.128	...	2	W978	Linings
		14	W979	Rivets
Piston Assembly								
CP.141	...	1	E3358	Piston body
		1	E3380	Ring, chrome compression
		1	E656	Ring, compression
		1	E3387	Ring, scraper
		1	E1750	Pin, gudgeon
		2	E1767	Circlip, gudgeon pin
Piston Rings								
CP.150	...	1	E3380	Ring, chrome compression
		1	E656	Ring, compression
		1	E3387	Ring, scraper
Steering Races								
CP.129	...	2	H835	Cup, steering race
		2	H833	Cone, steering race
		30	S70-3	Ball, steering race
Valves								
CP.124	...	1	E3146	Valve, inlet
		1	E3147	Valve, exhaust
Valve Guides								
CP.122	...	2	E3208	Valve guide, inlet and exhaust
		2	E3209	Circlip
Valve Springs								
CP.123	...	2	E3214	Spring, valve inner
		2	E3215	Spring, valve outer

For Indexes see Pages 56 to 59

GROUP 2 — ENGINE

REPLACEMENT PARTS

REF. No. PART No. DESCRIPTION QUANTITY

ENGINE — GROUP 2

Illustrated on Page 10—Fig. 1

								T20	T20C
CYLINDER BARREL									
1	E3385	Barrel, cylinder	1	1	
2	E3386	Dowel, cylinder barrel to head	2	2	
3	E3368	Washer, cylinder base	1	1	
PISTON									
4	CPI41	Piston c/w rings, gudgeon pin, etc.	1	1	
5	E656	Ring, compression (top)	1	1	
6	E3048	Ring, compression (taper)	1	1	
7	E3387	Ring, oil control	1	1	
8	E1750	Pin, gudgeon	1	1	
9	E1767	Circlip, gudgeon pin	2	2	
CYLINDER HEAD									
10	E3661	Head, cylinder c/w guides and adaptor	1	1	
11	E3217	Gasket, cylinder head	1	1	
12	E3207	Adaptor, cylinder head exhaust	1	1	
13	E3210	Stud, rocker inspection cover	2	2	
14	E1987	Stud, cylinder head to carburetter	2	2	
15	E3230	Nut, cylinder head to barrel	4	4	
16	E3446	Washer, cylinder head to barrel	4	4	
OVERHEAD ROCKERS, COVERS									
17	E3251	Rocker, inlet assembly	1	1	
18	E3252	Rocker, exhaust assembly	1	1	
19	E3222	Ball pin, rocker	2	2	
20	E3223	Adjuster, rocker	2	2	
21	GS662	Locknut, rocker adjuster pin	2	2	
22	E3225	Spindle, rocker inlet and exhaust	2	2	
23	E3253	Sealing ring, rocker spindle	2	2	
24	E2534	Thrust washer, rocker spindle L.H.— $\frac{7}{16}$ "	4	4	
25	E2594	Thrust washer, rocker spindle R.H.— $\frac{3}{8}$ "	2	2	
26	E3224	Thackeray washer, washer, rocker spindle (spring)	2	2	
27	E3227	Cover, rocker inlet inspection	1	1	
28	E3228	Cover, rocker exhaust inspection	1	1	
29	E3226	Washer, rocker cover joint	2	2	
30	E3290	Nut, rocker cover to head	2	2	
31	E2441	Washer, rocker cover to head nut	2	2	

ENGINE — GROUP 2

REF. No.	PART No.	DESCRIPTION	QUANTITY	
VALVES, GUIDES & SPRINGS			T20 T20C	
1	E3146	Valve, inlet	1	1
2	E3147	Valve, exhaust	1	1
3	E3208	Guide, inlet and exhaust	2	2
4	E3209	Circlip, inlet and exhaust guide	2	2
5	E3214	Spring, valve inner	2	2
6	E3215	Spring, valve outer	2	2
7	E3301	Collar, valve spring top	2	2
8	E3213	Cup, valve spring bottom	2	2
9	WE259A	Cotter, valve split	4	4
PUSH RODS AND COVER				
10	E3372	Rod, push	2	2
11	E3537	Cover, push rod	2	1
12	E3172	Peg, cover to crankcase locating	1	1
13	E3540	Washer, push rod cover joint (upper)	1	1
14	E3391	Washer, push rod cover joint (lower)	1	1
TAPPETS				
15	E3285	Tappet	2	2
ROCKER OIL PIPE				
16	E3244	Pipe, rocker oil	1	1
17	H400	Nut, rocker oil pipe to spindle	2	2
18	E1335	Washer, rocker oil pipe inner joint	2	2
19	E3249	Washer, rocker oil pipe outer joint	2	2
20	E3383	Connection, oil tank to oil pipe (Rubber)	1	1
FLYWHEELS AND CONNECTING ROD				
21	E3653	Flywheels and connecting rod assembly	1	1
22	E3596	Flywheels c/w mainshaft L.H.	1	1
23	E3598	Flywheels c/w plugs R.H.	1	1
24	E3420	Plug, R.H. Flywheel	2	2
25	E3624	Rod, connecting with bushes	1	1
26	E3623	Bush, big end	1	1
27	E1762	Bush, small end	1	1
28	E3600	Crankpin c/w plugs	1	1
29	E3292	Plug, crankpin	2	2
SPECIAL NOTE. Subsequent to Engine No. 35847 use :				
30	E3909	Flywheel and connecting rod assembly	1	1
31	E3910	Flywheel, c/w mainshaft L.H.	1	1

GROUP 2 — ENGINE

REF. No.	PART No.	DESCRIPTION	QUANTITY	
T20 T20C				
CRANKCASE				
1	E3563	Crankcase assembly c/w bushes	1	1
2	E3365	Stud, crankcase to cylinder head	4	4
3	E3171	Stud, crankcase to oil pipe junction block	1	1
4	T989	Dowel, crankcase to R.H. inner cover	2	2
5	E3169	Dowel, crankcase to oil junction block	1	1
6	E3560	Pipe, crankcase oil return	1	1
7	T1076	Screw, crankcase oil return pipe	1	1
8	E2615	Plug, crankcase oil gauge test hole	1	1
9	E1335	Washer, crankcase plug	1	1
SPECIAL NOTE. Subsequent to Engine No. 35847 use :				
10	E3930	Crankcase assembly c/w bushes	1	1
CRANKCASE BEARINGS (ENGINE)				
11	E3655	Bearing, R.H. (Plain)	1	1
12	E3172	Peg, R.H. bearing	1	1
13	E3175	Bush, camshaft	1	1
14	E3518	Bush, distributor and oil pump shaft	1	1
15	E3152	Bearing, L.H. (Ball journal)	1	1
16	E3379	Oil Seal, L.H. Bearing	1	1
TIMING GEARS AND CAMSHAFT				
17	E3178	Pinion, timing and distributor drive	1	1
18	E3421	Bolt, timing and distributor pinion	1	1
19	E3185	Pinion, camshaft (50T)	1	1
20	E3184	Key, camshaft pinion	1	1
21	E3183	Camshaft, inlet and exhaust	1	1
22	E3186	Pinion and shaft, distributor and oil pump drive	1	1
OIL PUMP				
23	E3393	Oil pump assembly	1	1
24	E3409	Body, oil pump	1	1
25	E3410	Plunger, oil feed	1	1
26	E3194	Plunger, oil scavenge	1	1
27	E3195	Rod, connecting drive	1	1
28	E3412	Pin, connecting drive rod	1	1
29	E3413	Circlip, connecting drive rod	1	1
30	S70-4	Ball, oil pump body	2	2
31	E3191	Spring, oil pump body and auxiliary valves	4	4
32	T1124	Ball, auxiliary valve	2	2

ENGINE — GROUP 2

REF. No.	PART No.	DESCRIPTION	QUANTITY	
			T20	T20C
1	E3192	Plug, oil pump body	2	2
2	E3197	Bolt, oil pump to crankcase $\frac{11}{16}$ in. U.H.	2	2
3	GS299	Lockwasher, oil pump to crankcase (serrated)	2	2
4	E3188	Washer, oil pump to crankcase joint	1	1
CRANKCASE FILTER				
5	E3177	Filter, crankcase	1	1
6	E3176	Spring, crankcase filter	1	1
7	E3302	Washer, crankcase filter spring	1	1
8	E1564	Cap, crankcase filter	1	1
9	E1577	Washer, crankcase filter joint	1	1
INNER COVER, LEFT SIDE				
10	E3664	Cover, crankcase inner c/w dowels	1	1
11	E3199	Dowel, inner cover to crankcase front	1	1
12	T989	Dowel, inner cover to outer cover rear	1	1
13	E3460	Sealing washer, gearbox shaft (rubber)	1	1
14	E3603	Backing washer, sealing washer	1	1
15	E3204	Screw, inner cover to crankcase 1 in. U.H.	1	1
16	E3445	Screw, inner cover to crankcase $\frac{11}{16}$ in. U.H....	2	2
17	DS57	Plug, oil level and drain... ..	2	2
18	WE170	Washer, oil level and drain plugs	2	2
SPECIAL NOTE. Subsequent to Engine No. 35847 use :				
19	E3915	Cover, crankcase L.H. inner c/w dowels	1	1
20	T1492	Dowel, inner cover to crankcase front	1	1
21	E3932	Sealing washer, gearbox shaft (rubber)	1	1
22	E3933	Retainer, sealing washer	1	1
ENGINE SPROCKET				
23	E3581	Engine sprocket, 18 teeth	1	1
24	W954	Distance piece, sprocket and rotor	1	1
SPECIAL NOTE. Subsequent to Engine No. 35847 use :				
25	E3912	Engine sprocket, 19 teeth Duplex	1	1
26	E3913	Distance piece sprocket and rotor	1	1
OUTER COVER, LEFT SIDE				
27	E3667*	Cover, L.H. outer	1	1
28	E3579	Washer, cover joint	1	1
29	E3205	Screw, outer cover, $1\frac{1}{2}$ in. U.H.	4	4
30	E3200	Screw, outer cover, $\frac{11}{16}$ in. U.H.	2	2
31	E3668	Screw, outer cover $\frac{3}{8}$ in. U.H.	2	2
32	E3204	Screw, outer cover, 1 in. U.H.	1	1

*See also Page 12.

GROUP 2 — ENGINE

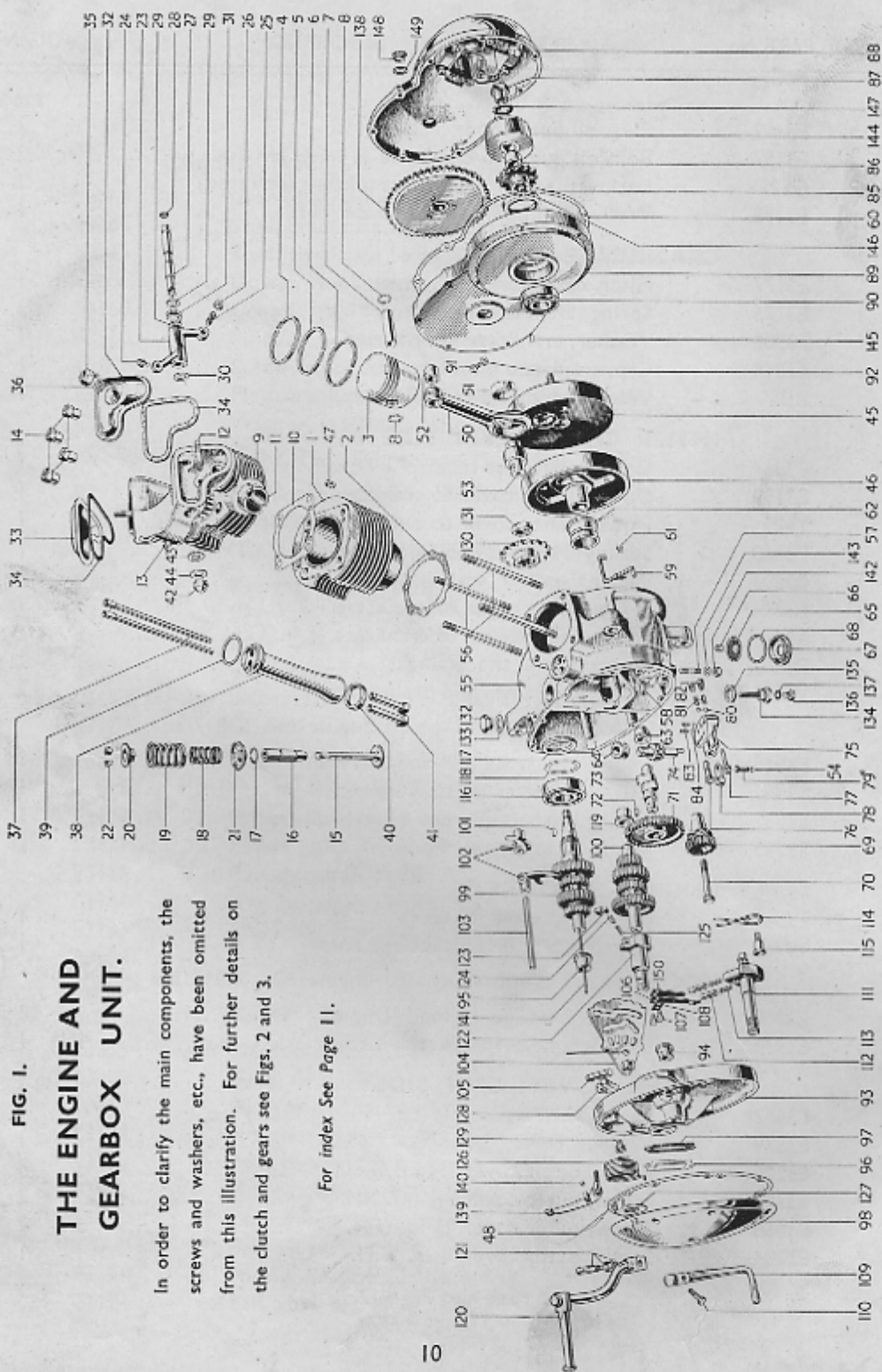

FIG. 1.

THE ENGINE AND GEARBOX UNIT.

In order to clarify the main components, the screws and washers, etc., have been omitted from this illustration. For further details on the clutch and gears see Figs. 2 and 3.

For index See Page 11.

ENGINE — GROUP 2

INDEX TO FIG. 1 — PAGE 10

Illust. No.	Part No.	Page No.	Ref. No.	Illust. No.	Part No.	Page No.	Ref. No.	Illust. No.	Part No.	Page No.	Ref. No.
1	E3385	6	1	53	E3600	7	28	101	T1119	15	31
2	E3368	6	3	54	E3413	8	29	102	T1098	13	13
3	CPI41	6	4	55	See Page 8			103	T1102	13	14
4	E656	6	5	56	E3365	8	2	104	T1066	13	15
5	E3048	6	6	57	E3171	8	3	105	T1069	13	16
6	E3387	6	7	58	T989	8	4	106	T1248	13	18
7	E1750	6	8	59	E3560	8	6	107	T1076	13	20
8	E1767	6	9	60	E3579	9	28	108	T1180	13	21
9	E3661	6	10	61	T1076	8	7	109	T1164	13	22
10	E3217	6	11	62	E3655	8	11	110	F1369	13	23
11	E3207	6	12	63	E3175	8	13	111	T1259	13	24
12	E3210	6	13	64	E3518	8	14	112	T1184	13	25
13	E1987	6	14	65	E3177	9	5	113	T1278	13	27
14	E3230	6	15	66	E3176	9	6	114	T1109	13	29
15	E3146 (in)	7	1	67	E1564	9	8	115	T1077	13	30
	E3147 (ex)	7	2	68	E1577	9	9	116	T1070	14	1
16	E3208	7	3	69	E3178	8	17	117	See Page 14		
17	E3209	7	4	70	E3421	8	18	118			
18	E3214	7	5	71	E3185	8	19	119	T1073	14	4
19	E3215	7	6	72	E3184	8	20	120	T1165	15	1
20	E3301	7	7	73	E3183	8	21	121	S52-1	15	8
21	E3213	7	8	74	E3186	8	22	122	T1279	15	9
22	WE259A	7	9	75	E3409	8	24	123	T1281	15	11
23	E3251 (in)	6	17	76	E3194	8	26	124	T1282	15	12
24	E3252 (Ex)	6	18	77	E3410	8	25	125	T1161	15	13
25	E3222	6	19	78	E3195	8	27	126	T1162	15	15
26	G5662	6	20	79	E3412	8	28	127	T1163	15	16
27	E3225	6	21	80	S70-4	8	30	128	T1157	15	17
28	E3253	6	22	81	E3191	8	31	129	T1158	15	18
29	E2534	6	23	82	E3192	9	1	130	See Page 15		
30	E2594	6	24	83	E3191	8	31	131	T1082	15	23
31	E3224	6	25	84	T1124	8	32	132	T1110	15	24
32	E3228	6	26	85	E3581	9	23	133	E697	15	25
33	E3227	6	27	86	E3912	9	25	134	T1112	15	26
34	E3226	6	28	87	W954	9	24	135	T1257	15	27
35	E3290	6	29	88	E3913	9	26	136	T361	15	28
36	E2441	6	30	89	465909	48	9	137	WE170	15	29
37	E3372	7	10	90	E3667	9	27	138	See Pages 15 and 16		
38	E3537	7	11	91	E3917	12	5	139	T1233	16	23
39	E3540	7	13	92	E3664	9	10	140	T1124	16	27
40	E3391	7	14	93	E3915	9	19	141	T1140	16	30
41	E3285	7	15	94	E3152	8	15	142	F879	41	14
42	H400	7	17	95	DS57	9	17	143	S25-13	41	15
43	E1335	7	18	96	WE170	9	18	144	466124	48	2
44	E3249	7	19	97	E3476	12	8	145	E1580	48	8
45	See Page 7	7	23	98	E3293	12	9	146	E3379	8	16
46	E3598	7	25	99	T1147	12	11	147	46910	48	10
50	E3624	7	26	100	T1149	12	12	148	E732	12	3
51	E3623	7	26		T1148	12	13	149	NE507	12	4
52	E1762	7	27		E3151	12	20	150	T1249	13	19

GROUP 2 — ENGINE

REF. No.	PART No.	DESCRIPTION	QUANTITY	
			T20	T20C
1	E2386	Domed nut, middle screws	2	2
2	E2441	Washer, copper	2	2
3	E732	Plug, oil filler	1	1
4	NE507	Washer, oil filler plug	1	1
SPECIAL NOTE. Subsequent to Engine No. 35847 use :				
5	E3917	Cover, L.H. outer	1	1
6	E3914	Screw, outer cover $1\frac{1}{4}$ in. U.H.	4	4
7	E3205	Screw, outer cover $1\frac{1}{4}$ in. U.H.	2	2

INNER COVER, RIGHT SIDE

8	E3476	Cover, inner c/w bushes and clutch lever	1	1
9	E3293	Bush, camshaft	1	1
10	E3172	Peg, camshaft bush	1	1
11	T1147	Bush, gearbox mainshaft	1	1
12	T1149	Plate, inner cover	1	1
13	T1148	Washer, inner cover plate (Cork)	1	1
14	T1150	Screw, inner cover plate 0.41 in. U.H.	2	2
15	E3204	Screw, inner cover to crankcase 1 in. U.H.	2	2
16	E3220	Screw, inner cover to crankcase $\frac{11}{16}$ in. U.H.	1	1
17	E3221	Screw, inner cover to crankcase $1\frac{1}{8}$ in. U.H.	1	1
18	F3775	Vent pipe, inner cover breather (PVC)	1	1
19	XA69	Clip, vent pipe to clutch cable	1	1

OUTER COVER, RIGHT SIDE

20	E3151	Cover, outer R.H.	1	1
21	E3345	Washer, cover joint	1	1
22	E3221	Screw, outer R.H. cover $1\frac{1}{8}$ in. U.H.	1	1
23	E3231	Screw, outer R.H. cover $1\frac{3}{8}$ in. U.H.	7	7
24	E3220	Screw, outer R.H. cover $\frac{11}{16}$ in. U.H.	1	1

GASKET SET

25	GST20/56	Gasket set	1	1
----	----------	-------------------	---	---

GEARBOX — GROUP 3

REF. No.	PART No.	DESCRIPTION	QUANTITY
----------	----------	-------------	----------

GEARBOX AND CLUTCH — GROUP 3

Illustrated on Pages 10, 14 and 17—Figs. 1, 2 and 3

			T20	T20C
SHAFTS AND GEARS				
1	T1083*	Gear cluster, mainshaft (3rd and low)	1	1
2	T1085	Bush, mainshaft clutch rod	1	1
3	T1078	Gear, mainshaft high c/w bush... ..	1	1
4	T1080	Bush, high gear	1	1
5	T1089	Gear, mainshaft 2nd	1	1
6	T1090	Thrust ring, mainshaft 2nd gear	1	1
7	T1091*	Gear, cluster, layshaft (top and 2nd)	1	1
8	T1094	Gear, layshaft 3rd	1	1
9	T1095	Gear, layshaft low c/w bush	1	1
10	T1097	Bush, layshaft low gear	1	1
* The gear clusters are sold only as an assembly and the parts cannot be obtained separately.				
SPECIAL NOTE. Subsequent to Engine No. 35847 use :				
11	T1514	Gear, mainshaft high c/w bush... ..	1	1
12	T1515	Bush, high gear	1	1
SELECTOR FORKS AND SPINDLE				
13	T1098	Fork, mainshaft and layshaft selector	2	2
14	T1102	Spindle, selector fork	1	1
CAMPLATE				
15	T1066	Camplate assembly	1	1
16	T1069	Spindle, camplate	1	1
17	$\frac{3}{16}$ " x 1"	Split pin, camplate to spindle	1	1
18	T1248	Spring, camplate index	1	1
19	T1249	Spring, camplate index (supplementary)	1	1
20	T1076	Screw, camplate index spring	2	2
21	T1180	Lockwasher, camplate index spring	1	1
GEARCHANGE MECHANISM				
22	T1164	Pedal, gear change	1	1
23	F1369	Bolt, gear change pedal	1	1
24	T1259	Spindle, quadrant and plunger assembly	1	1
25	T1181	Feltwasher, gear change spindle	1	1
26	T1184	Plunger, gear change selector	2	2
27	T1278	Spring, gear change selector plunger	2	2
28	$\frac{1}{16}$ " x $\frac{3}{4}$ "	Split pin, gear change selector plunger	2	2
29	T1109	Spring, gear change return	1	1
30	T1077	Pin, gear change return spring anchorage	1	1
31	E2287	Washer, gear change return spring anchorage	1	1
32	T449	Rubber, gear change pedal	1	1

GROUP 3 — GEARBOX

REF. No.	PART No.	DESCRIPTION	QUANTITY	
GEARBOX CASING BEARINGS			T20	T20C
1	T1070	Bearing, L.H. gearbox mainshaft (ball)		
2	T1071	Oil seal, L.H. bearing (felt)		
3	T1072	Plate, L.H. bearing seal retaining		
4	T1073	Bearing, L.H. gearbox layshaft (plain)		
5	E3172	Peg, layshaft bearing locating		
6	T1269	Disc, L.H. gearbox layshaft bearing		
SPECIAL NOTE. Subsequent to Engine No. 35847 use :				
7	H1168	Oil seal, L.H. bearing		

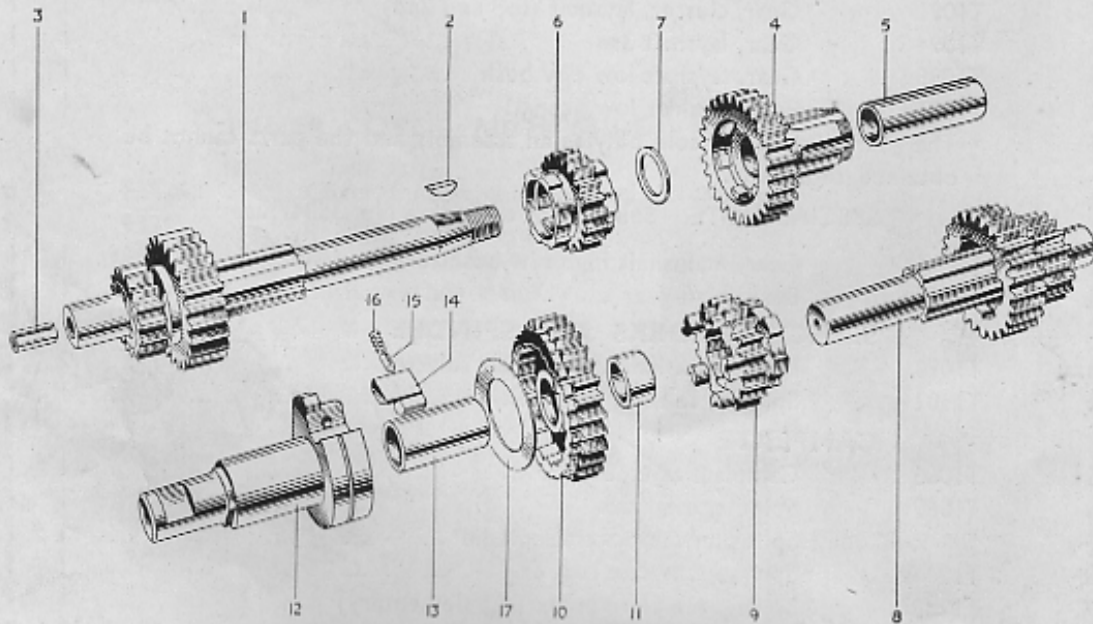

FIG. 2. MAINSHAFT AND LAYSHAFT GEARS.

INDEX

Illust. No.	Part No.	Page No.	Ref. No.	Illust. No.	Part No.	Page No.	Ref. No.
1	T1083	13	1	9	T1094	13	8
2	T1119	15	31	10	T1095	13	9
3	T1085	13	2	11	T1097	13	10
4	T1078	13	3	12	T1279	15	9
	T1514	13	11	13	T1118	15	10
5	T1080	13	4	14	T1281	15	11
	T1515	13	12	15	T1282	15	12
6	T1089	13	5	16	T1161	15	13
7	T1090	13	6	17	T1274	15	14
8	T1091	13	7				

GEARBOX — GROUP 3

REF. No.	PART No.	DESCRIPTION	QUANTITY	
			T20	T20C
KICKSTARTER				
1	T1165	Kickstarter assembly, folding	1	1
2	T1166	Crank, kickstarter	1	1
3	T1168	Pedal, kickstarter crank	1	1
4	F1814	Rubber, kickstarter pedal	1	1
5	T1169	Bolt, kickstarter crank to pedal	1	1
6	S70-3	Ball, kickstarter crank to pedal	1	1
7	T1167	Spring, kickstarter crank to pedal	1	1
8	S52-1	Cotter, kickstarter crank c/w nut and washer	1	1
9	T1279	Spindle, kickstarter c/w bush	1	1
10	T1118	Bush, kickstarter spindle	1	1
11	T1281	Pawl, kickstarter... ..	1	1
12	T1282	Plunger, kickstarter pawl	1	1
13	T1161	Spring, kickstarter plunger	1	1
14	T1274	Disc, pawl retaining	1	1
15	T1162	Spring, kickstarter return	1	1
16	T1163	Plate, kickstarter return spring anchor	1	1
17	T1157	Plate, kickstarter stop	1	1
18	T1158	Screw, kickstarter stop plate	1	1
GEARBOX SPROCKET				
19	T1081	Sprocket, gearbox, 17 teeth	1	-
20	T1369	Sprocket, gearbox 16 teeth	-	1
SPECIAL NOTE. Subsequent to Engine No. 35847 use :				
21	T1513/18	Sprocket, gearbox 18 teeth	1	-
22	T1513/16	Sprocket, gearbox 16 teeth	-	1
23	T1082	Nut, gearbox sprocket	1	1
FILLER, LEVEL AND DRAIN PLUGS				
24	T1110	Plug, gearbox filler	1	1
25	E697	Washer, gearbox filler plug	1	1
26	T1112	Plug, gearbox drain	1	1
27	T1257	Washer, gearbox drain plug	1	1
28	T361	Plug, gearbox level	1	1
29	WE170	Washer, gearbox level plug	1	1
CLUTCH				
30	T1341	Clutch, complete ($\frac{1}{2}$ in. pitch chain)	1	1
31	T1119	Key, clutch to mainshaft	1	1
32	T1347	Tabwasher, clutch nut	1	1
33	T1348	Nut, clutch to mainshaft	1	1

GROUP 3 — GEARBOX

REF. No.	PART No	DESCRIPTION	QUANTITY	
			T20	T20C
1	T1343	Housing and sprocket (36 teeth)	1	1
2	T1124	Ball, clutch sprocket bearing	16	16
3	T1264	Bearing ring, clutch sprocket	1	1
4	T1345	Shock absorber assembly comprising lines 6 to 12	1	1
5	T1314	Clutch centre	1	1
6	T1128	Backplate	1	1
7	T1364	Cup, centre driving	3	3
8	T1350	Pin, driving cup	3	3
9	T1346	Spider	1	1
10	T1132	Rubber, drive	3	3
11	T1318	Rubber, rebound	3	3
12	T1315	Driven Plate	3	3
13	T1294	Driving plate complete with linings	3	3
14	T1253	Pressure plate	1	1
15	T1256	Adjuster, pressure plate	1	1
16	GS662	Nut, for adjuster	1	1
17	T1144	Cup pressure spring	3	3
18	T1145	Spring, clutch pressure	3	3
19	T1146	Nut, clutch pin	3	3

SPECIAL NOTE. Subsequent to Engine No. 35847 use :

20	T1493	Clutch complete ($\frac{3}{8}$ in. pitch duplex chain)	1	1
21	T1509	Housing and sprocket (48 teeth duplex)	1	1
22	T1503	Driving plate complete with linings	3	3

CLUTCH CONTROL

23	T1233	Lever, clutch operating assembly	1	1
24	T1235	Lever, clutch operating	1	1
25	T1236	Pin, operating lever fulcrum	1	1
26	T1155	Cup, operating lever thrust	1	1
27	T1124	Ball, cup to rod	1	1
28	$\frac{1}{16}'' \times \frac{1}{2}''$	Split-pin, cup to lever	1	1
29	T1234	Fulcrum, clutch operating lever	1	1
30	T1140	Rod, clutch operating	1	1

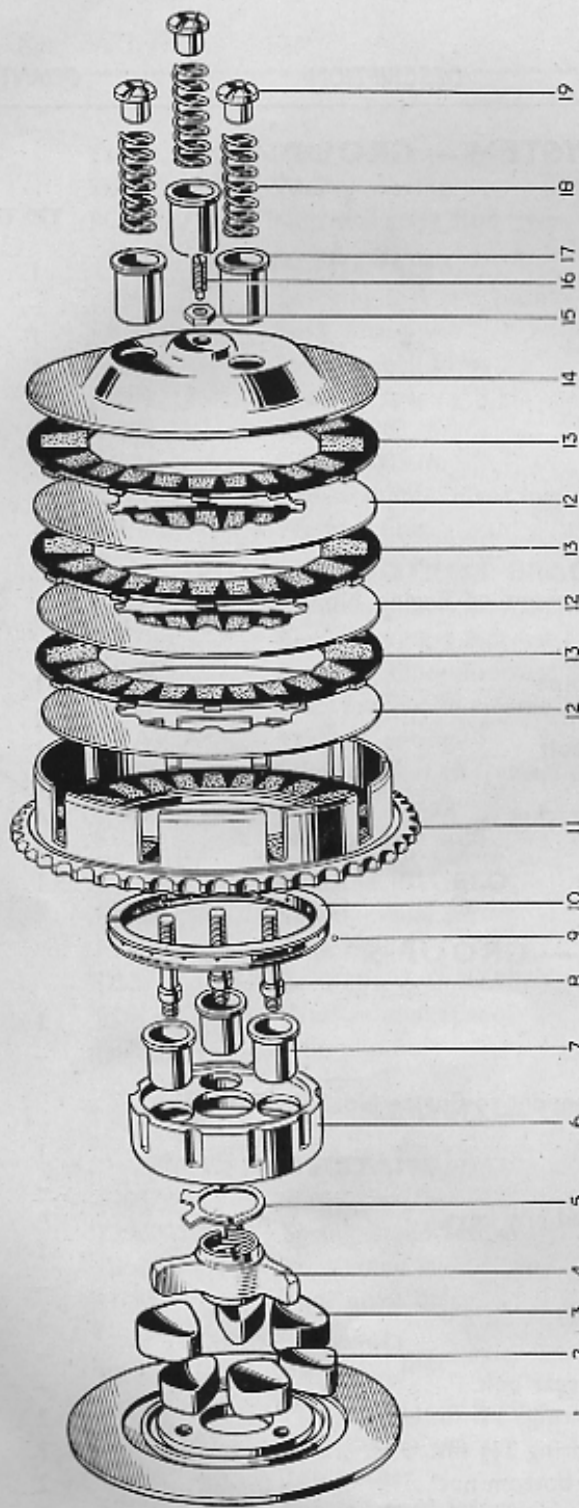

FIG. 3. CLUTCH AND SHOCK ABSORBER UNIT.

INDEX

Illust. No.	Part No.	Page No.	Ref. No.	Illust. No.	Part No.	Page No.	Ref. No.
1	T1128	16	6	11	T1343	16	1
2	T1132	16	10	12	T1509	16	21
3	T1318	16	11	13	T1315	16	12
4	T1346	16	9	14	T1294	16	13
5	T1347	15	32	15	T1503	16	22
6	T1314	16	5	16	T1253	16	14
7	T1364	16	7	17	GS662	16	16
8	T1350	16	8	18	T1256	16	15
9	T1124	16	2	19	T1144	16	17
10	T1264	16	3		T1145	16	18
					T1146	16	19

GROUP 4 — EXHAUST SYSTEM**GROUP 5 — FRAME**

REF. No.	PART No.	DESCRIPTION	QUANTITY
----------	----------	-------------	----------

EXHAUST SYSTEM — GROUP 4**EXHAUST PIPE**

T20 T20C

1	E3257	Pipe, exhaust	1	-
2	E3883	Pipe, exhaust	-	1
3	E3259	Clip, pipe to head	1	1
4	E3260	Bolt, pipe clip	1	1
5	S25-13	Washer, clip bolt	1	1

SILENCER

6	E3637	Silencer	1	-
7	E3840	Silencer	-	1

SPECIAL NOTE. Subsequent to Engine No. 35847 use :

8	E3928	Silencer	1	-
9	E3269	Clip, silencer to pipe	1	1
10	TE164E	Bolt, silencer clip	1	1
11	TE164D	'D' Washer, clip bolt	1	1
12	TE164C	'D' Nut, clip bolt	1	1
13	F929	Bolt, silencer to bracket... ..	A	1
14	S26-1	Washer, spring	1	1
15	PO172A	Nut, silencer bolt	1	1

FRAME — GROUP 5

16	F4050	Frame, front	1	-
17	F4252	Frame, front	-	1

SPECIAL NOTE. Subsequent to Engine No. 35847 use :

18	F4418	Frame, front	1	-
19	F4420	Frame, front	-	1
20	D402/3	Lock, steering head c/w keys	A	A
21	F4051	Frame, rear	1	-
22	F4253	Frame, rear	-	1
23	F3929	Collar, engine bolts	2	-
24	E3843	Collar, engine bolts	-	2
25	S25-2	Distance washer, rear bolt	-	1
26	F3953	Bolt, engine mountings $1\frac{1}{8}$ in. U.H.	2	2
27	F3954	Bolt, engine mounting $2\frac{1}{8}$ ins. U.H.	1	1
28	S25-2	Washer, rear and bottom nut	2	2
29	F3955	Nut, engine bolts	3	3

FRAME — GROUP 5
STAND — GROUP 6

REF. No.	PART No.	DESCRIPTION	QUANTITY	
			T20	T20C
1	E1023	Stud, seat stays $3\frac{3}{16}$ ins. O.A.	1	1
2	S26-1	Washer, spring	2	2
3	PO172A	Nut, seal stays stud	2	2
SWINGING FORK				
4	F4068	Swinging fork c/w bushes	1	1
5	F4076	Bush, fork pivot	2	2
6	F4079	Spindle, fork pivot	1	1
7	F4079 F4078	Washer, spacing R.H.	1	1
8	F4385	Shim, 0.003 in.	as necessary	
9	F4386	Shim, 0.005 in.	as necessary	
10	KW194	Grease nipple, pivot lug	1	1
11	WE170	Washer, fibre	1	1
PILLION FOOTREST BRACKETS				
12	F4080	Bracket, pillion footrest L.H.	1	-
13	F4278	Bracket, pillion footrest L.H.	-	1
14	F4081	Bracket, pillion footrest R.H.	1	1
15	F4087	Bolt, bracket to spindle $1\frac{1}{2}$ in. U.H.	2	2
16	PCW73A	Washer, spring	2	2
17	E1396	Stud, bracket to frame $1\frac{1}{16}$ in. O.A.	2	2
18	S26-3	Washer, spring	2	2
19	S1-51	Nut, bracket stud	2	2
CRANKCASE SHIELD				
20	F4258	Shield, crankcase	-	1
21	F4260	Clip, shield	-	1
22	DS57	Bolt, clip $\frac{7}{16}$ in. U.H.	-	2
23	E1612	Washer, shakeproof	-	2
24	F879	Nut, clip bolt	-	2
STAND — GROUP 6				
CENTRE STAND				
25	F3957	Stand, centre	1	-
26	F3960	Spring, stand return	1	-
27	F3520	Bolt, stand pivot	2	-
28	H193	Nut, pivot bolt	2	-
PROP STAND				
29	F3681	Prop stand, c/w fittings	1	-
30	F4277	Prop stand, c/w fittings	-	1
31	F3097	Pin, stand pivot	1	1
32	F3096	Tab washer	1	1
33	F2610	Spring, stand return	1	1

GROUP 5 — FRAME

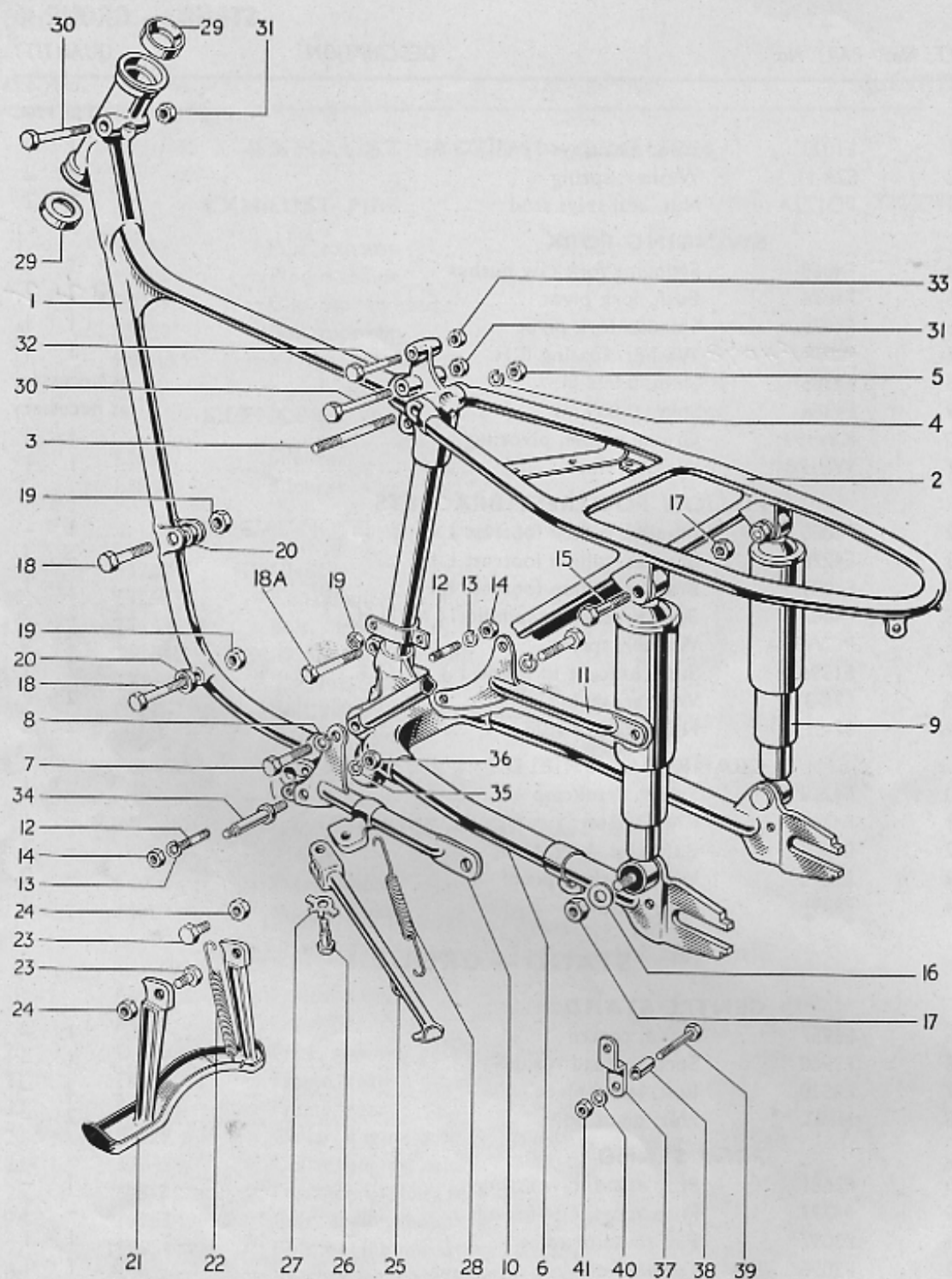

FIG. 4. FRAME AND COMPONENTS.

For [Index, See Page 21.

FRAME — GROUP 5

INDEX TO FIG. 4

Illust. No.	Part No.	Page No.	Ref. No.
1	See page 18		
2	F4051	18	21
	F4253	18	22
3	E1023	19	1
4	S26-1	19	2
5	PO172A	19	3
6	F4068	19	4
7	F4087	19	15
8	PCW73A	19	16
9	See page 53		
10	F4080	19	12
	F4278	19	13
11	F4081	19	14
12	E1396	19	17
13	S26-3	19	18
14	S1-51	19	19
15	F1760	53	22
16	S25-2	53	23
17	PO172A	53	24
18	F3953	18	26
18A	F3954	18	27
19	F3955	18	29
20	F3929	18	23
	E3843	18	24
21	F3957	19	25
22	F3960	19	26
23	F3520	19	27
24	H193	19	28
25	F3681	19	29
	F4277	19	30
26	F3097	19	31
27	F3096	19	32
28	F2610	19	33
29	H835	27	29
30	F3498	39	11
31	S1-51	39	13
32	E667A	53	3
33	S1-51	53	5
34	F4090	42	2
35	S26-1	42	4
36	PO172A	42	3
37	F4311	53	25
38	F3207	53	27
39	H622	53	26
40	E1330C	53	28
41	S1-51	53	29

GROUP 7 — TELESCOPIC FRONT FORK

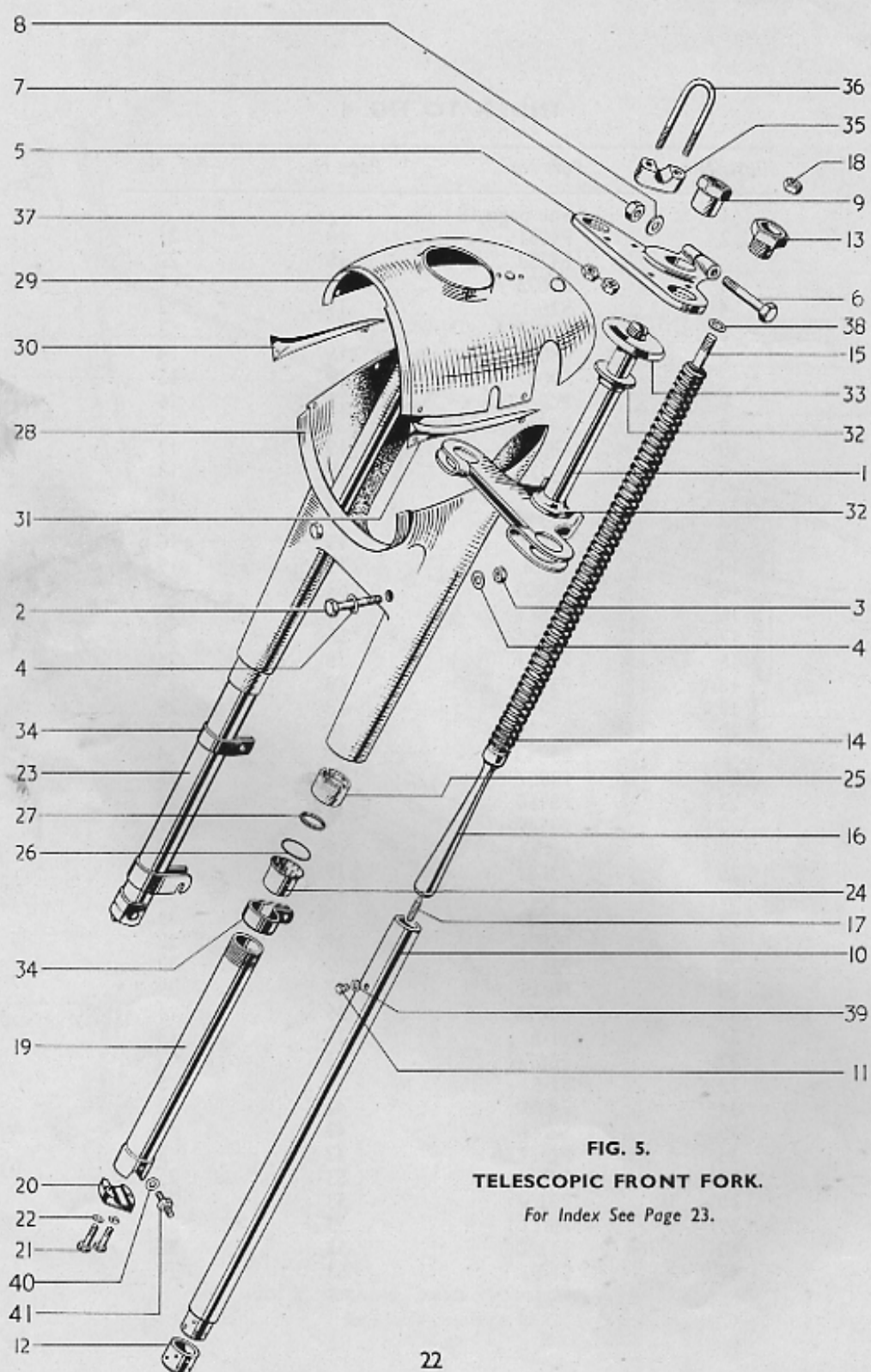

FIG. 5.
TELESCOPIC FRONT FORK.

For Index See Page 23.

TELESCOPIC FRONT FORK — GROUP 7

INDEX TO FIG. 5. PAGE 22.

<i>Illust. No.</i>	<i>Part No.</i>	<i>Page No.</i>	<i>Ref. No.</i>
1	H1231	26	4
2	H834	26	6
3	H518	26	9
4	S25-3	26	7
5	H837	26	10
6	H570	26	12
7	S1-51	26	13
8	S25-3	26	14
9	H840	26	15
10	H1035	26	17
11	H519A	26	19
12	H845	26	21
13	H846	26	22
14	H1037	26	23
15	H850	26	25
16	H1047	26	29
17	H1048	26	30
18	S1-51	26	27
19	H1040	26	31
20	H856	27	5
21	W932	27	7
22	E1612	27	6
23	H1043	27	1
24	H1046	27	8
25	H1045	27	10
26	H862	27	9
27	H1044	27	12
28	H823	27	15
29	H822	27	19
30	H878	27	21
31	H877	27	20
32	H833	27	31
33	H836	27	33
34	H873	33	13
35	H864	42	17
36	H865	42	18
37	F879	42	19
38	E2287	26	28
39	H430	26	20
40	WE170	27	4
41	H1042	27	3

GROUP 7 — TELESCOPIC FRONT FORK

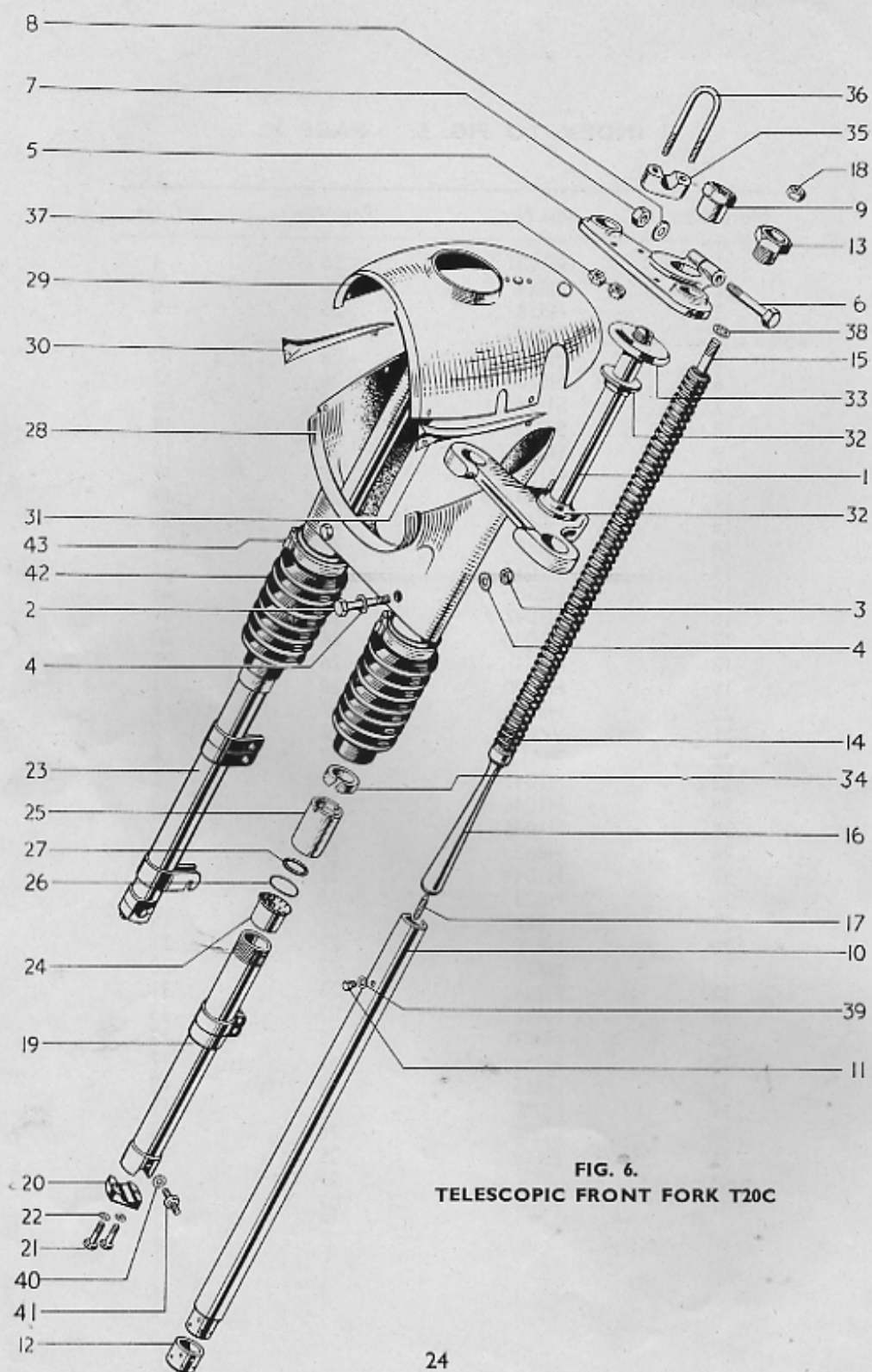

FIG. 6.
TELESCOPIC FRONT FORK T20C

TELESCOPIC FRONT FORK — GROUP 7

INDEX FIG. 6

<i>Illust. No.</i>	<i>Part No.</i>	<i>Page No.</i>	<i>Ref. No.</i>
1	H1233	26	5
2	H834	26	6
3	H518	26	9
4	S25-3	26	7
5	H1133	26	11
6	H570	26	12
7	SI-51	26	13
8	S25-3	26	14
9	H1137	26	16
10	H1190	26	18
11	H519A	26	19
12	H845	26	21
13	H846	26	22
14	H1191	26	24
15	H1153	26	26
16	H1047	26	29
17	H1048	26	30
18	SI-51	26	27
19	H1149	26	32
20	H856	27	5
21	W932	27	7
22	E1612	27	6
23	H1150	27	2
24	H1046	27	8
25	H1151	27	11
26	H862	27	9
27	H1044	27	12
28	H824	27	16
29	H822	27	19
30	H878	27	21
31	H877	27	20
32	H833	27	31
33	H836	27	33
34	H1152	27	14
35	H864	42	17
36	H865	42	18
37	F879	42	19
38	E2287	26	28
39	H430	26	20
40	WE170	27	4
41	H1042	27	3
42	H1222	27	17
43	D404	27	18

GROUP 7 – TELESCOPIC FRONT FORK

REF. No.	PART No.	DESCRIPTION	QUANTITY	
			T20	T20C
1	H1230	Fork assembly	1	-
2	H1173	Fork assembly	-	1
SPECIAL NOTE. Subsequent to Engine No. 35847 use :				
3	H1232	Fork assembly	-	1
4	H1231	Middle lug and stem	1	-
5	H1233	Middle lug and stem	-	1
6	H834	Bolt, middle lug pinch	2	2
7	S25-3	Washer, bolt and nut	4	4
8	F3098	Clip, brake cable... ..	1	1
9	H518	Nut, pinch bolt	2	2
10	H837	Lug, fork top	1	-
11	H1133	Lug, fork top	-	1
12	H570	Bolt, top lug pinch	1	1
13	SI-51	Nut, pinch bolt	1	1
14	S25-3	Washer, pinch bolt	1	1
15	H840	Sleeve nut, fork stem	1	-
16	H1137	Sleeve nut, fork stem	-	1
17	H1035	Stanchion, c/w bush	2	-
18	H1190	Stanchion, c/w bush	-	2
19	H519A	Plug, oil filler $\frac{3}{16}$ in. U.H.	2	2
20	H430	Washer, fibre	2	2
21	H845	Bush, stanchion bottom	2	2
22	H846	Nut, stanchion to top lug	2	2
23	H1037	Spring, c/w restrictor rod and stud	2	-
24	H1191	Spring, c/w restrictor rod and stud	-	2
25	H850	Stud, top $1\frac{9}{16}$ in. O.A.	2	-
26	H1153	Stud, top $2\frac{9}{16}$ ins. O.A.	-	2
27	SI-51	Nut, top stud	2	2
28	E2287	Washer, shakeproof	2	2
29	H1047	Rod, restrictor	2	2
30	H1048	Stud, restrictor rod $1\frac{7}{8}$ in. in O.A.	2	2
31	H1040	Member, outer, c/w cap L.H.	1	-
32	H1149	Member, outer, c/w cap L.H.	-	1

TELESCOPIC FRONT FORK – GROUP 7

REF. No.	PART No.	DESCRIPTION	QUANTITY	
			T20	T20C
1	H1043	Member, outer, c/w cap R.H.	1	-
2	H1150	Member, outer, c/w cap R.H.	-	1
3	H1042	Stud, oil drain $\frac{3}{8}$ in. O.A.	2	2
4	WE170	Washer, fibre	2	2
5	H856	Cap, wheel spindle	2	2
6	E1612	Washer, shakeproof	4	4
7	W932	Bolt, spindle cap 1 in. U.H.	4	4
8	H1046	Bush, fork top	2	2
9	H862	Washer, sleeve nut, steel	2	2
10	H1045	Sleeve nut, dust excluder	2	-
11	H1151	Sleeve nut, dust excluder	-	2
12	H1044	Oil seal, rubber	2	2
13	H1221	Shim, oil seal (prior to Engine No. 34214)	when necessary	
14	H1152	Washer, felt	-	2
15	H823	Nacelle, bottom unit	1	-
16	H824	Nacelle, bottom unit	-	1
17	H1222	Gaiter, telescopic	-	2
18	D404	Clip, gaiter	-	2
19	H822	Nacelle, top unit...	1	1
20	H877	Flash, L.H. (motif)	1	1
21	H878	Flash R.H. (motif)	1	1
22	H688	Screw, flash and top and bottom unit $\frac{5}{16}$ in. U.H.	2	2
23	H691	Nut, flash and top and bottom unit	2	2
24	E2880	Washer, flash and top and bottom unit	2	2
25	H916	Screw, flash and top and bottom unit (centre) $\frac{8}{32}$ in. U.H.	2	2
26	H689	Screw, top and bottom unit (rear) $\frac{1}{2}$ in. U.H.	2	2
27	H691	Nut, top and bottom unit (rear)	2	2
28	E2880	Washer, top and bottom unit (rear)	2	2
29	H961	Grommet, control cables	3	3

STEERING RACES

30	H835	Cup, steering race (top and bottom)	2	2
31	H833	Cone, steering race (top and bottom)	2	2
32	S70-3	Ball, steering race (top and bottom)	30	30
33	H836	Cover, steering race, dust	1	1

GROUP 8 - WHEELS

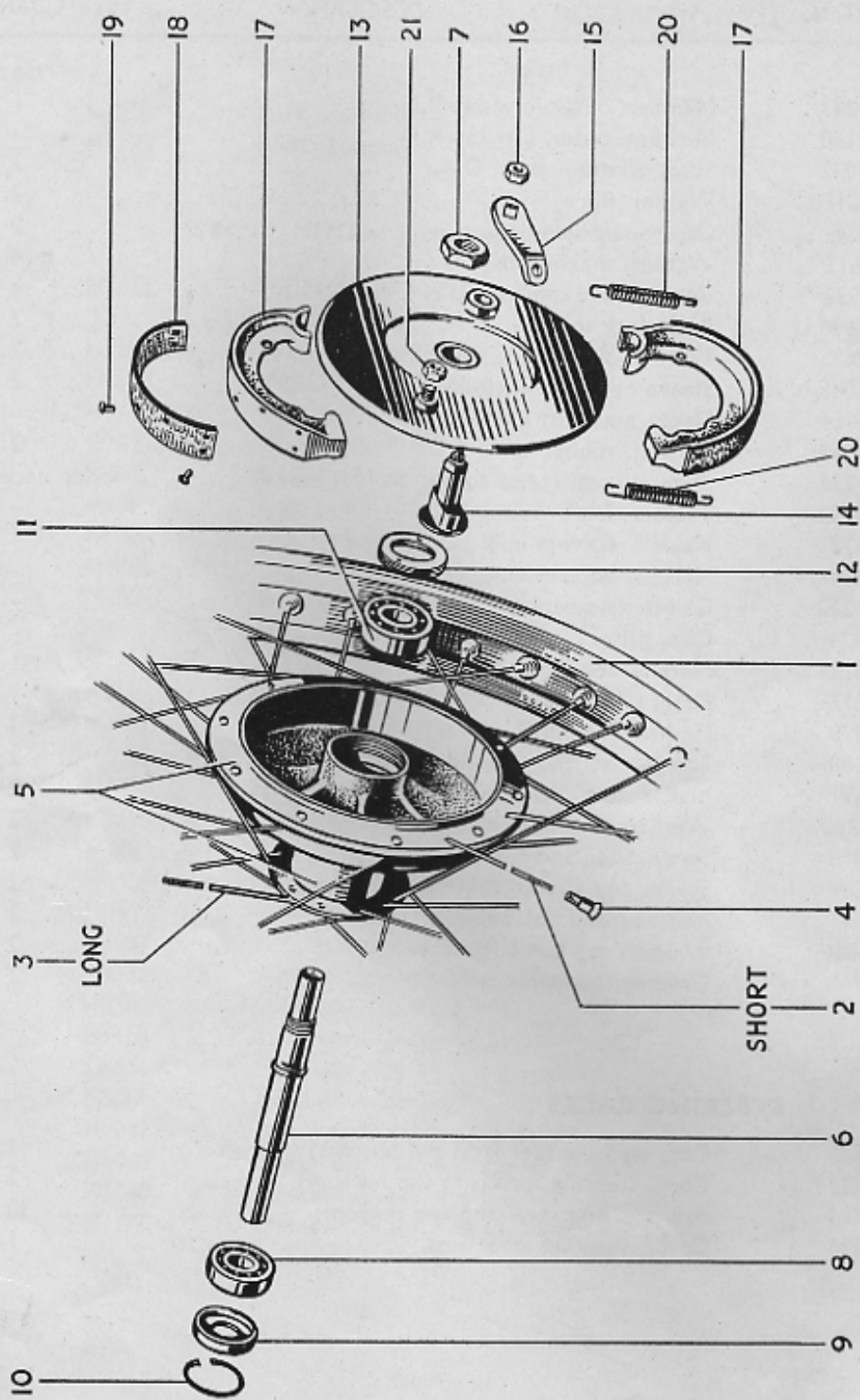
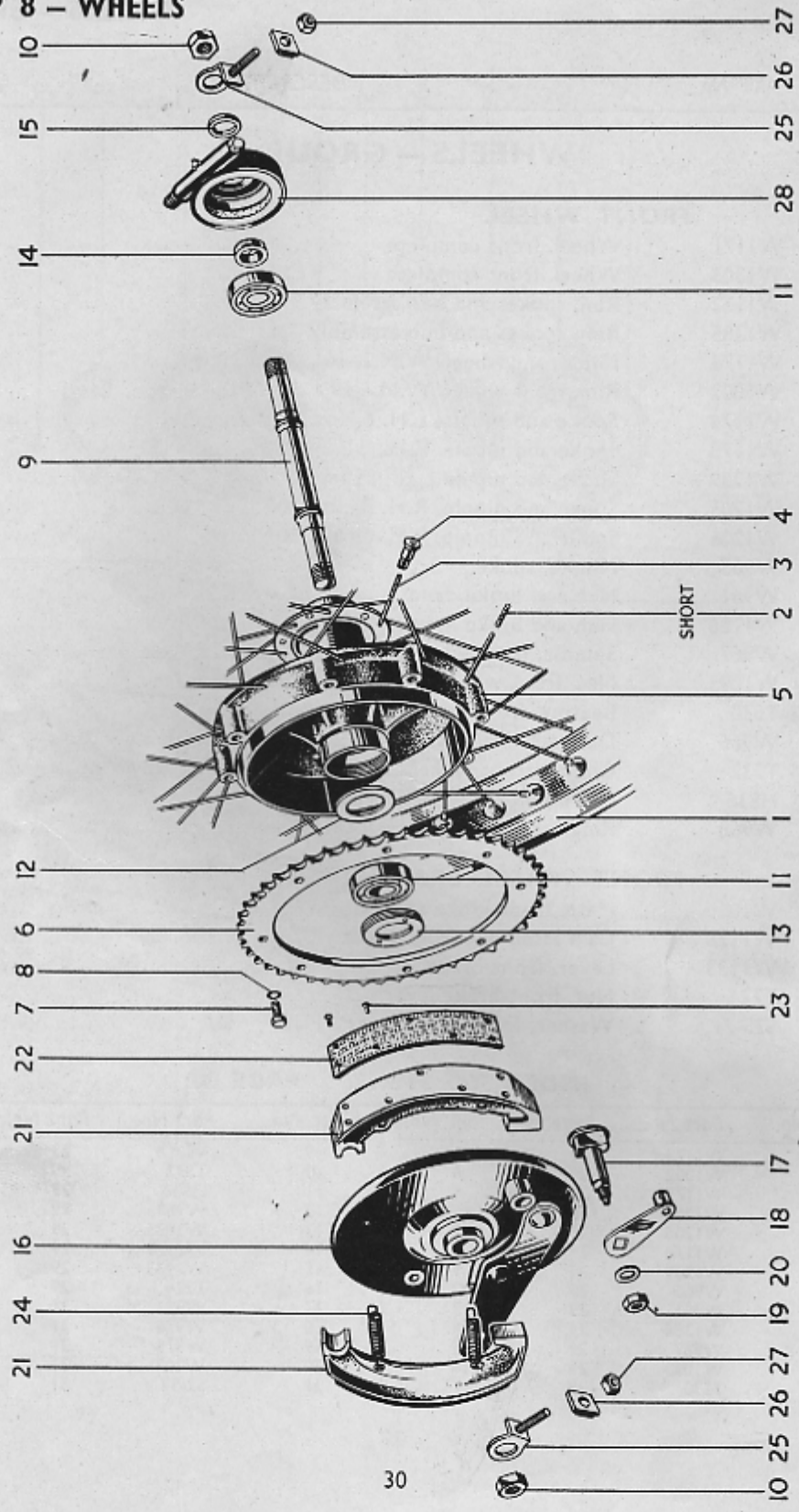

FIG. 7. FRONT WHEEL.

For Index See Page 29.

GROUP 8 - WHEELS



WHEELS - GROUP 8

REF. No.	PART No.	DESCRIPTION	QUANTITY	
			T20	T20C
1	W977	Shoe, front brake c/w lining	2	2
2	W978	Lining, front brake	2	2
3	W979	Rivet, front brake lining	12	12
4	W200	Spring, front brake shoe	2	2
5	SI-52	Nut, front brake anchorage to clip	1	1
6	S26-1	Washer, front brake anchorage to clip	1	1

REAR WHEEL

7	*W1217	Wheel, rear, complete	1	-
8	*W1304	Wheel, rear, complete	-	1
9	W1256	Rim, spokes and hub assembly	1	-
10	W1290	Rim, spokes and hub assembly	-	1
11	W1173	Rim, rear wheel W.M.2-16	1	-
12	W1296	Rim, rear wheel W.M.2-19	-	1
13	W1213	Spoke and nipple L.H. $5\frac{15}{16}$ ins. 100°	10	-
14	W1214	Spoke and nipple L.H. $5\frac{15}{16}$ ins. 80°	10	-
15	W1259	Spoke and nipple R.H. $6\frac{1}{8}$ ins. 90°	20	-
16	W1294	Spoke and nipple L.H. $6\frac{1}{8}$ ins. 100°	-	10
17	W1295	Spoke and nipple L.H. $6\frac{1}{8}$ ins. 80°	-	10
18	W1293	Spoke and nipple R.H. 8 ins. 90°	-	20
19	W965	Nipple, spoke	40	40
20	W1257	Hub and brake drum	1	1
21	*W1076	Sprocket, 54 teeth	1	1

* SPECIAL NOTE. Subsequent to Engine No. 35847 use :

22	W1321	Wheel, rear, complete	1	-
23	W1335	Wheel, rear, complete	-	1
24	W1320	Sprocket, 46 teeth	1	1

INDEX TO FIG. 8. PAGE 28.

Illust. No.	Part No.	Page No.	Ref. No.	Illust. No.	Part No.	Page No.	Ref. No.
1	W1173	31	11	12	W987	32	5
	W1296	31	12	13	W988	32	6
2	W1213	31	13	14	W954	32	7
	W1214	31	14	15	W1223	32	8
	W1294	31	16	16	W1219	32	9
	W1295	31	17	17	W1128	32	10
3	W1259	31	15	18	W1221	32	11
	W1293	31	18	19	T224	32	12
4	W965	31	19	20	S25-71	32	13
5	W1257	31	20	21	W977	32	14
6	W1076	31	24	22	W978	32	15
	W1320	31	24	23	W979	32	16
7	W1322	32	1	24	W200	32	17
8	W1122	32	2	25	W1224	32	21
9	W989	32	8	26	W1227	32	22
10	W1000	32	24	27	F879	32	23
11	H826	32	4	28	D175	32	28

GROUP 8 - WHEELS

REF. No.	PART No.	DESCRIPTION	QUANTITY	
			T20	T20C
1	W1322	Bolt, sprocket to drum, $\frac{5}{16}$ in. U.H.	...	8
2	W1122	Washer, spring	...	8
3	W989	Spindle, rear wheel	...	1
4	H826	Bearing, rear wheel, L.H. and R.H.	...	2
5	W987	Backing ring, L.H. bearing	...	1
6	W988	Locking ring, L.H. bearing	...	1
7	W954	Distance piece, R.H. inner	...	1
8	W1223	Distance piece, R.H. outer	...	1

REAR WHEEL BRAKE

9	W1219	Plate, brake anchor	...	1
10	W1128	Cam, brake	...	1
11	W1221	Lever, rear brake	...	1
12	T224	Nut, brake lever	...	1
13	S25-71	Washer, plain	...	1
14	W977	Shoe, brake c/w lining	...	2
15	W978	Lining, brake	...	2
16	W979	Rivet, brake lining	...	12
17	W200	Spring, shoe return	...	2
18	H211	Bolt, brake anchor, $\frac{1}{8}$ in. U.H.	...	1
19	F2184	Washer, plain	...	1
20	F3955	Nut, anchor bolt	...	1

REAR CHAIN ADJUSTER

21	W1224	Adjuster, rear chain	...	2
22	W1227	End plate, adjuster	...	2
23	F879	Nut, adjuster	...	2
24	W1000	Nut, wheel spindle	...	2

MUDGUARDS — GROUP 9

REF. No.	PART No.	DESCRIPTION	QUANTITY
----------	----------	-------------	----------

MUDGUARDS — GROUP 9

FRONT MUDGUARD

			T20	T20C
1	H929	Mudguard, front	1	-
2	H1156	Mudguard, front	-	1
3	H871	Stay, mudguard, L.H.	1	-
4	H872	Stay, mudguard, R.H.	1	-
5	H1157	Stay assembly	-	1
6	H1161	Bridge, mudguard support	-	1
7	DS57	Bolt, mudguard stay, $\frac{7}{16}$ in. U.H.	4	6
8	E1612	Washer, shakeproof	4	-
9	S25-1	Washer, plain	-	6
10	F879	Nut, mudguard	4	6
11	F879	Nut, stay to fork lug	2	2
12	E1612	Washer, shakeproof	2	2
13	H873	Clip, bridge to fork leg	2	-
14	GS218	Bolt, clip and bridge $\frac{3}{16}$ in. U.H.	2	4
15	E1612	Washer, shakeproof	2	4
16	F879	Nut	2	4

LICENCE HOLDER

17	D261	Licence holder	1	1
----	------	----------------	---	---

REAR MUDGUARD

18	F4094	Mudguard, rear	1	-
----	-------	----------------	---	---

SPECIAL NOTE. Subsequent to Engine No. 35847 use :

19	F4391	Mudguard, rear	1	-
20	F4270	Mudguard, rear	-	1
21	F4097	Stay, guard to frame front	2	-
22	F4262	Stay, guard to frame front	-	2
23	DS57	Bolt, guard to stay and frame, $\frac{7}{16}$ in. U.H.	4	4
24	S25-1	Washer, plain	4	4
25	F879	Nut, guard bolts	4	4
26	DS55	Bolt, stay to bracket $\frac{13}{16}$ in. U.H.	1	1
27	S26-3	Washer, spring	1	1
28	S1-51	Nut, bracket bolt	1	1
29	PF204	Clip, centre	1	1
30	F444	Backing plate	1	1
31	S25-1	Washer, plain	2	2
32	S23-42	Bolt, centre clip	2	2
33	E3203	Grommet, wiring harness	2	2

GROUP 9 - MUDGUARDS

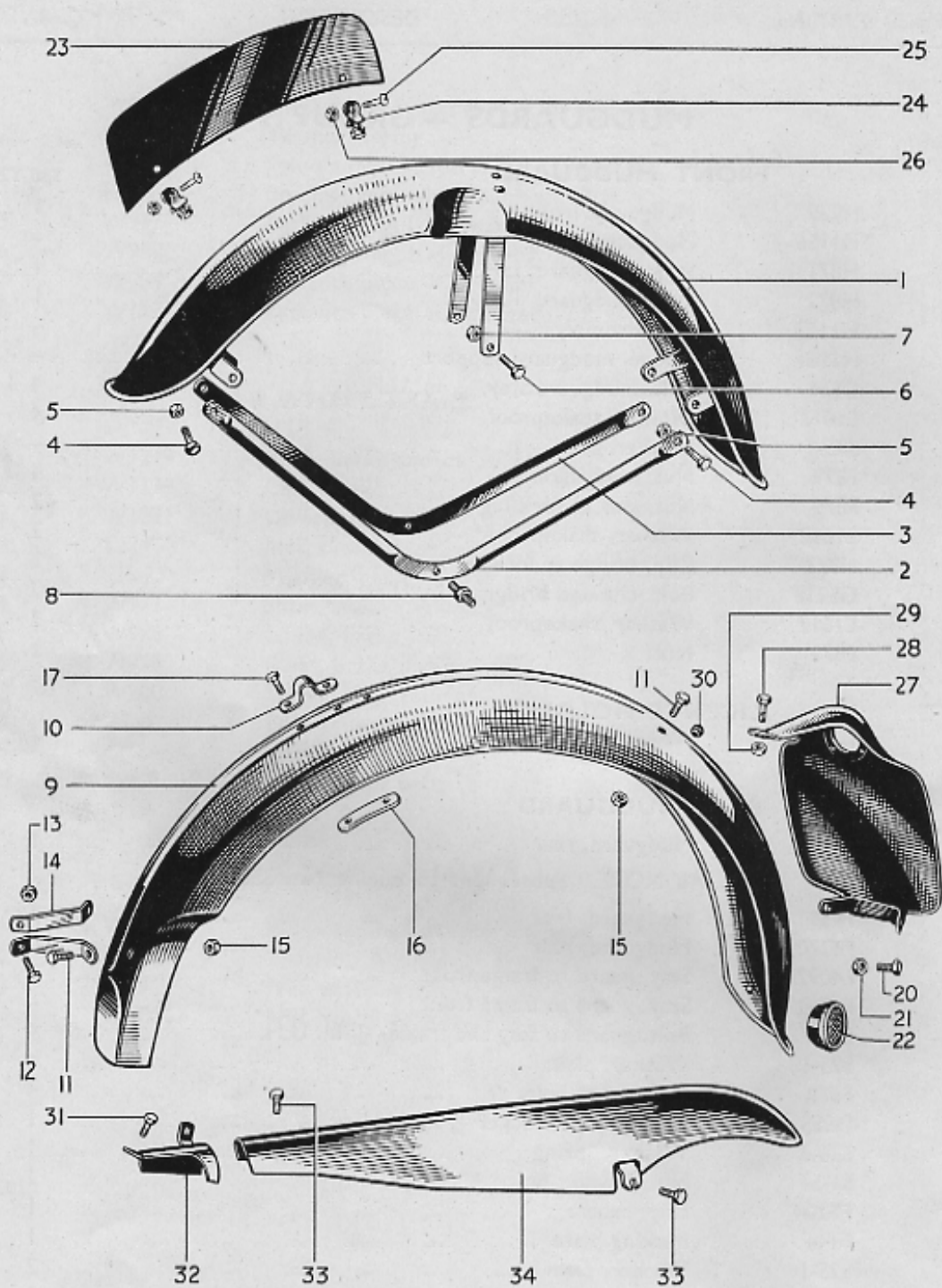

FIG. 9. MUDGUARDS, NUMBER PLATES AND REAR CHAINGUARD.
For Index See Page 35.

NUMBER PLATES — GROUP 10

REF. No. PART No. DESCRIPTION QUANTITY

NUMBER PLATES — GROUP 10

FRONT NUMBER PLATE

T20 T20C

1	H874	Plate, front number	1	—
2	F2996	Plate, front number	—	1
3	H741	Clip, assembly, front number plate	2	2
4	H687	Screw, front number plate to clip	2	2
5	H745	Nut, clip screw	2	2

REAR NUMBER PLATE

6	F3508	Plate, rear number	1	1
7	F929	Bolt, number plate top $\frac{1}{2}$ in. U.H.	1	1
8	SI-51	Nut, top bolt	1	1
9	S26-3	Washer, top bolt	1	1
10	F1369	Bolt, number plate bottom $\frac{3}{8}$ in. U.H.	2	2
11	F879	Nut, bottom bolt	2	2
12	S26-2	Washer, bottom bolt	2	2
13	D68	Transfer, number plate motif	1	1
14	57080	Reflector, c/w nut and washer	1	1

INDEX TO FIG. 9. PAGE 34.

Illust. No.	Part No.	Page No.	Ref. No.	Illust. No.	Part No.	Page No.	Ref. No.
1	H929	33	1	17	S23-42	33	32
2	H871	33	3	20	F1369	35	10
3	H872	33	4	21	F879	35	11
4	DS57	33	7	22	57080	35	14
5	F879	33	10	23	H874	35	1
6	GS218	33	14		F2996	35	2
7	F879	33	16	24	H741	35	3
8	H1042	27	3	25	H687	35	4
9	F4094	33	18	26	H745	35	5
	F4391	33	19	27	F3508	35	6
	F4270	33	20	28	F929	35	7
10	PF204	33	29	29	SI-51	35	8
11	DS57	33	23	30	E3203	33	33
12	DS55	33	26	31	DS57	36	12
13	SI-51	33	28	32	F4152	36	11
14	F4097	33	21	33	DS57	36	3
	F4262	33	22	34	F4089	36	1
15	F879	33	25		F4269	36	2
16	F444	33	30				

GROUP 11 – REAR CHAINGUARD**GROUP 12 – TOOLBOX, BATTERY CARRIER AND AIR CLEANER**

REF. No.	PART No.	DESCRIPTION	QUANTITY
----------	----------	-------------	----------

REAR CHAINGUARD – GROUP 11

			T20	T20C
1	F4089	Chainguard, rear... ..	1	-
2	F4269	Chainguard, rear... ..	-	1
3	DS57	Bolt, front and rear	2	2
4	S26-2	Washer, spring (front)	1	1
5	S25-1	Washer, plain (rear)	1	1
6	F4265	Clip, to swinging fork	-	1
7	E2818	Bolt, clip $1\frac{5}{8}$ in. U.H.	-	1
8	F4263	Distance piece	-	1
9	E1612	Washer, shakeproof	-	1
10	F879	Nut, clip bolt	-	1
11	F4152	Chainguard, front portion	1	1
12	DS57	Bolt, to crankcase $\frac{7}{8}$ in. U.H.	1	1
13	S25-13	Washer, plain	1	1
14	S26-2	Washer, spring	1	1

TOOLBOX, BATTERY CARRIER AND AIR CLEANER**GROUP 12**

15	F3491	Toolbox, battery and air cleaner assembly casing	-	1
16	F3470	Pad, battery, rubber moulded	2	2
17	F3418	Container, air cleaner	1	1
18	H251	Beading, air cleaner container, rubber... ..	1	1
19	F3492	Element, air cleaner	1	1
20	F3656	Stud, air cleaner to case	1	1
21	H745	Nut, air cleaner to case	1	1
22	F3473	Strap, battery case	1	1
23	F3472	Hook-bolt, battery case strap and lid	1	1
24	F879	Nut, battery case hook bolt	1	1
25	F3493	Lid, casing c/w knob	1	1
26	F3474	Knob, casing lid	1	1
27	F3475	Circlip, casing lid knob	1	1
28	F3478	Connector, air cleaner to carburetter	1	1
29	E3203	Grommet, oil tank vent	1	1
30	199002	Grommet, wiring harness	1	1

TOOLS – GROUP 13

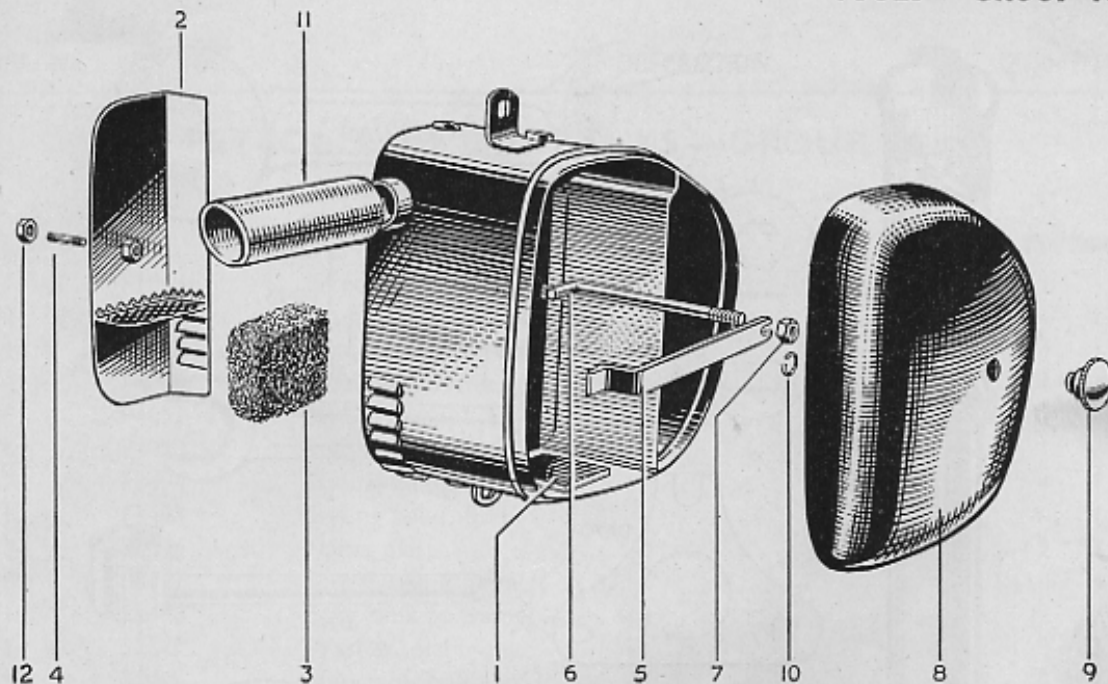

FIG. 10. TOOLBOX, BATTERY CARRIER AND AIR CLEANER.

INDEX TO FIG. 10

Illust. No.	Part No.	Page No.	Ref. No.	Illust. No.	Part No.	Page No.	Ref. No.
1	F3470	36	16	7	F879	36	24
2	F3418	36	17	8	F3493	36	25
3	F3492	36	19	9	F3474	36	26
4	F3656	36	20	10	F3475	36	27
5	F3473	36	22	11	F3478	36	28
6	F3472	36	23	12	H745	36	21

TOOLS – GROUP 13

Illustrated on page 38

REF. No.	PART No.	DESCRIPTION	QUANTITY	
			T20	T20C
1	D290	Tool kit, complete		
2	D291	Toolbag		
3	D299	Spanner, open ended, $\frac{3}{8}$ " \times $\frac{7}{16}$ " Whit.		
4	D292	Spanner, open ended, $\frac{1}{8}$ " \times $\frac{3}{16}$ " \times $\frac{1}{4}$ " \times $\frac{5}{16}$ " Whit.		
5	D293	Spanner, combination square \times $\frac{3}{16}$ " \times $\frac{5}{16}$ " \times $\frac{1}{2}$ " Whit.		
6	D294	Spanner, screwdriver and box, $\frac{1}{4}$ " Whit.		
7	DA70	Key, clutch adjusting		
8	NA14A	Lever, tyre		
9	D335	Screwdriver, Phillips No. 2		
10	D296	Inflator, tyre (not included in D290)		

GROUP 13 - TOOLS

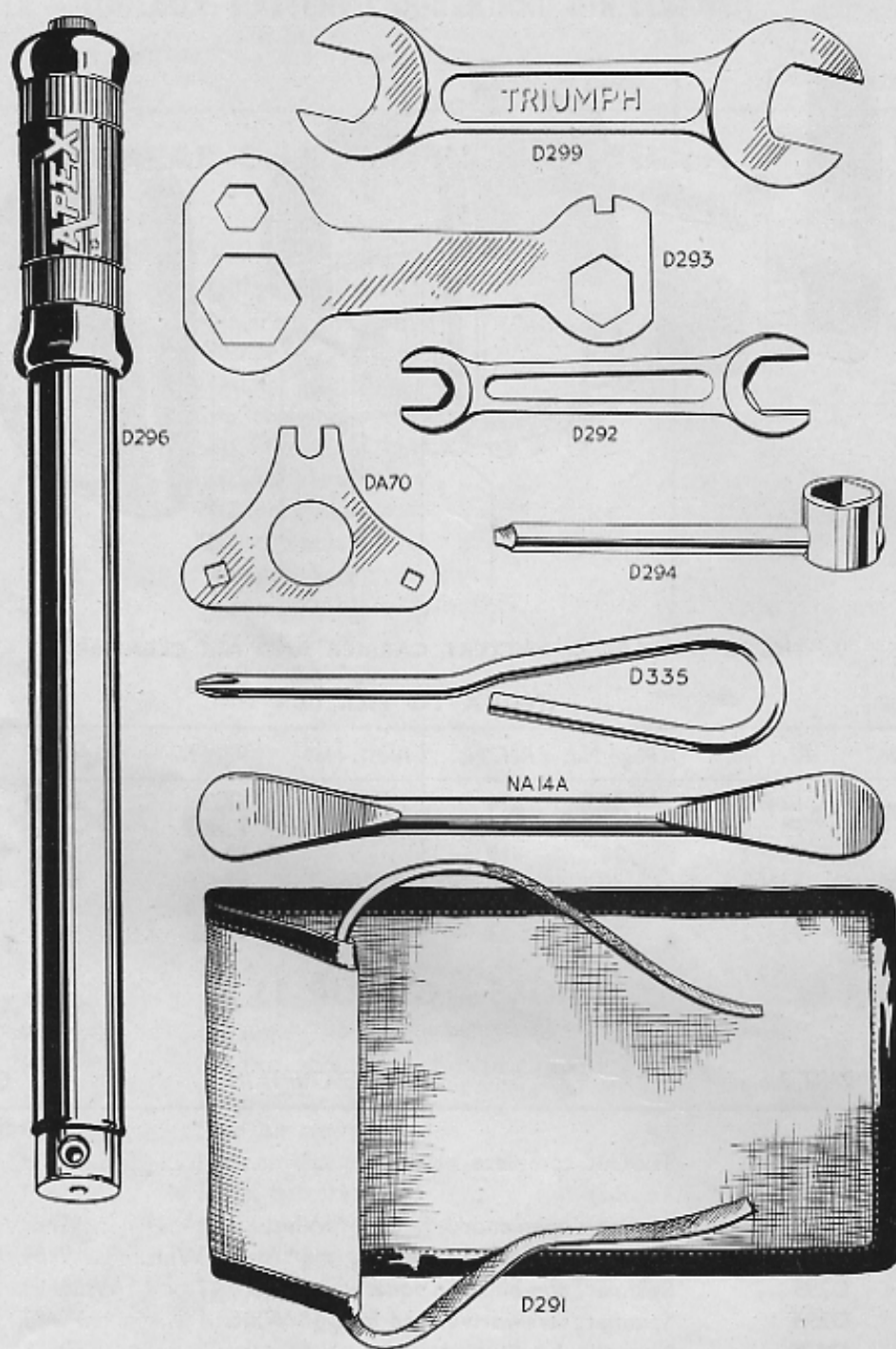

FIG. II. TOOLS.

PETROL AND OIL TANKS — GROUP 14

REF. No.	PART No.	DESCRIPTION	QUANTITY
----------	----------	-------------	----------

PETROL AND OIL TANKS — GROUP 14

See also page 64 Illustrated on page 40

		PETROL TANK	T20	T20C
1	F3963	Petrol tank, less fittings	1	-
2	F3505	Petrol tank, less fittings	-	1
3	F3220	Cap, filler c/w washer	1	1
4	F4048	Washer, filler cap	1	1
5	F4032	Styling band, L.H.	1	-
6	F4033	Styling band, R.H.	1	-
7	F3494	Styling band, L.H.	-	1
8	F3495	Styling band, R.H.	-	1
9	F3496	Name plate	2	2
10	F3497	Screw, name plate $\frac{11}{16}$ in. U.H.	4	4
11	F3498	Bolt, tank to frame, $2\frac{1}{8}$ in. U.H.	2	2
12	S25-3	Washer, plain	3	3
13	S1-51	Nut, tank bolt	2	2
14	F3506	Tap, petrol	1	1
15	E697	Washer, fibre	1	1
16	F3499	Pipe, petrol feed	1	1
17	F1605	Knee grip, R.H.	1	1
18	F1606	Knee grip, L.H.	1	1
OIL TANK				
19	F3464	Oil tank, less fittings	1	-
20	F4318	Oil tank, less fittings	-	1
21	F3216	Cap, filler c/w washer	1	1
22	F4047	Washer, filler cap	1	1
23	F1792	Drain plug, oil tank	1	1
24	PT104B	Washer, fibre	1	1

INDEX TO FIG. 12. PAGE 40.

Illust. No.	Part No.	Page No.	Ref. No.	Illust. No.	Part No.	Page No.	Ref. No.
1	F3963	39	1	12	F3464	39	19
	F3505	39	2		F4318	39	20
2	F3220	39	3	13	F3216	39	21
3	F4032	39	5	14	F3876	41	1
	F3494	39	7	15	F1511	41	2
4	F4033	39	6	16	E3270	41	9
	F3495	39	8	17	F3503	41	11
5	F3496	39	9	18	F3504	41	12
6	F3497	39	10	19	F3077	41	10
7	F3506	39	14	20	E3244	7	16
8	E697	39	15	21	E3383	7	20
9	F3499	39	16	22	F1792	39	23
10	F1605	39	17	23	PT104B	39	24
11	F1606	39	18				

GROUP 14 – PETROL AND OIL TANKS

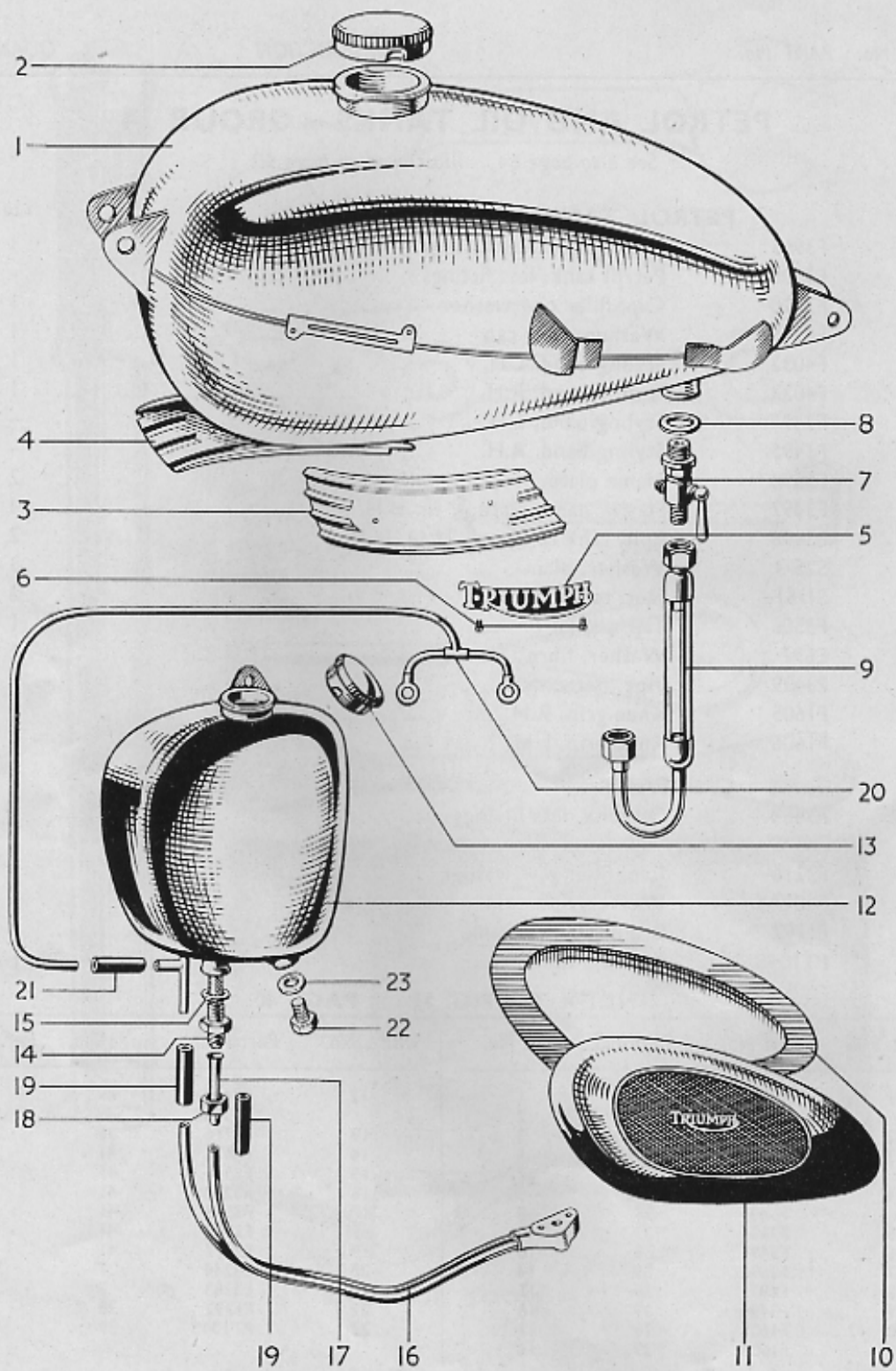

FIG. 12. PETROL AND OIL TANKS.
For Index See Page 39.

PETROL AND OIL TANKS – GROUP 14

FOOTRESTS – GROUP 15

REF. No.	PART No.	DESCRIPTION	QUANTITY	
			T20	T20C
1	F3876	Filter, oil tank	1	1
2	F1511	Washer, fibre	1	1
3	F2596	Bolt, tank to frame bottom, 1 $\frac{3}{8}$ in. U.H.	1	1
4	F3477	Distance piece, bottom	1	1
5	F3468	Bolt, tank to frame top 2 $\frac{1}{16}$ ins. U.H.	1	1
6	F3476	Distance piece, top	2	2
7	S1-51	Nut, tank bolts	2	2
8	S25-3	Washer, top bolt	1	1
9	E3270	Pipe assembly, tank to engine	1	1
10	F3077	Connection, rubber	2	2
11	F3503	Pipe, feed top half	1	1
12	F3504	Union nut, feed pipe	1	1
13	F3274	Joint washer, pipe to engine	1	1
14	F879	Nut, pipe to engine	1	1
15	S25-13	Washer, plain	1	1
16	A3	Transfer (Minimum Oil level)	1	1

FOOTRESTS – GROUP 15

17	F3449	Footrest L.H.	1	1
18	F3450	Footrest R.H.	1	1
19	F1695	Rubber	2	2
20	F3448	Rod, footrest hanger 6 $\frac{1}{2}$ in. O.A.	1	1
21	H193	Nut, footrest rod	2	2
SPECIAL NOTE. Subsequent to Engine No. 35847 use :				
22	F4383	Footrest, L.H.	1	1

PILLION FOOTREST

23	F4327	Footrest, pillion complete	2	2
24	F1694	Pedal, footrest	2	2
25	F1695	Rubber, footrest pedal	2	2
26	F2271	Bolt, footrest pedal pivot	2	2
27	S1-51	Nut, footrest pedal pivot bolt	2	2
28	F2277	Washer, footrest pedal pivot bolt	2	2
29	F2268	Hanger, footrest pedal	2	2
30	F4309	Stud, footrest pedal 1 $\frac{1}{8}$ in. O.A.	2	2
31	P0172A	Nut, footrest pedal stud	2	2
32	S26-1	Washer, footrest pedal stud	2	2

GROUP 16 – REAR BRAKE PEDAL**GROUP 17 – HANDLEBAR**

REF. No.	PART No.	DESCRIPTION	QUANTITY
----------	----------	-------------	----------

REAR BRAKE PEDAL – GROUP 16

T20 T20C

1	F4091	Pedal, rear brake	1	1
2	F4090	Spindle, brake pedal	1	1
3	PO172A	Nut, to frame	1	1
4	S26-1	Washer, spring	1	1
5	T224	Nut, pedal to spindle	1	1
6	S25-3	Washer plain	1	1
7	F4093	Rod, brake operating	1	1
8	F3461	Washer, pedal to rod	1	1
9	F3594	Washer, rod to pedal (for stop lamp)	A	A
10	$\frac{1}{16}$ in \times $\frac{1}{2}$ in.	Split pin, rod to pedal	1	1
11	F3463	Adjuster, brake rod	1	1

HANDLEBARS – GROUP 17*Illustrated on Page 43—Fig. 13*

12	70/510	Handlebar, c/w levers and twistgrip	1	–
13	H1192	Handlebar, c/w levers and twistgrip	–	1
14	91/322	Handlebar, c/w lever brackets	1	–
15	H934	Handlebar bend only	–	1
16	H881	Grommet, handlebar to nacelle	2	2
17	H864	Support, handlebar to top lug	2	2
18	H865	"U" bolt, handlebar	2	2
19	F879	Nut, "U" bolt	4	4
20	S25-13	Washer, plain	4	4
21	16/069	Grip, handlebar	1	1

CONTROL LEVERS

22	70/316	Lever, clutch control	1	–
23	70/317	Lever, front brake control	1	–
24	100/006	Screw, lever to bracket	2	–
25	70/016	Washer, Spring	2	–
26	18/717	Nut, lever screw	2	–
27	70/005	Stop, brake and clutch cable	2	–

HANDLEBAR – GROUP 17

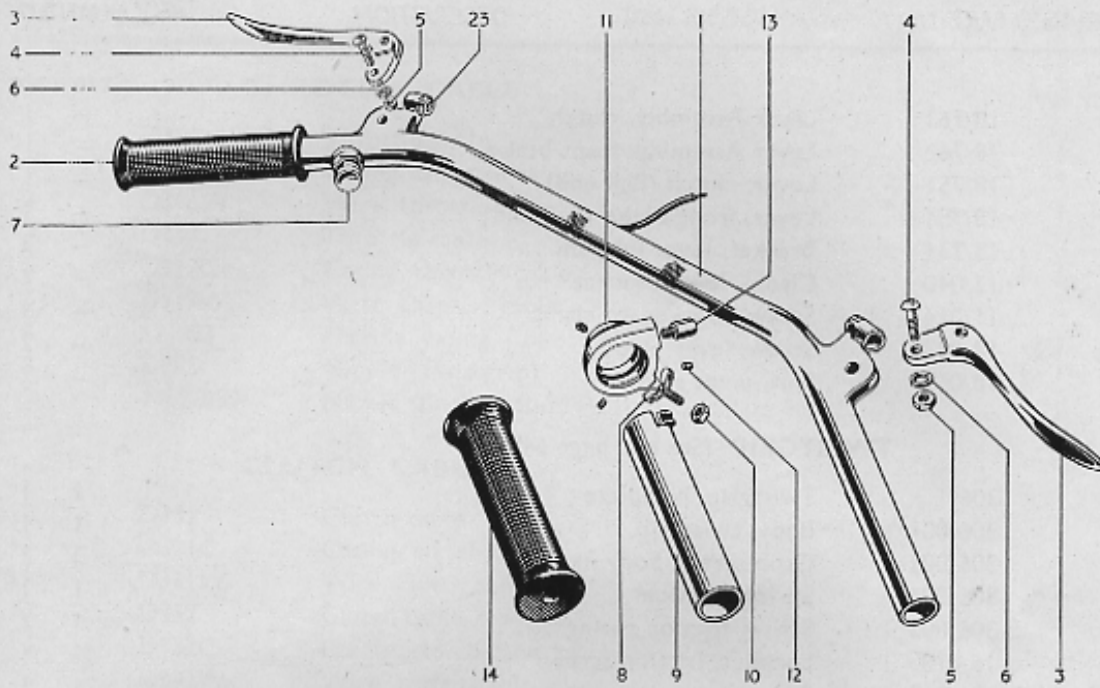

FIG. 13. HANDLEBAR AND COMPONENTS.

INDEX TO FIG. 13.

<i>Illust. No.</i>	<i>Part No.</i>	<i>Page No.</i>	<i>Ref. No.</i>	<i>Illust. No.</i>	<i>Part No.</i>	<i>Page No.</i>	<i>Ref. No.</i>
1	91/322	42	14	8	306/004	44	13
2	16/069	42	21	9	306/010	44	16
3	70/316	42	22	10	16/010	44	15
4	100/006	42	24	11	306/001	44	11
5	18/717	42	26	12	306/003	44	12
6	70/016	42	25	13	306/007	44	17
7	H886	49	33				

GROUP 17 – HANDLEBAR**GROUP 18 – CONTROL CABLES**

REF. No.	PART No.	DESCRIPTION	QUANTITY	
			T20	T20C
1	18/763	Lever Assembly, clutch	-	1
2	18/762	Lever Assembly, front brake	-	1
3	18/752	Lever, clutch (Ball end)	-	1
4	18/754	Lever, front brake (Ball end)	-	1
5	18/234	Bracket, lever fulcrum	-	2
6	12/040	Clamp, lever bracket	-	2
7	11/014	Screw, bracket, to clamp	-	4
8	18/087	Screw, lever pivot	-	2
9	18/053	Nut, pivot screw	-	2

TWISTGRIP (See also page 64)

10	306/1	Twistgrip, complete	1	1
11	306/001	Body, twistgrip	1	1
12	306/003	Grub screw, body fixing	3	3
13	306/004	Spring, friction	1	1
14	306/005	Screw, friction spring	1	1
15	16/010	Locknut, friction screw	1	1
16	306/010	Rotor, twistgrip	1	1
17	306/007	Cable stop	1	1
18	16/070	Grip, rubber	1	1

CONTROL CABLES GROUP 18**FRONT BRAKE CABLE**

19	D323	Cable assembly, front brake	1	-
20	D323C	Casing, front brake cable	1	-
21	D323W	Wire, front brake cable	1	-
22	D321	Cable assembly, clutch	-	1
23	D321C	Casing, front, brake cable	-	1
24	D321W	Wire, front brake, cable	-	1
25	D103	Ferrule, casing	2	2
26	18/107	Nipple (Handlebar end)	1	-
27	D81	Nipple (Handlebar end)	-	1
28	D573	Nipple (Wheel end)	1	1
29	D279	Adjuster, cable	1	1
30	F879	Nut, adjuster lock	1	1
31	D280	Clevis, brake wire	1	1
32	D281	Pin, clevis	1	1
33	$\frac{1}{16}$ in \times $\frac{1}{2}$ in.	Split pin, clevis pin	1	1

CONTROL CABLES – GROUP 18
HANDLEBAR (U.S.A.) – GROUP 19

REF. No.	PART No.	DESCRIPTION	QUANTITY	
			T20	T20C
THROTTLE CABLE				
1	D316	Throttle cable	1	-
2	D316C	Casing, throttle cable	1	-
3	D316W	Wire, throttle cable	1	-
4	D317	Throttle cable	-	1
5	D317C	Casing, throttle cable	-	1
6	D317W	Wire, throttle cable	-	1
7	I2/083	Ferrule, casing	1	1
8	D285	Nipple (Twistgrip)	1	1
9	I482/050	Nipple (Carburetter)	1	1

CLUTCH CABLE				
10	D331	Clutch cable	1	-
11	D331C	Casing, clutch cable	1	-
12	D331W	Wire, clutch cable	1	-
13	D332	Clutch cable	-	1
14	D332C	Casing, clutch cable	-	1
15	D332W	Wire, clutch cable	-	1
16	D103	Ferrule, casing	2	2
17	I8/706	Nipple (Handlebar)	1	-
18	D81	Nipple (Handlebar)	-	1
19	D334	Nipple (Clutch)	1	1
20	D319	Adjuster cable	1	1
21	D268	Locknut, adjuster	1	1
22	D288	Abutment (Handlebar)	1	1
23	D333	Abutment (Clutch)	1	1

HANDLEBAR (U.S.A.) – GROUP 19

HANDLEBAR				
24	H933	Handlebar c/w control lever and Twistgrip	1	1
25	H934	Handlebar bend only	1	1
26	I6/069	Grip, handlebar rubber	1	1
CONTROL LEVERS				
27	I8/557	Lever assembly, clutch control	1	1
28	I8/556	Lever assembly, front brake control	1	1
29	I8/528	Lever only, clutch and brake	2	2
30	I8/234	Bracket, lever fulcrum	2	2

GROUP 19 – HANDLEBAR (U.S.A.)
GROUP 20 – NACELLE GEAR INDICATOR

REF. No.	PART No.	DESCRIPTION	QUANTITY	
			T20	T20C
1	12/040	Clamp, lever bracket	2	2
2	11/014	Screw, lever bracket to clamp	4	4
3	18/087	Screw, lever fulcrum pin	2	2
4	18/053	Nut, lever fulcrum pin	2	2

TWISTGRIP and CONTROL CABLES for U.S.A. Handlebars are exactly as specified for standard T20C.

NACELLE GEAR INDICATOR – GROUP 20

NACELLE GEAR INDICATOR

5	H1020	Rack and pinion assembly	1	1
6	H689	Screw, rack and pinion to nacelle $\frac{1}{4}$ in. U.H....	2	2
7	H937	Spindle assembly	1	1
8	H939	Finger, Indicator	1	1
9	H688	Screw, finger to spindle $\frac{1}{16}$ in. U.H.	1	1
10	H921	Plate, gear indicator	1	1

GEAR INDICATOR CABLE

11	D282	Cable assembly, gear indicator	1	1
12	D282C	Casing, gear indicator cable	1	1
13	D282W	Wire, gear indicator cable	1	1
14	12/083	Ferrule, gear indicator casing	2	2
15	D285	Nipple, gear indicator cable (Engine end)	1	1
16	18/115	Nipple, gear indicator casing (Indicator end)	2	2
17	E3280	Abutment gear indicator cable c/case... ..	1	1
18	H1019	Spring, gear indicator cable	1	1
19	D284	Adjuster, gear indicator cable	1	1
20	H745	Locknut, gear indicator cable adjuster	1	1

PROPRIETARY FITTINGS

Ancillary equipment which is fitted to our motor cycles is of the highest quality and is guaranteed by the manufacturers and not by ourselves. Any repairs or claims should be sent to the actual maker, or one of their accredited agents who will always give owners every possible assistance. The following are the addresses of the various manufacturers.

CARBURETTERS	Messrs. Amal Ltd., Holdford Road, Witton, Birmingham, 6.
CHAINS	Renold Chain, Ltd., Wythenshawe Manchester.
ELECTRICAL EQUIPMENT	Messrs. J. Lucas, Ltd., Great Hampton Street, Birmingham, 18.
HORN	Messrs. Clear Hooters Ltd., Hampton Street, Birmingham, 19.
SPARKING PLUGS	Champion Sparking Plugs Ltd., Feltham, Middlesex.
	K.L.G. Sparking Plugs Ltd., Cricklewood Works, London, N.W.2.
	Lodge Plugs Ltd., Rugby, Warwickshire.
SPEEDOMETERS	Messrs. Smiths Motor Accessories Ltd., Cricklewood Works, London, N.W.2.
SUSPENSION UNITS (Service)	Girling Ltd., Kings Road, Tyseley, Birmingham, 11.
(Guarantee claims only)	Triumph Engineering Co. Ltd., Meriden Works, Allesley, Coventry.

GROUP 21 – LUCAS ELECTRICAL EQUIPMENT

REF. No. PART No. DESCRIPTION QUANTITY

LUCAS ELECTRICAL EQUIPMENT – GROUP 21

ALTERNATOR (RM13)

T20 T20C

1	047518	Alternator assembly	1	1
2	466124	Rotor	1	1
3	468678	Stator complete	1	1
4	862898	Cable, stator output	1	1
5	E3475	Grommet, alternator cable	1	1
6	E3204	Screw, stator to chaincase, 1 in. U.H.	5	5
7	E1612	Washer, shakeproof	5	5
8	E1580	Key, rotor to shaft	1	1
9	465909	Nut, rotor to shaft	1	1
10	465910	Washer, rotor nut	1	1

RECTIFIER

11	47111A	Rectifier	1	1
12	F3600	Nut, to frame	1	1

IGNITION COIL (MA6)

13	45077A	Coil	1	1
14	DS57	Bolt, to bracket	2	2
15	E1612	Washer, shakeproof	2	2
16	F879	Nut, coil bolt	2	2
17	422567	Grommet, H.T. Cable	1	1
18	421863	Clip, H.T. cable	1	1
19	236741	Sleeve, L.T. cable	2	2

DISTRIBUTOR (15DI)

20	40529A	Distributor	1	1
21	406105	Clamping plate assembly	1	1
22	421106	Contact set	1	1
23	421327	Condenser	1	1
24	423759	Cam	1	1
25	421407	Spring set, auto advance	1	1
26	421056S	Weight set, auto advance	1	1
27	421054	Shaft and action plate	1	1
28	419645	Sundry parts set	1	1
29	DS57	Bolt, plate to crankcase $\frac{7}{16}$ in. U.H.	1	1
30	S25-13	Washer, plain	1	1
31	E3309	Sealing ring, distributor	1	1

BATTERY (PUZ5E/11)

32	408200	Battery	1	1
----	--------	---------	-----	-----	-----	-----	-----	-----	---	---

LUCAS ELECTRICAL EQUIPMENT — GROUP 21

REF. No.	PART No.	DESCRIPTION	QUANTITY	
			T20	T20C
HEADLAMP (MCF 575)				
1	51519A	Headlamp assembly	1	1
2	516723	Rim, headlamp	1	1
3	500291	Wire, light unit fixing	4	4
4	516728	Light unit	1	1
5	554946	Adaptor assembly	1	1
6	554710	Bulbholder, pilot	1	1
7	553780	Interior, pilot	1	1
8	312	Bulb, main 30/24W	1	1
9	988	Bulb, pilot 3W	1	1
10	H876	Adjuster screw, headlamp	1	1
11	H745	Locknut, adjuster screw	1	1
12	H875	Spring, adjuster screw	1	1
LIGHTING AND IGNITION SWITCH (P.R.S. 8)				
13	31443E	LIGHTING AND IGNITION SWITCH	1	1
14	318323	Grommet, for key	1	1
15	318241	Key	1	1
16	319333	Screw, for knob	1	1
17	318346	Knob	1	1
18	318343	Plate, index	1	1
DIPPER SWITCH				
19	380521	Switch, dipper	1	1
TAIL LAMP (529)				
20	53256A	Lamp, tail	1	1
21	526404	Lens	1	1
22	526406	Window, number plate	1	1
23	133551	Screw, fixing lens	2	2
24	161385	Grommet, screw... ..	2	2
25	554719	Bulb holder	1	1
26	526408	Base, rubber	1	1
27	988	Bulb, 3W	1	1
28	526410	Screw, lamp to number plate	3	3
29	166103	Nut, lamp to number plate	3	3
30	188366	Washer, lamp to number plate	3	3
WIRING HARNESS				
31	838121	Harness wiring	1	1
HORN (CLEAR HOOTER)				
32	D300	Horn	1	1
33	H886	Button, horn (No. 15)	1	1
34	D314	Bracket, horn	1	1

**GROUP 22 —
AMAL CARBURETTER**

FIG. 14.
AMAL
CARBURETTER
For Index See Page 51.

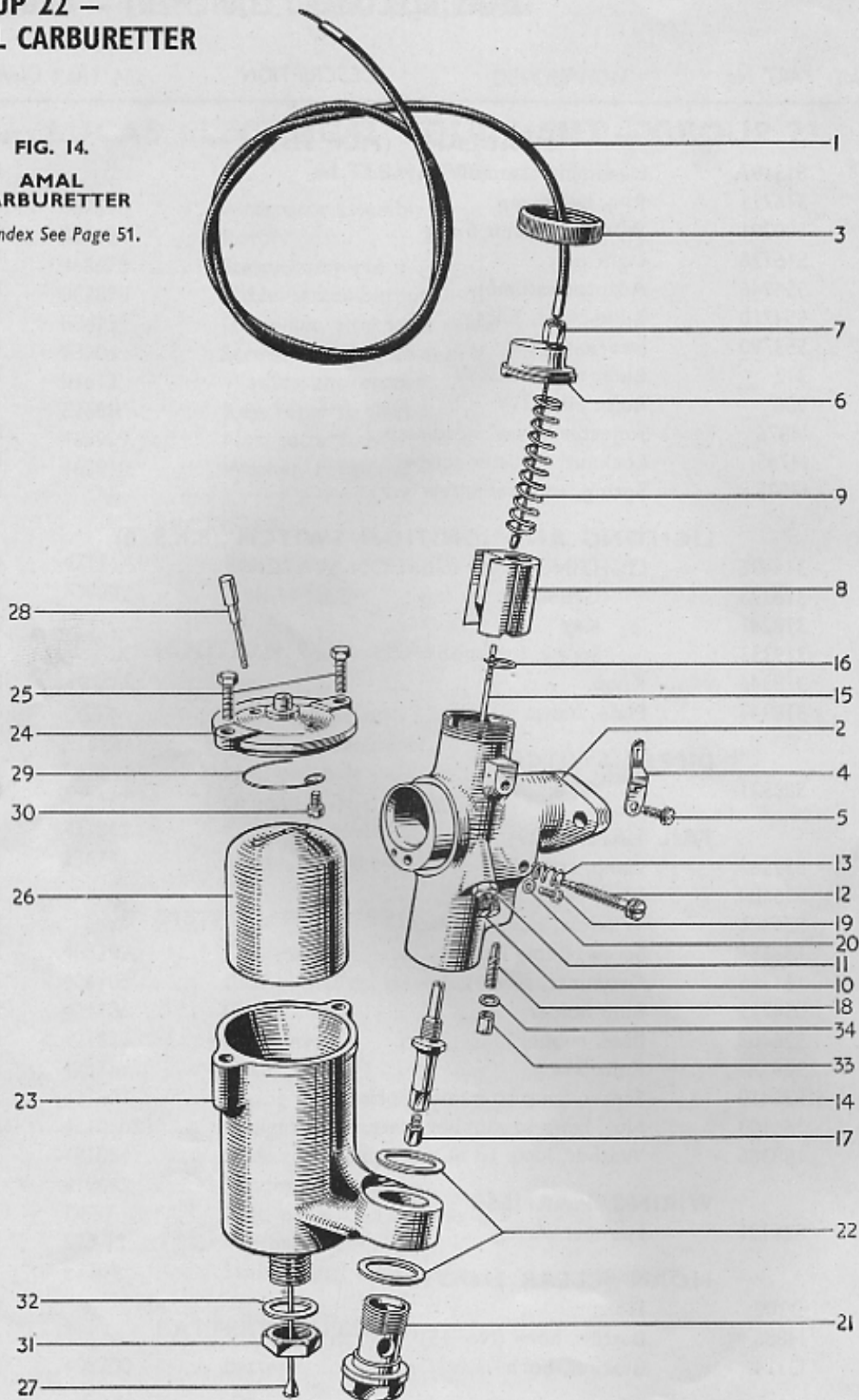

AMAL CARBURETTER — GROUP 22

REF. No.	PART No.	DESCRIPTION	QUANTITY
----------	----------	-------------	----------

AMAL CARBURETTER — GROUP 22

(See also page 61 for Zenith Carburetter)

CARBURETTER			T20	T20C
1	332/3	Carburetter, complete	1	1
MIXING CHAMBER				
2	332/001	Body, mixing chamber	1	1
3	332/012	Cap, mixing chamber	1	1
4	332/013	Spring, mixing chamber cap	1	1
5	332/014	Screw, mixing chamber cap spring and throttle locating	1	1
6	332/011	Top, mixing chamber	1	1
7	52/068	Adjuster, throttle cable... ..	1	1
8	332/005	Valve, throttle (Cutaway /4)	1	1
9	332/021	Spring, throttle valve	1	1
10	332/018	Screw, throttle adjusting	1	1
11	332/020	Nut, throttle adjusting screw	1	1
12	332/017	Screw, air adjusting	1	1
13	4/148	Spring, air adjusting screw	1	1
14	332/002	Jet for needle (0.086 in.)	1	1
15	332/003	Needle for jet	1	1
16	332/004	Clip, jet needle	1	1
17	4/042	Jet, main (size 100)	1	1
18	376/076	Jet, pilot (size 20)	1	1
19	332/026	Nut, pilot jet cover	1	1
20	116/162	Washer, cover nut	1	1

INDEX TO FIG. 14. PAGE 50.

Illust. No.	Part No.	Page No.	Ref. No.	Illust. No.	Part No.	Page No.	Ref. No.
1	D316	45	1	18	376/076	51	18
2	332/001	51	2	19	333/016	52	1
3	332/012	51	3	20	14/189	52	2
4	332/013	51	4	21	4/043	52	3
5	332/014	51	5	22	4/053	52	4
6	332/011	51	6	23	62/214	52	6
7	52/068	51	7	24	62/212	52	7
8	332/005	51	8	25	62/204	52	8
9	332/021	51	9	26	22/016	52	9
10	332/018	51	10	27	22/013	52	10
11	332/020	51	11	28	62/207	52	11
12	323/017	51	12	29	352/208	52	12
13	4/148	51	13	30	352/207	52	13
14	332/002	51	14	31	14/178	52	14
15	332/003	51	15	32	14/175	52	15
16	332/004	51	16	33	332/026	51	19
17	4/042	51	17	34	116/162	51	20

GROUP 22 — AMAL CARBURETTER**GROUP 23 — SPEEDOMETER****GROUP 24 — SPARKING PLUG**

REF. No.	PART No.	DESCRIPTION	QUANTITY	
			T20	T20C
1	333/016	Screw, mixing chamber plug	1	1
2	14/189	Washer, plug screw	1	1
3	4/043	Bolt, holding	1	1
4	4/053	Washer, holding bolt	2	2
FLOAT CHAMBER				
5	3EB	Float chamber complete	1	1
6	62/214	Body, float chamber	1	1
7	62/212	Cover, float chamber complete	1	1
8	62/204	Screws, float chamber cover	2	2
9	22/016	Float	1	1
10	22/013	Needle, float	1	1
11	62/207	Tickler	1	1
12	352/208	Spring, tickler	1	1
13	352/207	Screw, tickler spring fixing	1	1
14	14/178	Locknut, seating	1	1
15	14/175	Washer, seating locknut	1	1
CARBURETTER FIXINGS (TRIUMPH)				
16	E3254	Block, insulating carb. to head	1	1
17	E3250	Joint washer, carb. to head	2	2
18	F879	Nut, carburetter flange	2	2
19	S25-13	Washer, carburetter flange nuts	2	2
SPEEDOMETER — GROUP 23				
20	80421/36/2	Speedometer, 80 m.p.h.—Non-Trip	1	—
21	80421/55/2	Speedometer, 80 m.p.h.—Non-Trip	—	1
22	80421/37/2	Speedometer, 140 k.p.h.—Non-Trip	A	—
23	31/4/2/1	Fixing strap, speedometer	1	1
24	31/1/7	Nut, fixing strap	1	1
25	D356	Cable, speedometer drive 58 ins. (53395)	1	1
26	D356C	Casing, speedometer drive (53398)	1	1
27	D356W	Wire, speedometer drive (52108/1)	1	1
28	D175	Gearbox, speedometer drive (52283/64/3)	1	1
29	F3098	Clip, speedometer cable	1	1
SPARKING PLUG — GROUP 24				
30	HN	Plug, sparking (Lodge)	1	1
31	F80	Plug (single point) sparking (K.L.G.)	1	1
32	L10S	Plug, sparking (Champion)	1	1
33	D297	Cover, sparking plug	1	1

TWINSEAT – GROUP 25
CHAINS – GROUP 26
GIRLING SUSPENSION UNIT – GROUP 27

REF. No. PART No. DESCRIPTION QUANTITY

TWINSEAT – GROUP 25

				T20 T20C
1	F4098	Twinseat, c/w attachments	1 -
2	F4272	Twinseat, c/w attachments	- 1
SPECIAL NOTE. Seat less rear bracket interchangeable :				
3	E667A	Bolt, front bracket to frame, 1½ ins. U.H.	1 1
4	S25-3	Washer, plain	1 1
5	SI-51	Nut, front bolt	1 1
6	F4105	Bracket, rear	1 -
7	F4261	Bracket, rear	- 1
8	E1612	Washer, shakeproof	2 2
9	F879	Nut, bracket, to pan	2 2
10	F4361	Safety strap twinseat	A A
11	F4129	Screw, strap to seat, ½ in. U.H.	4 4
12	GS299	Washer, shakeproof	4 4
13	H745	Nut, strap screw...	4 4

CHAINS – GROUP 26

14	D338	Chain, primary 110044, ½ in. × ⅜ in. × 48 links	1 1
15	D341	Chain, rear 11044, ½ in. × ⅜ in × 116 links	1 1
SPECIAL NOTE. Subsequent to Engine No. 35847 use :				
16	D382	Chain, primary 114038, ⅜ in. × ⅜ in. Duplex × 62 links	1 1
17	D277	Chain, rear 110044, ½ in. × ⅜ in. × 112 links	1 1

GIRLING SUSPENSION UNIT – GROUP 27

18	SC2.6/209	Suspension unit, complete	2 -
19	SC3/204	Suspension unit, complete	- 2
20	9054/316A	Bonded bush, top	2 2
21	9054/316J	Bonded bush, bottom	2 2
22	F1760	Bolt, unit top, 1⅛ in. U.H.	2 2
23	S25-2	Washer, unit top and bottom	4 4
24	PO172A	Nut, unit top and bottom	4 4
25	F4311	Bracket, unit bottom	- 2
26	H622	Bolt, bracket, 1⅛ in. U.H.	- 2
27	F3207	Spacer, bracket bolt	- 2
28	E1330C	Washer, plain	- 2
29	SI-51	Nut, bracket bolt	- 2

GUARANTEE

WE give the following guarantee with our motorcycles, motorcycle combinations and sidecars, including all accessories and component parts other than tyres, saddles, chains and lighting and electrical equipment, and other than accessories and component parts supplied to the order of the Purchaser and differing from those comprised in the standard specifications supplied with our motorcycles, motorcycle combinations and sidecars, but including accessories and parts supplied by way of exchange as hereinafter provided. This guarantee is given in place of any implied conditions or warranties or any liabilities whatsoever statutory or otherwise; no guarantee except that hereinafter contained and no conditions or warranty whatsoever statutory or otherwise is given or is to be implied, nor are we to be under any liability whatsoever except under the guarantee hereinafter contained. Any statement, description, condition or representation contained in any catalogue, advertisement, leaflet or other publication shall not be construed as enlarging, varying or overriding anything herein contained. In the case of machines (a) which have been used for "hiring out" purposes or (b) any motorcycle and/or sidecar used for any dirt track, cinder track or grass track racing or competitions (or any competition of any kind within an enclosure for which a charge is made for admission to take part in or view the competition) or (c) machines from which the trade mark, name or manufacturing number has been altered or removed or (d) any machines in which parts have been used not supplied by or approved by the motorcycle manufacturer or (e) any machine from which the silencing system as fitted by the manufacturer has been partially or wholly removed or interfered with, no guarantee, condition or warranty of any kind statutory or otherwise, is given or is to be implied, nor are we to be under any liability whatsoever in respect of any such machine. We guarantee, subject to the conditions mentioned below, that all precautions which are usual and reasonable have been taken by us to secure excellence of materials and workmanship but this guarantee is to extend and be in force for six months only in U.K. and ninety days overseas from date of purchase, or date of exchange in case of any accessory or part supplied by way of exchange as hereinafter provided, and damages for which we make ourselves responsible under this guarantee are limited to the free repair of or supply of a new part or accessory in exchange for the part of the motorcycle, motorcycle combination or sidecar or accessory which may have proved defective. We undertake, subject to the conditions mentioned below, to make good in manner aforesaid any part or accessory covered by this guarantee which has proved defective within the said period. We do not undertake to replace or refix or bear the cost of replacing or refixing any such new part or accessory in the motorcycle, motorcycle combination or sidecar. As motorcycles, motorcycle combinations and sidecars are easily liable to derangement by neglect or misuse, this guarantee does not apply to defects caused by wear and tear, misuse or neglect. The term "misuse" shall include, amongst others, the following acts: 1. The attaching of a sidecar to a motorcycle in such a manner as to cause damage or calculated to render the latter unsafe when ridden. 2. The use of a motorcycle or of a motorcycle and sidecar combined, when carrying more persons or a greater weight than that for which the machine was designed by the manufacturers. 3. The attaching of a sidecar to a motorcycle by any form of attachment not provided, supplied or approved by the manufacturers, or to a motorcycle which is not designed for such use. We do not guarantee tyres, saddles, chains or lighting and electrical equipment, or any accessories or component parts supplied to the order of the Purchaser differing from those comprised in the standard specifications supplied with our motorcycle combinations or sidecars. As regards all such tyres, saddles, chains, lighting and electrical equipment, accessories and component parts, no guarantee, condition or warranty of any kind statutory or otherwise is given or is to be implied, and we are to be under no liability whatsoever in respect thereof.

CONDITIONS OF GUARANTEE

If a defective part or accessory should be found in our motorcycles, motorcycle combinations or sidecars, or in any part or accessory supplied by way of exchange as before provided, it must be sent to us CARRIAGE PAID and accompanied by an intimation from the owner that he desires to have it repaired or exchanged free of charge under our guarantee, and he must also furnish us at the same time with the frame number of the machine, the date of purchase or the date when the alleged defective part or accessory was exchanged as the case may be. Falling compliance with the above, such articles will lie here at THE RISK OF THE OWNER, and this guarantee and any implied guarantee, warranty or condition shall not be enforceable.

REPAIRS

Any motorcycle, motorcycle combination or sidecar sent to us to be plated, enamelled or repaired will be repaired upon the following conditions, *i.e.*, we guarantee that all precautions which are usual and reasonable have been taken by us to secure excellence of materials and workmanship, such guarantee to extend and be in force for three months only from the time such work shall have been executed, and this guarantee is in lieu and in exclusion of all conditions and warranties statutory or otherwise, and all liabilities whatsoever and the damages recoverable are limited to the cost of any further work which may be necessary to amend and make good the work found to be defective.

NOTE

We do not appoint agents for the sale on our behalf of our motorcycles or other goods, but we assign to motorcycle Dealers areas in which we supply to such Dealers exclusively for re-sale in such areas. No such Dealer is authorised to transact any business, give any warranty, make any representation or incur any liability on our behalf. Published retail prices are for delivery free of charge at Dealers' premises. All goods are offered for sale subject to the price ruling at time of delivery. We reserve the right to modify or deviate from the published specification.

TRIUMPH SERVICE

There are Triumph distributors and dealers in all parts of the world who carry adequate stocks of Triumph parts and who are ready at all times to help and advise owners of Triumph motorcycles.

INDEX

	Page No.
Group 1—CARTON PACKS	5
Group 2—ENGINE	6
Crankcase... .. .	8
Crankcase bearings (engine)	8
Crankcase filter	9
Cylinder barrel	6
Cylinder head	6
Engine sprocket	9
Flywheels and connecting rod	7
Gasket set	12
Inner cover, left side	9
Inner cover, right side	12
Oil pumps	8
Overhead rocker and covers	6
Outer cover, left side	9
Outer cover, right side	12
Piston	6
Push rods and cover	7
Rocker oil pipe	7
Tappets	7
Timing gears and camshaft	8
Valves, guides and springs	7
Group 3—GEARBOX AND CLUTCH	13
Camplate	13
Clutch	15
Clutch control	16
Filler, level and drain plugs	15
Gearbox casing bearings	14
Gearbox sprocket	15
Gearbox change mechanism	13
Kickstarter	15
Selector forks and spindle	13
Shafts and gears	13
Group 4—EXHAUST SYSTEM	18
Group 5—FRAME	18

	Page No.
Crankcase shield... ..	19
Pillion footrest brackets	19
Swinging fork	19
Group 6—STAND	19
Group 7—TELESCOPIC FRONT FORK	26
Steering races	27
Group 8—WHEELS	29
Front wheel	29
Front wheel brake	29
Rear wheel	31
Rear wheel brake	32
Rear wheel chain adjuster	32
Group 9—MUDGUARDS	33
Front mudguard	33
Licence holder	33
Rear mudguard	33
Group 10—NUMBER PLATES	35
Group 11—REAR CHAINGUARD	36
Group 12—TOOLBOX, BATTERY, CARRIER AND AIR CLEANER	36
Group 13—TOOLS	37
Group 14—PETROL AND OIL TANKS	39
Group 16—REAR BRAKE PEDAL	42
Group 17—HANDLEBAR	42
Control levers	42
Twistgrip	44

Group 18—CONTROL CABLES	44
Clutch cable	45
Front brake cable	44
Throttle cable	45
Group 19—HANDLEBAR (U.S.A.)...	45
Group 20—NACELLE GEAR INDICATOR	46

PROPRIETARY FITTINGS

Group 21—LUCAS ELECTRICAL EQUIPMENT	48
Alternator	48
Battery	48
Dipper switch	49
Distributor	48
Headlamp	49
Horn	49
Ignition Coil	48
Lighting and ignition switch	49
Rectifier	48
Tail lamp	49
Wiring harness	49
Group 22—AMAL CARBURETTER	51
Group 23—SPEEDOMETER	52
Group 24—SPARKING PLUG	52
Group 25—TWINSEAT	53
Group 26—CHAINS	53
GROUP 27—GIRLING SUSPENSION UNITS	53

INDEX TO ILLUSTRATIONS

		Page No.
Fig. 1.	Engine and gearbox unit	10
„ 2.	Mainshaft and layshaft gears	14
„ 3.	Clutch and shock absorber unit... ..	17
„ 4.	Frame and components	20
„ 5.	Telescopic front fork	22
„ 6.	Telescopic front fork T20C	24
„ 7.	Front wheel	28
„ 8.	Rear wheel... ..	30
„ 9.	Mudguard, number plates and rear chainguard	34
„ 10.	Toolbox, battery carrier and air cleaner	37
„ 11.	Tools	38
„ 12.	Petrol and oil tanks	40
„ 13.	Handlebar and components	43
„ 14.	Amal carburetter	50
„ 15.	Zenith Carburetter	63

To assist the owner and dealer in identifying requirements, this book contains numerous exploded views of the major assemblies. Each component part on the illustration is numbered, and by cross reference to the appropriate index, the part number of the component will be found. Against each part number a page and reference number is shown and by referring to the appropriate page, the full description of the part will be found against the reference number.

EXAMPLE.

To find the part number of the cylinder head gasket :

1. Refer to the illustration index above, where it will be found that the engine is illustrated on page 10.
2. Note that the number of the gasket in the illustration is 9.
3. Refer to the index on page 11.
4. Note that illustration number 9 is part number E3217 listed on page 6, line 11.

*Tournez s'il vous plait.
Véase al dorso.
Bitte wenden.*

MANIÈRE D'IDENTIFIER LA PIÈCE DE RECHANGE REQUISE

Afin d'assister MM. les marchands et MM. les possesseurs à l'identification des pièces de rechange, ce livre contient de nombreuses illustrations des montages principaux en façon de "perspectives éclatées".

Chaque pièce composante à l'illustration est numérotée ; en se référant à l'index approprié on peut trouver le numéro relatif.

A côté de chaque pièce illustrée se trouve le numéro de la page et le numéro de référence ; en se référant à la page approprié la description complète de la pièce sera facilement constaté.

Exemple.

Pour identifier le numéro de référence du joint de culasse :

1. Se référer à la page intitulée "Index to Illustrations" où on trouvera que le moteur est illustré sur la page 10.
2. Noter qu'à côté du joint de culasse se trouve le numéro 9.
3. Se référer à l'index donné sur la page numéro 11.
4. On y constatera que suivant le numéro 9 se trouve :
 - (a) le numéro relatif—E.3217
 - (b) le numéro de la page d'index—6
 - (c) la ligne de référence—11.

MANERA DE ENCONTRAR LA PIEZA DESEADA

Para ayudar al propietario y al representante en la identificación de las piezas deseadas este libro contiene numerosas ilustraciones de los principales montajes.

Cada pieza componente en la ilustración está numerada y al referirse al índice apropiada, se encontrará el número de la pieza.

Contra el número de cada pieza se muestra el número de referencia, y al referirse a la página apropiada a descripción completa de cada pieza se encontrará contra el número de referencia.

Ejemplo.

Para encontrar el número de pieza de la empaquetadura de la culata de cilindro :

1. Referirse a la página "Index to Illustrations" donde se verá que la ilustración del motor está en la página 10.
2. Nótese que el número de la empaquetadura en la ilustración es 9.
3. Referirse al índice de la ilustración en cuestión en la página 11.
4. Notese que no. 9 es pieza número E.3217 en la lista de la página 6, línea de referencia no. 11.

ANWEISUNG ZUR IDENTIFIZIERUNG BENOETIGTER ERSATZTEILE

Dieses Buch enthält zahlreiche Zerlege-Abbildungen der Hauptzusammenstellungen, um dem Besitzer und dem Verteiler beim Identifizieren seiner Förderungen zu helfen. Jedes Teil auf der Abbildung ist mit einer Nummer versehen, und die Bestandteilnummer wird durch Nachschlagen des bezüglichen Verzeichnisses gefunden. Mit jeder Teilnummer ist die Seite und die Referenznummer gegeben, und durch Nachschlagen der bezüglichen Seite wird die vollständige Beschreibung des Teiles unter der Referenznummer gefunden.

Zum Beispiel.

Um die Nummer der Zylinderkopfdichtung zu finden :

1. Schlagen Sie das Abbildungsverzeichnis, oben, nach, wo es gefunden wird, dass die Maschine auf Seite 10 abgebildet ist.
2. Merken Sie, dass Nr. 9 ist die Nummer der Dichtung auf der Abbildung.
3. Schlagen Sie das Verzeichnis auf Seite 11, nach.
4. Merken Sie, dass die Abbildungsnummer 9 ist die Teilnummer E.3217, eingetragen auf Seite 6, Zeile 11.

ZENITH 17 MX CARBURETTER T20 AND T20C

from Engine No. 39167

NEW TRIUMPH PARTS

							T20 T20C	
1	E3957	Cylinder head assembly		
2	E3954	Adaptor, carb. to head	1	1
3	E3956	Stud, adaptor to head	2	2
4	F4470	Petrol pipe assembly	1	1
5	D406	Cable, throttle	1	1
6	D407	Nipple, carburetter	1	1
7	D411	Nipple, twistgrip	1	1
8	F4469	Rubber, air cleaner	1	1

ZENITH PARTS

9	17MXZ-CS5	Carburetter c/w throttle cable	1	1
10	017620	Body, carburetter	1	1
11	017129	Fibre washer, large	1	1
12	017130	Gauze, filter	1	1
13	017131	Bolt, union	1	1
14	017132	Fibre washer, small	1	1
15	017133	Jet, slow running (50)	1	1
16	017134	Jet main (78)	1	1
17	017621	Tube, emulsion	1	1
18	017624	Slide, throttle	1	1
19	017625	Spring, throttle slide	1	1
20	017628	Slide, starter (65)	1	1
21	017629	Top, mixing chamber	1	1
22	07087	Screw, top to body	1	1
23	017143	Adjuster, cable	1	1
24	07323	Locknut, adjuster	1	1
25	017144	Screw, throttle stop	1	1
26	017156	Spring, throttle stop screw	1	1
27	017145	Bolt, clamp	1	1
28	15321	Nut, clamp bolt	1	1
29	220630	Float	1	1
30	216472	Pin, float hinge	1	1
31	017630	Washer, joint	1	1
32	017583	Bowl, float	1	1
33	07087	Screw, float bowl	2	2
34	017570	Adaptor, intake	1	1
35	07967	Screw, adaptor	2	2
36	04692	Washer, adaptor screw	2	2
37	017729	"O" ring, carburetter to adaptor	1	1

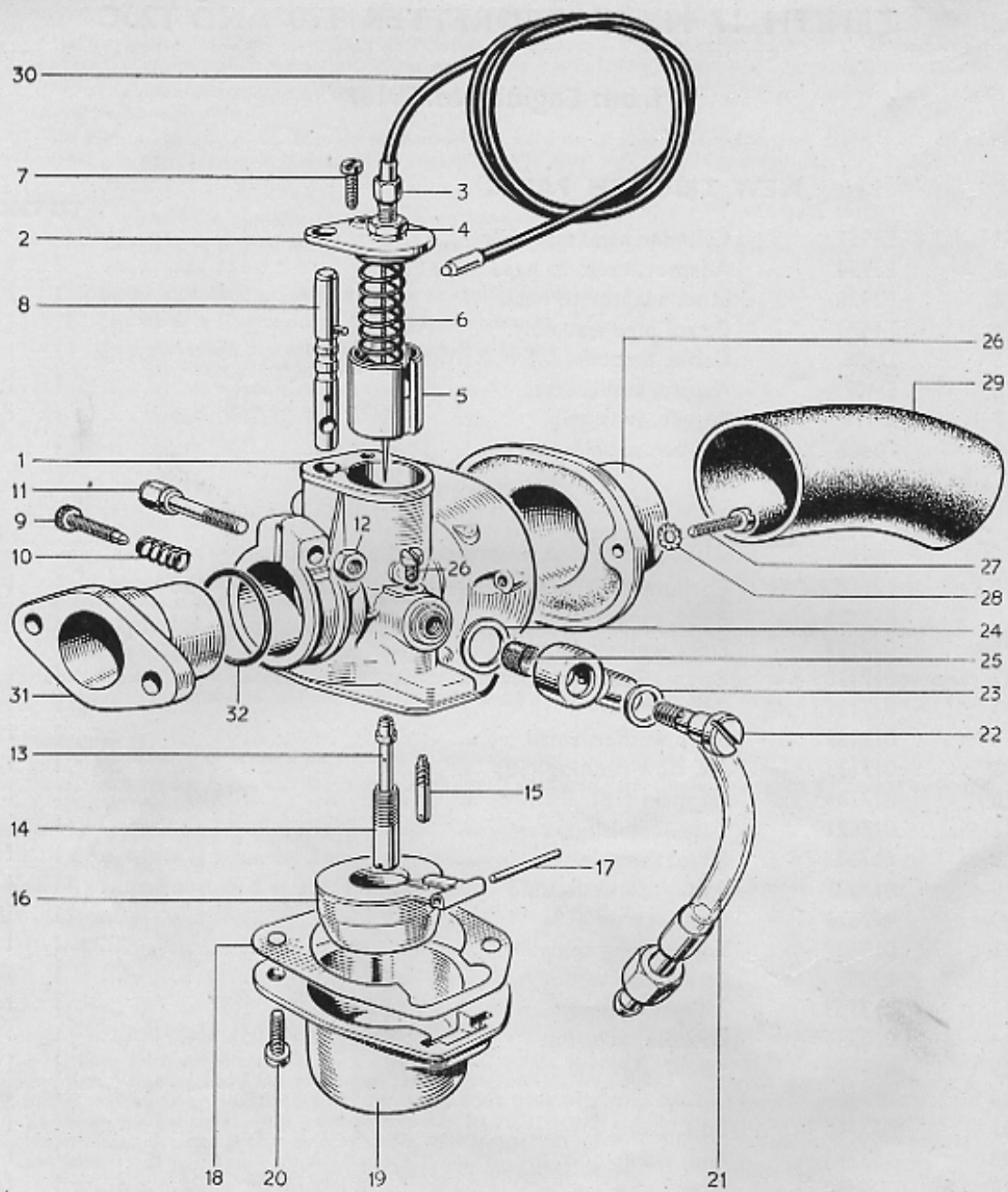

FIG. 15. ZENITH CARBURETTER

Maker's address : ZENITH CARBURETTER CO.,
 Honeypot Lane,
 Stanmore,
 Middlesex

INDEX TO FIG. 15. ZENITH CARBURETTER

<i>Illust. No.</i>	<i>Part No.</i>	<i>Page No.</i>	<i>Ref. No.</i>
1	017620	61	10
2	017629	61	21
3	017143	61	23
4	07323	61	24
5	017624	61	18
6	017625	61	19
7	07087	61	22
8	017628	61	20
9	017144	61	25
10	017156	61	26
11	017145	61	27
12	15321	61	28
13	017621	61	17
14	017134	61	16
15	017133	61	15
16	220630	61	29
17	216472	61	30
18	017630	61	31
19	017583	61	32
20	07087	61	33
21	F4470	61	4
22	017131	61	13
23	017132	61	14
24	017129	61	11
25	017130	61	12
26	017570	61	34
27	07967	61	35
28	04692	61	36
29	F4469	61	8
30	D406	61	5
31	E3954	61	2
32	017729	61	37

PETROL TANK

From Engine No. 38130 use

T20 T20C

			T20	T20C
1	F4465	Petrol tank, less fittings	1	-
2	F4466	Styling unit, L.H.	1	-
3	F4467	Styling unit, R.H.	1	-
4	F4468	Screw, styling unit	4	-

TWISTGRIP

From Engine No. 38130 use

			T20	T20C
5	366/2	Twistgrip, complete	1	1
6	366/001	Body, top half	1	1
7	366/002	Body, bottom half	1	1
8	366/004	Rotor	1	1
9	366/007	Spring, friction	1	1
10	366/008	Screw, friction spring	1	1
11	376/079	Screw, fixing	2	2
12	16/070	Grip, plastic	1	1
13	366/006	Cable stop	1	1
14	D407	Nipple, cable	1	1

DH13

POBLES THROUGH